



FDT SERIES ELEMENTS WITH LEAD ATTACHMENT

SPECIFICATIONS

- ◆ Piezo Film Technology
- ◆ Flexible Leads
- ◆ High Strain Output
- ◆ Film Thickness Options
- ◆ Lamination Options
- ◆ Solderable Connection Pins

The “F” in FDT Series stands for “Flexible Leads”. These are rectangle elements of Piezo film with silver ink screen printed electrodes. Rather than making the lead attachment near the sensor, the Piezo polymer tail extends from the active sensor area as flex circuit material with offset traces. This gives a very flat, flexible lead with a connector at the end.

The FDT elements are available in a variety of different sizes and thicknesses. They are available without a laminate (FDT), with a laminated (0.005” mylar) on one side (FLDT) or with tape release layer adhesive (FDT with adh) in the sensor area.

FEATURES

- ◆ Thin piezo film sensor
- ◆ Flexible leads give flat profile to the sensor
- ◆ Dynamic strain sensing with a high output
- ◆ Typical interface to a 1 or 10 M Ω input impedance
- ◆ Output Voltage (dependent on force applied) 10 mV to 100V

APPLICATIONS

- ◆ Sensing Direct Contact Force
- ◆ Recording Time of an Event
- ◆ Counting Number of Impact Events
- ◆ Measuring Impact Related Events
- ◆ Sensing Vibration using Cantilevered Beam
- ◆ Wakeup Switch
- ◆ Motion Detection

DIMENSIONS and PART NUMBERS

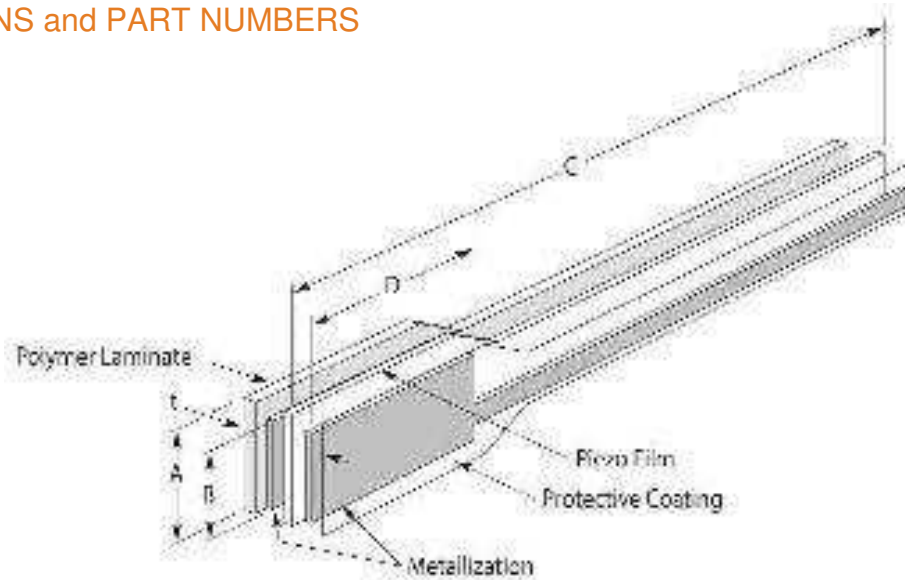

DIMENSION in INCHES (mm)

Model Number	Part Number	Film thickness	A Film	B Electrode	C Film	D Electrode	t (µm)	Cap (nF)
FDT1-028K	1-1002785-1	28 µm	.620 (16)	.485 (12)	9.25 (235)	1.16 (30)	55	1.37
FDT1-052K	2-1002785-1	52 µm	.620 (16)	.485 (12)	9.25 (235)	1.16 (30)	85	.740
FLDT1-028K	1-1002786-1	28 µm	.620 (16)	.485 (12)	9.25 (235)	1.16 (30)	205	1.37
FLDT1-052K	2-1002786-1	52 µm	.620 (16)	.485 (12)	9.25 (235)	1.16 (30)	230	.740
FDT1-028K w/adh-F	1001777	28 µm	.650 (17)	.485 (12)	5.51 (140)	1.18 (30)	125	1.37

The connector pins on the FDT sensors can be directly soldered to a PCB with a reasonable level of care. This component cannot withstand high temperatures (>80°C) and therefore soldering of the pins to a PCB must be done quickly. A heat sink clamped to the interface area between the film and the crimps will take the heat away from the film. Pre-tin the pins and then quickly solder them to the board. Do not allow the soldering iron to touch the film and do not use a dwell time of more than 5 seconds on the pins. Low temperature solder can also be used.

NORTH AMERICA

Measurement Specialties, Inc.,
a TE Connectivity Company
Tel: +1-800-522-6752
Email: customercare.dtm@te.com

EUROPE

MEAS Deutschland GmbH
a TE Connectivity Company
Tel: +49-800-440-5100
Email: customercare.dtm@te.com

ASIA

Measurement Specialties (China), Ltd.,
a TE Connectivity Company
Tel: +86 0400-820-6015
Email: customercare.chdu@te.com

TE.com/sensorsolutions

Measurement Specialties, Inc., a TE Connectivity company.

Measurement Specialties, TE Connectivity, TE Connectivity (logo) and EVERY CONNECTION COUNTS are trademarks. All other logos, products and/or company names referred to herein might be trademarks of their respective owners.

The information given herein, including drawings, illustrations and schematics which are intended for illustration purposes only, is believed to be reliable. However, TE Connectivity makes no warranties as to its accuracy or completeness and disclaims any liability in connection with its use. TE Connectivity's obligations shall only be as set forth in TE Connectivity's Standard Terms and Conditions of Sale for this product and in no case will TE Connectivity be liable for any incidental, indirect or consequential damages arising out of the sale, resale, use or misuse of the product. Users of TE Connectivity products should make their own evaluation to determine the suitability of each such product for the specific application.

© 2015 TE Connectivity Ltd. family of companies All Rights Reserved.

Данный компонент на территории Российской Федерации

Вы можете приобрести в компании MosChip.

Для оперативного оформления запроса Вам необходимо перейти по данной ссылке:

<http://moschip.ru/get-element>

Вы можете разместить у нас заказ для любого Вашего проекта, будь то серийное производство или разработка единичного прибора.

В нашем ассортименте представлены ведущие мировые производители активных и пассивных электронных компонентов.

Нашей специализацией является поставка электронной компонентной базы двойного назначения, продукции таких производителей как XILINX, Intel (ex.ALTERA), Vicor, Microchip, Texas Instruments, Analog Devices, Mini-Circuits, Amphenol, Glenair.

Сотрудничество с глобальными дистрибьюторами электронных компонентов, предоставляет возможность заказывать и получать с международных складов практически любой перечень компонентов в оптимальные для Вас сроки.

На всех этапах разработки и производства наши партнеры могут получить квалифицированную поддержку опытных инженеров.

Система менеджмента качества компании отвечает требованиям в соответствии с ГОСТ Р ИСО 9001, ГОСТ РВ 0015-002 и ЭС РД 009

Офис по работе с юридическими лицами:

105318, г.Москва, ул.Щербаковская д.3, офис 1107, 1118, ДЦ «Щербаковский»

Телефон: +7 495 668-12-70 (многоканальный)

Факс: +7 495 668-12-70 (доб.304)

E-mail: info@moschip.ru

Skype отдела продаж:

moschip.ru

moschip.ru_4

moschip.ru_6

moschip.ru_9