

S1D13719 Mobile Graphics Engine

February 2012

The S1D13719 is a Mobile Graphics Engine solution designed with support for the digital video revolution in mobile products. The S1D13719 contains an integrated dual port camera interface, hardware JPEG encoder/decoder and can be interfaced to an external MPEG codec. Seamlessly connecting to both direct and indirect CPU interfaces, it provides support for up to two LCD panels. The Mobile Graphics Engine supports all standard TFT panel types and many extended TFT types, eliminating the need for an external timing control IC. The S1D13719, with its 512K bytes of embedded SRAM and rich feature set, provides a low cost, low power, single chip solution to meet the demands of embedded markets requiring Digital Video, such as Mobile Communications devices and Palm-size PDAs.

Additionally, products requiring a rotated display can take advantage of the SwivelView™ feature which provides hardware rotation of the display memory transparent to the software application. The S1D13719 also provides support for “Picture-in-Picture Plus” (a variable size window with overlay functions). Higher performance is provided by the Hardware Acceleration Engine which provides 2D BitBLT functions.

The S1D13719 provides impressive support for cellular and other mobile solutions requiring Digital Video support. However, its impartiality to CPU type or operating system makes it an ideal display solution for a wide variety of applications.

■ FEATURES

- Embedded 512K byte SRAM Display Buffer
- Low Operating Voltage
- Direct and Indirect CPU interfaces
- Programmable resolutions and color depths
- Support for 2 panels (LCD2 must be RAM integrated)
- Support for RGB, Serial and Parallel I/F Panels
- Extended TFT interfaces including HR-TFT
- Internal PLL or digital clock input
- SD Memory Card interface
- Dual port Camera interface
- Fractional View and Capture hardware resizer, reduction from 1x to ½x size in 128 steps
- Fractional Zoom for YUV 4:2:2, expand from 1x to 2x size in 128 steps
- Hardware JPEG encoder/decoder
- YUV to RGB converter
- SwivelView™ (90°, 180°, 270° hardware rotation of displayed image)
 - (Patent # 5,734,875 - Patent # 5,956,049 - Patent #6,262,751)
- “Picture-in-Picture Plus”
- 2D Hardware Acceleration Engine
- Software Initiated Power Save Mode



■ SYSTEM BLOCK DIAGRAM

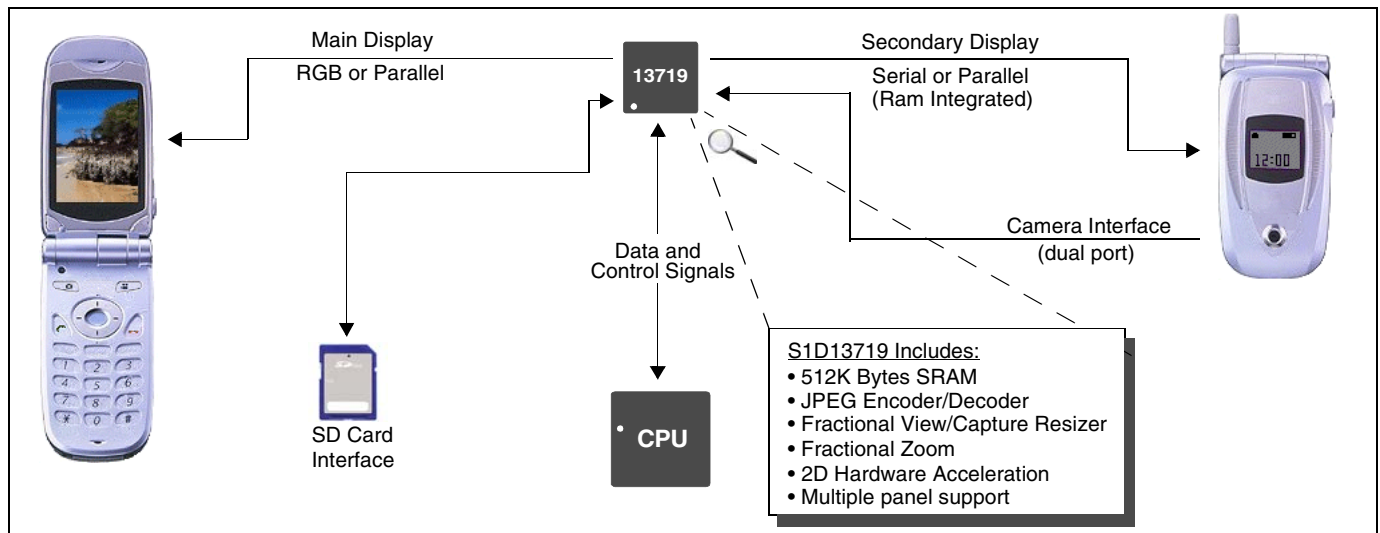

S1D13719

DESCRIPTION

Integrated Display Buffer

- 512K bytes of embedded SRAM
- Addressable as a single linear address space

CPU Interface

- 16-bit Generic Asynchronous CPU interface
- Direct and Indirect addressing

Panel Support

- Supports up to 2 LCD panels
- LCD1: 9/12/18/24-bit RGB panel
LCD2: 8/9-bit Serial Ram Integrated panel
- LCD1: 8/16/18/24-bit Parallel Ram Integrated panel
LCD2: 8/9-bit Serial Ram Integrated panel
- LCD1: 8/16/18/24-bit Parallel Ram Integrated panel
LCD2: 8/16/18/24-bit Parallel Ram Integrated panel
- LCD1: 9/12/18/24-bit RGB panel
LCD2: 8-bit Parallel Ram Integrated panel
- TFT, HR-TFT, Casio TFT, α -TFT, ND-TFD, and Extended TFT
- Typical resolution of:
up to 320x480 at 16 bpp
up to 320x240 at 32 bpp

Acceleration

- 2D BitBLT Engine
- SwivelView: 90°, 180°, 270° hardware rotation of displayed image
- Mirror Display: hardware "mirror" image of display

Display Features

- 8/16/32 bit-per-pixel (bpp) support
- Picture-in-Picture Plus: displays a variable size window overlaid over the background image
- Overlay Functions
- Pixel Doubling: doubles the effective resolution
- Video Invert: inverts display data

Digital Video

- Dual port Camera Interface (YUV 4:2:2)
- Hardware JPEG Encoder (YUV 4:2:2, 4:1:1, 4:2:0)
- Hardware JPEG Decoder (YUV 4:4:4, 4:2:2, 4:1:1, 4:2:0)
- YUV Display/Capture (YUV 4:2:2, 4:2:0)
- Memory Image JPEG Encode (YUV 4:2:2, 4:1:1, 4:2:0)
- View and Capture hardware resizer, reduction from 1x to 1/2x size in 128 steps with trimming functions
- Fractional Zoom for YUV 4:2:2, expand from 1x to 2x size in 128 steps
- YUV to RGB and RGB to YUV converters
- Support for external MPEG codec interface

Miscellaneous

- Internal PLL or digital clock input
- Software initiated power save mode
- CORE_{VDD} 1.8 volts and IO_{VDD} 3.0 volts
- PFBGA 180-pin package

CONTACT YOUR SALES REPRESENTATIVE FOR THESE COMPREHENSIVE DESIGN TOOLS

- S1D13719 Technical Documentation
- S1D13719 Evaluation Boards
- CPU Independent Software Utilities
- Royalty Free source level driver code



sybian
OS



Japan
Seiko Epson Corporation
IC International Sales Group
421-8, Hino, Hino-shi
Tokyo 191-8501, Japan
Tel: 042-587-5812
Fax: 042-587-5564
<http://www.epson.co.jp/>

Hong Kong
Epson Hong Kong Ltd.
20/F, Harbour Centre
25 Harbour Road
Wanchai, Hong Kong
Tel: 2585-4600
Fax: 2827-4346
<http://www.epson.com.hk/>

North America
Epson Electronics America, Inc.
214 Devcon Drive
San Jose, CA 95112, USA
Tel: (800) 228-3964
Fax: (408) 922-0238
<http://www.eea.epson.com/>

Europe
Epson Europe Electronics GmbH
Riesstrasse 15
80992 Munich, Germany
Tel: 089-14005-0
Fax: 089-14005-110
<http://www.epson-electronics.de/>

Taiwan
Epson Taiwan Technology & Trading Ltd.
14F, No. 7
Song Ren Road
Taipei 110
Tel: 02-8786-6688
Fax: 02-8786-6677
<http://www.epson.com.tw/>

Singapore
Epson Singapore Pte Ltd
1 HarbourFront Place #03-02
HarbourFront Tower One
Singapore, 098633
Tel: (65) 6586-5500
Fax: (65) 6271-3182
<http://www.epson.com.sg/>

© SEIKO EPSON CORPORATION 2004-2012. All rights reserved.
Information in this document is subject to change without notice. You may download and use this document, but only for your own use in evaluating Seiko Epson/EPSON products. You may not modify the document. Epson Research and Development, Inc. disclaims any representation that the contents of this document are accurate or current. The Programs/Technologies described in this document may contain material protected under U.S. and/or International Patent laws.
EPSON is a registered trademark of Seiko Epson Corporation. All other trademarks are the property of their respective owners.

Данный компонент на территории Российской Федерации

Вы можете приобрести в компании MosChip.

Для оперативного оформления запроса Вам необходимо перейти по данной ссылке:

<http://moschip.ru/get-element>

Вы можете разместить у нас заказ для любого Вашего проекта, будь то серийное производство или разработка единичного прибора.

В нашем ассортименте представлены ведущие мировые производители активных и пассивных электронных компонентов.

Нашей специализацией является поставка электронной компонентной базы двойного назначения, продукции таких производителей как XILINX, Intel (ex.ALTERA), Vicor, Microchip, Texas Instruments, Analog Devices, Mini-Circuits, Amphenol, Glenair.

Сотрудничество с глобальными дистрибьюторами электронных компонентов, предоставляет возможность заказывать и получать с международных складов практически любой перечень компонентов в оптимальные для Вас сроки.

На всех этапах разработки и производства наши партнеры могут получить квалифицированную поддержку опытных инженеров.

Система менеджмента качества компании отвечает требованиям в соответствии с ГОСТ Р ИСО 9001, ГОСТ РВ 0015-002 и ЭС РД 009

Офис по работе с юридическими лицами:

105318, г.Москва, ул.Щербаковская д.3, офис 1107, 1118, ДЦ «Щербаковский»

Телефон: +7 495 668-12-70 (многоканальный)

Факс: +7 495 668-12-70 (доб.304)

E-mail: info@moschip.ru

Skype отдела продаж:

moschip.ru

moschip.ru_4

moschip.ru_6

moschip.ru_9