



SECTION A-A
SCALE 4:1



SECTION B-B
SCALE 4:1

spec ref	-	dr	Wei-Long Zhang	2012/07/05	projection	MM	size	A2	scale	1:1
tolerance std	ISO 406 ISO 1101	eng	Sunny2 Liu	2016/05/05			ecn no	ELX-DG-24036-1	rel level	Released
TOLERANCES UNLESS OTHERWISE SPECIFIED		chr	Terris Liu	2016/05/20						
surface	linear	0.X	±0.3		STD VERT REC UNIVERSAL HIGH POWER CARD EDGE	dwg no 10121506	rev C	Product - Customer Drw		
	angular	0°	±2°					cat. no.	sheet 1 of 4	

CONTACT TYPE	TOP LAYER DESCRIPTION	TABLE 1 (HPCE / SOLDER TAILS) PLATED THROUGH-HOLE REQUIREMENTS				
		DRILLED HOLE DIAMETER	COPPER THICKNESS	TIN-LEAD THICKNESS	TIN THICKNESS	FINISHED HOLE DIAMETER
POWER & SIGNAL	TIN-LEAD	1.10-1.16 (1.15 DRILL)	0.025 - 0.050	0.005 - 0.015	--	0.94 - 1.10
	IMMERSION TIN	1.10-1.16 (1.15 DRILL)	0.025 - 0.050	--	0.9 - 1.5um	0.94 - 1.10
	COPPER (SEE NOTE 8)	1.10-1.16 (1.15 DRILL)	0.025 - 0.050	--	--	0.94 - 1.10

CONTACT TYPE	TOP LAYER DESCRIPTION	TABLE 2 (HPCE / PRESS-FIT TAILS) PLATED THROUGH-HOLE REQUIREMENTS				
		DRILLED HOLE DIAMETER	COPPER THICKNESS	TIN-LEAD THICKNESS	TIN THICKNESS	FINISHED HOLE DIAMETER
POWER & SIGNAL	TIN-LEAD	0.81-0.86 (0.85 DRILL)	0.025 - 0.050	0.005 - 0.015	--	0.65 - 0.80
	IMMERSION TIN	0.81-0.86 (0.85 DRILL)	0.025 - 0.050	--	0.9 - 1.5um	0.70 - 0.80
	COPPER (SEE NOTE 8)	0.81-0.86 (0.85 DRILL)	0.025 - 0.050	--	--	0.70 - 0.80



Amphenol FCI

© 2016 AFCI

spec ref	-	dr	Wei-Long Zhang	2012/07/05	projection	MM	size	A2	scale	1:1
tolerance std	ISO 406 ISO 1101	eng	Sunny2 Liu	2016/05/05			ecn no	ELX-DG-24036-1	rel level	Released
TOLERANCES UNLESS OTHERWISE SPECIFIED		chr	Teris Liu	2016/05/20						
		appr	Pai-Ming Zheng	2016/05/24						
surface	linear	0.X	±0.3	Amphenol FCI	title STD VERT REC UNIVERSAL HIGH POWER CARD EDGE	cat. no. Product - Customer Drw	dwg no 10121506	rev C	sheet 2 of 4	
		0.XX	±0.10							
	angular	0°	±2°							

PDS: Rev :C

STATUS:Released

Printed: May 24, 2016

A

B

C

D

E

F

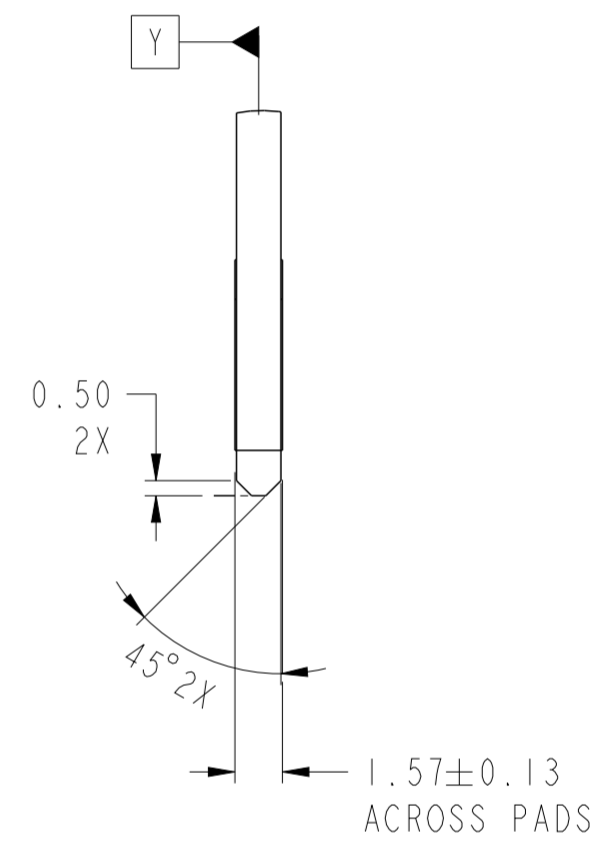

Amphenol FCI

© 2016 AFCl

spec ref	-	dr	Wei-Long Zhang	2012/07/05	projection	MM	size	A2	scale	1:1
tolerance std	ISO 406 ISO 1101	eng	Sunny2 Liu	2016/05/05			ecn no	ELX-DG-24036-1	rel level	Released
TOLERANCES UNLESS OTHERWISE SPECIFIED		chr	Terris Liu	2016/05/20						
		appr	Pai-Ming Zheng	2016/05/24						
surface	ISO 1302	linear	0.X	±0.3			product family	STD VERT REC UNIVERSAL	dwg no	10121506
		angular	0°	±2°			cat. no.	Product - Customer Drw	rev	C
PDS: Rev :C STATUS:Released Printed: May 24, 2016 sheet 3 of 4										

10121506 - MM NN PP LF

LEAD FREE

Polarization Key Option

Tail Type
Note 12

A	B	C	D
Y	Y	N	N
STB	PF	STB	PF

4 BEAM PWR CONTACT QTY
(NEXT TO LEFT END)

2 BEAM PWR CONTACT QTY
(NEXT TO SIGNAL)

SIGNAL CONTACT QTY



Example: The configuration above is 10121506-241232BLF
STD VERT REC 36P32S with polarization key.
24P is 4 beam contact, 12P is 2 beam contact.

TABLE 3. PART NUMBER CODE. HPCE STD VERT REC P+S CONFIG

DIM	TABLE 2. LENGTH FORMULAS.
DIM A (13)	$(MM/8) \times 10.16 + (NN/4) \times 5.08 + (PP/2) \times 1.27 + 9.12$
DIM B	DIM "A" - 5.00
DIM C	DIM "A" - 2.34
DIM D	DIM "A" - 4.04
DIM E	DIM "A" - 5.30
DIM F (14)	$(MM/8-1) \times 10.16 + (NN/4-1) \times 5.08 + 13.34$ (WITH 4 BEAM CONTACT) 3.18 (WITHOUT 4 BEAM CONTACT)



EXAMPLE: 10121506-241232BLF

NOTES:

- CONNECTOR MATERIALS:
HOUSING: HIGH TEMPERATURE THERMAL PLASTIC, BLACK
UL 94V-0 COMPLIANT
CONTACTS: HIGH PERFORMANCE COPPER ALLOY.
- CONTACT FINISH REF. GS-12-604 SECTION 5.2.
- PRODUCT SPECIFICATION: GS-12-604.
- APPLICATION SPECIFICATION: GS-20-128.
- PRODUCT MARKING ON HOUSING IN AREA SHOWN MEETS AFCI SPECIFICATION: GS-24-007.
- PACKAGING MEETS FCI SPECIFICATION GS-14-937.
- HOUSING COMPONENT WILL WITHSTAND EXPOSURE TO 260°C PEAK TEMPERATURE FOR 60 SECONDS IN A CONVECTION, INFRA-RED, OR VAPOR PHASE REFLOW OVEN.
- COPPER PLATING THICKNESS IN CENTER OF VIA-HOLE CAN BE NO MORE THAN 0.003 LESS THAN OTHER AREAS.
- ALL HOLE SIZES ARE FINISHED HOLE SIZES.
- MOUNTING HOLES ARE UNPLATED
Ø 2.40 +/- 0.1 FOR PRESS-FIT TAILS
Ø 2.18 +/- 0.03 FOR SOLDER TAILS
- PRESS FIT APPLICATION TOOL DRAWING : 10119453.
- STB= SOLDER TO BOARD, 1.57-2.38mm PCB THICKNESS.
PF = PRESS FIT, 1.57mm MINIMUM PCB THICKNESS.
- MAXIMUM OVERALL LENGTH IS 100mm.

- DIM IS NOT APPLICABLE IF NO 4 BEAM CONTACT OR 2 BEAM CONTACT.
- A Δ SYMBOL WILL BE NEXT TO ANY DIMENSION, VIEW, OR NOTE WHICH HAS BEEN MODIFIED WITH THE CURRENT DRAWING REVISION.

spec ref	-	dr	Wei-Long Zhang	2012/07/05	projection	MM	size	A2	scale	1:1
tolerance std	ISO 406 ISO 1101	eng	Sunny2 Liu	2016/05/05			ecn no	ELX-DG-24036-1		
TOLERANCES UNLESS OTHERWISE SPECIFIED		chr	Terris Liu	2016/05/20				rel level	Released	
surface	linear	0.X	±0.3	Amphenol FCI	product family	STD VERT REC UNIVERSAL	dwg no	10121506		
		0.XX	±0.10			HIGH POWER CARD EDGE		rev	C	
	angular	0°	±2°		cat. no.	Product - Customer Drw	sheet 4 of 4			

Amphenol FCI

© 2016 AFCI

Данный компонент на территории Российской Федерации

Вы можете приобрести в компании MosChip.

Для оперативного оформления запроса Вам необходимо перейти по данной ссылке:

<http://moschip.ru/get-element>

Вы можете разместить у нас заказ для любого Вашего проекта, будь то серийное производство или разработка единичного прибора.

В нашем ассортименте представлены ведущие мировые производители активных и пассивных электронных компонентов.

Нашей специализацией является поставка электронной компонентной базы двойного назначения, продукции таких производителей как XILINX, Intel (ex.ALTERA), Vicor, Microchip, Texas Instruments, Analog Devices, Mini-Circuits, Amphenol, Glenair.

Сотрудничество с глобальными дистрибьюторами электронных компонентов, предоставляет возможность заказывать и получать с международных складов практически любой перечень компонентов в оптимальные для Вас сроки.

На всех этапах разработки и производства наши партнеры могут получить квалифицированную поддержку опытных инженеров.

Система менеджмента качества компании отвечает требованиям в соответствии с ГОСТ Р ИСО 9001, ГОСТ РВ 0015-002 и ЭС РД 009

Офис по работе с юридическими лицами:

105318, г.Москва, ул.Щербаковская д.3, офис 1107, 1118, ДЦ «Щербаковский»

Телефон: +7 495 668-12-70 (многоканальный)

Факс: +7 495 668-12-70 (доб.304)

E-mail: info@moschip.ru

Skype отдела продаж:

moschip.ru

moschip.ru_4

moschip.ru_6

moschip.ru_9