

350 Watts

- Rugged Industrial Construction
- -40 °C to +70 °C Operation
- Screw Terminals
- High Efficiency
- Remote On/Off
- ITE/Industrial & Medical Approvals
- Low Leakage Current
- Class B Emissions
- 3 Year Warranty



Dimensions:

SMP350:
3.6 x 7.0 x 1.7" (91.4 x 177.8 x 43.1 mm)

The SMP350 series provides a range of rugged, enclosed, 300 – 350W supplies with integral fan, screw terminal connections and a wide operating temperature range of -40 °C to +70 °C ideally suited to a wide range of industrial applications. The SMP350 series features high efficiency and class B EMI emissions for ease of integration into the end application and offers remote On/Off to simplify system control. Packaged in a 3.6" x 7" x 1.7" enclosure the series offers power densities up to 13 W/in³ providing a compact, high efficiency, low noise power solution.

Models & Ratings

Output Voltage V1	90-180 VAC		180-264 VAC		Model Number ⁽¹⁾
	Output Current	Output Power	Output Current	Output Power	
12.0 VDC	25.00 A	300 W	25.00 A	300 W	SMP350PS12
15.0 VDC	20.70 A	310 W	22.00 A	330 W	SMP350PS15
18.0 VDC	17.80 A	320 W	19.40 A	350 W	SMP350PS18
24.0 VDC	13.75 A	330 W	14.60 A	350 W	SMP350PS24
28.0 VDC	11.80 A	330 W	12.50 A	350 W	SMP350PS28
36.0 VDC	9.20 A	330 W	9.70 A	350 W	SMP350PS36
48.0 VDC	7.30 A	350 W	7.30 A	350 W	SMP350PS48

Notes

1. For reduced leakage current versions (<300 µA) contact sales.

Mechanical Details

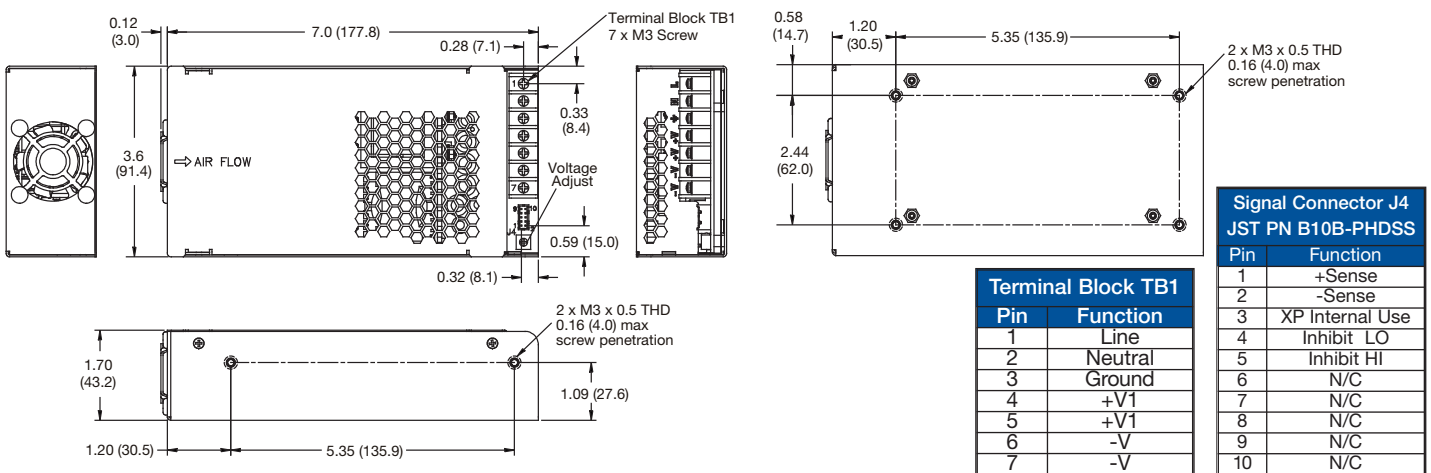

Notes

- All dimensions in inches (mm).
- Tolerance .xx = ±0.02 (0.50); .xxx = ±0.01 (0.25)
- Weight: 1.5 lbs (0.68 kg)
- J4 mates with JST Housing Pn. PHDR-10VS and with JST SPHD-001T-P0.5 crimp terminals.

Input

Characteristic	Minimum	Typical	Maximum	Units	Notes & Conditions
Input Voltage	85		264	VAC	Derate below 90 VAC to 90% load at 85 VAC
Input Frequency	47		63	Hz	
Power Factor		0.9			EN6100-3-2 for class A, Class C >125 W
Input Current			4.7	A	90 VAC, 100% load
No Load Input Power		1.25/2.6		W	115 VAC/230 VAC when inhibited
Inrush Current		130		A	230 VAC, cold start 25 °C
Earth Leakage Current			500	µA	264 VAC/60 Hz. For reduced leakage current medical versions (<300 µA) contact sales.
Fuse Protection	F5.0A/250V fitted in both line and neutral				

Output

Characteristic	Minimum	Typical	Maximum	Units	Notes & Conditions
Output Voltage	12		48	VDC	See Models and Ratings table
Initial Set Accuracy			±1	%	Of nominal at 50% load
Output Voltage Adjustment -V1	±2			%	
Load Regulation			1	%	
Line Regulation			±0.5	%	Of nominal, for input voltage range of 90-264 VAC
Ripple and Noise			1	%	Pk-pk with 20 MHz bandwidth, 1.5% 12 V models
Hold Up Time	10			ms	
Minimum Load					No minimum load required
Transient Response			<4	%	Deviation with a 50%-75%-50% load change. Output returns to within 1% in less than 500 µs
Overload Protection - V1	110		150	%	Trip and Restart
Overvoltage Protection - V1	115		140	%	Cycle AC to reset
Overtemperature Protection					Thermal protection fitted
Remote On/Off	<0.4 V to switch off, open cct or >4 V to switch on				
Temperature Coefficient			0.02	%/°C	After 20 minute warm up
Start Up Time			1	s	115/230 VAC, full load
Overshoot			5	%	

General

Characteristic	Minimum	Typical	Maximum	Units	Notes & Conditions
Efficiency	87	90	93	%	See figures 2 – 4 below
Isolation: Input to Output Input to Ground Output to Ground	4000			VAC	2 x MOPP
	1500			VAC	1 x MOPP
	1500			VAC	1 x MOPP
Switching Frequency	60		200	kHz	PFC
	90		150		Main Converter
Mean Time Between Failure		570		kHrs	MIL-HDBK-217F, notice 2, +25 °C GB
Power Density			13	W/in ³	
Weight		1.5 (0.68)		lb (kg)	

Efficiency Vs Load

Figure 2
12 V Models

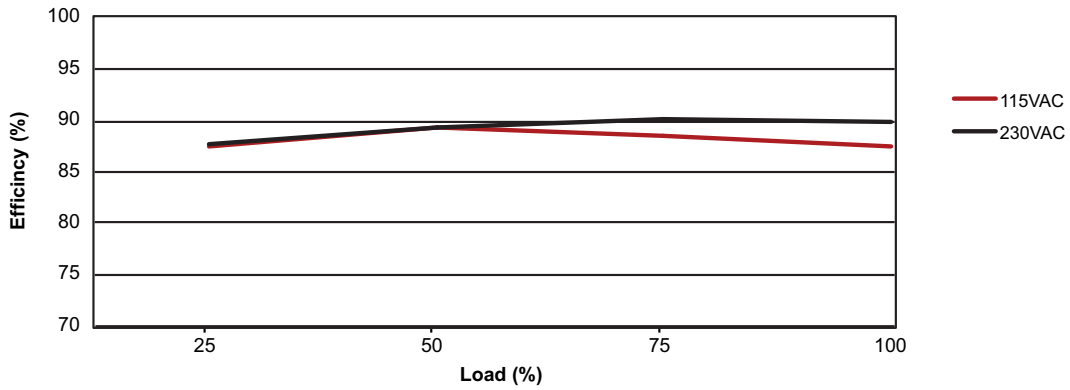

Figure 3
24 V Models

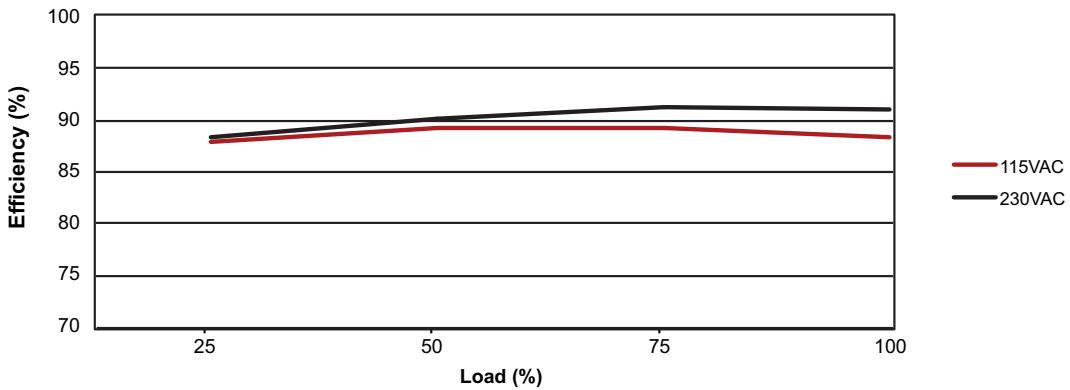
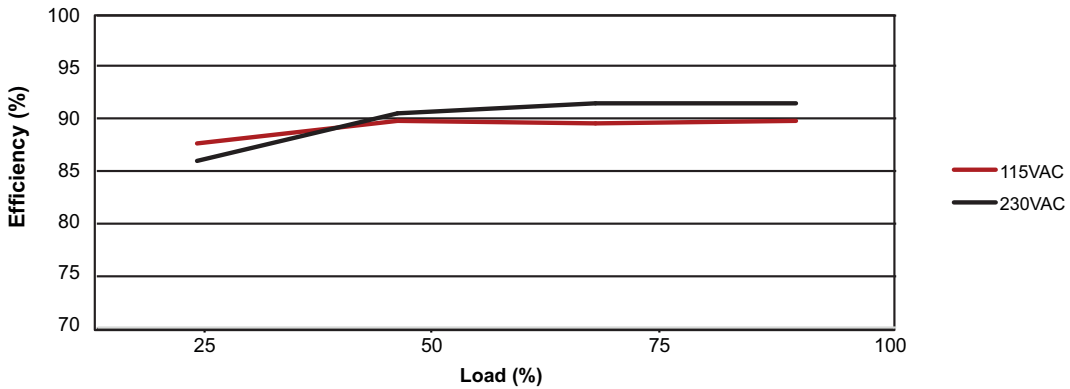

Figure 4
48 V Models



Environmental

Characteristic	Minimum	Typical	Maximum	Units	Notes & Conditions
Operating Temperature	-40		+70	°C	Derate linearly above 50 °C to 50% of rated power at 70 °C, see fig 5
Storage Temperature	-40		+85	°C	
Operating Humidity	5		95	%	RH, non-condensing
Storage Humidity	5		95	%	RH, non-condensing
Shock	±3 x 30 g shocks in each plane, total 18 shocks. 30 g = 11 ms (±0.5 ms), half sine. Conforms to EN60068-2-27 & EN60068-2-47				
Vibration	Single axis 10-500 Hz at 2 g sweep and endurance at resonance in all 3 planes. Conforms to EN60068-2-6				

Thermal Derating Curve

Figure 5

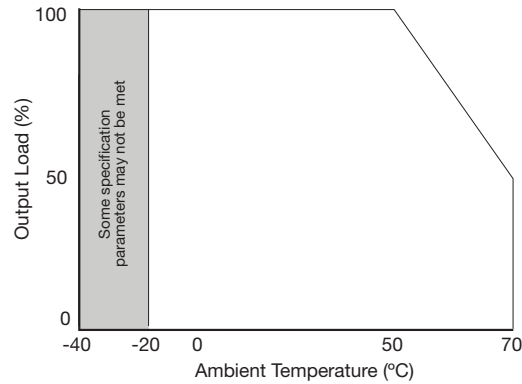

Signals & Controls

Characteristic		Notes & Conditions
Remote Sense		Compensates for 0.5 V total voltage drop
Remote On/Off	Inhibit	The inhibit lo (pin 4), should be pulled below 0.4 V to switch V1 & Vfan off. Open circuit or >4 V to switch on (see fig. 6)
	Enable	With the inhibit lo (pin 4) pulled low as detailed above, connecting inhibit hi (pin 5) to inhibit lo (pin 4) will enable V1 & V fan output. (see fig. 7)

Remote On/Off (Inhibit)

Figure 6

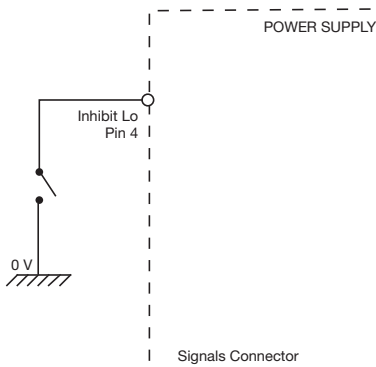

Remote On/Off (Enable)

Figure 7

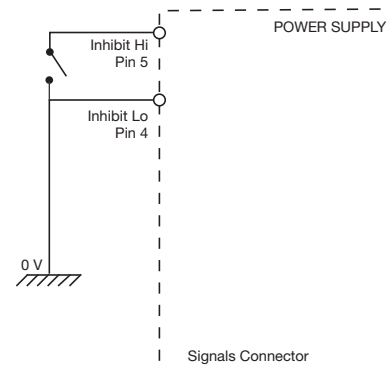

EMC: Emissions

Phenomenon	Standard	Test Level	Criteria	Notes & Conditions
Conducted	EN55011/32	Class B		
Radiated	EN55011/32	Class A		
Harmonic Fluctuations	EN61000-3-3			

EMC: Immunity

Phenomenon	Standard	Test Level	Criteria	Notes & Conditions
Low Voltage PSU EMC	EN61204-3	High severity level	as below	
Harmonic Current	EN61000-3-3	Class A		All models
		Class C		> 125 W
Radiated	EN61000-4-3	3	A	
EFT	EN61000-4-4	3	A	
Surges	EN61000-4-5	Installation class 3	A	
Conducted	EN61000-4-6	3	A	
Dips and Interruptions	EN61000-4-11 (100 VAC)	Dip 100% (0 VAC), 8.4ms	A	
		Dip 100% (0 VAC), 16.7ms	B	
		Dip 60% (40 VAC), 200ms	B	
		Dip 30% (70 VAC), 500ms	B	
		Dip 20% (80 VAC), 5000ms	B	
		Int 100% (0 VAC), 5000ms	B	
	EN61000-4-11 (240 VAC)	Dip 100% (0 VAC), 10ms	A	
		Dip 100% (0 VAC), 20ms	B	
		Dip 60% (96 VAC), 200ms	B	
		Dip 30% (168 VAC), 500ms	B	
		Dip 20% (192 VAC), 5000ms	B	
		Int 100% (0 VAC), 5000ms	B	
	EN60601-1-2 (100 VAC)	Dip 100% (0 VAC), 10ms	A	
		Dip 60% (40 VAC), 100ms	A	Derate Power to 150 W
		Dip 30% (70 VAC), 500ms	A	
		Int 100% (0 VAC), 5000ms	B	
	EN60601-1-2 (240 VAC)	Dip 100% (0 VAC), 10ms	A	
		Dip 60% (96 VAC), 100ms	A	
		Dip 30% (168 VAC), 500ms	A	
		Int 100% (0 VAC), 5000ms	B	
SEMI F47 (100 VAC)		Dip 33% (70 VAC), 500ms	A	

Safety Approvals

Safety Agency	Safety Standard	Notes & Conditions
CB Report	IEC60950-1:2005 Ed 2	Information Technology
	IEC62368-1 Ed 2	Information Technology
	IEC60601-1 Ed 3 Including Risk Management	Medical
UL	UL62368-1, CSA C22.2 No. 62368-1	Information Technology
	ANSI/AAMI ES60601-1:2005 & CSA C22.2, No.60601-1:08	Medical
TUV	EN62368-1	Information Technology
	EN60601-1/2006	Medical
CE	LVD & RoHS	
Equipment Protection Class	Class I	See safety agency conditions of acceptability for details

Means of Protection		Category
Primary to Secondary	2 x MOPP (Means of Patient Protection)	IEC60601-1 Ed 3
Primary to Earth	1 x MOPP (Means of Patient Protection)	
Secondary to Earth	1 x MOPP (Means of Patient Protection)	

Mechanical Details

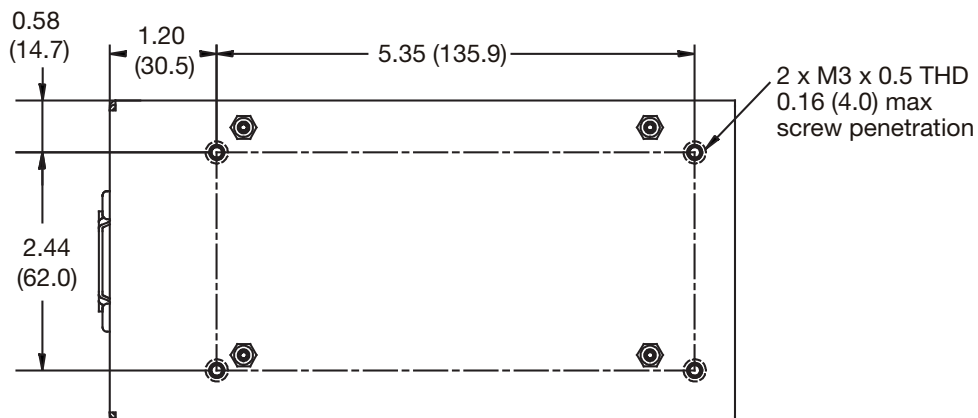
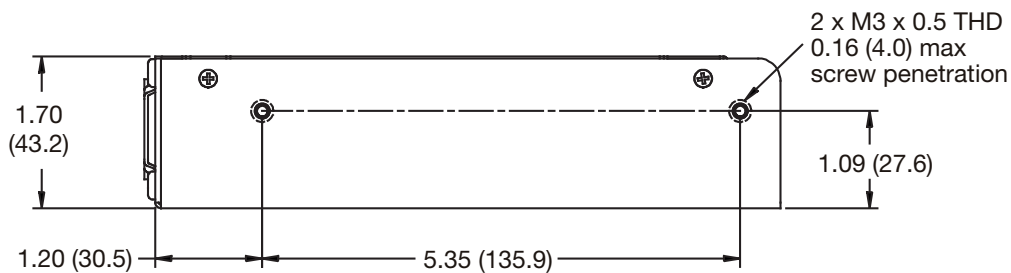
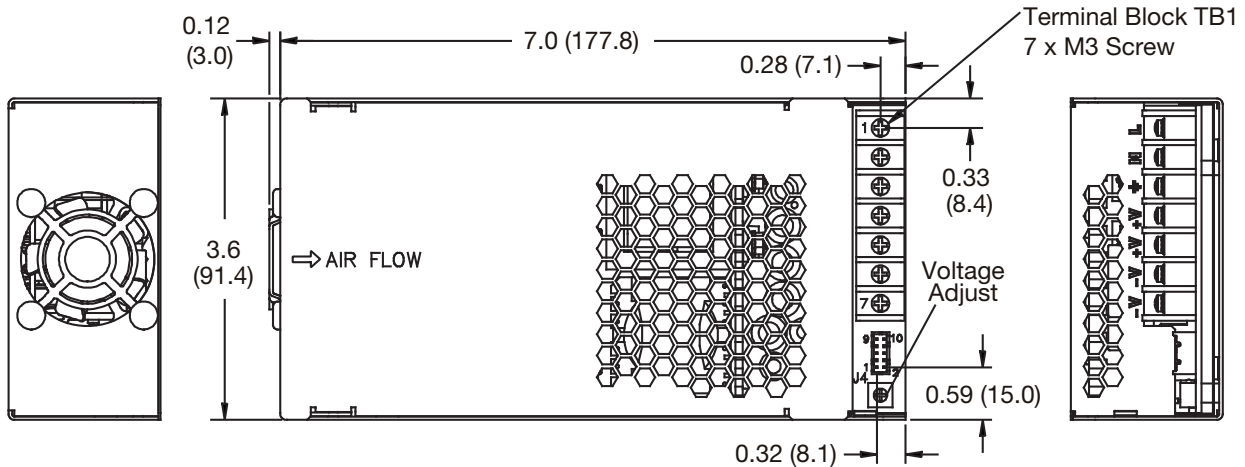

Notes

1. All dimensions in inches (mm).
2. Tolerance .xx = ± 0.02 (0.50); .xxx = ± 0.01 (0.25)
3. Weight: 1.5 lbs (0.68 kg)
4. J4 mates with JST Housing Pn. PHDR-10VS and with JST SPHD-001T-P0.5 crimp terminals.

Terminal Block TB1	
Pin	Function
1	Line
2	Neutral
3	Ground
4	+V1
5	+V1
6	-V
7	-V

Signal Connector J4 JST PN B10B-PHDSS	
Pin	Function
1	+Sense
2	-Sense
3	XP Internal Use
4	Inhibit LO
5	Inhibit HI
6	N/C
7	N/C
8	N/C
9	N/C
10	N/C

Данный компонент на территории Российской Федерации

Вы можете приобрести в компании MosChip.

Для оперативного оформления запроса Вам необходимо перейти по данной ссылке:

<http://moschip.ru/get-element>

Вы можете разместить у нас заказ для любого Вашего проекта, будь то серийное производство или разработка единичного прибора.

В нашем ассортименте представлены ведущие мировые производители активных и пассивных электронных компонентов.

Нашей специализацией является поставка электронной компонентной базы двойного назначения, продукции таких производителей как XILINX, Intel (ex.ALTERA), Vicor, Microchip, Texas Instruments, Analog Devices, Mini-Circuits, Amphenol, Glenair.

Сотрудничество с глобальными дистрибьюторами электронных компонентов, предоставляет возможность заказывать и получать с международных складов практически любой перечень компонентов в оптимальные для Вас сроки.

На всех этапах разработки и производства наши партнеры могут получить квалифицированную поддержку опытных инженеров.

Система менеджмента качества компании отвечает требованиям в соответствии с ГОСТ Р ИСО 9001, ГОСТ РВ 0015-002 и ЭС РД 009

Офис по работе с юридическими лицами:

105318, г.Москва, ул.Щербаковская д.3, офис 1107, 1118, ДЦ «Щербаковский»

Телефон: +7 495 668-12-70 (многоканальный)

Факс: +7 495 668-12-70 (доб.304)

E-mail: info@moschip.ru

Skype отдела продаж:

moschip.ru

moschip.ru_4

moschip.ru_6

moschip.ru_9