



Main

Range of product	OsiSense XU
Series name	Application material handling
Electronic sensor type	Photo-electric sensor
Sensor name	XUY
Sensor design	Compact 50 x 50
Detection system	Diffuse
Material	Plastic
Supply circuit type	DC
Wiring technique	4-wire
Analogue output range	0...10 V
Electrical connection	1 male connector M12, 4 pins
Product specific application	Measuring thickness of mechanical parts Position control of robot arm
Emission	Red laser, pulsed (class 1), wavelength: 650 nm conforming to IEC 825-1
[Sn] nominal sensing distance	45...85 mm

Complementary

Enclosure material	ABS, anti-shock
Pulse frequency	6 kHz
Linearity	< 1 %
Spot diameter	0.03 in (0.8 mm) at 65 mm
Spot dimension	Ø 0.8 mm at 65 mm
Resolution	20 µm
Status LED	1 LED (green) supply on 1 LED (red) dirty
[Us] rated supply voltage	24 V DC with reverse polarity protection
Supply voltage limits	18...28 V DC
Switching capacity in mA	3 mA (overload and short-circuit protection)
Switching frequency	< 40 Hz
Voltage drop	<= 2.4 V (closed state)
Current consumption	35 mA (no-load)
Delay response	30 ms output circuit
Setting-up	Parametering by buttons
Product weight	0.13 lb(US) (0.057 kg)

Environment

product certifications	CE
ambient air temperature for operation	32...113 °F (0...45 °C)
ambient air temperature for storage	-4...140 °F (-20...60 °C)
immunity to ambient light	5000 lux with natural light
vibration resistance	7 gn, amplitude = +/- 1.5 mm (f = 10...55 Hz) conforming to IEC 60068-2-6
shock resistance	30 gn (duration = 11 ms) conforming to IEC 60068-2-27
IP degree of protection	IP67 conforming to IEC 60529

Offer Sustainability

WARNING: This product can expose you to chemicals including:

WARNING: This product can expose you to chemicals including:

The information provided in this documentation contains general descriptions and/or technical characteristics of the products contained herein. This documentation is not intended as a substitute for and is not to be used for determining suitability or reliability of these products for specific user applications. It is the duty of any such user or integrator to perform the appropriate and complete risk analysis, evaluation and testing of the products with respect to the relevant specific application or use thereof. Neither Schneider Electric Industries SAS nor any of its affiliates or subsidiaries shall be responsible or liable for misuse of the information contained herein.

Diisononyl phthalate (DINP), which is known to the State of California to cause cancer, and Diisononyl phthalate (DINP), which is known to the State of California to cause cancer, and

Diisodecyl phthalate (DIDP), which is known to the State of California to cause birth defects or other reproductive harm. Diisodecyl phthalate (DIDP), which is known to the State of California to cause birth defects or other reproductive harm.

For more information go to www.p65warnings.ca.gov For more information go to www.p65warnings.ca.gov

Contractual warranty

Warranty period 18 months

Dimensions

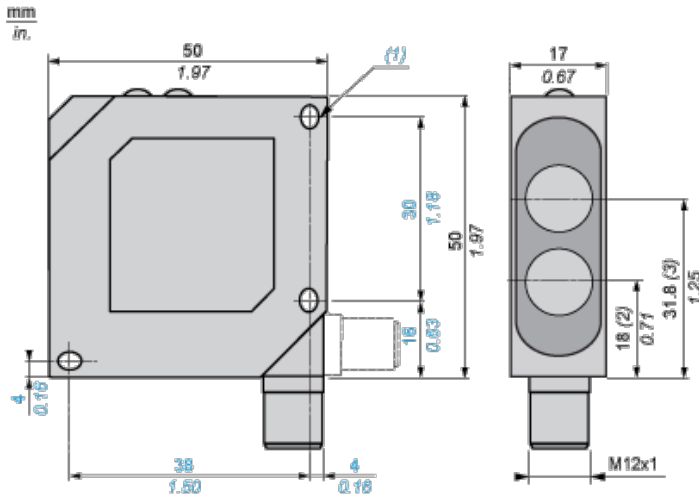

- (1) 2 elongated holes \varnothing 4.3 x 4
- (2) Transmitter optical axis
- (3) Receiver optical axis

Wiring Schemes

M12

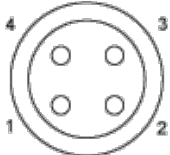

- 1 : Brown
- 2 : White
- 3 : Blue
- 4 : Black

PNP Output

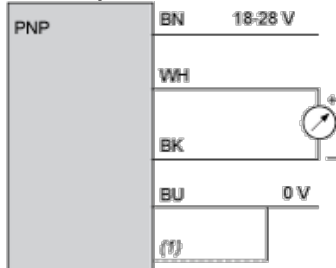

- (+) Brown
- BN :
- WH :White
- (-) Blue
- BU :
- BK : Black
- (1) Shielding

NOTE: Shielded cable recommended

Adjustment Curves

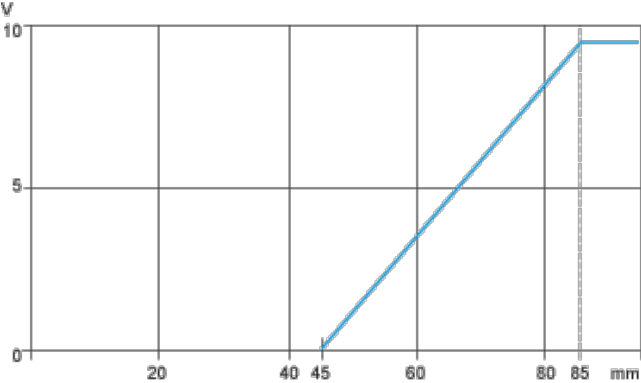

Данный компонент на территории Российской Федерации

Вы можете приобрести в компании MosChip.

Для оперативного оформления запроса Вам необходимо перейти по данной ссылке:

<http://moschip.ru/get-element>

Вы можете разместить у нас заказ для любого Вашего проекта, будь то серийное производство или разработка единичного прибора.

В нашем ассортименте представлены ведущие мировые производители активных и пассивных электронных компонентов.

Нашей специализацией является поставка электронной компонентной базы двойного назначения, продукции таких производителей как XILINX, Intel (ex.ALTERA), Vicor, Microchip, Texas Instruments, Analog Devices, Mini-Circuits, Amphenol, Glenair.

Сотрудничество с глобальными дистрибьюторами электронных компонентов, предоставляет возможность заказывать и получать с международных складов практически любой перечень компонентов в оптимальные для Вас сроки.

На всех этапах разработки и производства наши партнеры могут получить квалифицированную поддержку опытных инженеров.

Система менеджмента качества компании отвечает требованиям в соответствии с ГОСТ Р ИСО 9001, ГОСТ РВ 0015-002 и ЭС РД 009

Офис по работе с юридическими лицами:

105318, г.Москва, ул.Щербаковская д.3, офис 1107, 1118, ДЦ «Щербаковский»

Телефон: +7 495 668-12-70 (многоканальный)

Факс: +7 495 668-12-70 (доб.304)

E-mail: info@moschip.ru

Skype отдела продаж:

moschip.ru

moschip.ru_4

moschip.ru_6

moschip.ru_9