

## NEW! PAN1325A/1315A SERIES BLUETOOTH® HIGH TEMPERATURE MODULES

### Texas Instruments NEW CC2560A Bluetooth IC In An Easy-To-Use Module Format

Introducing the **NEW PAN1325A/1315A Series** Bluetooth RF Modules from Panasonic, now providing Texas Instruments' **NEW CC2560A** controller in an easy-to-use RF Module format with Bluetooth, FCC, IC and CE certifications. A ROM update from Texas Instruments to the already popular CC2560 IC has allowed Panasonic to improve its top selling PAN1325/1315 Series. The **NEW PAN1325A/1315A Series** Modules has increased power and system efficiency resulting from reduced initialization script size, start-up time and decreased system memory requirements.

All of Panasonic's Bluetooth RF Modules feature unique, tiny footprint technology and are designed to accommodate PCBs with pad pitch of 1.3mm with as little as two layers for easy implementation and manufacturing. With or without an embedded antenna, **the NEW PAN1325A/1315A Series** provides easily integrated Bluetooth connectivity into new and current designs by removing RF design and certification barriers from the application.

As the newest addition to Panasonic's Host Controlled Interface (HCI) Bluetooth RF Module product line, the **PAN1325A/1315A Series** has all the features of the existing and proven PAN1325/1315 Series but with the added benefits of the improved efficiency.

An updated initialization script is required for modules based on the CC2560A. Compatibility of CC2560 and CC2560A based products is a function of Bluetoothstack firmware residing on the host processor.

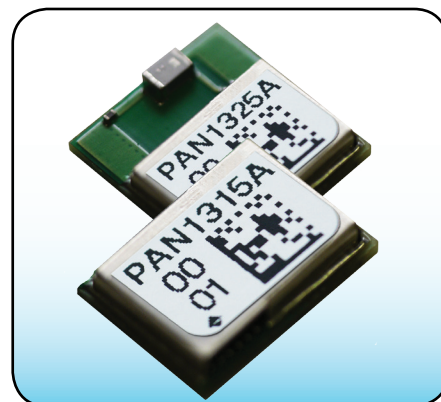

**BT component, CE and FCC certified.**  
(ETSI and IC certifications are pending.)



### Product Performance:

- Best-in-class Bluetooth RF performance (Tx power, Rx sensitivity, blocking)
- Fully Qualified Bluetooth v2.1 EDR
- Dimensions PAN1325A: 9mm x 9.5mm x 1.8mm (width x length x height)
- Dimensions PAN1315A: 6.5mm x 9mm x 1.7mm (width x length x height)
- Certifications: Bluetooth, CE, FCC
- Operating Temperature Range: -40°C to +85°C
- Supply Voltage Range: 1.7 - 4.8V
- Profiles: SPP, HDP, A2DP
- Based upon TI's CC2560A
- Integrates with TI's ultra low-power MSP430 microprocessor
- Very fast algorithm for both ACL and eSCO
- Supports Extended Range Tx power with 10dBm typical output (10dBm for PAN1315)
- Low power scan method for page and inquiry scans at 1/3rd normal power

### PAN1325A and 1315A Part Numbers:

Part Numbers	Description
ENW-89829A2KF	PAN1325A, CC2560A, HCI Module, Antenna
ENW-89829C2KF	PAN1315A, CC2560A, HCI Module, No Antenna

### Development and Evaluation Part Numbers:

Part Numbers	Description
ENW-89825A2JF	PAN1323ETU, Development Module for PAN1315, PAN1316, PAN1317, PAN1325, PAN1326, PAN1327
EVAL_PAN1323	EVAL_PAN1323, Development Kit for PAN1315, PAN1316, PAN1317, PAN1325, PAN1326, PAN1327

# Panasonic

## Interfaces:

The PAN1325A/PAN1315A Host Controlled Interface supports several transport layers with the following features:

- UART Rates of up to 4Mbps
- Three and Four Wire UART Transport

## Applications:

- Consumer Health Devices
  - Heart Rate Monitor
  - Blood Pressure Sensor
  - Blood Glucose Meter
  - Thermometer
  - Fitness Sensors
- Assisted Living
  - Flood Alarm
  - Heating Control
  - Automatic Key Control
- Industrial Sensors
- Toys
- Entertainment Devices
- Mobile Accessories
- All Bluetooth Wireless Applications

## Block Diagram PAN1325A:

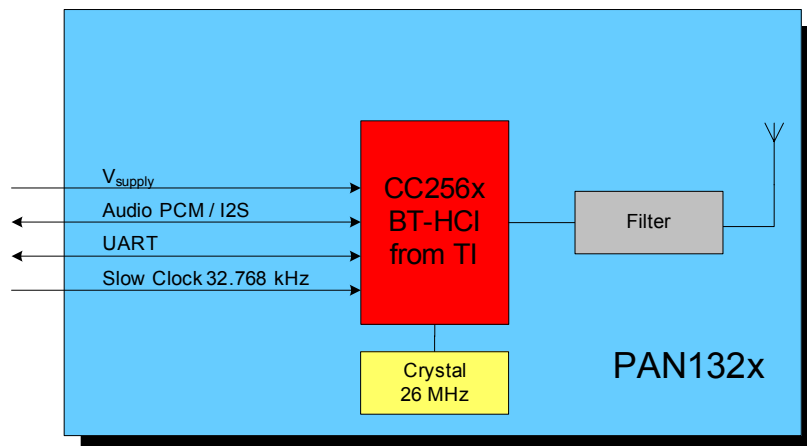

## Block Diagram PAN1315A:

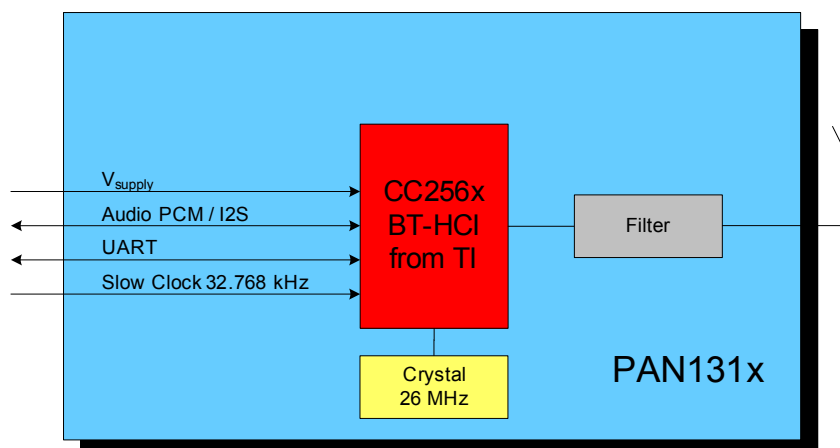

## Technical Specifications:

Parameter	Value		Condition / Notes
	PAN1325A	PAN1315A	
Receiver Sensitivity (BER=10 <sup>-3</sup> )	-93 dBm	-93 dBm	GFSK, Typical, Dirty TX On
Output Power	10 dBm	10.5 dBm	VDD_In = VBAT
Power Supply	1.7 - 4.8 V	1.7 - 4.8 V	Battery or DC/DC
Ultra Low Power Scan	135 $\mu$ A	135 $\mu$ A	1.28s Interval
GFSK DH1\DH5	33 mA	33 mA	Full Throughput
Operating Temperature Range	-40°C to + 85°C	-40°C to + 85°C	

## Данный компонент на территории Российской Федерации

### Вы можете приобрести в компании MosChip.

Для оперативного оформления запроса Вам необходимо перейти по данной ссылке:

<http://moschip.ru/get-element>

Вы можете разместить у нас заказ для любого Вашего проекта, будь то серийное производство или разработка единичного прибора.

В нашем ассортименте представлены ведущие мировые производители активных и пассивных электронных компонентов.

Нашей специализацией является поставка электронной компонентной базы двойного назначения, продукции таких производителей как XILINX, Intel (ex.ALTERA), Vicor, Microchip, Texas Instruments, Analog Devices, Mini-Circuits, Amphenol, Glenair.

Сотрудничество с глобальными дистрибьюторами электронных компонентов, предоставляет возможность заказывать и получать с международных складов практически любой перечень компонентов в оптимальные для Вас сроки.

На всех этапах разработки и производства наши партнеры могут получить квалифицированную поддержку опытных инженеров.

Система менеджмента качества компании отвечает требованиям в соответствии с ГОСТ Р ИСО 9001, ГОСТ РВ 0015-002 и ЭС РД 009

### Офис по работе с юридическими лицами:

105318, г.Москва, ул.Щербаковская д.3, офис 1107, 1118, ДЦ «Щербаковский»

Телефон: +7 495 668-12-70 (многоканальный)

Факс: +7 495 668-12-70 (доб.304)

E-mail: [info@moschip.ru](mailto:info@moschip.ru)

Skype отдела продаж:

moschip.ru

moschip.ru\_4

moschip.ru\_6

moschip.ru\_9