

Switching Regulator Series

Step-Down DC/DC Converter BD9C601EFJ Evaluation Board

BD9C601EFJ-EVK-001

Description

This evaluation board has been developed for ROHM's synchronous buck DC/DC converter customers evaluating BD9C601EFJ. While accepting a power supply of 7.2-18V, an output of 5.0V can be produced. The IC has internal 50mΩ high-side P-channel MOSFET and 35mΩ low-side N-channel MOSFET and a synchronization frequency is of 500kHz. A Soft Start circuit prevents in-rush current during startup. An EN pin allows for simple ON/OFF control of the IC to reduce standby current consumption. Include OCP (Over Current Protection) and SCP (Short Circuit Protection).

Evaluation Board Operating Limits and Absolute Maximum Ratings (Ta=25°C)

| Parameter | Symbol | Limit | | | Unit | Conditions |
|-----------------------------|------------------|----------------|-----|-----|------|------------|
| | | MIN | TYP | MAX | | |
| Supply Voltage | V _{CC} | (NOTE1) 4.5 | - | 18 | V | |
| Output Voltage / Current | V _{OUT} | - | 5.0 | - | V | |
| | I _{OUT} | - | - | 6 | A | |

(NOTE1) When the output voltage is 5.0V, it is 7.2V by limiting ratio of the maximum duty.

Evaluation Board

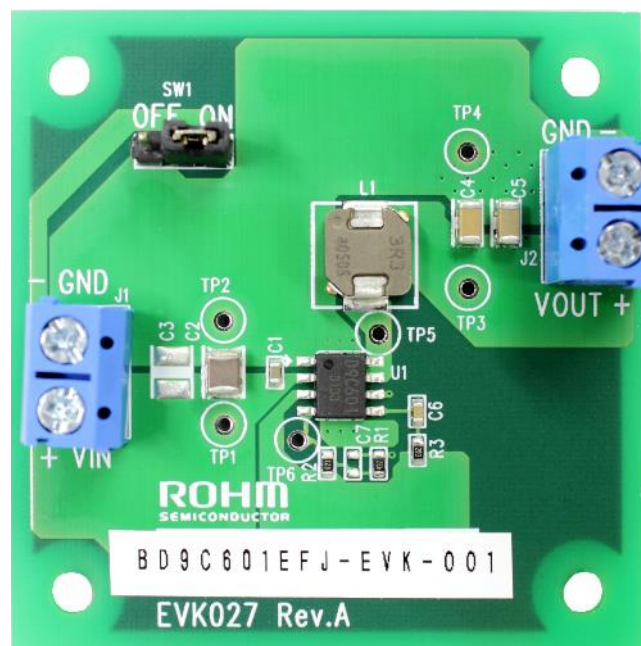

Figure 1. BD9C601EFJ-EVK-001 Evaluation Board

Operation Procedures

1. Necessary equipments

- (1) DC power-supply of 7.2V to 18V/6A
- (2) Maximum 6A load
- (3) DC voltmeter

2. Connecting the equipments

- (1) DC power-supply presets to 12V and then the power output turns off.
- (2) The max. load should be set at 6A and over it will be disabled.
- (3) Check Jumper pin of SW1 is short, between intermediate-terminal and OFF-side terminal.
- (4) Connect positive-terminal of power-supply to VIN+terminal and negative-terminal to GND-terminal with a pair of wires.
- (5) Connect load's positive-terminal to VOUT+terminal and negative-terminal to GND-terminal with a pair of wires.
- (6) Connect positive-terminal of DC voltmeter 1 to TP1 and negative-terminal to TP2 for input-voltage measurement.
- (7) Connect positive-terminal of DC voltmeter 2 to TP3 and negative-terminal to TP4 for output-voltage measurement.
- (8) DC power-supply output is turned ON.
- (9) IC is enable (EN) by shorting Jumper-pin of SW1 between intermediate-terminal and ON-side terminal.
- (10) Check DC voltmeter 2 displays 5.0V.
- (11) The load is enabled.
- (12) Check at DC voltmeter 1 whether the voltage-drop (loss) is not caused by the wire's resistance.

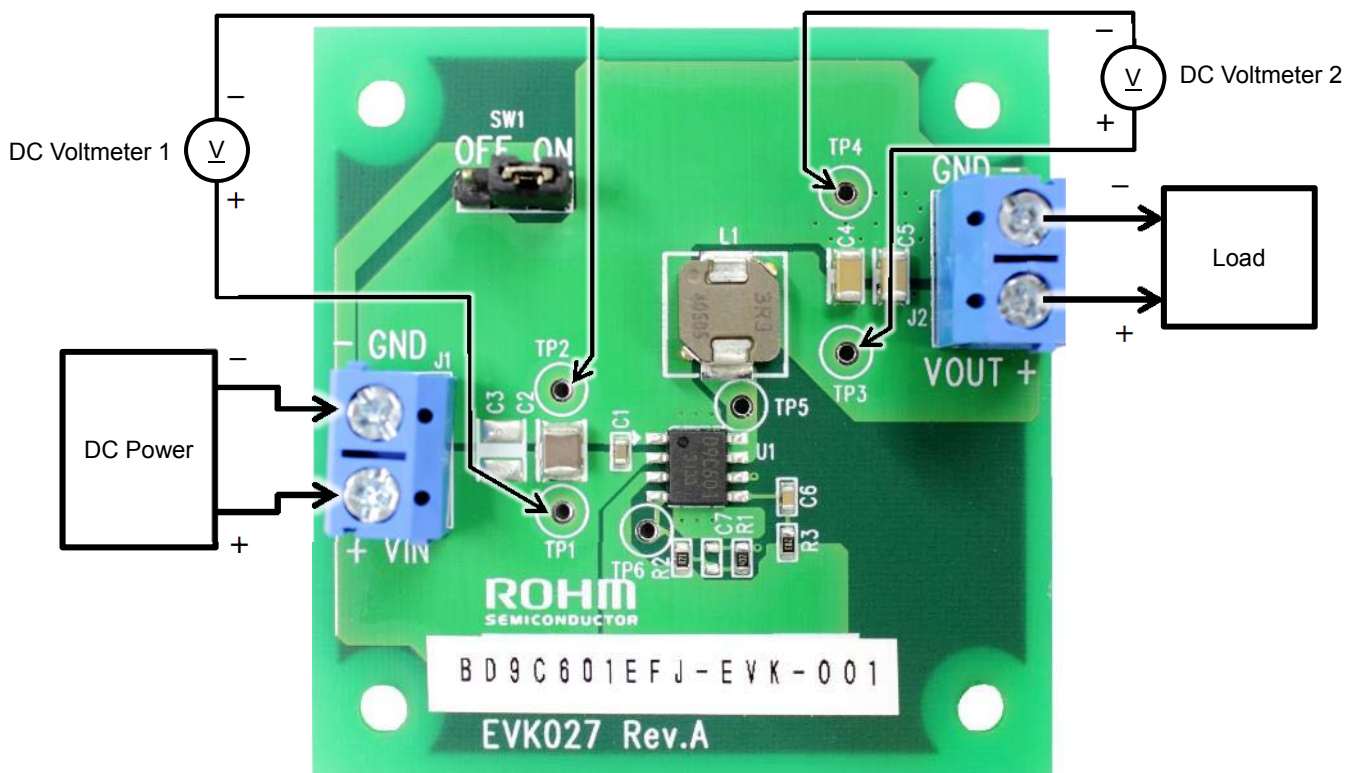

Figure 2. Connection Diagram

Enable-Pin

To minimize current consumption during standby-mode and normal operation, Enable-mode can be switched by controlling EN pin (6pin) of the IC. Standby-mode is enabled by shorting Jumper-pin of SW1 between intermediate-terminal and OFF-side terminal and normal-mode operation by shorting between intermediate-terminal and ON-side terminal.

It also can be switched between standby-mode and normal-mode operation by removing Jumper-pin and controlling the voltage between EN and GND-terminal. Standby-mode is enabled when the voltage of EN is under 0.8V, and normal-mode operation when it is over 2.0V.

Circuit Diagram

$V_{IN} = 7.2V \sim 18V, V_{OUT} = 5.0V$

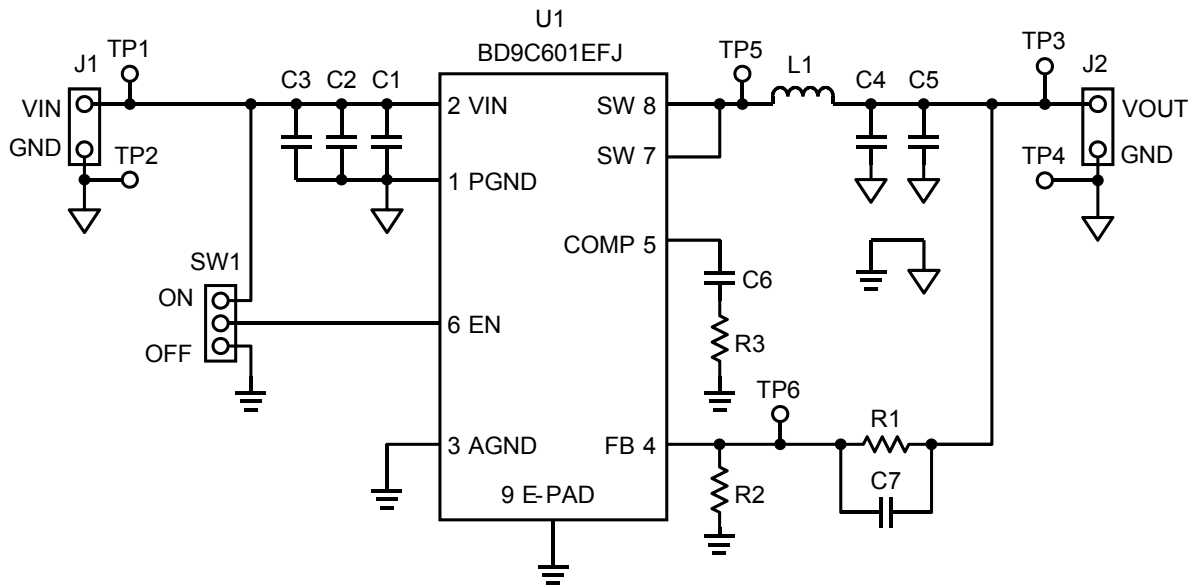

Figure 3. BD9C601EFJ-EVK-001 Circuit Diagram

Bill of Materials

| Count | Reference Designator | Type | Value | Description | Manufacturer Part Number | Manufacturer | Configuration (mm) |
|-------|----------------------|-------------------|---------------|---|--------------------------|-------------------------------|--------------------|
| 1 | C1 | Ceramic Capacitor | 0.1 μ F | 50V, B, \pm 20% | GRM188B31H104MA92 | MURATA | 1608 |
| 1 | C2 | Ceramic Capacitor | 10 μ F | 35V, B, \pm 10% | GRM32EB3YA106KA12 | MURATA | 3225 |
| 0 | C3 | Ceramic Capacitor | - | Not installed | - | - | 3225 |
| 2 | C4, C5 | Ceramic Capacitor | 22 μ F | 10V, B, \pm 10% | GRM31CB31A226KE19 | MURATA | 3216 |
| 1 | C6 | Ceramic Capacitor | 1500pF | 25V, B, \pm 10% | GRM188B11E152KA01 | MURATA | 1608 |
| 0 | C7 | Ceramic Capacitor | - | Not installed | - | - | 3216 |
| 1 | L1 | Inductor | 3.3 μ H | \pm 20%, DCR=29.7m Ω max, 7.3A | SPM6530T-3R3 | TDK | 7165 |
| 1 | R1 | Resistor | 4.3k Ω | 1/10W, 50V, 1% | MCR03ERPF4301 | ROHM | 1608 |
| 1 | R2 | Resistor | 820 Ω | 1/10W, 50V, 1% | MCR03ERPF8200 | ROHM | 1608 |
| 1 | R3 | Resistor | 20k Ω | 1/10W, 50V, 1% | MCR03ERPF2002 | ROHM | 1608 |
| 1 | SW1 | Pin header | - | 2.54mm \times 3 contacts | PH-1x03SG | USECONN | - |
| 1 | U1 | IC | - | Buck DC/DC Converter | BD9C601EFJ | ROHM | HTSOP-J8 |
| 2 | J1, J2 | Terminal Block | - | 2 contacts, 15A, 14 to 22AWG | TB111-2-2-U-1-1 | Alphaplus Connectors & Cables | - |
| 1 | - | Jumper | - | Jumper pin for SW1 | MJ254-6BK | USECONN | - |

Layout

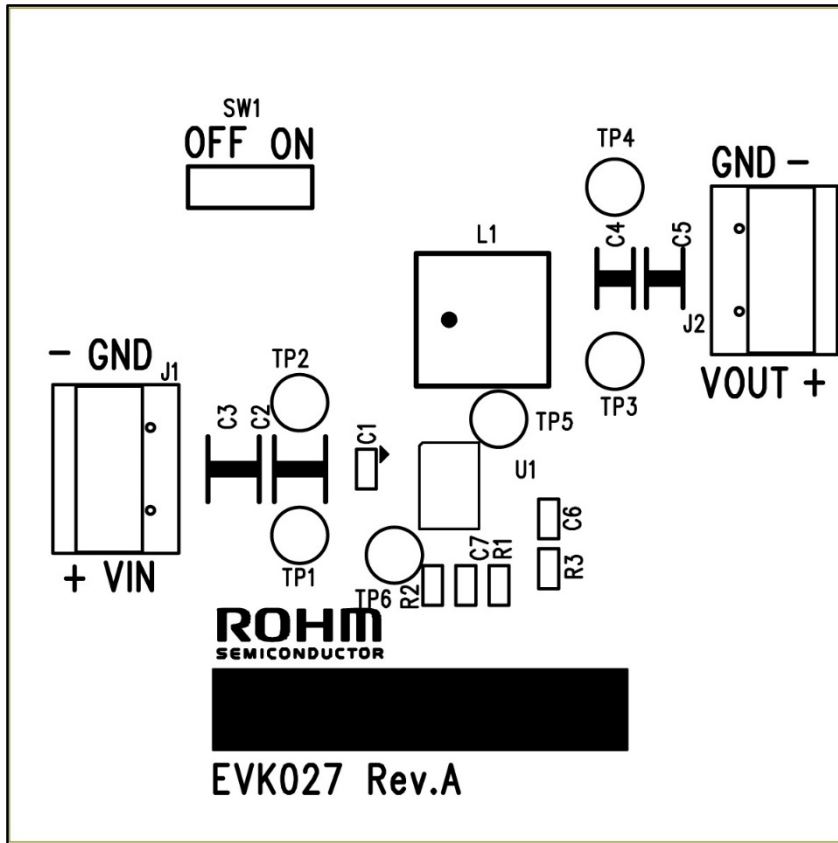

Figure 4. Top Silk Screen (Top view)

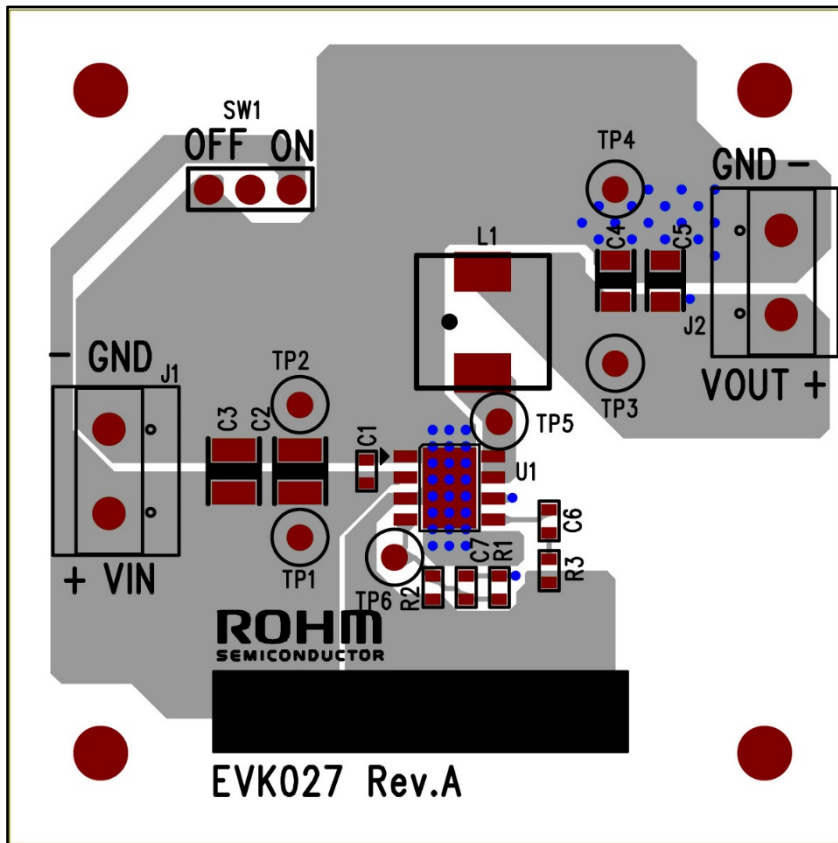

Figure 5. Top Silk Screen and Layout (Top view)

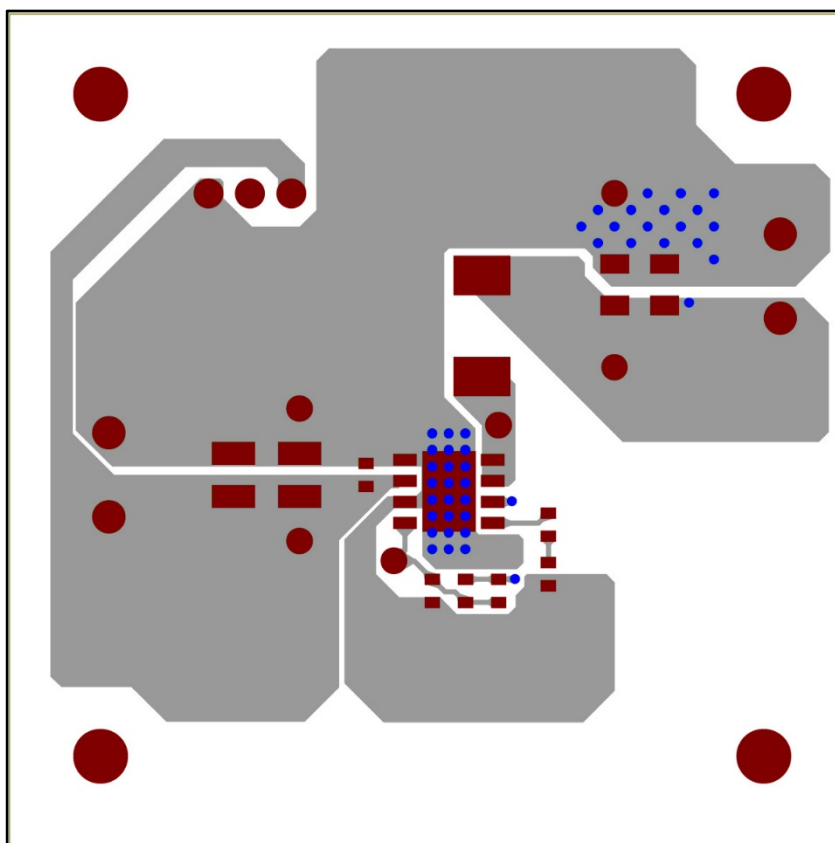

Figure 6. Top Side Layout (Top view)

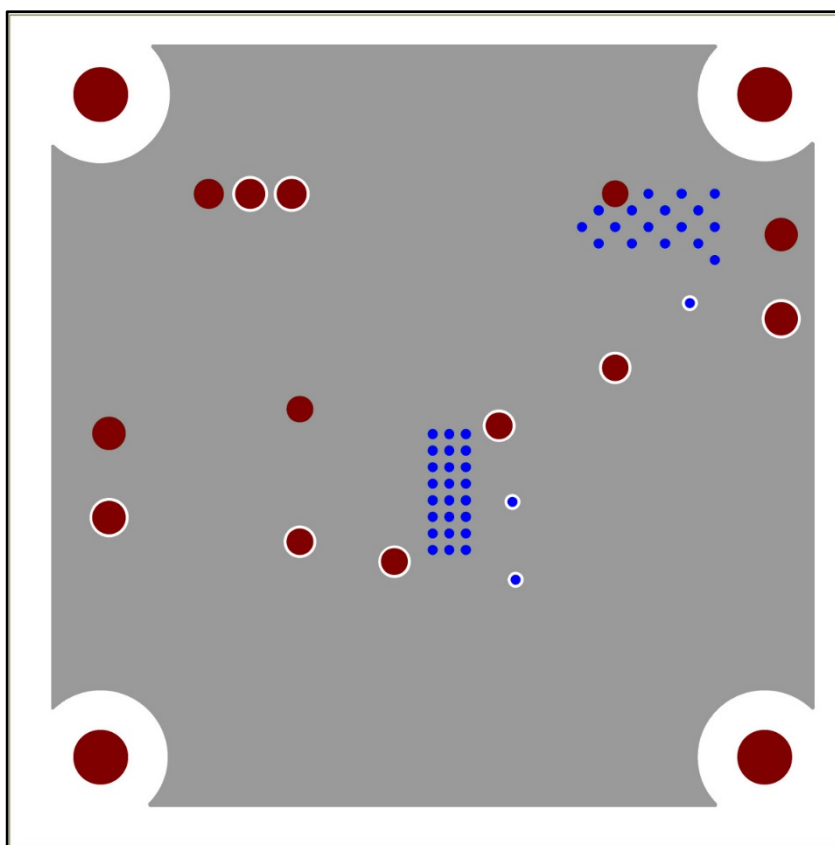

Figure 7. L2 Layout (Top view)

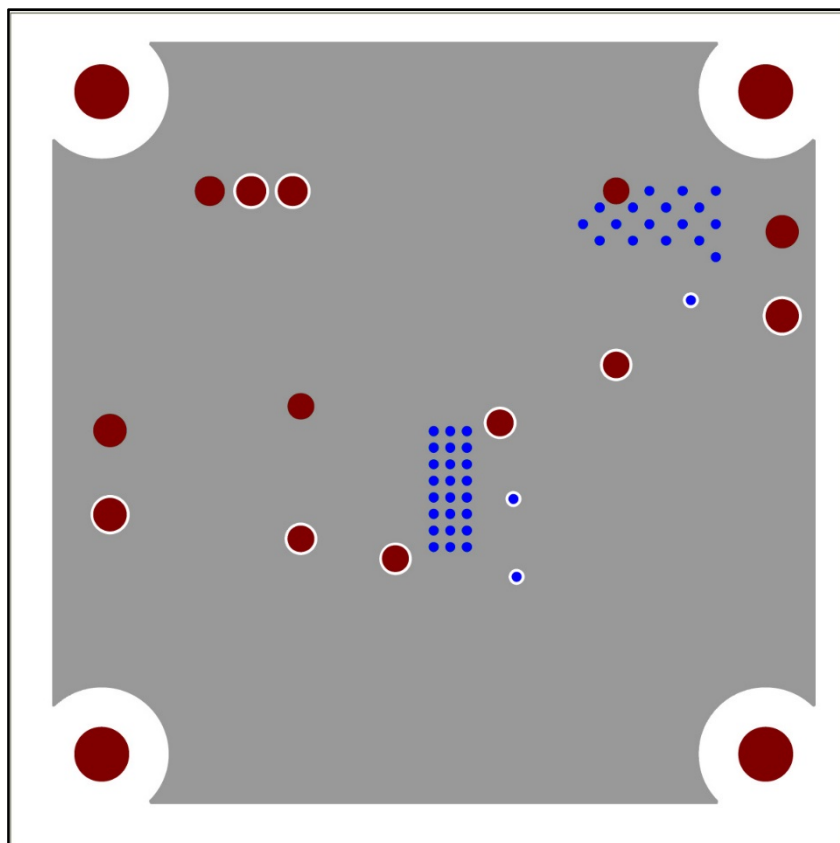

Figure 8. L3 Layout (Top view)

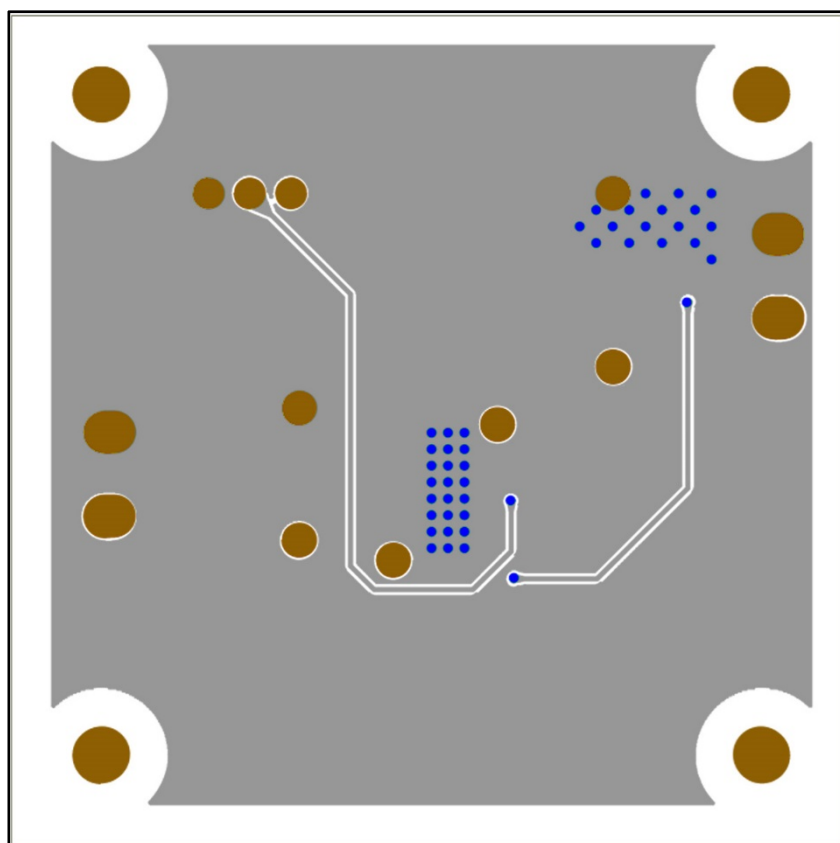

Figure 9. Bottom Side Layout (Top view)

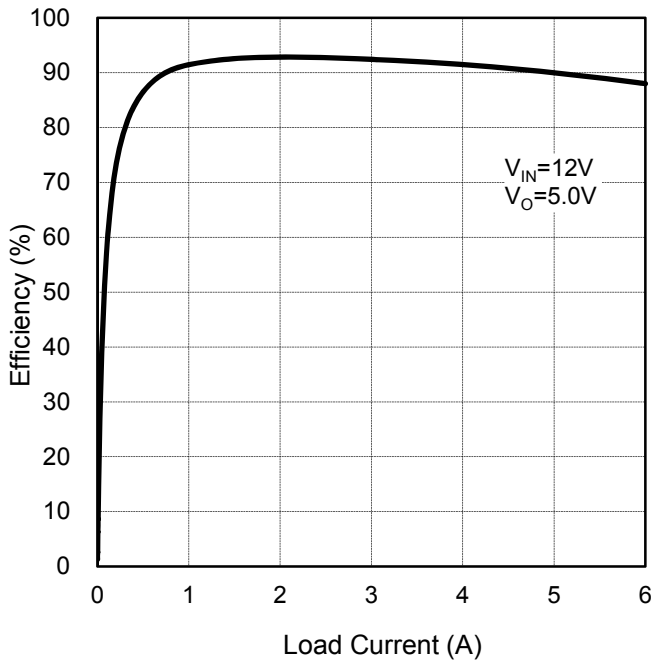

Figure 10. Efficiency vs Load Current

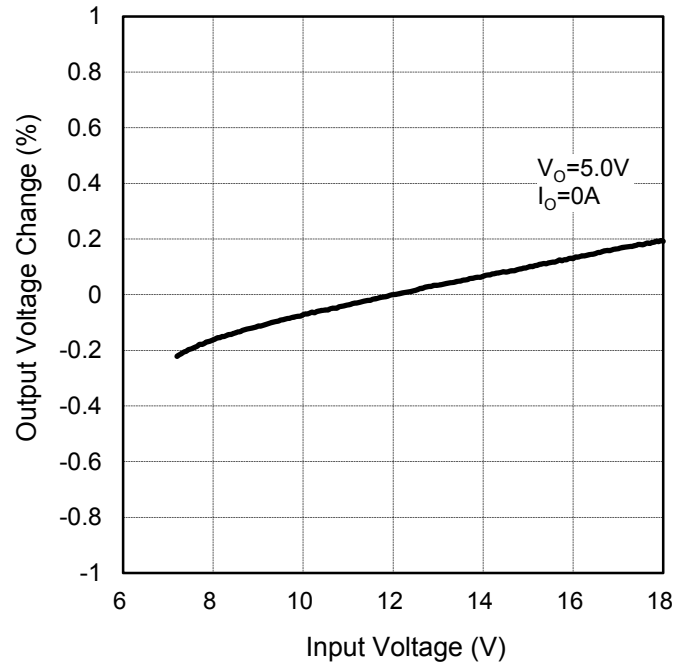

Figure 11. Efficiency vs Load Current

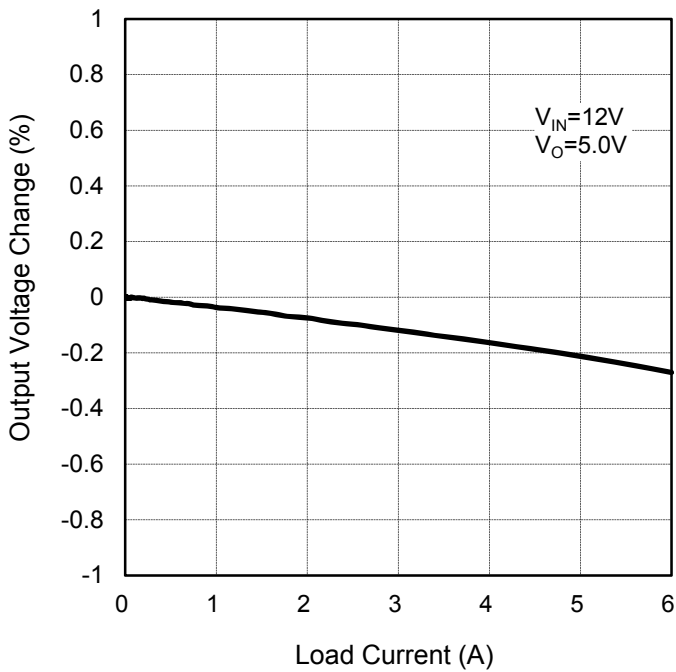

Figure 12. Load Regulation

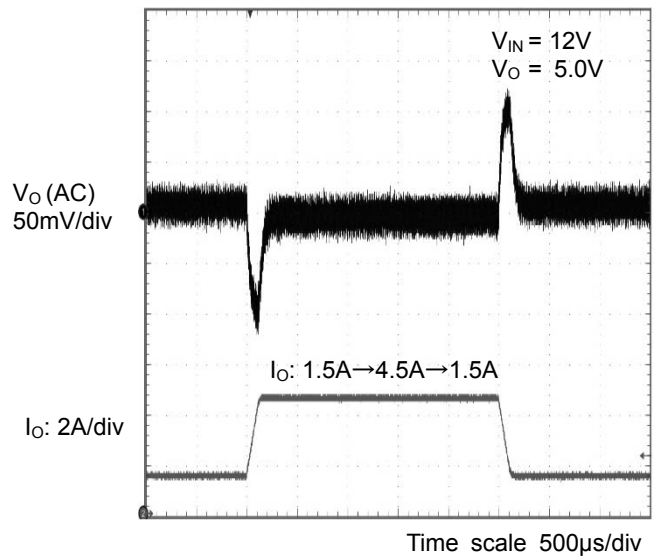

Figure 13. Load Transient Characteristics

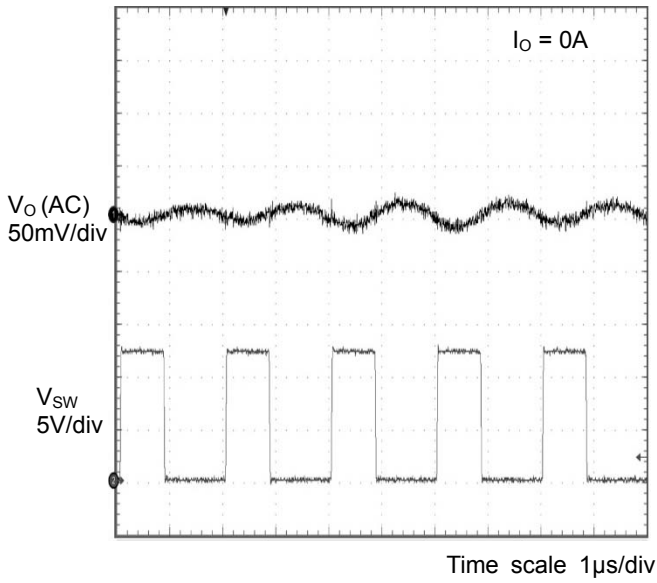

Figure 14. Output Voltage Ripple Wave
 $V_{IN} = 12V, V_O = 5.0V$

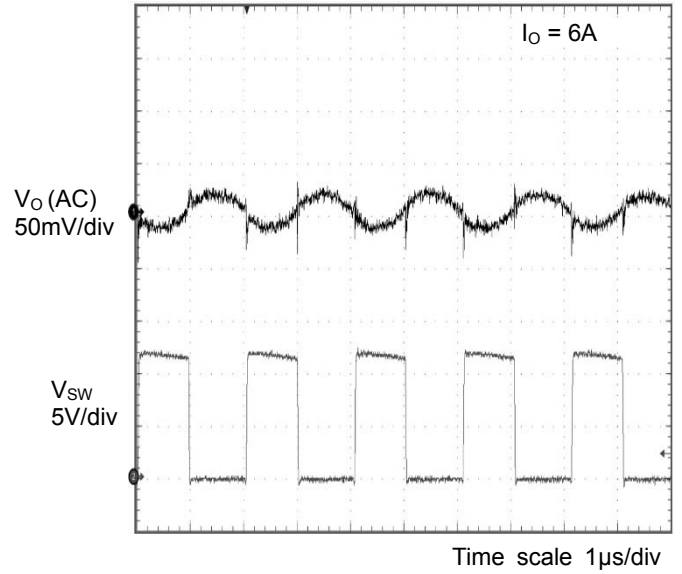

Figure 15. Output Voltage Ripple Wave
 $V_{IN} = 12V, V_O = 5.0V$

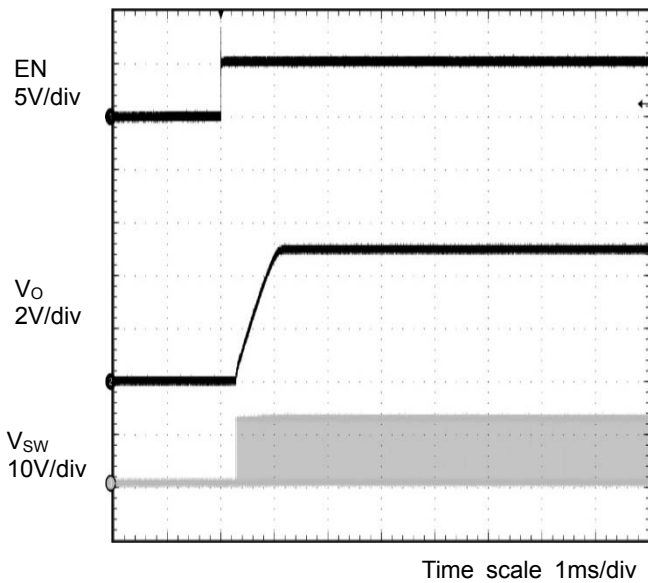

Figure 16. Start-up by EN
 $V_{IN} = 12V, V_O = 5.0V, I_o = 0A$

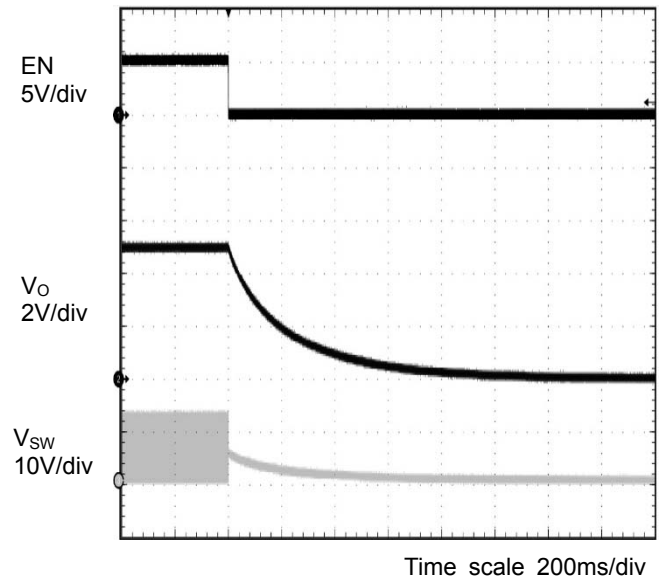

Figure 17. Power-down by EN
 $V_{IN} = 12V, V_O = 5.0V, I_o = 0A$

Notes

No copying or reproduction of this document, whole or in part, is permitted without the consent of ROHM Co., Ltd.

The contents specified herein are subject to change without notice.

The information contained in this document are for the purpose of introducing ROHM products (hereinafter "Products"). When using any such Products, please be sure to refer to the specifications, which can be obtained from ROHM upon request.

Examples of application circuits, circuit constants and any other information contained herein illustrate the standard usage and operation of the Products, and peripheral conditions must be taken into account when designing circuits for mass production.

Great care was taken in ensuring the accuracy of the information specified in this document. However, ROHM shall bear no responsibility for any damages incurred from inaccuracies or the misprint of information.

The technical information specified herein is intended only to show the typical functions and examples of application circuits for the Products. ROHM does not grant, either explicitly or implicitly, any license to use or exercise intellectual property or other rights held by ROHM and other parties. And ROHM shall bear no responsibility whatsoever for any disputes arising from the use of such technical information.

The Products specified in this document are intended to be used with general-use electronic equipment or devices (such as audio visual equipment, office automation equipment, communication devices, electronic appliances, and gaming systems).

The Products specified in this document are not designed to be radiation tolerant.

While ROHM makes every effort to enhance the quality and reliability of its Products, Products may fail or malfunction for a variety of reasons.

Please be sure to implement safety measures to guard against the possibility of physical injury, fire or any other damage that may arise due to Product failure, such as derating, redundancy, fire control and fail-safe designs. ROHM shall bear no responsibility whatsoever for the use of any Product outside of the prescribed scope or not in accordance with the instruction manual.

The Products are not designed or manufactured to be used with any equipment, device or system which requires an extremely high level of reliability, the failure or malfunction of which may result in a direct threat to human life or create a risk of human injury (such as a medical instruments, transportation equipment, aerospace machinery, nuclear reactor controllers, fuel controllers, or other safety device). ROHM shall bear no responsibility in any way for the use of any Products for the above special purposes. If a Product is to be used for any such special purpose, please contact a ROHM sales representative before purchasing.

If intending to export or ship overseas any Product or technology specified herein that is controlled under the Foreign Exchange and Foreign Trade Law it may be necessary to obtain a license or permit under the applicable law.



Thank you for your interest in ROHM products.
Please contact us for additional information or product catalogs.

ROHM Customer Support System

<http://www.rohm.com/contact/>

Mouser Electronics

Authorized Distributor

Click to View Pricing, Inventory, Delivery & Lifecycle Information:

[ROHM Semiconductor:](#)

[BD9C601EFJ-EVK-001](#)

Данный компонент на территории Российской Федерации

Вы можете приобрести в компании MosChip.

Для оперативного оформления запроса Вам необходимо перейти по данной ссылке:

<http://moschip.ru/get-element>

Вы можете разместить у нас заказ для любого Вашего проекта, будь то серийное производство или разработка единичного прибора.

В нашем ассортименте представлены ведущие мировые производители активных и пассивных электронных компонентов.

Нашей специализацией является поставка электронной компонентной базы двойного назначения, продукции таких производителей как XILINX, Intel (ex.ALTERA), Vicor, Microchip, Texas Instruments, Analog Devices, Mini-Circuits, Amphenol, Glenair.

Сотрудничество с глобальными дистрибьюторами электронных компонентов, предоставляет возможность заказывать и получать с международных складов практически любой перечень компонентов в оптимальные для Вас сроки.

На всех этапах разработки и производства наши партнеры могут получить квалифицированную поддержку опытных инженеров.

Система менеджмента качества компании отвечает требованиям в соответствии с ГОСТ Р ИСО 9001, ГОСТ РВ 0015-002 и ЭС РД 009

Офис по работе с юридическими лицами:

105318, г.Москва, ул.Щербаковская д.3, офис 1107, 1118, ДЦ «Щербаковский»

Телефон: +7 495 668-12-70 (многоканальный)

Факс: +7 495 668-12-70 (доб.304)

E-mail: info@moschip.ru

Skype отдела продаж:

moschip.ru

moschip.ru_4

moschip.ru_6

moschip.ru_9