

9 MILLION LIFE CYCLE

The HJFC Hall Effect Foot Pedal is built to perform under the worst possible conditions. The unique design places Hall effect sensors and electronics behind a solid plastic diaphragm that separates the top and bottom halves of the front pedal, sealing the electronics in an IP68S rated enclosure. The bottom half of the pedal utilizes the same proven contactless analog output Hall effect technology used in OTTO joysticks and is available in J1939 and CANopen[®] formats. The CAN interface provides three analog input channels, 12 digital input channels and two digital output channels. It will withstand operating temperature extremes of -40°C to +85°C, is sealed to IP68S immersion requirements and passes EMI/RFI immunity testing to 100V/M.

The HJFC Hall Effect Foot Pedal provides a life of nine million cycles. The pedal's pivot point itself is also sealed against large debris. Customer specified features such as pretravel (dead band) and overtravel, along with a minimum and maximum output, are programmable. The sensor programming is completed in automated fixtures during assembly ensuring tight output tolerances. The HJFC Hall Effect Foot Pedal offers more performance features and a higher cycle and seal rating than any other foot pedal on the market.

Features:

- Outstanding EMI/RFI immunity
- Heavy gauge, corrosion-resistant metal
- Proven contactless analog output Hall effect technology
- J1939, CANopen[®] formats available
- Life expectancy of 9 million cycles
- Hall sensors & electronics are sealed against the elements, behind a solid plastic diaphragm that separates the top & bottom halves of the foot pedal
- Electronics are sealed to IP68S
- Pedal pivot point sealed against large debris
- Programmable pretravel (dead band) & overtravel along with minimum & maximum output
- Sensor programming is completed in automated fixtures during assembly ensuring tight output tolerances
- Reverse polarity protection available
- RoHS/WEEE/Reach compliant

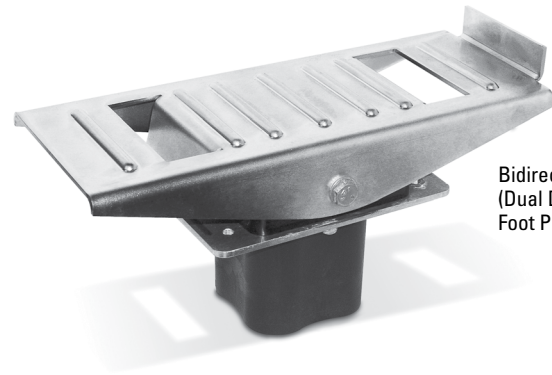

Bidirectional
(Dual Direction)
Foot Pedal

Standard Characteristics/Ratings:				
MECHANICAL:				
Mechanical Life:	9,000,000 cycles			
Vibration:	10g, 24Hz to 2KHz swept sinusoidal			
TRAVEL ANGLE:				
Degrees:	13° nominal dual direction, 15° nominal single direction			
Operating Force (lbs.):	14.0 lbs. typical -40°C to +85°C at load reference point			
Electrical Life:	9,000,000 cycles			
ELECTRICAL RATINGS:				
Electrical	Units	Min	Typ	Max
Supply Current Per Sensor	mA	N/A	N/A	10
Output Resistance (I _o ≤ -2mA)	Ω	N/A	100	N/A
Analog Supply Voltage (Option 1)	VDC	4.5	5	5.5
Analog Supply Voltage (Option 2)	VDC	8	12	18
Analog Output Voltage Tolerance at Center (see graph for output values) @ 5Vcc	VDC	-0.15	N/A	+0.15
Analog Output Voltage Tolerance at Full Travel (see graph for output values) @ 5Vcc	VDC	-0.15	N/A	+0.15
Limit Switch Supply Voltage (if applicable)	Volts	5	N/A	30
Limit Switch Actuation (if applicable)	Degrees	1°	2°	3°
Analog Output Pretravel	Degrees	1°	2°	3°
Analog Output Overtravel	Degrees	1°	2°	3°
<i>Note: Limit switch outputs will source limit switch supply voltage when actuated.</i>				
ELECTRONICS:				
Seal:	Electronics IP68S			
RFI:	Withstand per SAE J1113			
EMI:	Withstand per SAE J1113			
ENVIRONMENTAL:				
Operating Temp Range:	-40°C to +85°C			
Humidity:	96% RH, 70°C, 96 hours			
Sand/Dust:	Withstand per SAE J1455			
MATERIALS:				
Foot Pedal Plate:	Zinc and high corrosion trivalent chromate			
Housing:	PPE/PA			
Cable:	22 AWG (19 strands of 34 AWG TSC) PVC/Polyurethane blend outer jacket			
Mounting Hardware:	None provided			

HALL EFFECT FOOT PEDAL

SINGLE DIRECTION & DUAL DIRECTION

HJFC PART NUMBER CODE

HJFC		X	X	X	X	X	X	X
Direction	Travel	Output*			Sealing	Power	Termination	Pedal
1. Single	1. 15 Degrees	1. Single Direction Analog Output: (Rest/Full) 0.5/4.5VDC			1. Fully Sealed	1. Regulated 5VDC Clean Supply, No Reverse Polarity Protection	1. 0.225" Dia., 12" Cable, Untermated	1. Narrow Mounting**
2. Dual	2. 13 Degrees	2. Dual Direction Analog Output: (REV/CTR/FWD) 0.5/2.5/4.5VDC			2. Unsealed	2. 12VDC Power Supply with Reverse Polarity Protection		2. Wide Mounting
	Dual Direction	3. Dual Direction Analog Output: (REV/CTR/FWD) 0.5/2.5/4.5VDC & Dual Direction Position Indication				3. 24VDC Power Supply with Reverse Polarity Protection		
		4. Dual Direction Dual Analog Output 1: (CTR/FWD) 0.5/4.5VDC Output 2: (REV/CTR) 4.5/0.5VDC						
		5. Single Direction Analog Output: (Rest/Full) 0.5/4.5VDC & Single Direction Position Indication						
		6. Single Direction Dual Analog Output 1: (Rest/Full) 0.5/4.5VDC Output 2: (Rest/Full) 4.5/0.5VDC						
		7. Dual Direction Dual Analog Output 1: (REV/CTR/FWD) 0.5/2.5/4.5VDC Output 2: (REV/CTR/FWD) 0.5/2.5/4.5VDC						
		8. Dual Direction Dual Analog Output 1: (REV/CTR/FWD) 0.5/2.5/4.5 Output 2: (REV/CTR/FWD) 4.5/2.5/0.5						

* Additional configurations are available. Contact factory.
** Single direction not available in narrow mounting.

SINGLE DIRECTION WIDE MOUNTING

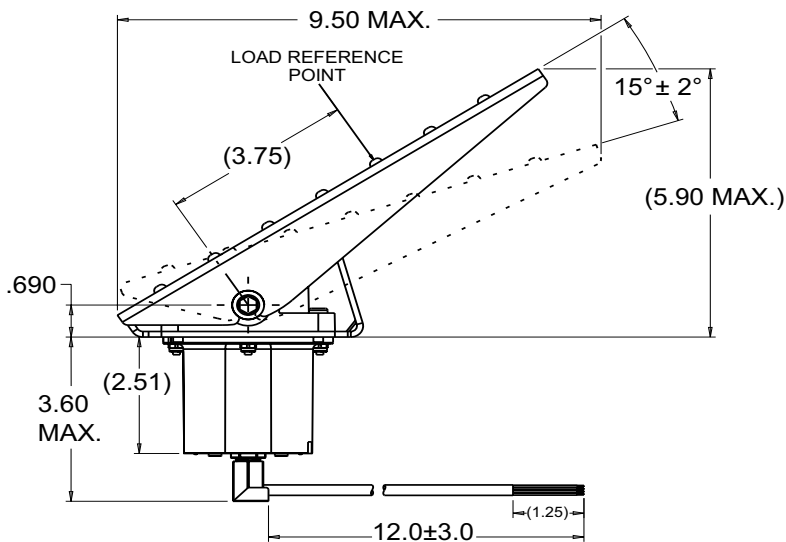
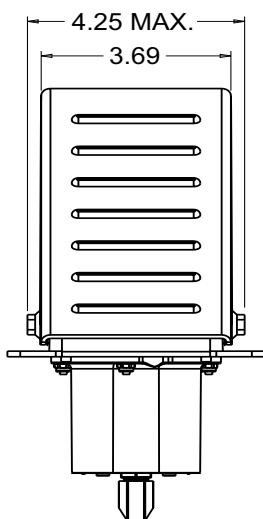
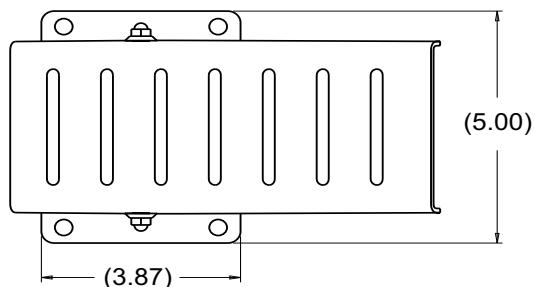
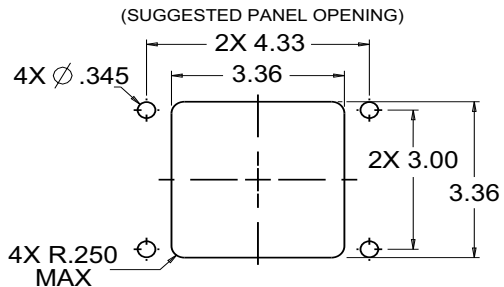

SINGLE DIRECTION & DUAL DIRECTION

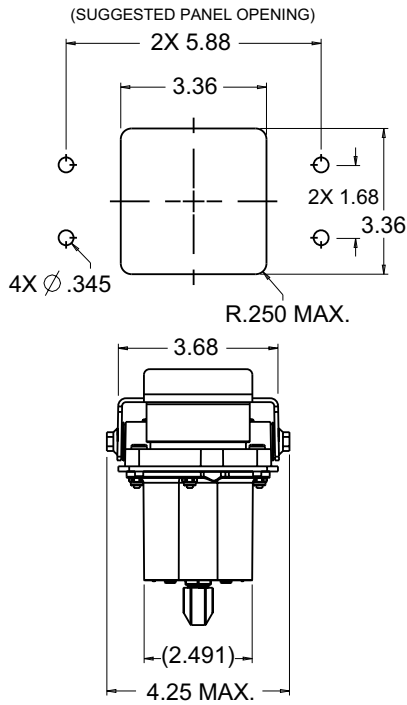

DUAL DIRECTION
(NARROW MOUNTING)

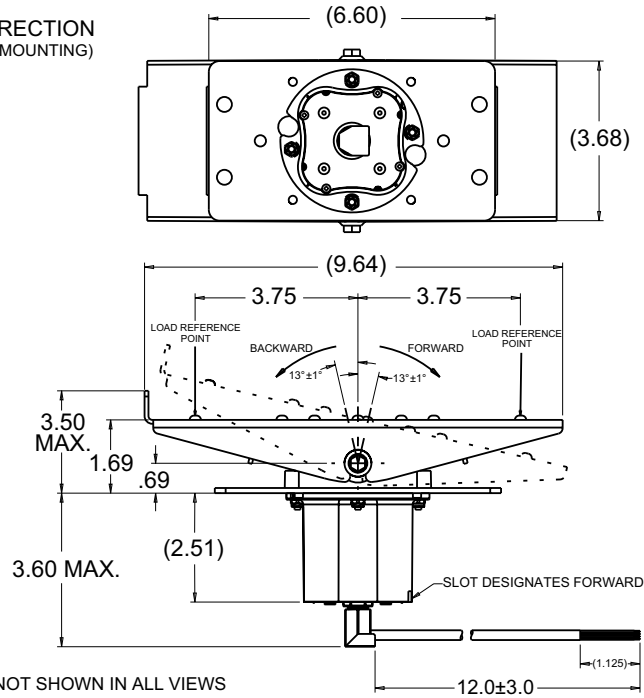

OUTPUT OPTIONS

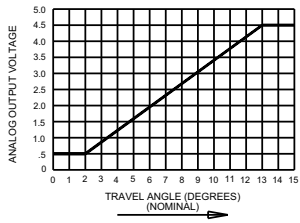

OPTION 1

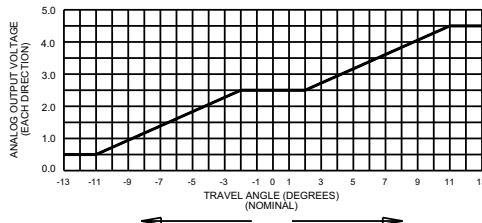

OPTION 2

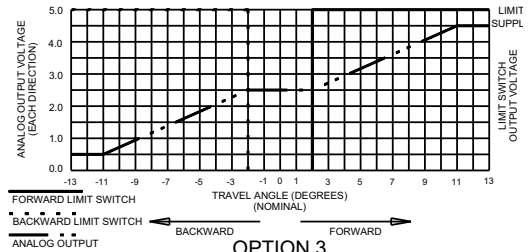

OPTION 3

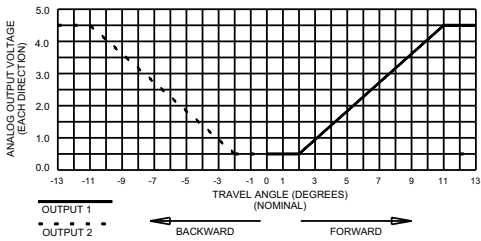

OPTION 4

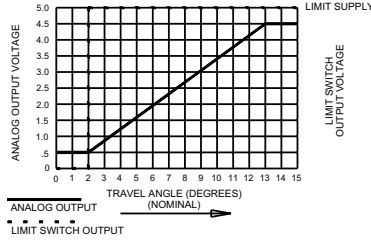

OPTION 5

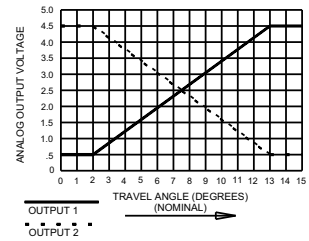

OPTION 6

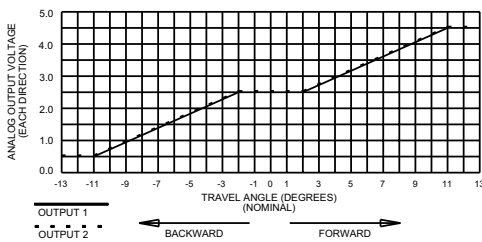

OPTION 7

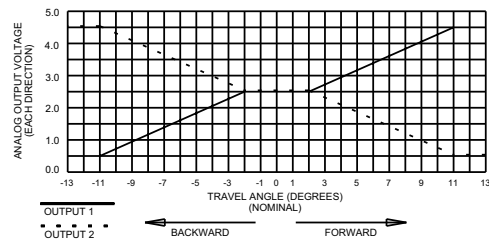

OPTION 8

Данный компонент на территории Российской Федерации

Вы можете приобрести в компании MosChip.

Для оперативного оформления запроса Вам необходимо перейти по данной ссылке:

<http://moschip.ru/get-element>

Вы можете разместить у нас заказ для любого Вашего проекта, будь то серийное производство или разработка единичного прибора.

В нашем ассортименте представлены ведущие мировые производители активных и пассивных электронных компонентов.

Нашей специализацией является поставка электронной компонентной базы двойного назначения, продукции таких производителей как XILINX, Intel (ex.ALTERA), Vicor, Microchip, Texas Instruments, Analog Devices, Mini-Circuits, Amphenol, Glenair.

Сотрудничество с глобальными дистрибьюторами электронных компонентов, предоставляет возможность заказывать и получать с международных складов практически любой перечень компонентов в оптимальные для Вас сроки.

На всех этапах разработки и производства наши партнеры могут получить квалифицированную поддержку опытных инженеров.

Система менеджмента качества компании отвечает требованиям в соответствии с ГОСТ Р ИСО 9001, ГОСТ РВ 0015-002 и ЭС РД 009

Офис по работе с юридическими лицами:

105318, г.Москва, ул.Щербаковская д.3, офис 1107, 1118, ДЦ «Щербаковский»

Телефон: +7 495 668-12-70 (многоканальный)

Факс: +7 495 668-12-70 (доб.304)

E-mail: info@moschip.ru

Skype отдела продаж:

moschip.ru

moschip.ru_4

moschip.ru_6

moschip.ru_9