

## Features

- Low Voltage Operation: 2.5 V
- Low Insertion Loss: 0.3 dB at 1 GHz
- Isolation: 34 dB @ 2.4 GHz
- 0.5 micron GaAs PHEMT Process
- Lead-Free 1.2 x 1.5 mm 6-Lead PQFN Package
- 100% Matte Tin Plating over Copper
- Halogen-Free "Green" Mold Compound
- RoHS Compliant\* and 260°C Reflow Compatible

## Description

M/A-COM's MASWSS0167 is a GaAs PHEMT MMIC single pole double throw (SPDT) switch in a lead-free 1.2 x 1.5 mm 6-lead PQFN package. The MASWSS0167 is ideally suited for applications where low control voltage, low insertion loss, moderate isolation, small size and low cost are required.

Typical applications are for filter and antenna switching in wireless LAN systems that connect separate receive functions to a common antenna, as well as other handset and general purpose switching applications.

The MASWSS0167 is fabricated using a 0.5 micron gate length GaAs PHEMT process. The process features full passivation for performance and reliability.

## Ordering Information<sup>1</sup>

Part Number	Package
MASWSS0167TR-3000	3000 piece reel
MASWSS0167SMB	Sample Test Board

1. Reference Application Note M513 for reel size information.

## Functional Schematic

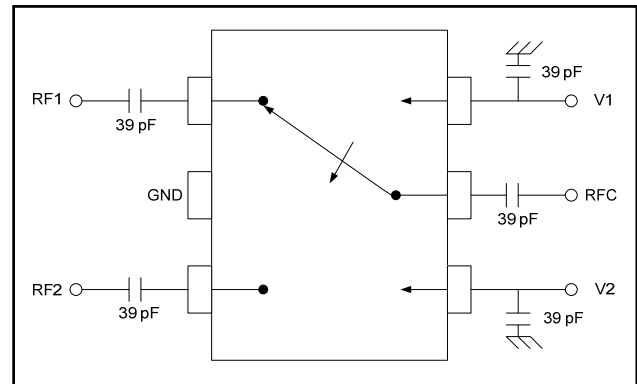

## Pin Configuration

Pin No.	Pin Name	Description
1	RF1	RF In/Out
2	GND	RF Ground
3	RF2	RF In/Out
4	V2	Control 2
5	RFC	RF Common
6	V1	Control 1

## Absolute Maximum Ratings<sup>2,3</sup>

Parameter	Absolute Maximum
Input Power (0.5 - 3 GHz, 2.5 V Control)	+32 dBm
Operating Voltage	+8.5 volts
Operating Temperature	-40°C to +85°C
Storage Temperature	-65°C to +150°C

2. Exceeding any one or combination of these limits may cause permanent damage to this device.
3. M/A-COM does not recommend sustained operation near these survivability limits.

\* Restrictions on Hazardous Substances, European Union Directive 2002/95/EC.

## 2.5 V GaAs SPDT Switch 0.5 - 3.0 GHz

Rev. V2

**Electrical Specifications:  $T_A = 25^\circ\text{C}$ ,  $V_C = 0\text{ V} / +2.5\text{ V}$ ,  $Z_0 = 50\ \Omega$  <sup>4</sup>**

Parameter	Test Conditions	Units	Min.	Typ.	Max.
Insertion Loss <sup>5</sup>	1 GHz	dB	—	0.30	0.50
	2 GHz	dB	—	0.40	—
	3 GHz	dB	—	0.50	—
Isolation	1 GHz	dB	23	25	—
	2 GHz	dB	—	27	—
	3 GHz	dB	—	24	—
VSWR	0.5 - 3.0 GHz	Ratio	—	1.1	—
IP3	Two Tone, +10 dBm/tone, 5 MHz Spacing, > 50 MHz	dBm	—	48	—
P1dB	—	dBm	—	28	—
Linear Pout	2.5 GHz, OFDM, QAM-64, 54Mbps, EVM=2.5%				
	2.5 V	dBm	—	21.0	—
	3.0 V	dBm	—	23.5	—
	5.0 V	dBm	—	28.5	—
Trise, Tfall	10% to 90% RF, 90% to 10% RF	nS	—	30	—
Ton, Toff	50% control to 90% RF, and 50% control to 10% RF	nS	—	35	—
Transients	In Band	mV	—	60	—
Control Current	$ V_C  = 2.5\text{ V}$	$\mu\text{A}$	—	1	5

4. For positive voltage control, external DC blocking capacitors are required on all RF ports.

5. Insertion Loss can be optimized by varying the DC blocking capacitor value, e.g. 1000 pF for 100 MHz - 500 MHz, 39 pF for 0.5 - 3 GHz.

### Truth Table <sup>6</sup>

V1	V2	RFC - RF1	RFC - RF2
0	1	On	Off
1	0	Off	On

6. 0 =  $0 \pm 0.2\text{ V}$ , 1 = 2.5 to 5 V

### Handling Procedures

Please observe the following precautions to avoid damage:

### Static Sensitivity

Gallium Arsenide Integrated Circuits are sensitive to electrostatic discharge (ESD) and can be damaged by static electricity. Proper ESD control techniques should be used when handling these devices.

## Typical Performance Curves

### Insertion Loss

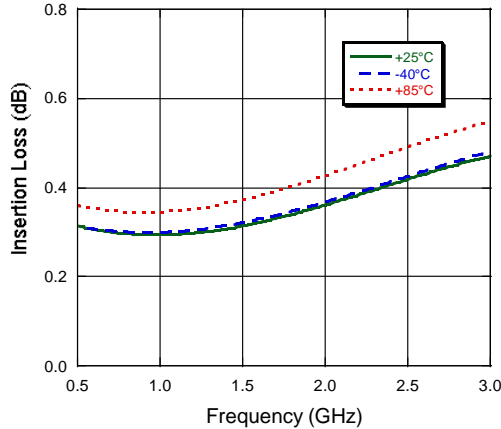

### Isolation

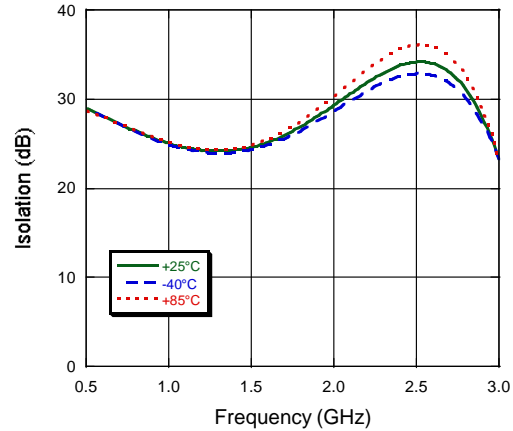

### Return Loss

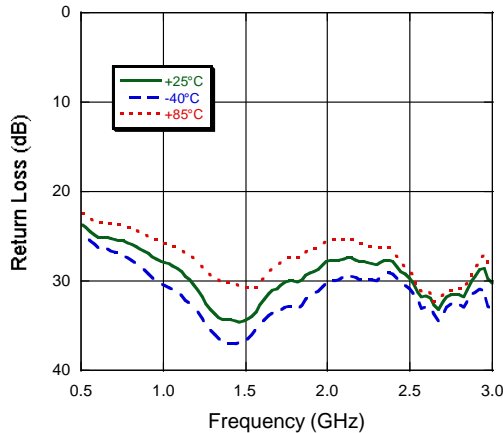

### EVM vs. Pout @ 2.5 GHz

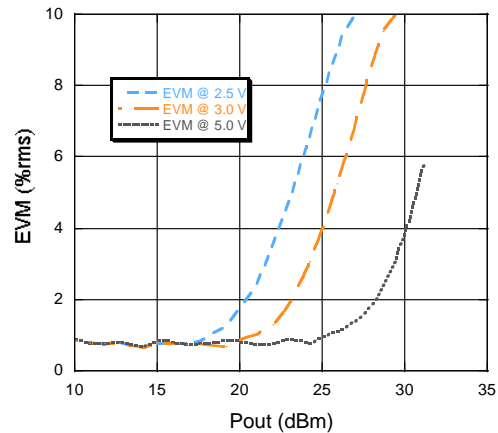

## Lead-Free 1.2 x 1.5 mm 6-Lead PQFN†

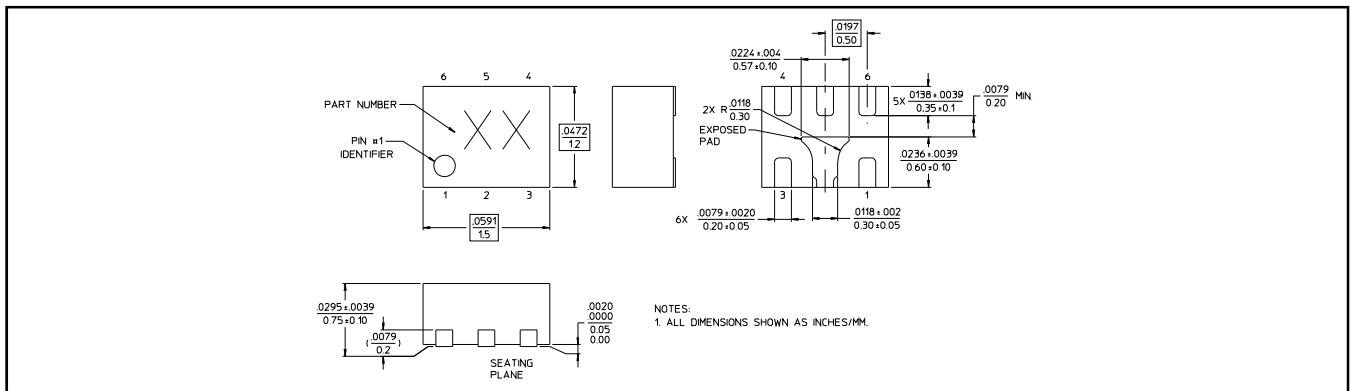

† Reference Application Note M538 for lead-free solder reflow recommendations.  
Meets JEDEC moisture sensitivity level 1 requirements.

**ADVANCED:** Data Sheets contain information regarding a product M/A-COM Technology Solutions is considering for development. Performance is based on target specifications, simulated results, and/or prototype measurements. Commitment to develop is not guaranteed.  
**PRELIMINARY:** Data Sheets contain information regarding a product M/A-COM Technology Solutions has under development. Performance is based on engineering tests. Specifications are typical. Mechanical outline has been fixed. Engineering samples and/or test data may be available. Commitment to produce in volume is not guaranteed.

- **North America** Tel: 800.366.2266 / Fax: 978.366.2266
- **Europe** Tel: 44.1908.574.200 / Fax: 44.1908.574.300
- **Asia/Pacific** Tel: 81.44.844.8296 / Fax: 81.44.844.8298

Visit [www.macomtech.com](http://www.macomtech.com) for additional data sheets and product information.

M/A-COM Technology Solutions Inc. and its affiliates reserve the right to make changes to the product(s) or information contained herein without notice.

## Данный компонент на территории Российской Федерации

### Вы можете приобрести в компании MosChip.

Для оперативного оформления запроса Вам необходимо перейти по данной ссылке:

<http://moschip.ru/get-element>

Вы можете разместить у нас заказ для любого Вашего проекта, будь то серийное производство или разработка единичного прибора.

В нашем ассортименте представлены ведущие мировые производители активных и пассивных электронных компонентов.

Нашей специализацией является поставка электронной компонентной базы двойного назначения, продукции таких производителей как XILINX, Intel (ex.ALTERA), Vicor, Microchip, Texas Instruments, Analog Devices, Mini-Circuits, Amphenol, Glenair.

Сотрудничество с глобальными дистрибьюторами электронных компонентов, предоставляет возможность заказывать и получать с международных складов практически любой перечень компонентов в оптимальные для Вас сроки.

На всех этапах разработки и производства наши партнеры могут получить квалифицированную поддержку опытных инженеров.

Система менеджмента качества компании отвечает требованиям в соответствии с ГОСТ Р ИСО 9001, ГОСТ РВ 0015-002 и ЭС РД 009

### Офис по работе с юридическими лицами:

105318, г.Москва, ул.Щербаковская д.3, офис 1107, 1118, ДЦ «Щербаковский»

Телефон: +7 495 668-12-70 (многоканальный)

Факс: +7 495 668-12-70 (доб.304)

E-mail: [info@moschip.ru](mailto:info@moschip.ru)

Skype отдела продаж:

moschip.ru

moschip.ru\_4

moschip.ru\_6

moschip.ru\_9