

# AS3935

## Franklin Lightning Sensor IC

### 1 General Description

The AS3935 is a programmable fully integrated Lightning Sensor IC that detects the presence and approach of potentially hazardous lightning activity in the vicinity and provides an estimation on the distance to the head of the storm. The embedded lightning algorithm checks the incoming signal pattern to reject the potential man-made disturbers.

The AS3935 can also provide information on the noise level and inform the external unit (e.g. microcontroller) in case of high noise conditions, with the noise floor generator and noise floor evaluation blocks.

The AS3935 can be programmed via a 4-wire standard SPI or an I<sup>2</sup>C. Also, in case the latter is chosen, it is possible to choose among four different addresses. Two clocks are internally generated by two different RC-Oscillators: TRCO and SRCO. An automatic procedure can increase the precision of those oscillators. The AS3935 can be either supplied by an internal voltage regulator or directly by VDD.

### 2 Key Features

- Lightning sensor warns of lightning storm activity within a radius of 40km

- Distance estimation to the head of the storm down to 1km in 14 steps
- Detects both cloud-to-ground and intra-cloud (cloud-to-cloud) flashes
- Embedded man-made disturber rejection algorithm
- Programmable detection levels enable threshold setting for optimal controls
- SPI and I<sup>2</sup>C interface is used for control and register reading
- Antenna Tuning to compensate variations of the external components
- Supply voltage range 2.4V to 5.5V
- Power-down, listening, and active mode
- Package: 16LD MLPQ (4x4mm)

### 3 Applications

AS3935 is ideal for Weather Stations, Clocks, Sports Equipment, Portables, Pool Safety, Uninterruptible Power Supply (UPS), Global Positioning System (GPS), Cellular phones, Watches, and Golf Equipment.

Figure 1. AS3935 Block Diagram

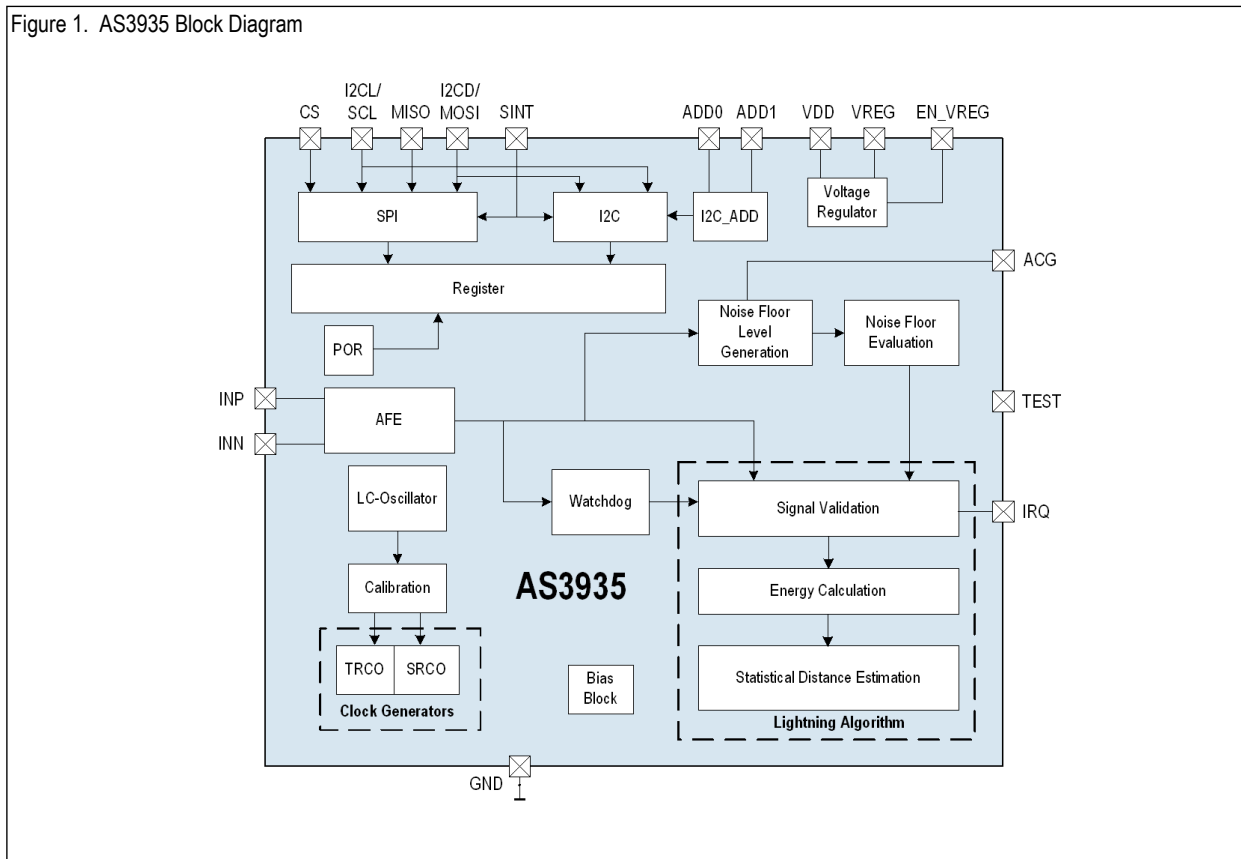

## Contents

1	General Description .....	1
2	Key Features.....	1
3	Applications.....	1
4	Pin Assignments .....	3
4.1	Pin Descriptions.....	3
5	Absolute Maximum Ratings .....	4
6	Electrical Characteristics.....	5
6.1	Operating Conditions.....	5
6.2	DC/AC Characteristics for Digital Inputs and Outputs .....	5
6.3	Detailed System and Block Specification .....	5
7	Typical Operating Characteristics .....	7
8	Detailed Description.....	8
8.1	Circuit .....	11
8.2	Operating Modes .....	11
8.3	System and Block Specification .....	11
8.3.1	Register Table .....	11
8.3.2	Register Table Description and Default Value .....	12
8.4	Serial Peripheral Interface (SPI).....	14
8.4.1	SPI Command Structure .....	14
8.4.2	Writing of Register Data.....	15
8.4.3	Reading of Data from Addressable Registers (READ Mode).....	15
8.4.4	Send Direct Command Byte .....	16
8.5	I <sup>2</sup> C.....	16
8.5.1	I <sup>2</sup> C Byte Write .....	17
8.5.2	I <sup>2</sup> C Register Read .....	18
8.5.3	Direct Command.....	18
8.6	Voltage Regulator .....	18
8.7	Analog Front-end (AFE) and Watchdog .....	19
8.8	Noise Floor Generator and Evaluation .....	20
8.9	Lightning Algorithm .....	20
8.9.1	Signal Validation .....	20
8.9.2	Energy Calculation.....	21
8.9.3	Statistical Distance Estimation.....	21
8.9.4	Interrupt Management .....	22
8.10	Antenna Tuning .....	23
8.11	Clock Generation .....	23
9	Package Drawings and Markings .....	24
10	Ordering Information.....	26

## 4 Pin Assignments

Figure 2. Pin Assignments (Top View)

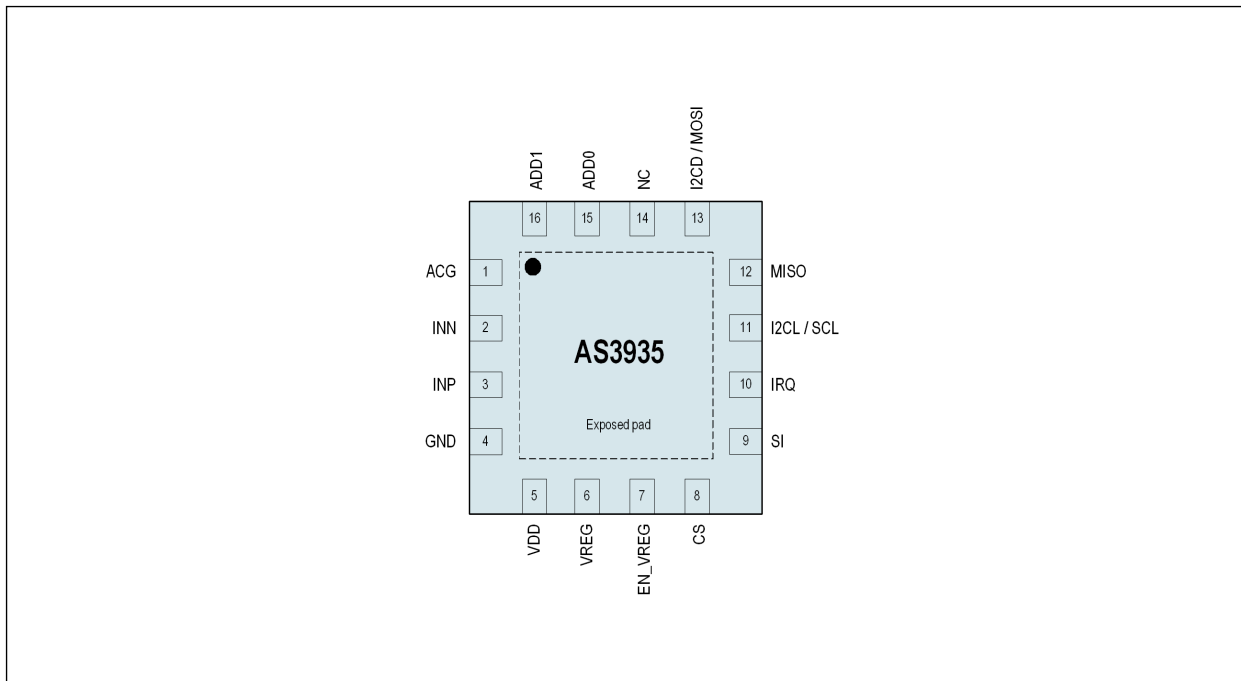

### 4.1 Pin Descriptions

Table 1. Pin Descriptions

Pin Number	Pin Name	Pin Type	Description
1	ACG	Analog I/O	AC-Ground
2	INN		Antenna ground
3	INP		Antenna positive input
4	GND	Supply pad	Ground
5	VDD		Positive supply voltage
6	VREG		Positive supply voltage / Regulated voltage
7	EN_VREG	Digital input	Voltage Regulator Enable
8	CS		Chip Select (active low)
9	SI		Select Interface (GND → SPI or VDD → I <sup>2</sup> C)
10	IRQ	Digital output	Interrupt
11	I2CL/SCL	Digital input	I <sup>2</sup> C clock bus or SPI clock bus (according to SI setting)
12	MISO	Digital output	SPI data output bus
13	I2CD/MOSI	Digital I/O with pull-up / Digital input	I <sup>2</sup> C data bus or SPI data input bus (according to SI setting)
14	NC		Not connected
15	ADD0	Digital input	I <sup>2</sup> C address selection LSB
16	ADD1		I <sup>2</sup> C address selection MSB
Exposed pad		Supply pad	Connect to Ground via the GND plain and pin 4

## 5 Absolute Maximum Ratings

Stresses beyond those listed in Table 2 may cause permanent damage to the device. These are stress ratings only, and functional operation of the device at these or any other conditions beyond those indicated in Electrical Characteristics on page 5 is not implied. Exposure to absolute maximum rating conditions for extended periods may affect device reliability.

Table 2. Absolute Maximum Ratings

Parameter	Min	Max	Units	Comments
Electrical Parameters				
DC supply voltage (V <sub>DD</sub> )	-0.5	7	V	
Input pin voltage (V <sub>IN</sub> )	-0.5	5	V	
Input current (latch up immunity), (I <sub>scr</sub> )	-100	100	mA	Norm: Jecdec 78
Electrostatic Discharge				
Electrostatic discharge (ESD)	±2		kV	Norm: MIL 883 E method 3015 (Human Body Model)
Continuous Power Dissipation				
Total power dissipation (all supplies and outputs), (P <sub>t</sub> )		0.1	mW	
Temperature Ranges and Storage Conditions				
Storage temperature (T <sub>strg</sub> )	-65	150	°C	
Package body temperature (T <sub>body</sub> )		260	°C	Norm: IPC/JEDEC J-STD-020 The reflow peak soldering temperature (body temperature) is specified according IPC/JEDEC J-STD-020 "Moisture/Reflow Sensitivity Classification for Non-hermetic Solid State Surface Mount Devices".
Humidity non-condensing	5	85	%	
Moisture Sensitivity Level (MSL)		3		Represents a maximum floor life time of 168h

## 6 Electrical Characteristics

### 6.1 Operating Conditions

In this specification, all the defined tolerances for external components need to be assured over the whole operation conditions range and also over lifetime.

Table 3. Operating Conditions

Symbol	Parameter	Conditions	Min	Typ	Max	Units
VDD	Positive supply voltage	In case the voltage regulator is ON	2.4		5.5	V
		In case the voltage regulator is OFF	2.4		3.6	V
TAMB	Ambient temperature		-40		85	°C

### 6.2 DC/AC Characteristics for Digital Inputs and Outputs

Table 4. CMOS Input

Symbol	Parameter	Conditions	Min	Typ	Max	Units
V <sub>IH</sub>	High level input voltage		0.6*VDD	0.7*VDD	0.9*VDD	V
V <sub>IL</sub>	Low level input voltage		0.125*VDD	0.2*VDD	0.3*VDD	V

**Note:** On ALL outputs, use the cells with the smallest drive capability which will do the job, in order to prevent current/spikes problems.

Table 5. CMOS Output

Symbol	Parameter	Conditions	Min	Typ	Max	Units
V <sub>OH</sub>	High level output voltage	With a load current of 1mA	VDD-0.4			V
V <sub>OL</sub>	Low level output voltage					
CL	Capacitive load	For a clock frequency of 1MHz			400	pF

Table 6. Tristate CMOS Output

Symbol	Parameter	Conditions	Min	Typ	Max	Units
V <sub>OH</sub>	High level output voltage	With a load current of 1mA	VDD-0.4			V
V <sub>OL</sub>	Low level output voltage					
I <sub>OZ</sub>	Tristate leakage current	To VDD and VSS			400	nA

### 6.3 Detailed System and Block Specification

Table 7. Electrical System Specifications

Symbol	Parameter	Min	Typ	Max	Units	Note
Input Characteristic						
R <sub>IN</sub>	Input AC impedance		200		kΩ	
Current Consumption						
I <sub>PWDROFF</sub>	Power-down current when VREG is OFF		1	2	μA	
I <sub>PWDRON</sub>	Power-down current when VREG is ON		8	15	μA	
I <sub>LSMROFF</sub>	Current consumption in listening mode when VREG is OFF		60	80	μA	
I <sub>LSMRON</sub>	Current consumption in listening mode when VREG is ON		70		μA	
I <sub>SVM</sub>	Current Consumption in signal verification mode		350		μA	

Table 7. Electrical System Specifications

Symbol	Parameter	Min	Typ	Max	Units	Note
LCOSUT	LCO Start-up Time			2	ms	Time needed by the LCO to start-up
T <sub>SRCO</sub>	SRCO frequency after calibration	1.065	1.125	1.19	MHz	Assuming FLCO = 500 kHz
T <sub>TRCO</sub>	TRCO frequency after calibration	30.5	32.26	34.0	kHz	
TRCOCAL	Calibration time for the RC oscillators			2	ms	The calibration of the RC oscillators starts after the LCO settles
VR <sub>OUT</sub>	Voltage regulator output voltage	2.7	3.0	3.3	V	

## 7 Typical Operating Characteristics

Figure 3. Power-down current if Voltage Regulator is OFF over Supply Voltage (VREG)

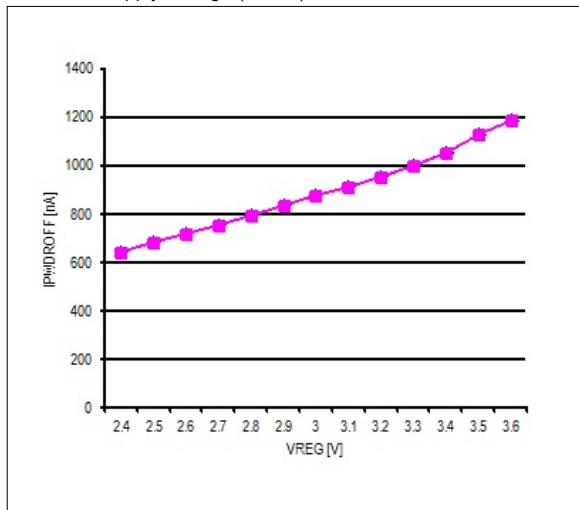

Figure 4. Power-down Current if Voltage Regulator is OFF @3V over Temperature

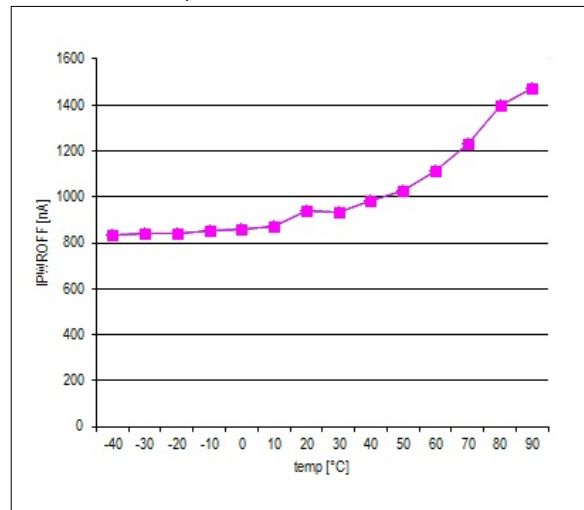

Figure 5. Current Consumption in Listening Mode if Voltage Regulator is OFF over Supply Voltage (VREG)

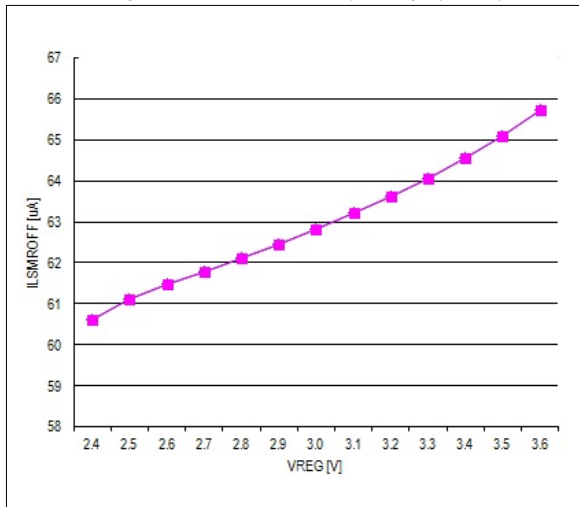

Figure 6. Current Consumption in Listening Mode if Voltage Regulator is OFF over Temperature (@ VREG=3V)

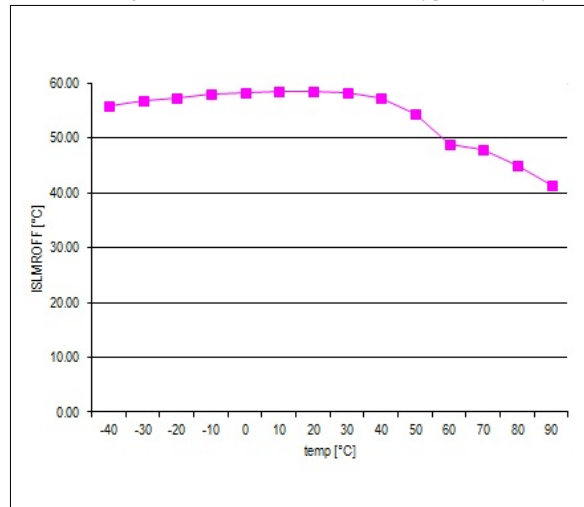

Figure 7. Output Regulated Voltage (VREG) @VDD=5V over Temperature

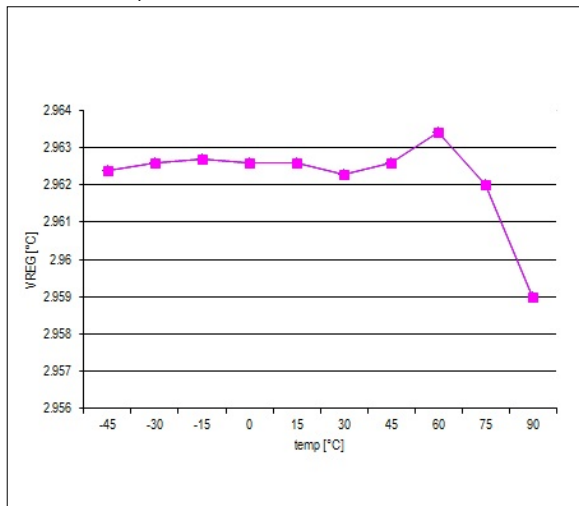
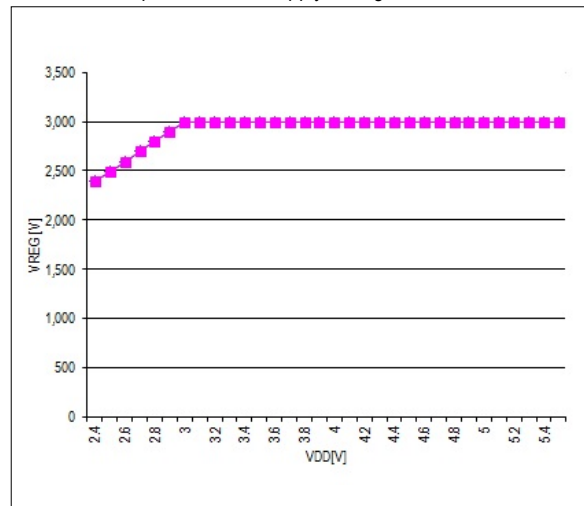

Figure 8. Output Regulated Voltage (VREG) @ Room Temperature over Supply Voltage



## 8 Detailed Description

The AS3935 can detect the presence of an approaching storm with lightning activities and provide an estimation of the distance to the leading edge of the storm, where the leading edge of the storm is defined as the minimum distance from the sensor to the closest edge of the storm. The embedded hardwired distance estimation algorithm of the AS3935 issues an interrupt on the IRQ pin (see [Interrupt Management on page 22](#)) every time a lightning is detected. The estimated distance which is displayed in the distance estimation register does not represent the distance to the single lightning but the estimated distance to the leading edge of the storm. A graphical representation is shown in the [Figure 9](#).

Figure 9. Storm

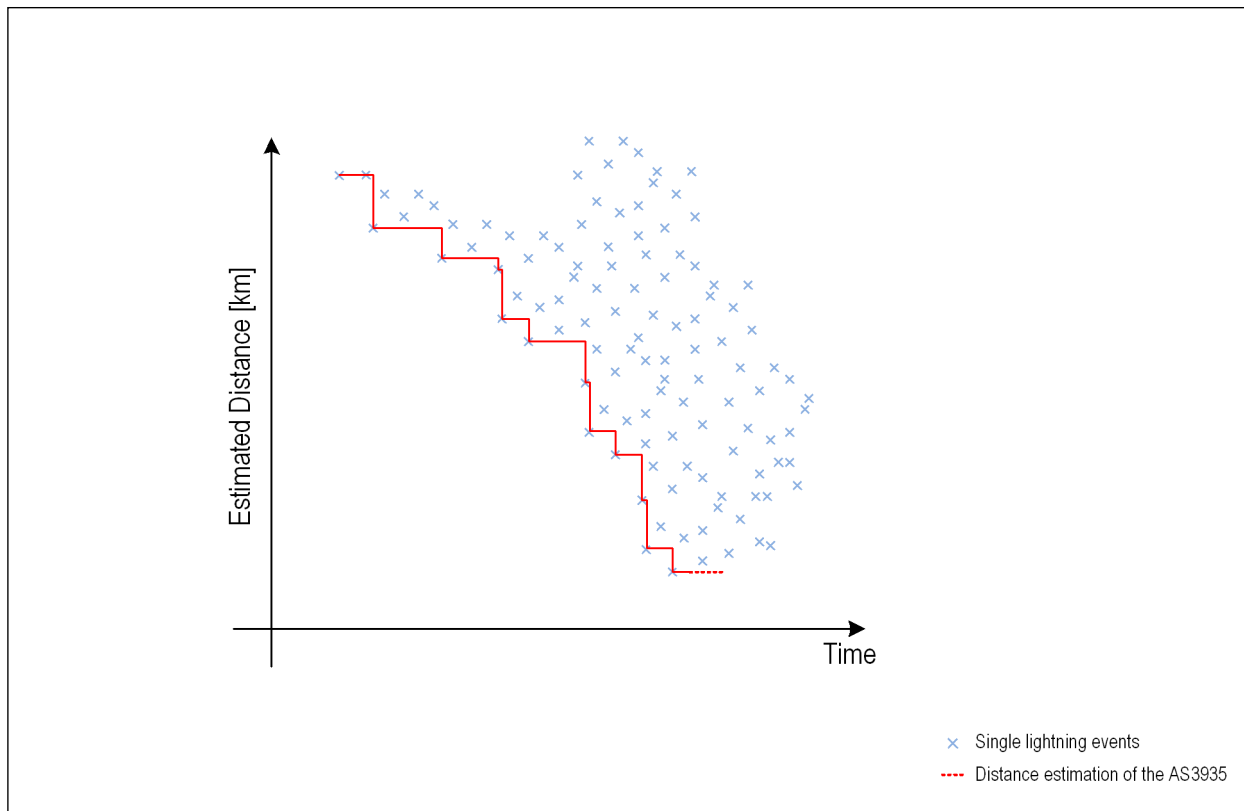

As shown in [Figure 10](#), [Figure 11](#), [Figure 12](#), and [Figure 13](#), the system integration consists mainly of the AS3935 and an external control unit (e.g. MCU) for the IC initialization and interrupt management (IRQ).

The choice of interface type (SPI vs. I<sup>2</sup>C) is accomplished using pin 9, SI (Select Interface). When the SI is connected to GND, the SPI is selected. When the SI is connected to VDD, the I<sup>2</sup>C is selected. Pins ADD0 and ADD1 are used to select among 4 different I<sup>2</sup>C address.

The internal voltage regulator can be enabled by connecting EN\_VREG to VDD. If the internal regulator is not used, capacitor C3 is not needed and VREG must be connected to VDD. In this case, the AS3935 can be directly supplied by VREG and VDD (EN\_VREG to GND).

AS3935 needs the following external components:

- Power supply capacitor – CBAT – 1 $\mu$ F
- Load capacitor on the ACG and VREG pins; the latter is needed only in case the voltage regulator is enabled
- One, RLC resonators for the antenna
- One resistor on the I2CL pin to VDD, if I<sup>2</sup>C is active ( $R2 > 10k\Omega$ )



Figure 10. AS3935 Application Diagram (Voltage Regulator OFF, SPI Active)

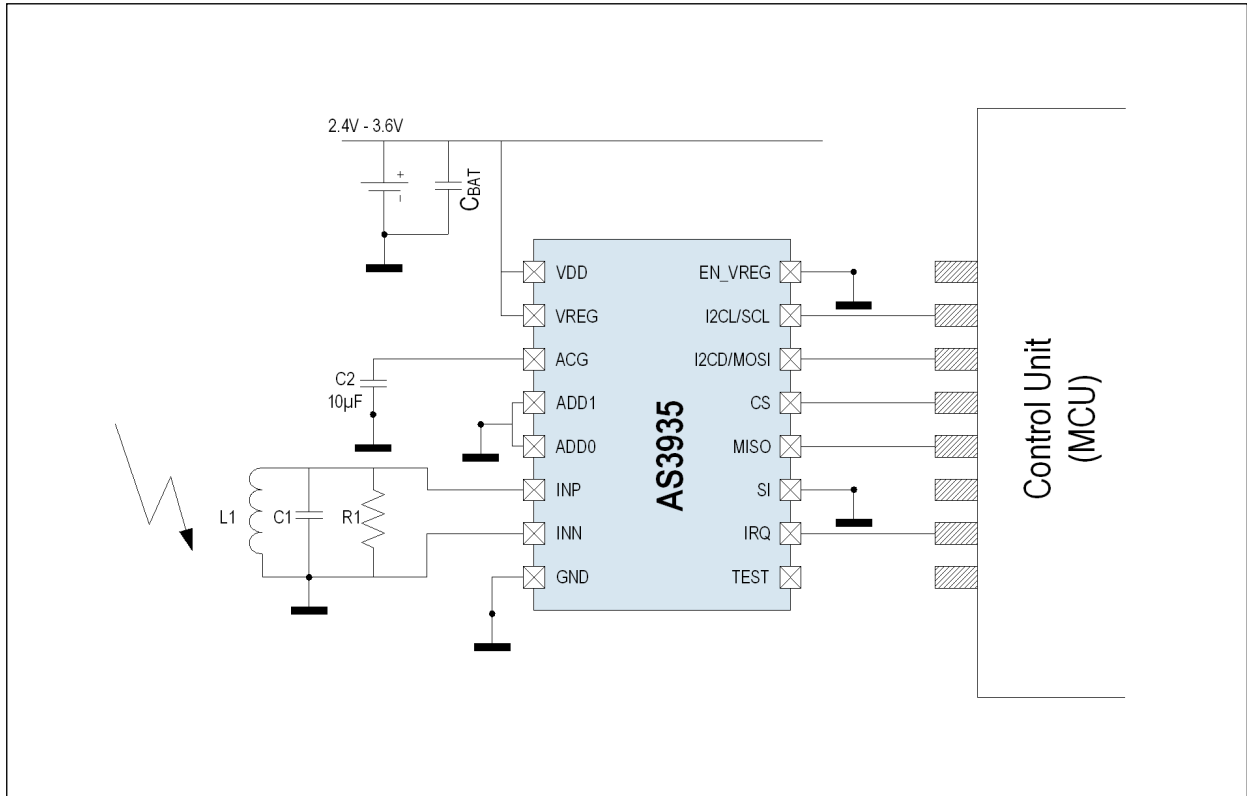

Figure 11. AS3935 Application Diagram (Voltage Regulator OFF, I<sup>2</sup>C Active)

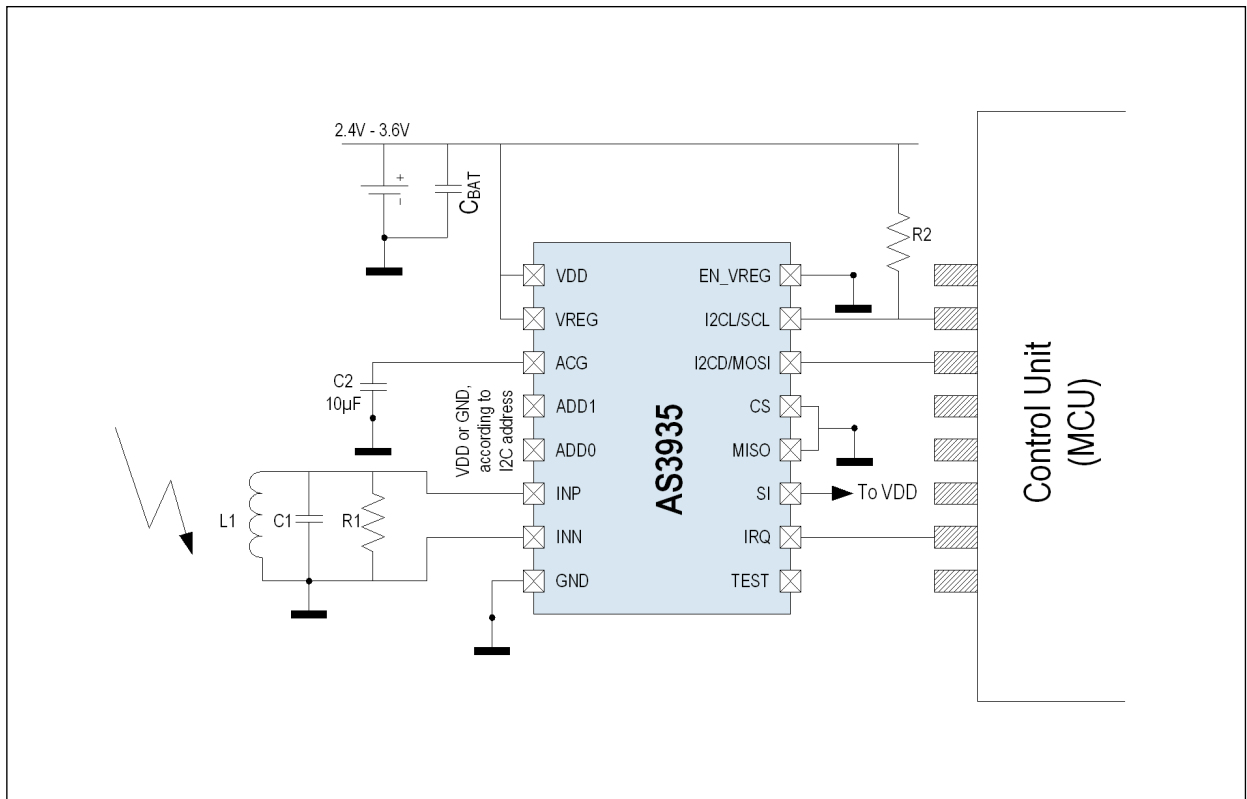

Figure 12. AS3935 Application Diagram (Voltage Regulator ON, SPI Active)

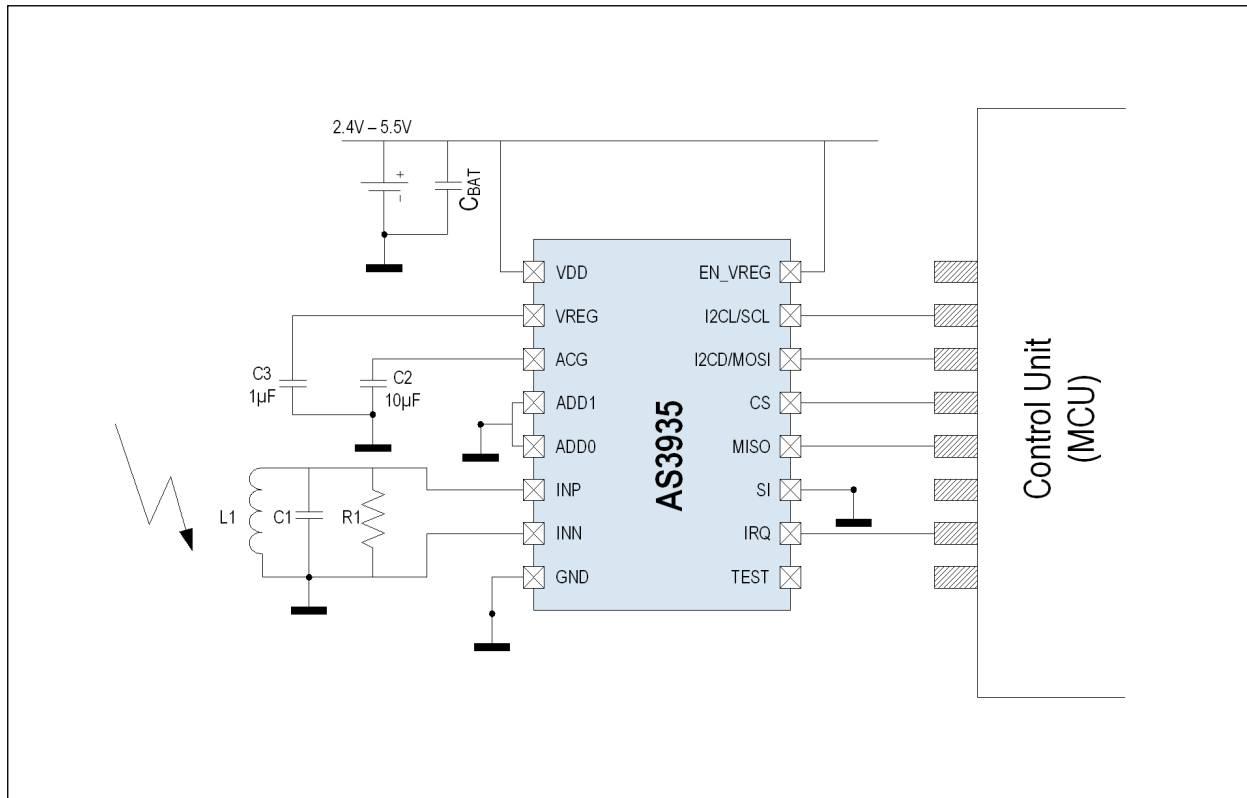
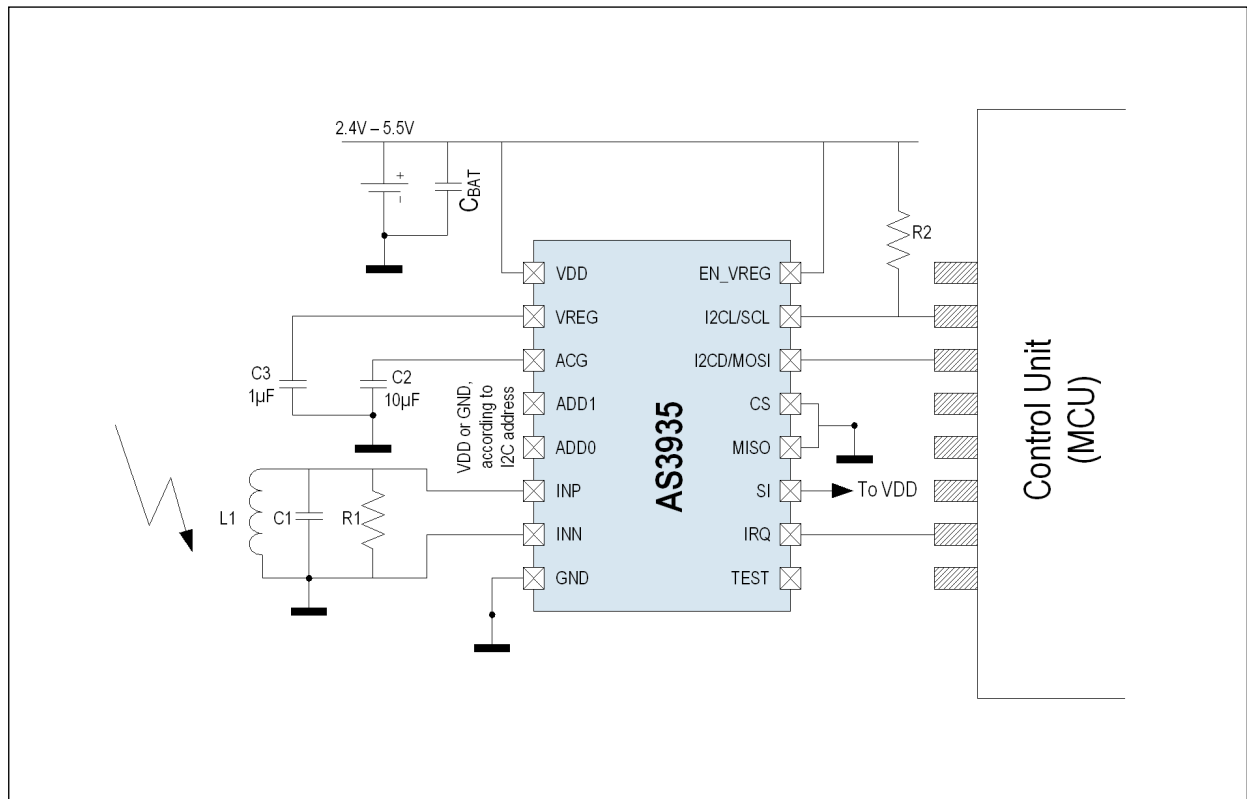

Figure 13. AS3935 Application Diagram (Voltage Regulator ON, I<sup>2</sup>C Active)



## 8.1 Circuit

Figure 1 shows a block diagram of the AS3935. The external antenna is directly connected to the Analog Front-end (AFE), which amplifies and demodulates the received signal. The watchdog continuously monitors the output of the AFE and alerts the integrated lightning algorithm block in the event of an incoming signal. The lightning algorithm block validates the signal by checking the incoming signal pattern, calculates the energy and then the AS3935 provides the MCU with an estimate of the distance to the head of the storm. The lightning algorithm block, processing the demodulated signal, can distinguish between lightning signal and man-made disturbers. If the received signal is classified as a man-made disturber, then the event is rejected and the system automatically goes back into listening mode to minimize current consumption. If the incoming signal identifies a lightning event, then the statistical distance estimation block performs an estimation of the distance to the head of the storm (Typical time needed 2ms).

The LC oscillator together with the calibration block can calibrate both the TRCO and the SRCO clock generator to compensate process variations.

## 8.2 Operating Modes

### Power-down Mode.

In Power-down Mode, the entire AS3935 is switched off to reduce the current consumption to minimum (typ 1 $\mu$ A).

### Listening Mode.

In listening mode the AFE, the watchdog, the noise floor level generation, the bias block, the TRCO, and the voltage regulator (in case it is enabled) are running. In this mode the system can push down the power consumption to a minimum (typ 60 $\mu$ A). In case the maximum voltage supply does not exceed 3.6V, it is possible to switch off the voltage regulator to save power.

### Signal Verification.

The AS3935 enters in this mode every time the watchdog detects dynamic activity picked up by the antenna. Threshold can be set in WDTN REG0x01[3:0]. The IC will leave this mode either if the incoming signal is classified as disturber or if the analysis of the single event (lightning) is finished. If the received signal is classified as a disturber, then the AS3935 will automatically go back to listening mode without any needed action from outside and an interrupt will be generated (with option bit this interrupt can be masked). If the received pattern matches all requirements, the energy calculation is performed and the AS3935 provides distance estimation.

## 8.3 System and Block Specification

### 8.3.1 Register Table

Table 8. Register Table

Register #	7	6	5	4	3	2	1	0
0x00	Reserved		AFE_GB					PWD
0x01	Reserved	NF_LEV			WDTH			
0x02	Reserved	CL_STAT	MIN_NUM_LIGH		SREJ			
0x03	LCO_FDIV		MASK_DIST	Reserved	INT			
0x04	S_LIG_L							
0x05	S_LIG_M							
0x06	Reserved			S_LIG_MM				
0x07	Reserved		DISTANCE					
0x08	DISP_LCO	DISP_SRCO	DISP_TRCO	Reserved	TUN_CAP			
0x09	Lightning Detection Look-up Table							
...								
...								
...								
...								
0x32								

## 8.3.2 Register Table Description and Default Value

Table 9. Detailed Register Map

Address	Register Name	Bit	Type	Default Value	Description
0x00	Reserved	[7:6]	R/W	0	reserved
	AFE_GB	[5:1]		10010	AFE Gain Boost
	PWD	[0]		0	Power-down
0x01	NF_LEV	[6:4]	R/W	010	Noise Floor Level
	WDTH	[3:0]		0001	Watchdog threshold
0x02	Reserved	[7]	R/W	1	reserved
	CL_STAT	[6]		1	Clear statistics
	MIN_NUM_LIGH	[5:4]		00	Minimum number of lightning
	SREJ	[3:0]		0010	Spike rejection
0x03	LCO_FDIV	[7:6]	R/W	00	Frequency division ration for antenna tuning
	MASK_DIST	[5]		0	Mask Disturber
	Reserved	[4]		0	reserved
	INT	[3:0]	R	0000	Interrupt (see Table 18)
0x04	S_LIG_L	[7:0]	R	00000000	Energy of the Single Lightning LSBYTE
0x05	S_LIG_M	[7:0]	R	00000000	Energy of the Single Lightning MSBYTE
0x06	Reserved	[7:5]	R	00000	reserved
	S_LIG_MM	[4:0]			Energy of the Single Lightning MMSBYTE
0x07	Reserved	[7:6]	R	000000	reserved
	DISTANCE	[5:0]			Distance estimation
0x08	DISP_LCO	[7]	R/W	0	Display LCO on IRQ pin
	DISP_SRCO	[6]		0	Display SRCO on IRQ pin
	DISP_TRCO	[5]		0	Display TRCO on IRQ pin
	TUN_CAP	[3:0]		0000	Internal Tuning Capacitors (from 0 to 120pF in steps of 8pf)
0x09	LDLUT1	[7:0]	R/W	10101101	Lightning Detection Look-up table
0x0A	LDLUT2	[7:0]	R/W	00000000	
0x0B	LDLUT3	[7:0]	R/W	00100101	
0x0C	LDLUT4	[7:0]	R/W	00000011	
0x0D	LDLUT5	[7:0]	R/W	00000001	
0x0E	LDLUT6	[7:0]	R/W	00100010	
0x0F	LDLUT7	[7:0]	R/W	10000011	
0x10	LDLUT8	[7:0]	R/W	00000001	
0x11	LDLUT9	[7:0]	R/W	00011111	
0x12	LDLUT10	[7:0]	R/W	01000011	
0x13	LDLUT11	[7:0]	R/W	00000010	
0x14	LDLUT12	[7:0]	R/W	00011011	
0x15	LDLUT13	[7:0]	R/W	01100011	

Table 9. Detailed Register Map

Address	Register Name	Bit	Type	Default Value	Description
0x16	LDLUT14	[7:0]	R/W	00000011	Lightning Detection Look-up table
0x17	LDLUT15	[7:0]	R/W	00011000	
0x18	LDLUT16	[7:0]	R/W	00010100	
0x19	LDLUT17	[7:0]	R/W	00000101	
0x1A	LDLUT18	[7:0]	R/W	00010100	
0x1B	LDLUT19	[7:0]	R/W	10011101	
0x1C	LDLUT20	[7:0]	R/W	00000111	
0x1D	LDLUT21	[7:0]	R/W	00010001	
0x1E	LDLUT22	[7:0]	R/W	01101010	
0x1F	LDLUT23	[7:0]	R/W	00001011	
0x20	LDLUT24	[7:0]	R/W	00001110	
0x21	LDLUT25	[7:0]	R/W	00011101	
0x22	LDLUT26	[7:0]	R/W	00010001	
0x23	LDLUT27	[7:0]	R/W	00001100	
0x24	LDLUT28	[7:0]	R/W	10101011	
0x25	LDLUT29	[7:0]	R/W	00011001	
0x26	LDLUT30	[7:0]	R/W	00001010	
0x27	LDLUT31	[7:0]	R/W	01111111	
0x28	LDLUT32	[7:0]	R/W	00100110	
0x29	LDLUT33	[7:0]	R/W	00001000	
0x2A	LDLUT34	[7:0]	R/W	10111101	
0x2B	LDLUT35	[7:0]	R/W	00111001	
0x2C	LDLUT36	[7:0]	R/W	00000110	
0x2D	LDLUT37	[7:0]	R/W	10011011	
0x2E	LDLUT38	[7:0]	R/W	01010110	
0x2F	LDLUT39	[7:0]	R/W	00000101	
0x30	LDLUT40	[7:0]	R/W	11100111	
0x31	LDLUT41	[7:0]	R/W	10000001	
0x32	LDLUT42	[7:0]	R/W	00000001	

## 8.4 Serial Peripheral Interface (SPI)

This 4-wire standard SPI interface (Mode 1) can be used by the Microcontroller ( $\mu\text{C}$ ) to program the AS3935. To enable the SPI as data interface, the Select Interface (SI) has to be set to low (GND).

The maximum clock operation frequency of the SPI is 2MHz.

**Note:** The clock operation frequency of the SPI should NOT be identical to the resonance frequency of the antenna (500kHz), in order to minimize the on board 500kHz noise.

Table 10. Serial Data Interface (SDI) Pins

Name	Signal	Signal Level	Description
CS	Digital Input	CMOS	Chip Select (Active Low)
MOSI	Digital Input	CMOS	Serial data input from the external unit to the AS3935
MISO	Digital Output	CMOS	Serial data output from the AS3935 to the external unit
SCLK	Digital Input	CMOS	Clock for serial data read and write

**Note:** MISO is set to tristate if CS is high. In this way more than one device can communicate on the same MISO bus.

### 8.4.1 SPI Command Structure

To activate this SPI, the CS has to be set to low. A SPI command consists of two bytes serial command and the data are sampled on the falling edge of SCLK (CPHA=1). The next table shows command structure, from the MSB (B15) to LSB (B0). The command stream has to be sent to the SPI from the MSB (B15) to the LSB (B0).

MODE		Register Address / Direct Command						Register Data							
B15	B14	B13	B12	B11	B10	B9	B8	B7	B6	B5	B4	B3	B2	B1	B0

The first two bits (B15 and B14) define the operating mode. There are two modes available – Read and Write/Direct command.

Table 11. Bits B15, B14

B15	B14	Mode
0	0	WRITE / DIRECT COMMAND
0	1	READ

In case a write or read command happens, then the next 5 bits (B13 to B9) define the register address, which has to be written respectively read, as shown in the table below. The direct command is performed with a write operation (see [Send Direct Command Byte on page 16](#)).

Table 12. Bits B13 to B9

B13	B12	B11	B10	B9	B8	Read / Write Register
0	0	0	0	0	0	0x00
0	0	0	0	0	1	0x01
0	0	0	0	1	0	0x02
0	0	0	0	1	1	0x03
0	0	0	1	0	0	0x04
0	0	0	1	0	1	0x05
0	0	0	1	1	0	0x06
0	0	0	1	1	1	0x07
...	...	...	...	...	...	...
...	...	...	...	...	...	...
1	1	0	0	0	1	0x31
1	1	0	0	1	0	0x32

### 8.4.2 Writing of Register Data

Figure 14. SPI Page Write

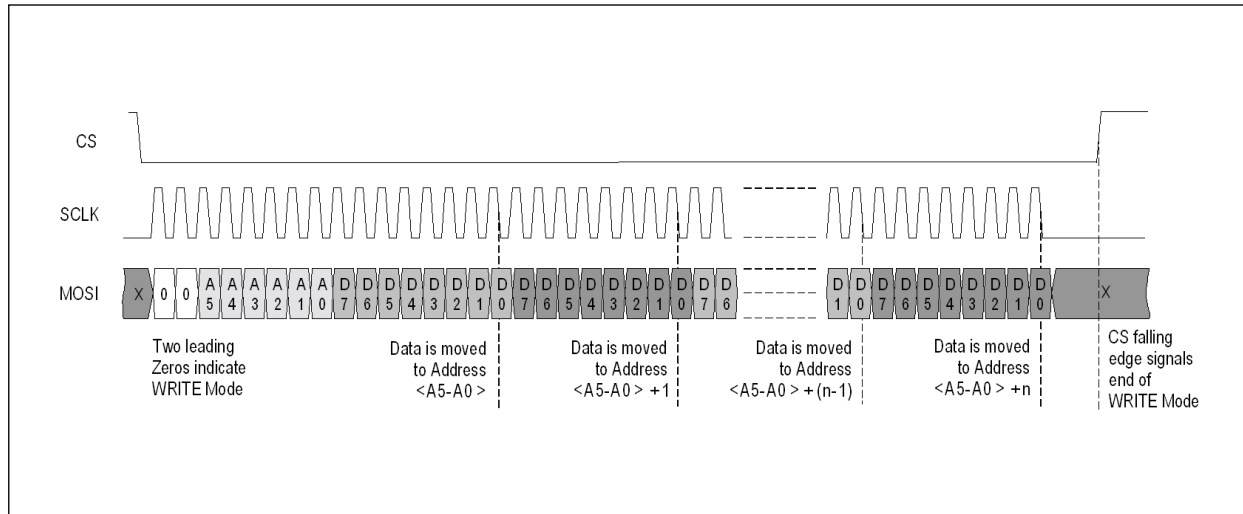

### 8.4.3 Reading of Data from Addressable Registers (READ Mode)

Once the address has been sent via SPI, the data can be fed through the MISO pin out to the microcontroller.

A CS high toggling high-low-high has to be performed after finishing the read mode session, in order to indicate the end of the READ command and prepare the Interface to the next command control Byte.

To transfer bytes from consecutive addresses, SPI master has to keep the CS signal low and the SCLK clock has to be active as long as data need to be read.

Figure 15. SPI Read Byte

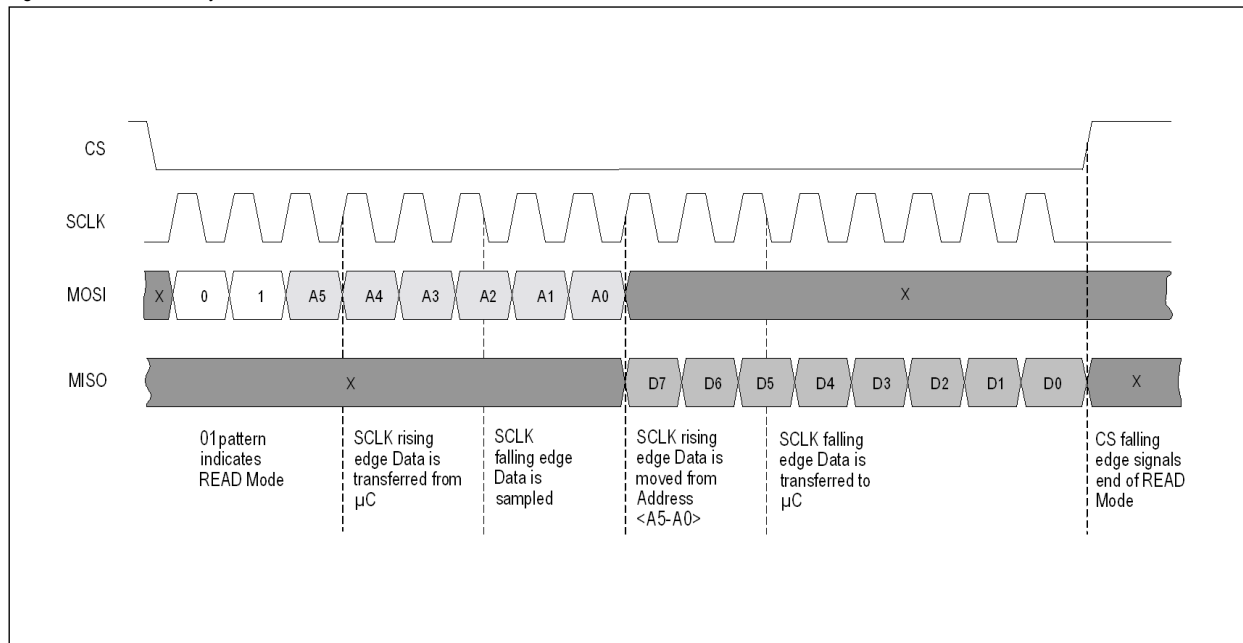

### 8.4.4 Send Direct Command Byte

It is possible to send direct commands by writing 0x96 in the registers REG0x3C and REG0x3D, as shown in the table below:

Table 13. Registers 0x3C, 0x3D

Direct Command	Register	Description
PRESET_DEFAULT	0x3C	Sets all registers in default mode
CALIB_RCO	0x3D	Calibrates automatically the internal RC Oscillators

## 8.5 I<sup>2</sup>C

An I<sup>2</sup>C slave interface is implemented for read/write access to the internal registers and to send direct commands. To enable the I<sup>2</sup>C as interface, the Select Interface pin has to be set to the positive voltage supply (SI=VDD). The I2CL is the clock bus, while the I2CD is the data bus. An external pull-up resistor on the I2CL pin is needed.

The device addresses for the AS3935 in read or write mode are defined by:

0-0-0-0-0-a1-a0-0: write mode device address (DW)

0-0-0-0-0-a1-a0-1: read mode device address (DR)

Where a0 and a1 are defined by the pins 5 (ADD0) and 6 (ADD1).

Figure 16. I<sup>2</sup>C Timing Diagram

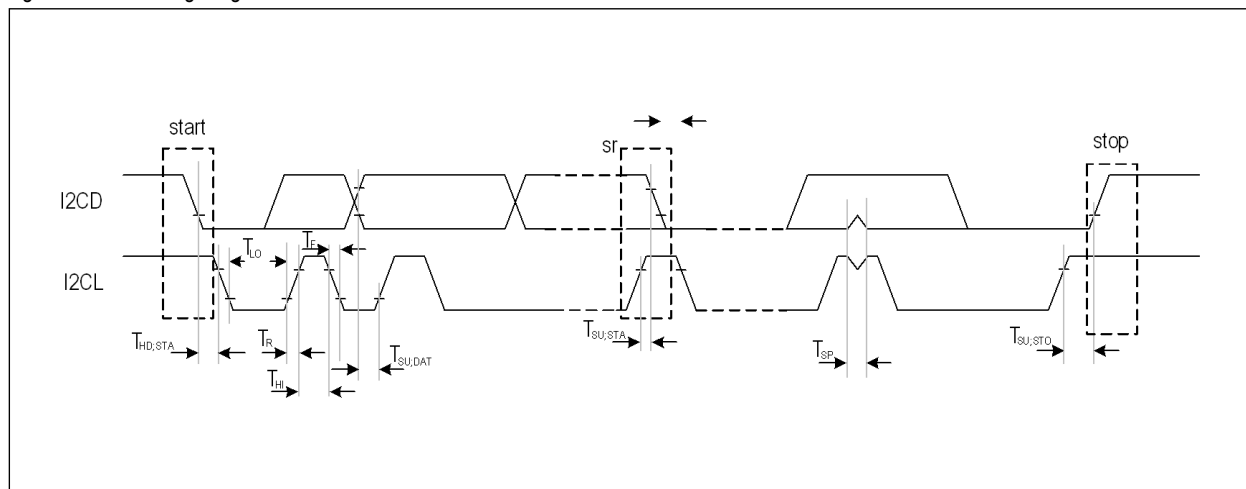

Table 14. I<sup>2</sup>C Parameters

Symbol	Parameter	Conditions	Min	Typ	Max	Units
TSP	Spike intensity		50	100		ns
THI	High Clock Time	400 kHz Clock speed	330			ns
TLO	Low Clock Time		660			ns
TSU		I2CD has to change Tsetup before rising edge I2CL	30			ns
THD		No hold time needed for I2CD relative to rising edge of I2CL	-40			ns
THD;STA	Within start condition, after low going I2CD, I2CL has to stay constant for specified hold time		300			ns
TSU;STO	After high going edge of I2CL, I2CD has to stay constant for the specified setup time before STOP or repeated start condition is applied		100			ns
TSU;STA			100			ns



### 8.5.1 I<sup>2</sup>C Byte Write

The transmission begins with a START condition (S), which consists of a high-to-low transition of the I<sup>2</sup>C bus when I<sup>2</sup>CL is high. The START condition is followed by the Device Write mode (DW), word address (WA: register address to write into) and the register data (reg\_dat). Until the stop condition (P) the word address is automatically incremented at any register data.

Figure 17. I<sup>2</sup>C Byte Write

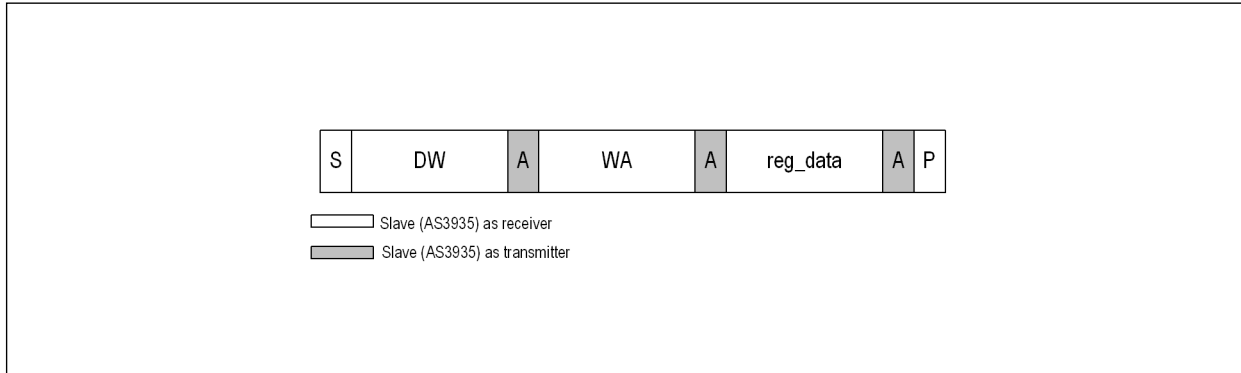
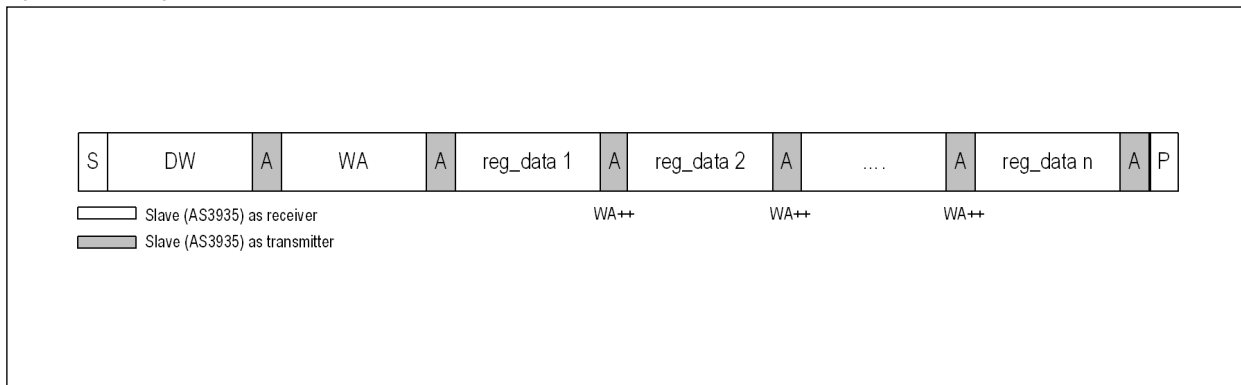

Figure 18. I<sup>2</sup>C Page Write



Symbol	Description
S	START condition after STOP
Sr	Repeated START
DW	Device Address for write
DR	Device Address for read
WA	Word address
A	Acknowledge
N	No acknowledge
P	STOP condition
WA++	Internal address increment

### 8.5.2 I<sup>2</sup>C Register Read

To read data from the slave device, the master has to change the transfer direction. This can be done either with a repeated START condition followed by the device-read address, or simply with a new transmission START followed by the device-read address, when the bus is in IDLE state. The device-read address is always followed by the 1st register byte transmitted from the slave. In Read Mode, any number of subsequent register bytes can be read from the slave. The word address is incremented internally.

Figure 19. I<sup>2</sup>C Page Read

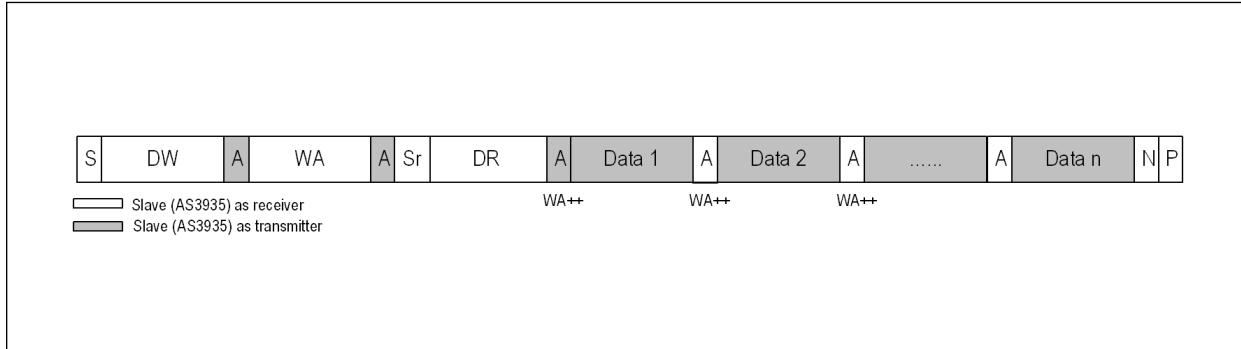

Random Read and Sequential Read are combined formats. The repeated START condition is used to change the direction after the data transfer from the master.

The word address transfer is initiated with a START condition issued by the master while the bus is idle. The START condition is followed by the device-write address and the word address.

In order to change the data direction, a repeated START condition is issued on the 1st CLK pulse after the ACKNOWLEDGE bit of the word address transfer. After the reception of the device-read address, the slave becomes the transmitter. In this state, the slave transmits register data located by the previous received word address vector. The master responds to the data byte with a NOT ACKNOWLEDGE, and issues a STOP condition on the bus.

In contrast to the Random Read, in a sequential read the transferred register-data bytes are responded by an acknowledge from the master. The number of data bytes transferred in one sequence is unlimited (consider the behavior of the word-address counter). To terminate the transmission, the master has to send a NOT ACKNOWLEDGE following the last data byte and subsequently generate the STOP condition.

### 8.5.3 Direct Command

It is possible to send direct commands writing 0x96 in the registers REG0x3C and REG0x3D, as shown in the table below:

Direct Command	Register
PRESET_DEFAULT	0x3C
CALIB_RCO	0x3D

## 8.6 Voltage Regulator

The AS3935 can be either supplied by a voltage regulator or directly.

If the voltage regulator is used, an additional current consumption (around 5µA) will have to be considered. In this case the pin EN\_VREG must be connected to VDD and the AS3935 is supplied by the pin VDD, while the regulated voltage is at the pin VREG (output of the voltage regulator). In order to fulfil the stability requirements of the voltage regulator a capacitance greater than 1µF on the pin VREG to ground is needed. The nominal output regulated voltage is 3V.

If the voltage regulator is not used, the pin EN\_VREG must be connected to ground and the pins VDD and VREG must be connected together to the supply voltage (e.g. battery).

## 8.7 Analog Front-end (AFE) and Watchdog

The AFE amplifies and demodulates the AC-signal picked up by the antenna. Since the AS3935 is a lightning sensor based on narrowband receiving technique (center frequency of 500kHz and a bandwidth of about 33kHz), the AFE bandwidth is meant to be greater than the antenna bandwidth. In this way, it is possible to consider that the gain within the antenna bandwidth as constant.

The gain of the AFE by default is optimized to operate indoor (e.g. inside a building). If the AS3935 operates outdoor, then the AFE gain setting has to be set to a lower value, as shown in the Table 15. Indoor and Outdoor setting must be selected according to the type of the application.

Table 15. AFE Setting, Outdoor vs. Indoor

AFE Setting	REG0x00[5:1]
Indoor	10010
Outdoor	01110

The output signal of the AFE is monitored by the watchdog, which enables the signal validation (see [Signal Verification on page 11](#)) in case the input signal crosses a certain threshold. The AS3935 is automatically set back to Listening Mode once the Signal Validation block has made an assessment on the nature of the received signal (lightning or disturber). With register REG0x01[3:0] it is possible to change the level of this threshold to increase the robustness to disturbers. If higher thresholds are used, the AS3935 would loose sensitivity for very far lightning events, with an improvement of the man-made disturber rejection as benefit.

Figure 20 shows the degradation of the detection efficiency (sensitivity of lightning detection) over the distance for different threshold settings.

Figure 20. Detection Efficiencies vs. Distance for Different Settings for WDTH, if SREJ=0000

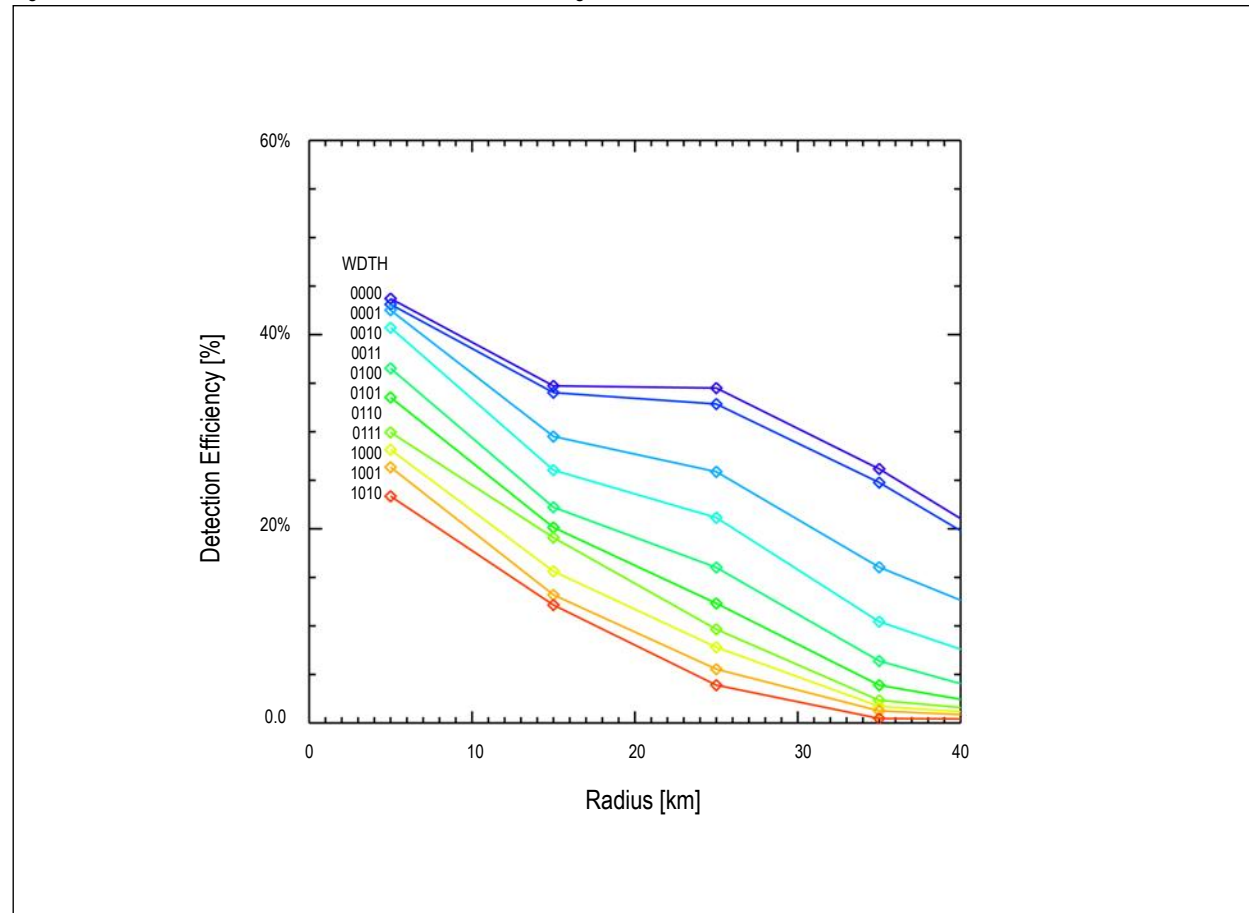

## 8.8 Noise Floor Generator and Evaluation

The output signal of the AFE is also used to generate the noise floor level. The noise floor is continuously compared to a reference voltage (noise threshold). Whenever the noise floor level crosses the noise threshold, the AS3935 issues an interrupt (INT\_NH) to inform the external unit (e.g. MCU) that the AS3935 cannot operate properly due to the high input noise received by the antenna (e.g. blocker). It is possible to set the threshold for the noise floor limit with the bits REG0x01[6:4], as defined in the table below.

Table 16. Settings for the Noise Floor Threshold

Continuous Input Noise Level [ $\mu$ Vrms] (outdoor)	Continuous Input Noise Level [ $\mu$ Vrms] (indoor)	REG0x01[6]	REG0x01[5]	REG0x01[4]
390	28	0	0	0
630	45	0	0	1
860	62	0	1	0
1100	78	0	1	1
1140	95	1	0	0
1570	112	1	0	1
1800	130	1	1	0
2000	146	1	1	1

INT\_NH is displayed as long as the input noise level (blocker) is higher than the noise floor threshold. By default the setting REG0x01[6:4] =010 is used.

## 8.9 Lightning Algorithm

The lightning algorithm consists of hardwired logic. False events (man-made disturbers) which might trigger the AS3935 are rejected, while lightning events initiate calculations to estimate the distance to the head of the storm.

The Lightning algorithm is broken up into three sub blocks:

1. Signal validation: Verification that the incoming signal can be classified as lightning.
2. Energy calculation: Calculation of the energy of the single event.
3. Statistical distance estimation: According to the number of stored events (lightning), a distance estimate is calculated.

If the signal validation fails (the incoming signal does not have the characteristics of lightning), the energy calculation and statistical distance estimation do not happen and the event is classified as disturber.

### 8.9.1 Signal Validation

The watchdog enables the lightning algorithm block in the event any activities are detected at the antenna. As this happens the output signal of the AFE is evaluated by the Signal Validation block, which checks the pattern of the received signal. The signal validation checks the shape of the received signal. In particular, the AS3935 can reject the impulse signals, like spikes, picked up by the antenna. The AS3935 has the ability to improve the spike rejection with the register REG0x02[3:0]. By default, register REG0x02[3:0] =0010. Larger values in REG0x02[3:0] correspond to more robust disturber rejection, with a decrease of the detection efficiency, as shown in the [Figure 21](#).

Figure 21. Detection Efficiencies vs. Distance for Different Setting of SREJ, if WDTM=0001

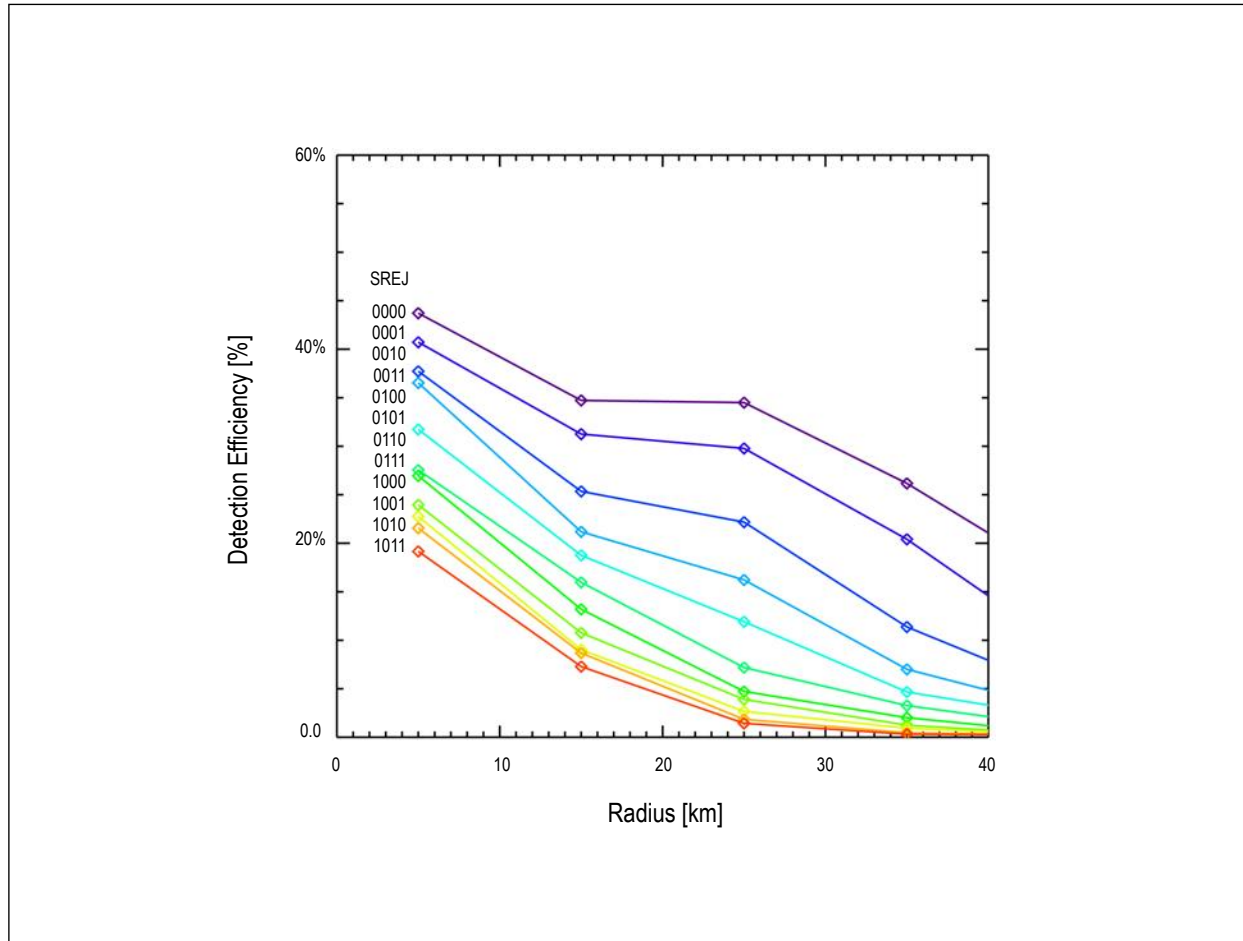

At the end of the signal verification, the AS3935 automatically returns to listening mode.

### 8.9.2 Energy Calculation

If the received signal is classified as lightning, the energy is calculated. The result of the energy calculation is then stored in the registers REG0x06[4:0], REG0x05[7:0] and REG0x04[7:0]. This value is just a pure number and has no physical meaning.

### 8.9.3 Statistical Distance Estimation

The AS3935 generates an assessment of the estimated distance to the head of an approaching storm. This assessment is done based on statistical calculation. The energy of the single event (lightning) provided by the Energy Calculation block is stored in an internal memory, together with timing information, in the AS3935. The events stored in the memory are then correlated with a look-up table by the statistical distance estimation block, which provides a final estimation of the distance to the head of the storm. The algorithm automatically deletes events, which are older than a certain time. R7=0x01 means that the storm is right overhead, while R7=0x3F is displayed when the storm is out of range. This algorithm is hardwired and not accessible from outside.

The estimated distance is directly represented in km in the register REG0x07[5:0] (binary encoded). The distance estimation can change also if no new event triggers the AS3935, as older events can be purged.

Table 17. Distance Estimation

REG0x07[5:0]	Distance [km]
111111	Out of range
101000	40
100101	37
100010	34

Table 17. Distance Estimation

REG0x07[5:0]	Distance [km]
011111	31
011011	27
011000	24
010100	20
010001	17
001110	14
001100	12
001010	10
001000	8
000110	6
000101	5
000001	Storm is Overhead

The calculated energy is stored in registers REG0x04[7:0], REG0x05[7:0] and REG0x06[4:0].

#### 8.9.4 Interrupt Management

Whenever events happen, the AS3935 pulls the IRQ high and displays the interrupt in the REG0x03[3:0]. Table 18 shows the interrupt register.

Table 18. Interrupts

Interrupt Name	REG0x03[3:0]	Description
INT_NH	0001	Noise level too high
INT_D	0100	Disturber detected
INT_L	1000	Lightning interrupt

The INT\_NH is issued if the received noise exceeds the maximum acceptable noise. INT\_NH persists until the noise is again back to low.

In case the signal validation block assesses the received signal as disturber, the INT\_D is displayed. It is possible to mask the disturber interrupts INT\_D with MASK\_DIST (REG0x03[5]=1).

If the MASK\_DIST option is enabled, the signal on the pin IRQ never goes high if a disturber is detected.

The interrupt bus IRQ is set back to low whenever the interrupt register is read out.

The AS3935 issues a lightning interrupt (INT\_L) if a new event is detected. All new events are stored in the internal memory and build up a lightning statistic used by the distance estimation algorithm. If the AS3935 issues an interrupt and the Interrupt register is REG0x03[3:0]=000 the distance estimation has changed due to purging of old events in the statistics, based on the lightning distance estimation algorithm.

Whenever an interrupt is issued, the external unit should wait 2ms before reading the Interrupt register.

In addition, it is possible to allow the AS3935 to issue lightning interrupts only if a minimum number of events (lightning) have been detected in the last 17 minutes. The minimum number of lightning events can be set with register REG0x02[5:4].

Table 19. Minimum Number of Lightning Detection

Minimum Number of Lightning	REG0x02[5]	REG0x02[4]
1	0	0
5	0	1
9	1	0
16	1	1

When this feature is utilized, a minimum number of events must occur to trigger a valid lightning event. This eliminates false triggers by man-made disturbers that may pass the validation algorithm. It is possible to clear the statistics built up by the lightning distance estimation algorithm block by just toggling the bit REG0x02[6] (high-low-high).

## 8.10 Antenna Tuning

The AS3935 uses a loop antenna based on a parallel LC resonator. The antenna has to be designed to have its resonance frequency at 500kHz and a quality factor of around 15. With a register setting it is possible to display on the IRQ pin the resonance frequency of the antenna as a digital signal with the register REG0x08[7] =1. The external unit can measure this frequency and tune the antenna adding or removing the internal capacitors with the register REG0x08[3:0]. It is necessary to tune the antenna with an accuracy of  $\pm 3.5\%$  to optimize the performance of the signal validation and distance estimation. The resonance frequency is internally divided by a factor, which is programmable with the register REG0x03[7:6]. Table 20 shows the division ratio.

Table 20. Frequency Division Ratio for the Antenna Tuning

Division Ratio	REG0x03[7]	REG0x03[6]
16	0	0
32	0	1
64	1	0
128	1	1

## 8.11 Clock Generation

The clock generation is based on two different RC oscillators: a system RCO (SRCO) and a timer RCO (TRCO). The SRCO will run at about 1.1MHz and provides the main clock for the whole digital part. The TRCO is a low power low frequency oscillator and runs at 32.768 kHz. Frequency variations in these two oscillators, due to temperature change, are automatically compensated.

The output frequency of those oscillators can be displayed on the IRQ pin with register setting (REG0x08[5] =1 TRCO, while REG0x08[6] =1 SRCO). Due to process variations, the frequency of both oscillators can be different from the nominal frequency. Therefore, it is possible to calibrate both with a direct command. The precision of the calibration will depend on the accuracy of the resonance frequency of the antenna. It is recommended to first trim the receiver antenna before the calibration of both oscillators is done.

The result of calibration of the 3 oscillators is stored in a volatile memory and needs to be done every time after POR (e.g. battery change) but all oscillators are internally compensated in temperature and voltage supply variations.

If the AS3935 is set in power-down mode, the TRCO needs to be recalibrated using the following procedure:

1. Send Direct command CALIB\_RCO
2. Modify REG0x08[5] = 1
3. Wait 2ms
4. Modify REG0x08[5] = 0

## 9 Package Drawings and Markings

The device is available in a 16LD MLPQ (4x4mm) package.

Figure 22. Drawings and Dimensions

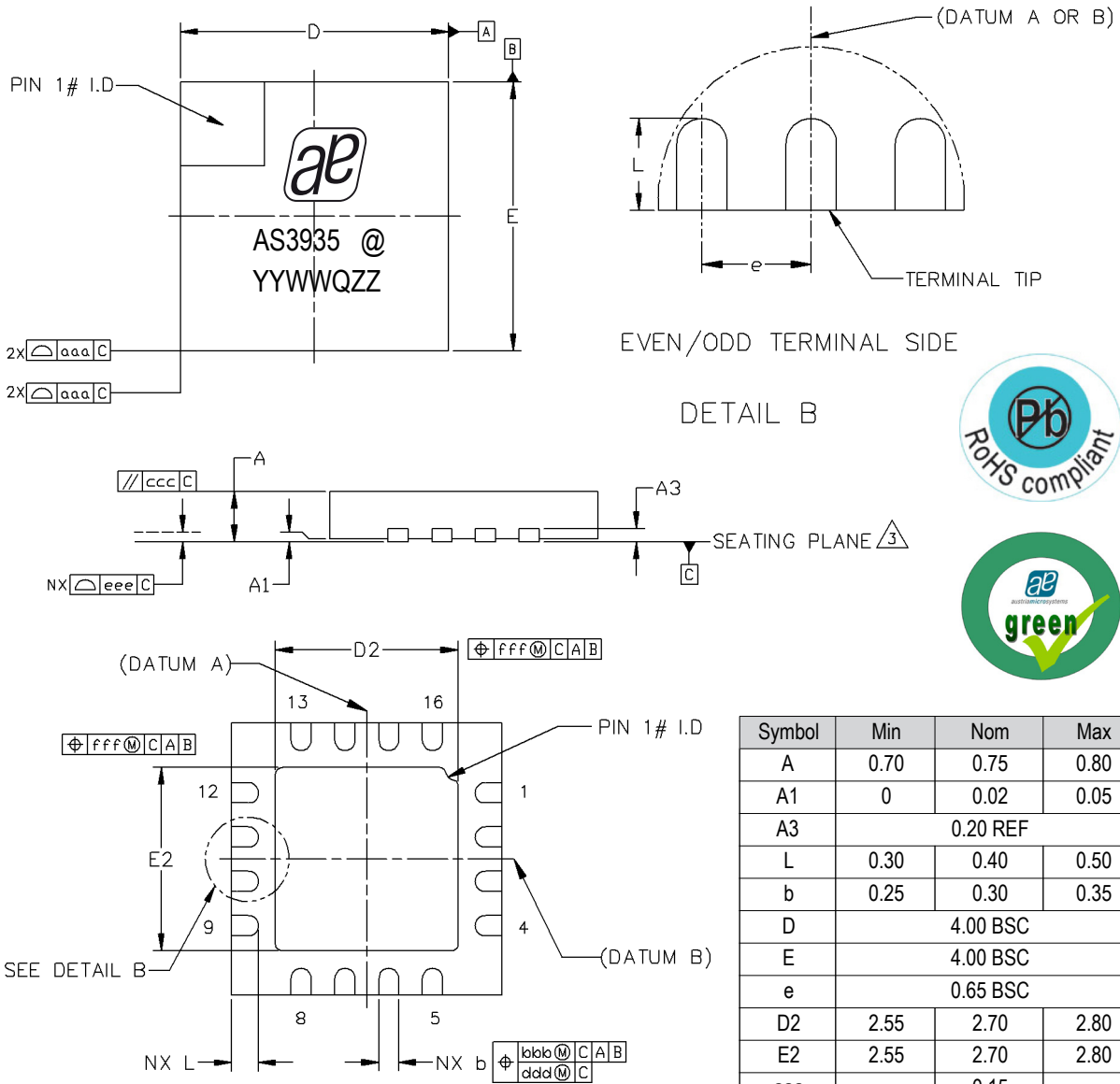

**Notes:**

1. Dimensions & tolerancing conform to ASME Y14.5M-1994.
2. All dimensions are in millimeters. Angles are in degrees.
3. Coplanarity applies to the exposed heat slug as well as the terminal.
4. Radius on terminal is optional.
5. N is the total number of terminals.

Symbol	Min	Nom	Max
A	0.70	0.75	0.80
A1	0	0.02	0.05
A3	0.20 REF		
L	0.30	0.40	0.50
b	0.25	0.30	0.35
D	4.00 BSC		
E	4.00 BSC		
e	0.65 BSC		
D2	2.55	2.70	2.80
E2	2.55	2.70	2.80
aaa	-	0.15	-
bbb	-	0.10	-
ccc	-	0.10	-
ddd	-	0.05	-
eee	-	0.08	-
fff	-	0.10	-
N	16		

Marking: YYWWQZZ.

YY	WW	Q	ZZ	@
Year	Manufacturing Week	Plant identification letter	Traceability code	Sublot identifier



## Revision History

Revision	Date	Owner	Description
1.0	30 Apr, 2012	rlc	Initial release
1.1	14 May, 2012		Corrected error in marking code
1.2	10 Jul, 2012	jpe / msc	Updated info for exposed pad in <a href="#">Table 1</a> , current consumption in <a href="#">Table 7</a> , <a href="#">Section 8.1</a> , <a href="#">Section 8.2</a> , <a href="#">Figure 19</a> , <a href="#">Section 8.7</a> , dimensions info in <a href="#">Section 9</a> .

**Note:** Typos may not be explicitly mentioned under revision history.

## 10 Ordering Information

Table 21. Ordering Information

Ordering Code	Package Type	Marking	Delivery Form	Quantity
AS3935-BQFT	MLPQ 4x4 16LD	AS3935	7 inches Tape & Reel	1000 pcs

**Note:** All products are RoHS compliant and austriamicrosystems green.

Buy our products or get free samples online at ICdirect: <http://www.austriamicrosystems.com/ICdirect>

Technical Support is available at <http://www.austriamicrosystems.com/Technical-Support>

For further information and requests, please contact us [mailto: sales@austriamicrosystems.com](mailto:sales@austriamicrosystems.com)  
or find your local distributor at <http://www.austriamicrosystems.com/distributor>

## Copyrights

Copyright © 1997-2012, austriamicrosystems AG, Tobelbaderstrasse 30, 8141 Unterpremstaetten, Austria-Europe. Trademarks Registered ®. All rights reserved. The material herein may not be reproduced, adapted, merged, translated, stored, or used without the prior written consent of the copyright owner.

All products and companies mentioned are trademarks or registered trademarks of their respective companies.

## Disclaimer

Devices sold by austriamicrosystems AG are covered by the warranty and patent indemnification provisions appearing in its Term of Sale. austriamicrosystems AG makes no warranty, express, statutory, implied, or by description regarding the information set forth herein or regarding the freedom of the described devices from patent infringement. austriamicrosystems AG reserves the right to change specifications and prices at any time and without notice. Therefore, prior to designing this product into a system, it is necessary to check with austriamicrosystems AG for current information. This product is intended for use in normal commercial applications. Applications requiring extended temperature range, unusual environmental requirements, or high reliability applications, such as military, medical life-support or life-sustaining equipment are specifically not recommended without additional processing by austriamicrosystems AG for each application. For shipments of less than 100 parts the manufacturing flow might show deviations from the standard production flow, such as test flow or test location.

The information furnished here by austriamicrosystems AG is believed to be correct and accurate. However, austriamicrosystems AG shall not be liable to recipient or any third party for any damages, including but not limited to personal injury, property damage, loss of profits, loss of use, interruption of business or indirect, special, incidental or consequential damages, of any kind, in connection with or arising out of the furnishing, performance or use of the technical data herein. No obligation or liability to recipient or any third party shall arise or flow out of austriamicrosystems AG rendering of technical or other services.

This product is intended to be used as an early warning indicator for lightning related storms. It does not guarantee accuracy or predict exact strike locations. By using the part, the user shall be aware that s/he cannot just rely on the indication in order to prevent accidents caused by lightning strikes. austriamicrosystems explicitly states that the user must follow the generally known and recommended instructions on how to behave in the event of lightning strikes. In no event shall austriamicrosystems or its suppliers be liable for any direct, indirect, incidental, special, exemplary or consequential damages (including, but not limited to procurement of substitute goods or services, loss of use, data or profits, or business interruption) arising out of user's disregard to such warnings and instructions.



## Contact Information

### Headquarters

austriamicrosystems AG  
Tobelbaderstrasse 30  
A-8141 Unterpremstaetten, Austria

Tel: +43 (0) 3136 500 0  
Fax: +43 (0) 3136 525 01

For Sales Offices, Distributors and Representatives, please visit:

<http://www.austriamicrosystems.com/contact>

## Данный компонент на территории Российской Федерации

### Вы можете приобрести в компании MosChip.

Для оперативного оформления запроса Вам необходимо перейти по данной ссылке:

<http://moschip.ru/get-element>

Вы можете разместить у нас заказ для любого Вашего проекта, будь то серийное производство или разработка единичного прибора.

В нашем ассортименте представлены ведущие мировые производители активных и пассивных электронных компонентов.

Нашей специализацией является поставка электронной компонентной базы двойного назначения, продукции таких производителей как XILINX, Intel (ex.ALTERA), Vicor, Microchip, Texas Instruments, Analog Devices, Mini-Circuits, Amphenol, Glenair.

Сотрудничество с глобальными дистрибьюторами электронных компонентов, предоставляет возможность заказывать и получать с международных складов практически любой перечень компонентов в оптимальные для Вас сроки.

На всех этапах разработки и производства наши партнеры могут получить квалифицированную поддержку опытных инженеров.

Система менеджмента качества компании отвечает требованиям в соответствии с ГОСТ Р ИСО 9001, ГОСТ РВ 0015-002 и ЭС РД 009

### Офис по работе с юридическими лицами:

105318, г.Москва, ул.Щербаковская д.3, офис 1107, 1118, ДЦ «Щербаковский»

Телефон: +7 495 668-12-70 (многоканальный)

Факс: +7 495 668-12-70 (доб.304)

E-mail: [info@moschip.ru](mailto:info@moschip.ru)

Skype отдела продаж:

moschip.ru

moschip.ru\_4

moschip.ru\_6

moschip.ru\_9