

MLX90242

Linear Hall Effect Sensor

Features and Benefits

- Quad Switched Hall Plate / Chopper Stabilized Amplifier
- Ratiometric Output for A/D Interface
- Low Quiescent Voltage Thermal Drift
- Small Plastic Packages (TSOT, TO-92)
- RoHS compliant TSOT package

Applications

- Linear Position Sensing
- Rotary Position Sensing
- Current Sensing

Ordering information

Product Code	Temperature Code	Package Code	Option Code	Packing Form Code
MLX90242	L	UA	GAA-000	BU
MLX90242	L	UA	GAA-000	RE
MLX90242	L	UC	GAA-000	WB
MLX90242	E	SE	GAA-000	RE
MLX90242	E	SE	GDA-000	RE
MLX90242	E	UC	GAA-000	WB

Legend:

Temperature Code: L for Temperature Range -40°C to 150°C
E for Temperature Range -40°C to 85°C

Package Code: SE for TSOT, UA for TO-92, UC for Die on wafer

Option Code: AAA-xxx: Die version
xxx-000: Standard version

Packing Form: RE for Reel
BU for Bulk
WB for Waferbox

Ordering example: MLX90242LUA-GAA-000-RE

Contents

Features and Benefits.....	1
Applications.....	1
Ordering information	1
1. Functional Diagram	3
2. Description	3
3. Glossary of Terms.....	3
4. Absolute Maximum Ratings.....	3
5. MLX90242 Electrical Specifications.....	4
6. MLX90242 Magnetic Specifications	4
7. Applications Information	5
8. Standard Information	6
9. ESD Precautions.....	6
10. Package Information.....	7
10.1. UA Package.....	7
10.2. TSOT Package (RoHS compliant)	8
11. Contact.....	9
12. Disclaimer.....	9

1. Functional Diagram

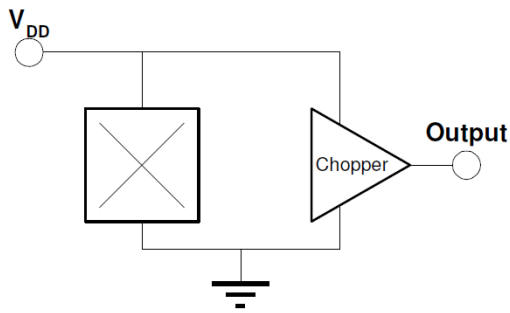

Package	Pin1	Pin2	Pin 3	Slope
TSOT	V _{DD}	Out	V _{SS}	Positive
UA	V _{DD}	V _{SS}	Out	Negative

2. Description

The MLX90242 is a CMOS Linear Hall Effect sensor IC. It possesses active error correction circuitry which virtually eliminates the offset errors normally associated with analog Hall Effect devices.

The ratiometric output voltage is proportional to the supply voltage. When using the supply voltage as a reference for an A/D converter, fluctuations of $\pm 10\%$ in supply voltage will not affect accuracy. For a positive slope, the voltage at the output will increase as a South magnetic field is applied to the branded face of the MLX90242. Conversely, the voltage output will decrease in the presence of a North magnetic field. For a negative slope, the voltage at the output will increase as a North magnetic field is applied to the branded face of the MLX90242. Conversely, the voltage output will decrease in the presence of a South magnetic field.

3. Glossary of Terms

- Gauss, Tesla: Two units to quantify a magnetic flux density. Conversion: 1 mT = 10 Gauss
- Voq: Quiescent output voltage. Output voltage for B = 0mT.

4. Absolute Maximum Ratings

Supply Voltage (Over Voltage), V _{DD}	7.0 V
Output Current Short to V _{DD}	5 mA
Output Current Short to V _{SS}	0.5 mA
Output Pin Short to V _{SS} Pin	Infinite
Output Over Voltage	8 V
Operating Temperature Range, T _A	-40°C to 150°C
Storage Temperature Range, T _S	-55°C to 150°C
Maximum Junction Temp, T _J	170°C
Magnetic Flux Density	Infinite

Exceeding the absolute maximum ratings may cause permanent damage. Exposure to absolute-maximum-rated conditions for extended periods may affect device reliability.

5. MLX90242 Electrical Specifications

DC Operating Parameters. L: $T_A = -40$ to 150°C , E: $T_A = -40$ to 85°C
 $V_{DD} = 5.0\text{V}$ (Unless otherwise specified)

Parameter	Symbol	Test Conditions	Min	Typ	Max	Units
Supply Voltage	VDD	Operating	4.5	5.0	5.5	V
Supply Current	IDD	B = 0mT, VDD = 5V, IOU _T = 0mA VDD = 5V	1.8	2.5	4.5	mA
Output Current	IOU _T	Pull-up = 5 k Ω , Pull-down = 50 k Ω	-1.0	-	0.1	mA
Quiescent Output Voltage	VOQ	B = 0mT, T _A = 25 $^\circ\text{C}$	2.4	2.5	2.6	V
Output Voltage	VOH	VDD = 5V, IOU _T = -1.0 mA	4.75			V
Output Voltage	VOL	VDD = 5V, IOU _T = 0.1 mA			0.25	V
Response Time	tr	VDD=5V, Vout from VOQ to VOH/VOL without load		400	800	μs
Noise (RMS)				5	10	mV
Output Resistance	ROUT			20		Ω
Linearity Error	Le				0.5	%Vdd

6. MLX90242 Magnetic Specifications

$V_{DD} = 5.0\text{V}$ (Unless otherwise specified)

Parameter	Symbol	MLX90242 LUA-GAA-000			MLX90242 ESE-GDA-000			MLX90242 ESE-GAA-000		
		Min	Typ	Max	Min	Typ	Max	Min	Typ	Max
Thermal Voq Drift (1) (mV)	ΔTVOQ	-25		25		± 25 (2)			± 25 (2)	
Sensitivity, T _A = 25 $^\circ\text{C}$ (mV/mT)	S	33.2	39.0	44.9	11.5	15	17.3	33.2	39.0	44.9
TC of Sensitivity (ppm/ $^\circ\text{C}$)	TCS	430	680	930		680 (2)			680 (2)	

(1) B = 0 Gauss

(2) For TSOT package, TC of Sensitivity and Thermal Voq Drift are not fully tested and therefore cannot be specified. Characterization and statistic data can be provided by Melexis upon request.

7. Applications Information

C1 and C2 values can be trimmed to satisfied EMC requirements according to the environment (PCB, connectors,...).
The output rise time is affected for large capacitor C2, depending of the couple R1 and C2.

Recommended Wiring

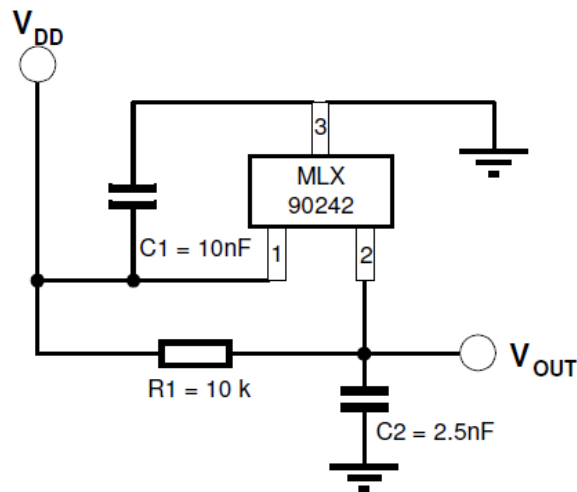

8. Standard Information

Our products are classified and qualified regarding soldering technology, solderability and moisture sensitivity level according to standards in place in Semiconductor industry.

For further details about test method references and for compliance verification of selected soldering method for product integration, Melexis recommends reviewing on our web site the General Guidelines [soldering recommendation](#). For all soldering technologies deviating from the one mentioned in above document (regarding peak temperature, temperature gradient, temperature profile etc), additional classification and qualification tests have to be agreed upon with Melexis.

For package technology embedding trim and form post-delivery capability, Melexis recommends to consult the dedicated trim&form recommendation application note: [lead trimming and forming recommendations](#).

Melexis is contributing to global environmental conservation by promoting **lead free** solutions. For more information on qualifications of **RoHS** compliant products (RoHS = European directive on the Restriction Of the use of certain Hazardous Substances) please visit the quality page on our website: <http://www.melexis.com/en/quality-environment>

9. ESD Precautions

Electronic semiconductor products are sensitive to Electro Static Discharge (ESD).

Always observe Electro Static Discharge control procedures whenever handling semiconductor products.

10. Package Information

10.1. UA Package

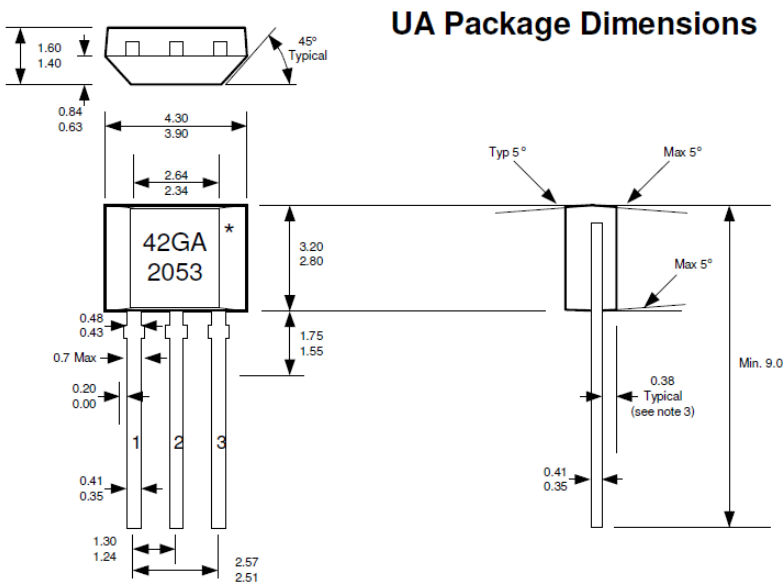

PINOUT:
 Pin 1 V_{DD}
 Pin 2 GND (Vss)
 Pin 3 Output

- NOTES:**
- 1.) Controlling dimension: mm
 - 2.) Leads must be free of flash and plating voids
 - 3.) Leads must not arc toward the rear of package
 - 4.) Package dimensions exclude molding flash
 - 5.) Tolerance is 0.254mm unless otherwise specified

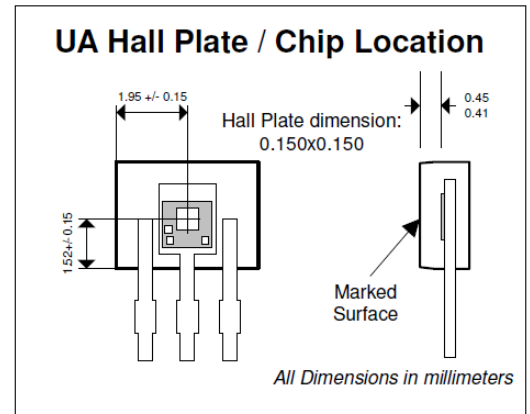

Front side marking
Part Number MLX90242 (2 digits)

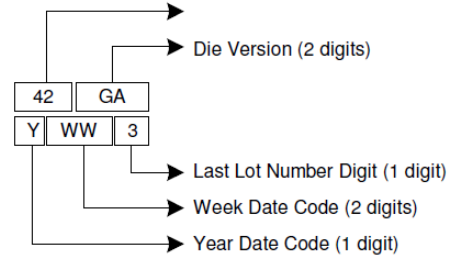

10.2. TSOT Package (RoHS compliant)

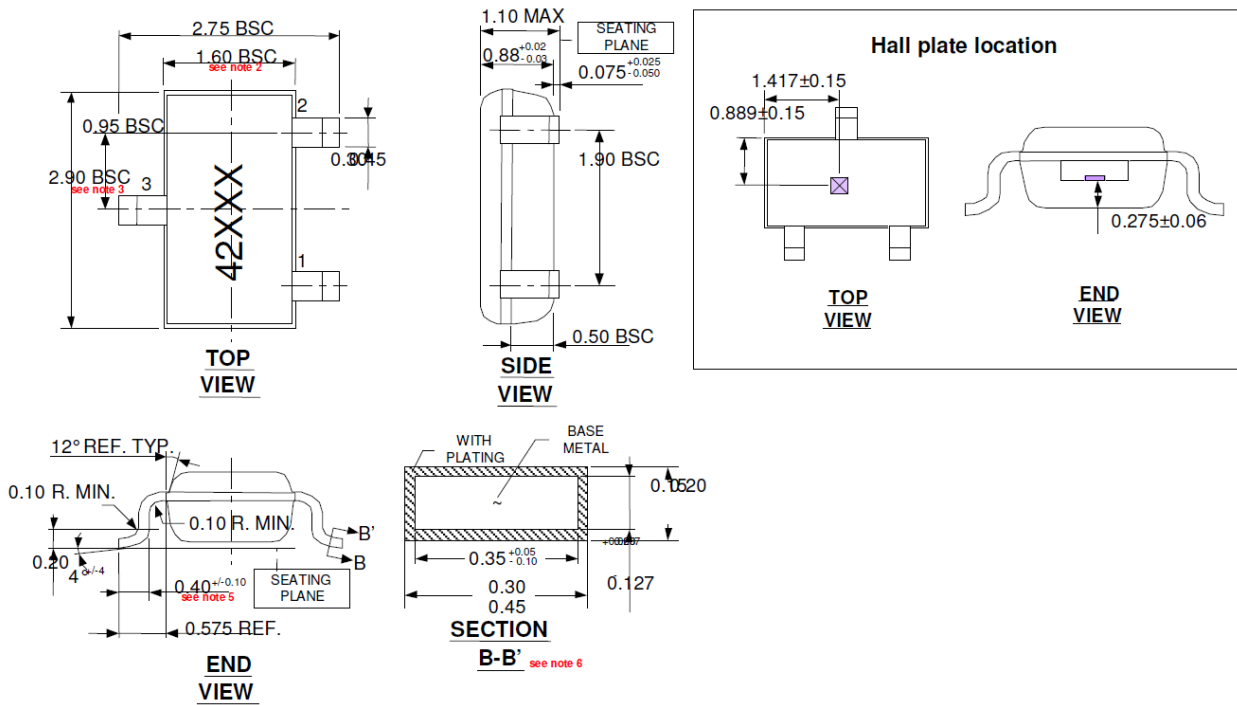

Notes:

1. All dimensions are in millimeters
2. Outermost plastic extreme width does not include mold flash or protrusions. Mold flash and protrusions shall not exceed 0.15mm per side.
3. Outermost plastic extreme length does not include mold flash or protrusions. Mold flash and protrusions shall not exceed 0.25mm per side.
4. The lead width dimension does not include dambar protrusion. Allowable dambar protrusion shall be 0.07mm total in excess of the lead width dimension at maximum material condition.
5. Dimension is the length of terminal for soldering to a substrate.
6. Dimension on SECTION B-B are apply to the flat section of the lead between 0.08mm and 0.15mm from the lead tip.
7. Formed lead shall be planar with respect to one another with 0.076mm at seating plane.

Top Side Marking:

42XXX: 3 last digits of lotnumber (XXX)

Bottom Side Marking:

YYWW : Year (YY) - Week (WW)

11. Contact

For the latest version of this document, go to our website at www.melexis.com.

For additional information, please contact our Direct Sales team and get help for your specific needs:

Europe, Africa	Telephone: +32 13 67 04 95
	Email : sales_europe@melexis.com
Americas	Telephone: +1 603 223 2362
	Email : sales_usa@melexis.com
Asia	Email : sales_asia@melexis.com

12. Disclaimer

The information furnished by Melexis herein ("Information") is believed to be correct and accurate. Melexis disclaims (i) any and all liability in connection with or arising out of the furnishing, performance or use of the technical data or use of the product(s) as described herein ("Product") (ii) any and all liability, including without limitation, special, consequential or incidental damages, and (iii) any and all warranties, express, statutory, implied, or by description, including warranties of fitness for particular purpose, non-infringement and merchantability. No obligation or liability shall arise or flow out of Melexis' rendering of technical or other services.

The Information is provided "as is" and Melexis reserves the right to change the Information at any time and without notice. Therefore, before placing orders and/or prior to designing the Product into a system, users or any third party should obtain the latest version of the relevant information to verify that the information being relied upon is current. Users or any third party must further determine the suitability of the Product for its application, including the level of reliability required and determine whether it is fit for a particular purpose.

The Information is proprietary and/or confidential information of Melexis and the use thereof or anything described by the Information does not grant, explicitly or implicitly, to any party any patent rights, licenses, or any other intellectual property rights.

This document as well as the Product(s) may be subject to export control regulations. Please be aware that export might require a prior authorization from competent authorities.

The Product(s) are intended for use in normal commercial applications. Unless otherwise agreed upon in writing, the Product(s) are not designed, authorized or warranted to be suitable in applications requiring extended temperature range and/or unusual environmental requirements. High reliability applications, such as medical life-support or life-sustaining equipment are specifically not recommended by Melexis.

The Product(s) may not be used for the following applications subject to export control regulations: the development, production, processing, operation, maintenance, storage, recognition or proliferation of 1) chemical, biological or nuclear weapons, or for the development, production, maintenance or storage of missiles for such weapons; 2) civil firearms, including spare parts or ammunition for such arms; 3) defense related products, or other material for military use or for law enforcement; 4) any applications that, alone or in combination with other goods, substances or organisms could cause serious harm to persons or goods and that can be used as a means of violence in an armed conflict or any similar violent situation.

The Products sold by Melexis are subject to the terms and conditions as specified in the Terms of Sale, which can be found at <https://www.melexis.com/en/legal/terms-and-conditions>.

This document supersedes and replaces all prior information regarding the Product(s) and/or previous versions of this document.

Melexis NV © - No part of this document may be reproduced without the prior written consent of Melexis. (2016)

ISO/TS 16949 and ISO14001 Certified

Данный компонент на территории Российской Федерации

Вы можете приобрести в компании MosChip.

Для оперативного оформления запроса Вам необходимо перейти по данной ссылке:

<http://moschip.ru/get-element>

Вы можете разместить у нас заказ для любого Вашего проекта, будь то серийное производство или разработка единичного прибора.

В нашем ассортименте представлены ведущие мировые производители активных и пассивных электронных компонентов.

Нашей специализацией является поставка электронной компонентной базы двойного назначения, продукции таких производителей как XILINX, Intel (ex.ALTERA), Vicor, Microchip, Texas Instruments, Analog Devices, Mini-Circuits, Amphenol, Glenair.

Сотрудничество с глобальными дистрибьюторами электронных компонентов, предоставляет возможность заказывать и получать с международных складов практически любой перечень компонентов в оптимальные для Вас сроки.

На всех этапах разработки и производства наши партнеры могут получить квалифицированную поддержку опытных инженеров.

Система менеджмента качества компании отвечает требованиям в соответствии с ГОСТ Р ИСО 9001, ГОСТ РВ 0015-002 и ЭС РД 009

Офис по работе с юридическими лицами:

105318, г.Москва, ул.Щербаковская д.3, офис 1107, 1118, ДЦ «Щербаковский»

Телефон: +7 495 668-12-70 (многоканальный)

Факс: +7 495 668-12-70 (доб.304)

E-mail: info@moschip.ru

Skype отдела продаж:

moschip.ru

moschip.ru_4

moschip.ru_6

moschip.ru_9