

IS32LT3126 150MA DUAL CHANNEL LED DRIVER WITH FAULT DETECTION

DESCRIPTION

The IS32LT3126 is a dual linear programmable current regulator consisting of 2 independently controlled output channels; each channel is capable of sourcing 150mA. Both channels can be combined to provide a total of 300mA. It supports PWM dimming of both channels via power supply modulation (PSM). It also features ENx pins to individually PWM dim and independently adjusts the average output current for each channel. The max current for each channel is set with its corresponding external resistor.

The UVx pins set the VCC under voltage lockout of each channel to match the LED stack for high side PWM dimming operation. In addition, the IC integrates fault protection for LED open/short, ISETx pin open/short and over temperature condition for robust operation. Detection of these failures is reported by FAULTB pin. When a fault is detected the device will disable itself and output an open drain low signal. Multiple devices can have their FAULTB pins connected to create a “one-fail-all-fail” condition. For multiple LED string applications, the device can detect a single LED short. The single LED short detection is set by a resistor divider on the STx pins. A single LED short failure is reported by the separate FAULTB_S pin.

The IS32LT3126 is targeted at the automotive market with end applications to include interior and exterior lighting. For 12V automotive applications the low dropout driver can support one to several LEDs on the output channels.

QUICK START

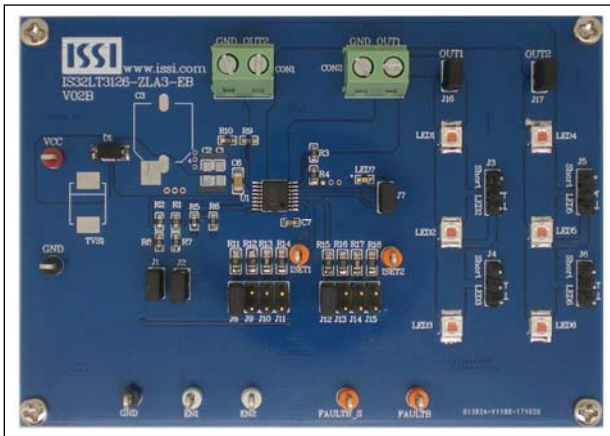

Figure 1: Photo of IS32LT3126 Evaluation Board

FEATURES

- Four output channels can source up to 150mA each
- Dual channel: each channel can source up to 150mA and the two channels combined to source up to 300mA
- External resistors individually set source current
- 4% channel to channel current matching
- Individually programmable VCC under voltage lockout to match the LED stack for PSM operation
- Individual PWM dimming
- Shared fault flag for multiple devices operation
- Fault protection with flag reporting:
 - Single LED short (optional to turn off all LEDs)
 - LED string open/short
 - OUTx pins short to VCC/GND
 - ISETx pins open/short
 - Over temperature current rollback (no reporting)
 - Thermal shutdown
- External CSTR capacitor keeps fault status during start/stop operation
- eTSSOP-16 package
- Operating temperature range from -40°C ~ +125°C
- AEC-Q100 Qualified

RECOMMENDED EQUIPMENT

- 12V,1A DC power supply

ABSOLUTE MAXIMUM RATINGS

- ≤ 40V power supply

Caution: Do not exceed the conditions listed above, otherwise the board will be damaged.

PROCEDURE

The IS32LT3126 evaluation board is fully assembled and tested. Follow the steps listed below to verify board operation.

Caution: Do not turn on the power supply until all connections are completed.

- 1) Connect negative terminal of the power supply to the GND and the positive terminal to the VCC.
- 2) Each output current is individually set by four different value resistors (R_{ISETX}). Close jumper of J8~J15 to select different output current for each channel.

Table 1 Current Setting

Jumper J8,J12	Jumper J9,J13	Jumper J10,J14	Jumper J11,J15
$I_{OUT1}=150mA$	$I_{OUT1}=100mA$	$I_{OUT1}=50mA$	$I_{OUT1}=25mA$
$I_{OUT2}=150mA$	$I_{OUT2}=100mA$	$I_{OUT2}=50mA$	$I_{OUT2}=25mA$



IS32LT3126 150MA DUAL CHANNEL LED DRIVER WITH FAULT DETECTION

3) J16, J17 are used to connect the IS32LT3126's outputs to the onboard LED strings (LED1~LED6). Use the green terminal blocks to connect the external LED strings. Remove the corresponding jumper J16 and J17 to disable the onboard LED string.

Note: Connecting an external LED string without removing the onboard string jumper header will drive both onboard and external LED strings in parallel resulting in lower current drive to the LED string.

4) Close jumper J1, J2 to pull EN1/EN2 pins via 100kΩ resistor to VCC. If apply a PWM signal to EN1/2 pins, please remove corresponding jumper J1 and J2, otherwise the PWM source may be damaged.

5) Close jumper J7, FAULTB and FAULTB_S are tied

together. In the case of single LED short is detected, the FAULTB_S pin pulls down the FAULTB pin together that turns off the no fault condition channel.

6) The on board LED string can be adjusted from 1 to 3 LEDs by using header J3, J4, J5, J6. Close the jumper to pins1-2 of J3,J4,J5,J6 disables the corresponding LED2,LED3,LED5,LED6.To enable all the LEDs close the jumper to pins 2-3 of J3,J4,J5,J6 or remove jumper.

7) R19, R20, C8, ZD1 and LED7 are used as fault reporting indicator.

Note: This circuit is not necessary for real application.

ORDERING INFORMATION

Part No.	Temperature Range	Package
IS32LT3126-ZLA3-EB	-40°C ~ +125°C (Automotive)	eTSSOP-16, Lead-free

Table 1: Ordering Information

For pricing, delivery, and ordering information, please contact ISSI's analog marketing team at analog@issi.com or (408) 969-6600.

Table 2 Jumper Setting

Jumper	Options	Settings
J1,J2	EN setting. If use PWM dimming, please remove jumper J1, J2.	Close jumper: EN1, EN2 pin pulled up to VCC via a 100kΩ resistor and enable the corresponding output. Open jumper: PWM dimming
J3~J6	Number of LED control	Close pin1-2 : disable the corresponding LED Close pin2-3 : enable the corresponding LED
J7	FAULTB and FAULTB_S setting	Close jumper: FAULTB and FAULTB_S are tied together Open jumper: FAULTB and FAULTB_S are separated
J8~J15	Output current setting.	Close jumper to select corresponding resistor. Refer to table 1 for details
J16, J17	Onboard LED strings select.	Close jumper: enable the corresponding onboard LED string Open jumper: disable the corresponding onboard LED string

EVALUATION BOARD OPERATION

OUTPUT CURRENT SETTING

A single resistor (R_{ISETx}) controls the maximum output current for each channel. The resistor value for a specific current level is calculated using the following Equation (1):

$$R_{ISET} = \frac{2000}{I_{SET}} \quad (1)$$

$$(13.33k\Omega \leq R_{ISET} \leq 80k\Omega)$$

R_{ISET} need to be chosen 1% accuracy resistor with good temperature characteristic to ensure stable output current.

The device is protected from an output overcurrent condition caused by a too low value R_{ISETx} , by internally limiting the maximum current to I_{OUT_L} .

IS32LT3126 150MA DUAL CHANNEL LED DRIVER WITH FAULT DETECTION

If only one channel is used, the EN pin of the unused channel should be tied to GND to prevent unwanted fault reporting.

ENx PINS OPERATION

The voltage at the ENx pins must be higher than V_{EN} to enable the channel and below $(V_{EN} - V_{ENHY})$ to disable the channel. The ENx pins of the IS32LT3126 can accept a PWM signal to implement LED dimming. LED average current may be computed using the following Equation (2).

$$I_{LED} = I_{MAX} \times D_{PWM} \quad (2)$$

I_{MAX} is computed using Equation (1) and D_{PWM} is the duty cycle. To guarantee a reasonably good dimming effect, recommend PWM frequency in the range of 100Hz ~ 1kHz. Driving the ENx pins with a PWM signal can effectively adjust the LED intensity. The PWM signal voltage levels must meet the ENx pins input voltage levels, V_{EN} . Tie them to VCC pin via a 10KΩ resistor when ENx pins are unused; do not leave them floating.

UVx PINS OPERATION

The IC has an internal VCC UVLO set at V_{UVLO} . However, it may be desirable to externally set an UVLO to track the number of LED's used in the string. For PSM dimming application, the higher UVLO will track the PSM off time to a pre-determined VCC level. In addition, it is necessary to prevent false LED open detection due to the LED string losing its headroom voltage, such as when VCC rises up from zero during power up or PSM dimming. The UVx pin can be used to independently set a VCC under voltage lockout threshold via a resistor divider for each channel.

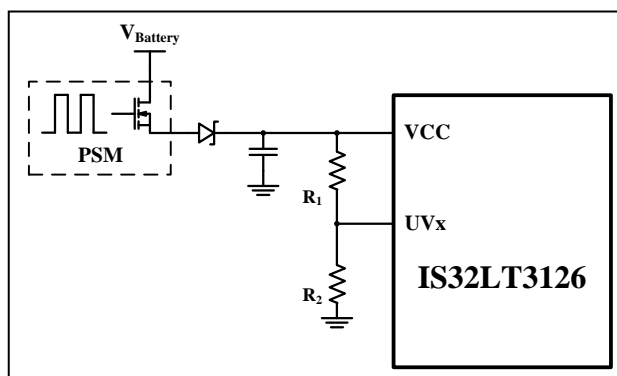

Figure 2 UVx Pins Operation

This external UVLO threshold voltage can be computed using the following Equation (3):

$$V_{CC_UVLO} = V_{UV} \times \frac{R_1 + R_2}{R_2} \quad (3)$$

Any unused UVLO pin must be tied to VCC pin via a 10kΩ resistor; do not leave it floating.

To prevent false open detection, the external UVLO

threshold voltage should be set at Equation (4):

$$V_{CC_UVLO} > V_{LED_MAX} + V_{OCD} \quad (4)$$

Where V_{LED_MAX} is the maximum LED string forward voltage on the output channel.

STx PINS OPERATION

IS32LT3126 device features single LED short detection using a resistor divider on the STx pins. In the case of any single LED short will result in that the STx pin voltage to drop below the threshold voltage V_{ST} and remains for t_{FD} , the FAULTB_S pin pulls low to report the failure to host and all channels continue sourcing current. If FAULTB_S pin is tied to FAULTB pin, the FAULTB_S pin pulls down the FAULTB pin together that turns off the no fault condition channel but keep 4mA sourcing on fault channel for recovery detection. In multiple LEDs per string application, set the detection threshold voltage V_{DT} into below voltage range:

$$(N - 1) \times V_{F_max} < V_{DT} < N \times V_{F_min} \quad (5)$$

Where, N is the number of LEDs in the string. V_{F_max} and V_{F_min} are the maximum and minimum forward voltage of a single LED.

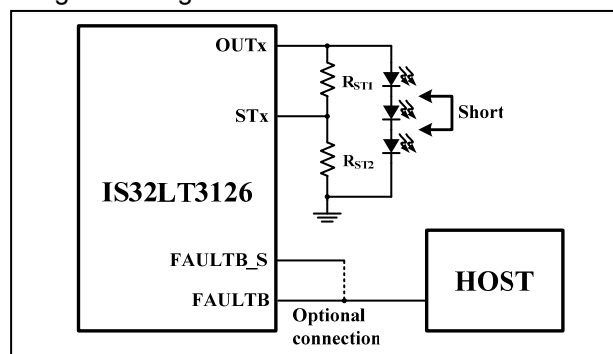

Figure 3 STx Pins Operation

The detection threshold voltage V_{DT} is calculated by the following Equation (6):

$$V_{DT} = V_{ST} \times \frac{R_{ST1} + R_{ST2}}{R_{ST2}} \quad (6)$$

If single LED short detection is unused, the unused STx pin should be tied to its corresponding OUTx pin.

OUTPUT STATE DETECTION AND FAULT DIAGNOSTIC

IS32LT3126 offers a fault diagnostic function. Output short to GND/VCC, LED string open/short, ISET pins short/open and over temperature shutdown will trigger this function.

An output short to GND or VCC is detected as a fault if the OUTx pin voltage drops below the short detect voltage threshold V_{SCD} or VCC to OUTx drop voltage is lower than V_{OCD} and remains below the threshold for

IS32LT3126 150MA DUAL CHANNEL LED DRIVER WITH FAULT DETECTION

t_{FD} . Then the fault channel will change to source a 4mA current for recovery detection and the other channel will turn off. The FAULTB pin will be pulled low to indicate the fault condition. This state will recover after the fault condition is removed.

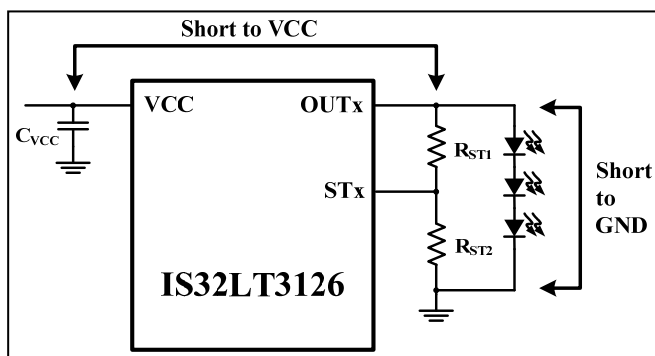

Figure 4 OUTx Pins Short Operation

In the event the LED channel is open circuited, the OUTx pin voltage will go up close to V_{CC} . If V_{CC} to OUTx drop voltage remains below the threshold V_{OCD} for t_{FD} , the fault channel will change to source a 4mA current for recovery detection and the other channel will turn off. The FAULTB pin will be pulled low to indicate the fault condition. The state will recover after the open condition is removed.

If the ISETx pin is either short or open, the FAULTB pin will pull low to assert the fault and the both channels will turn off. The state will recover after the fault condition is removed.

Table 3 Fault Actions

Fault Type	Fault Condition	Fault Channel	Another Channel	FAULTB	FAULTB_S	Recovery
ISETx open	ISETx pin current close to zero	Off	Off	Low	High	ISETx pin current goes back normal
ISETx short	ISETx pin voltage close to zero	Off	Off	Low	High	ISETx pin voltage goes back normal
LED string open (OUTx short to VCC)	$(V_{CC}-V_{OUTx}) < V_{OCD}$	4mA for recovery detection	Off	Low	High	$(V_{CC}-V_{OUTx}) > (V_{OCD}+V_{OCD_HY})$
LED string short (OUTx short to GND)	$V_{OUTx} < V_{SCD}$	4mA for recovery detection	Off	Low	High	$V_{OUTx} > (V_{SCD}+V_{SCD_HY})$
One LED short	STx pin voltage drops below V_{ST}	Keep normal sourcing		High	Low	STx pin voltage rises above $(V_{ST}+V_{STHY})$
	FAULTB_S tied to FAULTB and STx pin voltage drops below V_{ST}	4mA for recovery detection	Off	Pulled low by FAULTB_S	Low	STx pin voltage rises above $(V_{ST}+V_{STHY})$
Thermal rollback	$T_J > T_{RO}$	Output current linearly decreases following T_J		High	High	$T_J < T_{RO}$
Thermal shutdown	$T_J > T_{SD}$	Off		Low	High	$T_J < (T_{SD}-T_{HY})$

IS32LT3126 150MA DUAL CHANNEL LED DRIVER WITH FAULT DETECTION

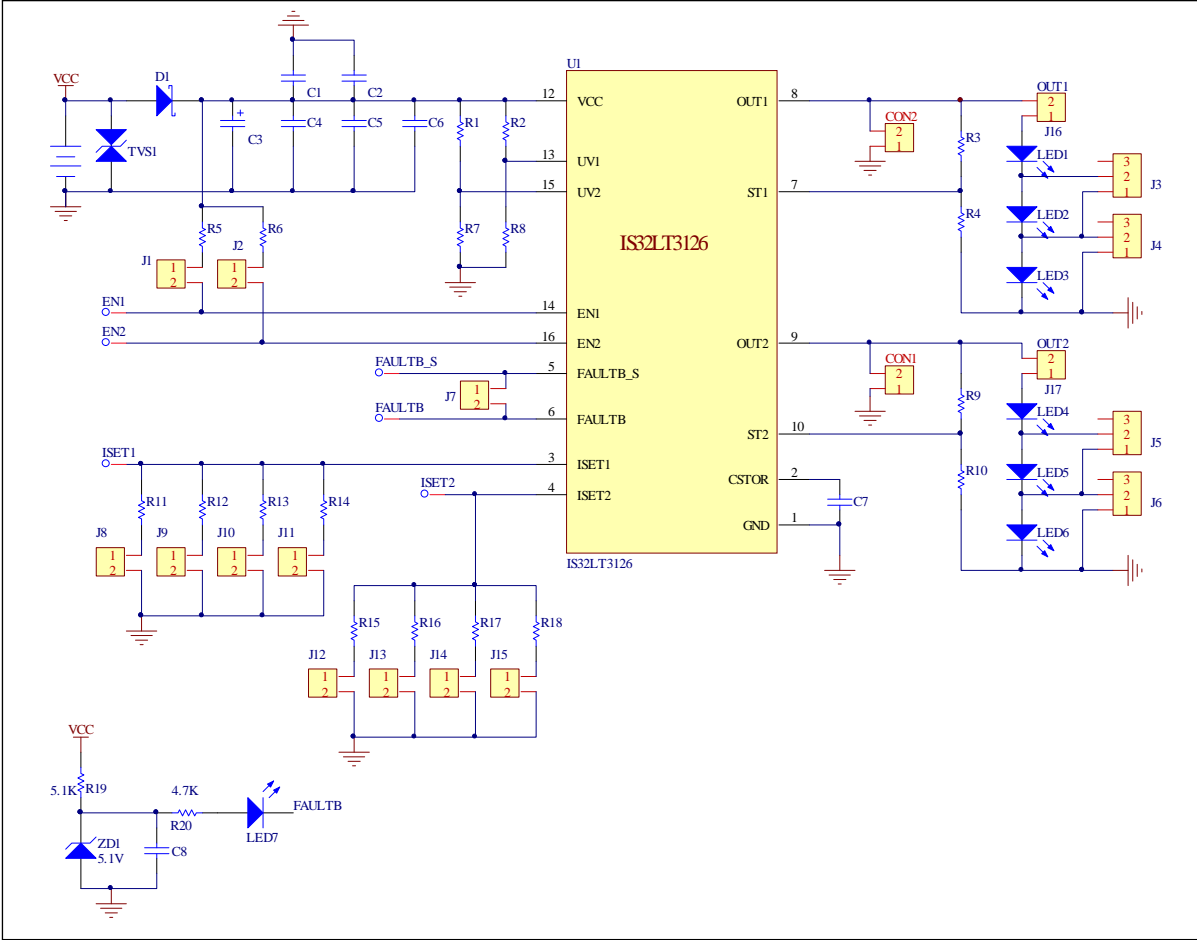

Figure 5: IS32LT3126 DEMO Schematic



IS32LT3126 150MA DUAL CHANNEL LED DRIVER WITH FAULT DETECTION

BILL OF MATERIALS

Name	Symbol	Description	Qty	Supplier	Part No.
LED Driver	U1	LED Driver	1	ISSI	IS32LT3126
Resistor	R1,R2	RES,36K,1/10W,±1%,SMD	2	YAGEO	AC0603FR-0736KL
Resistor	R3,R9	RES,10K,1/10W,±1%,SMD	2	YAGEO	AC0603FR-0710KL
Resistor	R4,R10	RES,3K,1/10W,±1%,SMD	2	YAGEO	AC0603FR-073KL
Resistor	R5,R6	RES,100K,1/10W,±1%,SMD	2	YAGEO	AC0603FR-07100KL
Resistor	R7,R8	RES,6.8K,1/10W,±1%,SMD	2	YAGEO	AC0603FR-076K8L
Resistor	R11,R15	RES,13K,1/8W,±1%,SMD	2	YAGEO	AC0805FR-0713KL
Resistor	R12,R16	RES,20K,1/8W,±1%,SMD	2	YAGEO	AC0805FR-0720KL
Resistor	R13,R17	RES,39K,1/8W,±1%,SMD	2	YAGEO	AC0805FR-0739KL
Resistor	R14,R18	RES,82K,1/8W,±1%,SMD	2	YAGEO	AC0805FR-0782KL
Resistor	R19	RES,5.1K,1/8W,±5%,SMD	1	YAGEO	AC0805JR-075K1L
Resistor	R20	RES,4.7K,1/8W,±5%,SMD	1	YAGEO	AC0603JR-074K7L
Capacitor	C6	CAP,0.1µF,50V,±10%,SMD	1	YAGEO	AC1206KRX7R9BB104
Capacitor	C7	CAP,1µF,10V,±10%,SMD	1	YAGEO	AC0603KRX7R6BB105
Schottky	D1	60V/1A,Diode Schottky	1	ON Semi	SS16FA
LEDs	LED1~LED6	Yellow LED,1W,V _F =2.0~2.2V	6		
Zener	ZD1	ZMM5.1V,0.5W, LL-34	1		
LED	LED7	Red LED,20mA,V _F =1.8V	1		
	C1~C5,C8, TVS1	Not installed	7		
Header	J1,J2	2 pin header	13		
	J7~J17				
Header	J3,J4,J5,J6	3 pin header	4		
Terminal blocks	CON1	Ext terminal blocks	2		
	CON2				

Bill of Materials, refers to Figure 5 above.

IS32LT3126 150MA DUAL CHANNEL LED DRIVER WITH FAULT DETECTION

PCB LAYOUT

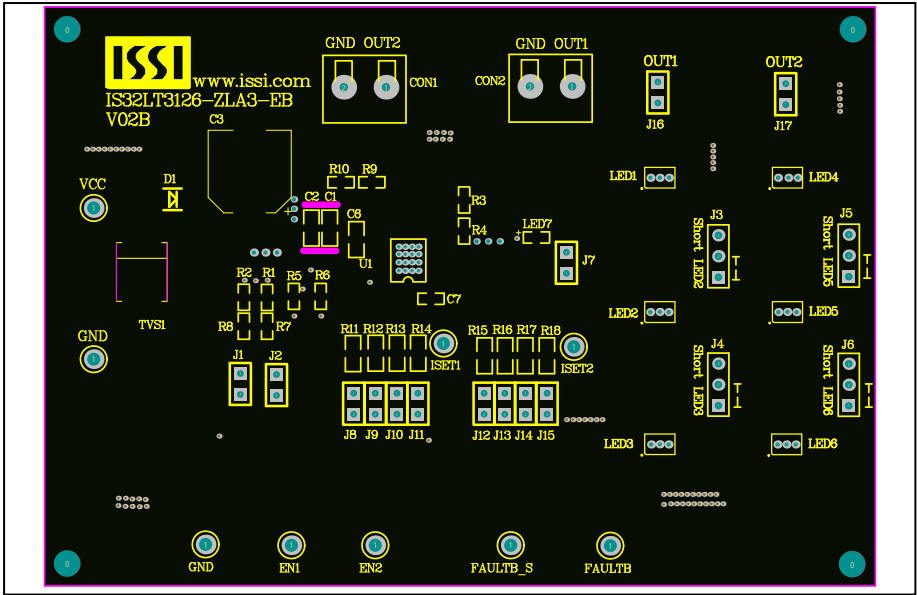

Figure 6 Board Component Placement Guide - Top Layer

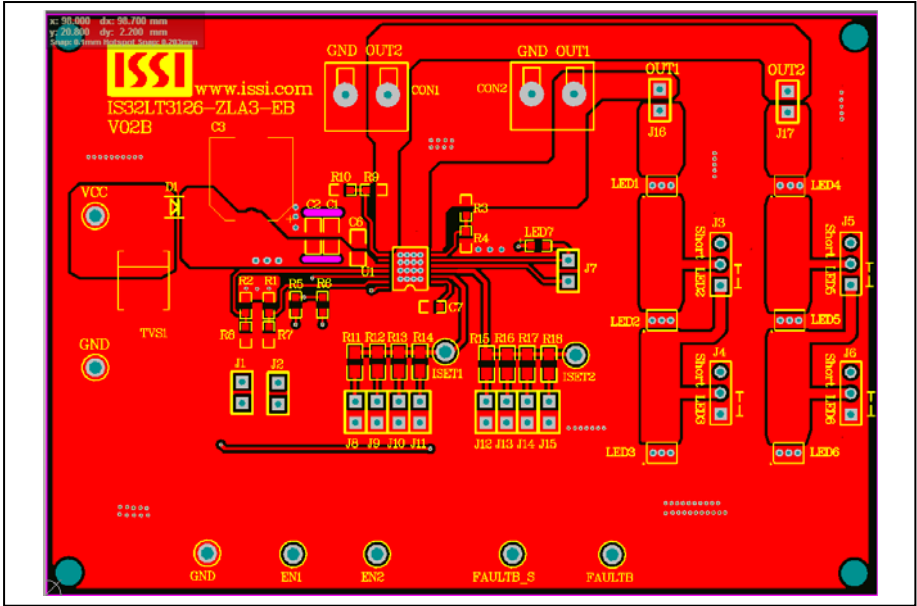

Figure 7 Board PCB Layout- Top Layer

IS32LT3126 150MA DUAL CHANNEL LED DRIVER WITH FAULT DETECTION

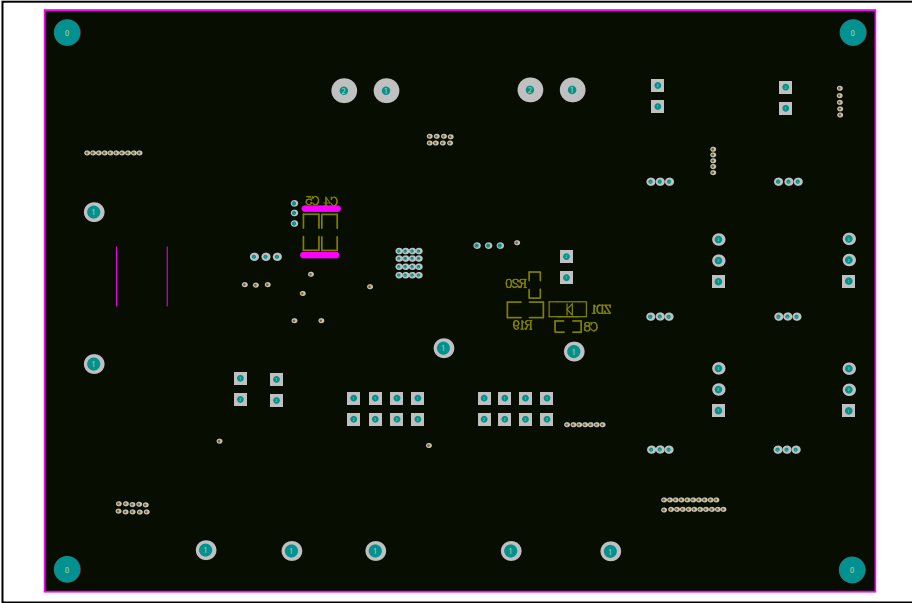

Figure 8 Board Component Placement Guide - Bottom Layer

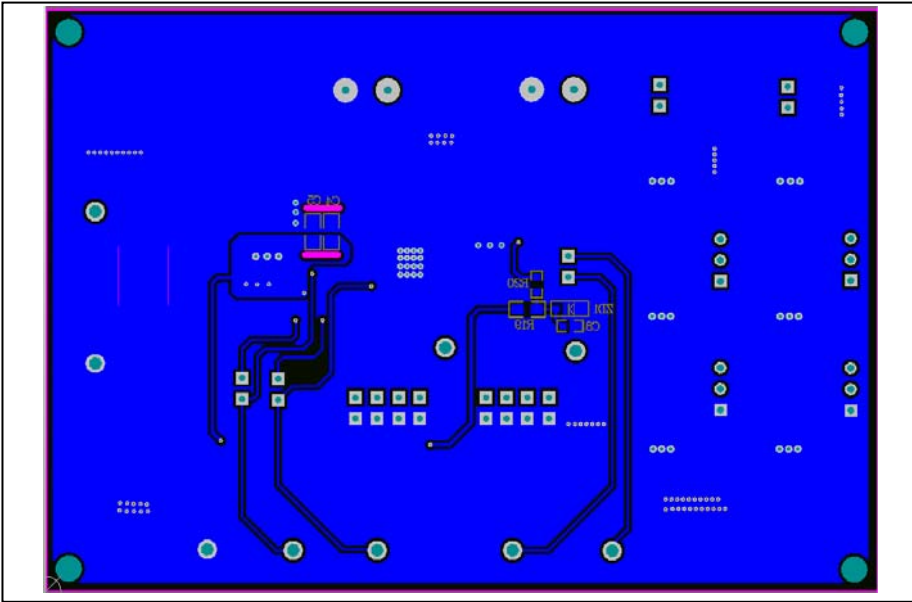

Figure 9 Board PCB Layout - Bottom Layer

Copyright © 2018 Integrated Silicon Solution, Inc. All rights reserved. ISSI reserves the right to make changes to this specification and its products at any time without notice. ISSI assumes no liability arising out of the application or use of any information, products or services described herein. Customers are advised to obtain the latest version of this device specification before relying on any published information and before placing orders for products.

Integrated Silicon Solution, Inc. does not recommend the use of any of its products in life support applications where the failure or malfunction of the product can reasonably be expected to cause failure of the life support system or to significantly affect its safety or effectiveness. Products are not authorized for use in such applications unless Integrated Silicon Solution, Inc. receives written assurance to its satisfaction, that:

- a.) the risk of injury or damage has been minimized;
- b.) the user assume all such risks; and
- c.) potential liability of Integrated Silicon Solution, Inc is adequately protected under the circumstances



**IS32LT3126 150MA DUAL CHANNEL LED DRIVER
WITH FAULT DETECTION**

REVISION HISTORY

Revision	Detail Information	Date
A	Initial release	2018.11.09

Данный компонент на территории Российской Федерации

Вы можете приобрести в компании MosChip.

Для оперативного оформления запроса Вам необходимо перейти по данной ссылке:

<http://moschip.ru/get-element>

Вы можете разместить у нас заказ для любого Вашего проекта, будь то серийное производство или разработка единичного прибора.

В нашем ассортименте представлены ведущие мировые производители активных и пассивных электронных компонентов.

Нашей специализацией является поставка электронной компонентной базы двойного назначения, продукции таких производителей как XILINX, Intel (ex.ALTERA), Vicor, Microchip, Texas Instruments, Analog Devices, Mini-Circuits, Amphenol, Glenair.

Сотрудничество с глобальными дистрибьюторами электронных компонентов, предоставляет возможность заказывать и получать с международных складов практически любой перечень компонентов в оптимальные для Вас сроки.

На всех этапах разработки и производства наши партнеры могут получить квалифицированную поддержку опытных инженеров.

Система менеджмента качества компании отвечает требованиям в соответствии с ГОСТ Р ИСО 9001, ГОСТ РВ 0015-002 и ЭС РД 009

Офис по работе с юридическими лицами:

105318, г.Москва, ул.Щербаковская д.3, офис 1107, 1118, ДЦ «Щербаковский»

Телефон: +7 495 668-12-70 (многоканальный)

Факс: +7 495 668-12-70 (доб.304)

E-mail: info@moschip.ru

Skype отдела продаж:

moschip.ru

moschip.ru_4

moschip.ru_6

moschip.ru_9