

### 3.5 mm×2.9 mm SMD Light Touch Switches

Type: **EVPA**A

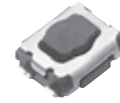

#### ■ Features

- External dimensions : 3.5 mm×2.9 mm, Height 1.7 mm
- High operating force available  
(Operating force : 7.0 N max.)
- Optional ground terminal

#### ■ Recommended Applications

- Operation switches for portable electronic equipments  
(Mobile phones, Digital still cameras, etc.)
- Operating switches for keyless entry systems

#### ■ Explanation of Part Numbers

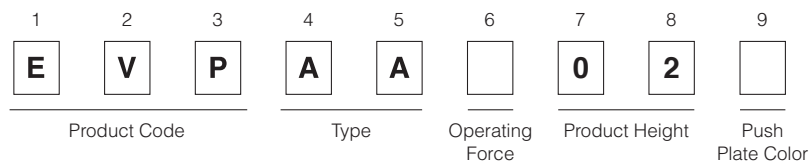

#### ■ Specifications

Type		Snap action/Push-on type SPST
Electrical	Rating	10 μA 2 V DC to 20 mA 15 V DC (Resistive load)
	Contact Resistance	100 mΩ max.
	Insulation Resistance	100 MΩ min. (at 100 V DC)
	Dielectric Withstanding Voltage	250 V AC for 1 minute
	Bouncing	10 ms max. (ON, OFF)
Mechanical	Operating Force	1.0 N, 1.6 N, 2.4 N, 3.5 N, 5.0 N, 7.0 N
	Travel	0.15 mm±0.1 mm
Endurance	Operating Life	1,000,000 cycles min. (1.0 N) 500,000 cycles min. (3.5 N) 200,000 cycles min. (1.6 N, 2.4 N, 3.5 N) 100,000 cycles min. (5.0 N, 7.0 N)
Operating Temperature		-40 °C to +85 °C
Storage Temperature		-40 °C to +85 °C (Bulk) -20 °C to +60 °C (Taping)
Minimum Quantity/Packing Unit		5,000 pcs. Embossed Taping (Reel Pack)
Quantity/Carton		25,000 pcs.

Note: Non washable

Design and specifications are each subject to change without notice. Ask factory for the current technical specifications before purchase and/or use.  
Should a safety concern arise regarding this product, please be sure to contact us immediately.

■ Dimensions in mm (not to scale)

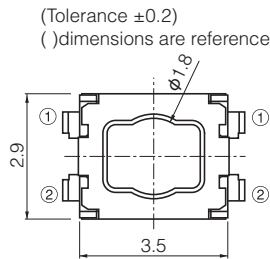
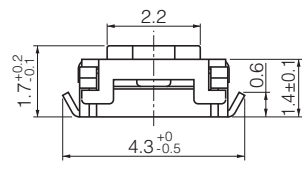
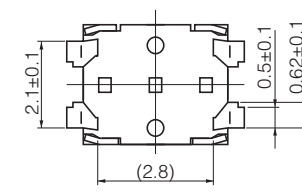
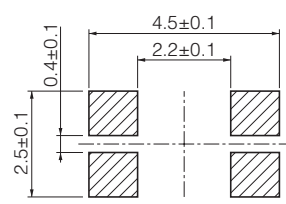
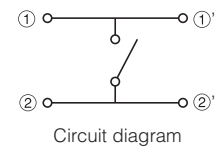
<p>No. 1</p> <p><b>EVPAA</b></p> <p>(Embossed Taping)          Thickness : 1.7 mm          With J-bent terminals          Without          Ground Terminal</p> 	<p>(Tolerance <math>\pm 0.2</math>)          ( ) dimensions are reference dimensions.</p>      <p>Circuit diagram</p> <p>PWB land pattern for reference</p>			
<p>Part Numbers</p>	<p>Ground Terminal</p>	<p>Operating Force</p>	<p>Push Plate Color</p>	<p>Operating Life</p>
<p>EVPA002K</p>	<p>Without</p>	<p>1.0 N</p>	<p>Black</p>	<p>1,000,000 cycles</p>
<p>EVPA202K</p>	<p>Without</p>	<p>1.6 N</p>	<p>Black</p>	<p>200,000 cycles</p>
<p>EVPA402W</p>	<p>Without</p>	<p>2.4 N</p>	<p>White</p>	<p>200,000 cycles</p>
<p>EVPA602W</p>	<p>Without</p>	<p>3.5 N</p>	<p>White</p>	<p>200,000 cycles</p>
<p>EVPAAM02W</p>	<p>Without</p>	<p>3.5 N</p>	<p>White</p>	<p>500,000 cycles</p>
<p>EVPA802Q</p>	<p>Without</p>	<p>5.0 N</p>	<p>Gray</p>	<p>100,000 cycles</p>
<p>EVPAAN02Q</p>	<p>Without</p>	<p>5.0 N</p>	<p>Gray</p>	<p>100,000 cycles (High load : 10N)</p>
<p>EVPAAU02Q</p>	<p>Without</p>	<p>7.0 N</p>	<p>Gray</p>	<p>100,000 cycles</p>

Design and specifications are each subject to change without notice. Ask factory for the current technical specifications before purchase and/or use.  
 Should a safety concern arise regarding this product, please be sure to contact us immediately.

■ Dimensions in mm (not to scale)

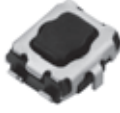
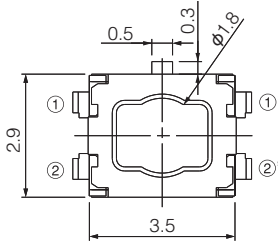
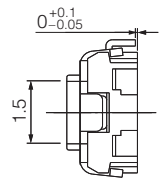
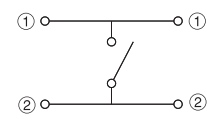
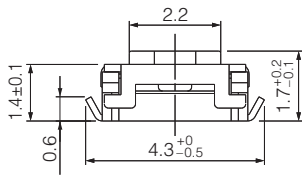
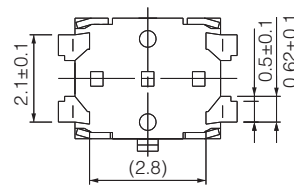
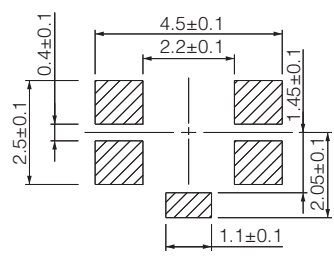
<p>No. 2</p> <p><b>EVPAA</b></p> <p>(Embossed Taping) Thickness : 1.7 mm With J-bent terminals With Ground Terminal</p> 	<p>(Tolerance <math>\pm 0.2</math>) ( ) dimensions are reference dimensions.</p>			
			 <p>Circuit diagram</p>	
				
		 <p>PWB land pattern for reference</p>		
Part Numbers	Ground Terminal	Operating Force	Push Plate Color	Operating Life
EVPAA102K	With	1.0 N	Black	1,000,000 cycles
EVPAA302K	With	1.6 N	Black	200,000 cycles
EVPAA502W	With	2.4 N	White	200,000 cycles
EVPAA702W	With	3.5 N	White	200,000 cycles
EVPAAQ02W	With	3.5 N	White	500,000 cycles
EVPAA902Q	With	5.0 N	Gray	100,000 cycles
EVPAAR02Q	With	5.0 N	Gray	100,000 cycles (High load : 10N)

Design and specifications are each subject to change without notice. Ask factory for the current technical specifications before purchase and/or use.  
Should a safety concern arise regarding this product, please be sure to contact us immediately.

## ■ Recommended Reflow Soldering Conditions

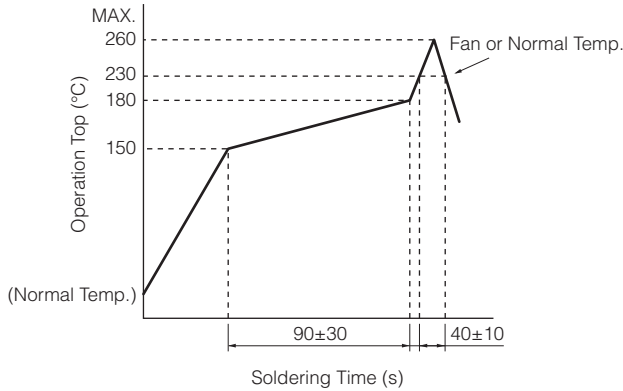

## ● Embossed Carrier Taping

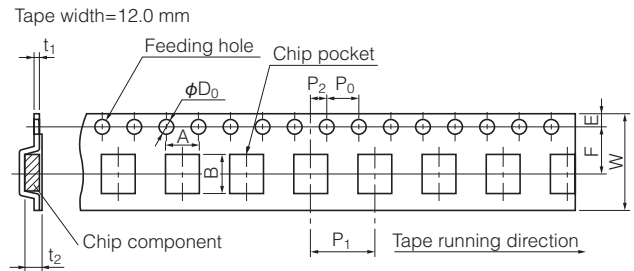

Taping condition : Lack of products in the middle of taping should be one MAX, but total quantity specified in the specifications should be secured.  
 Peeling off strength of top tape : It should be within 0.2N to 1.0N at 165 degree in peeling off angle.  
 Joint of carrier tape : One joint per one reel may exist.

Unit: mm

Part No.	Height	A	B	W	F	E	P <sub>1</sub>	P <sub>2</sub>	P <sub>0</sub>	D <sub>0</sub> Dia	t <sub>1</sub>	t <sub>2</sub>
EVPAA	1.7	4.5±0.2	3.8±0.2	12.0±0.3	5.5±0.1	1.75±0.10	8.0±0.1	2.0±0.1	4.0±0.1	1.5 <sup>+0.1</sup>	0.3±0.1	1.85±0.20

## ■ Recommended Shape of Test Pole

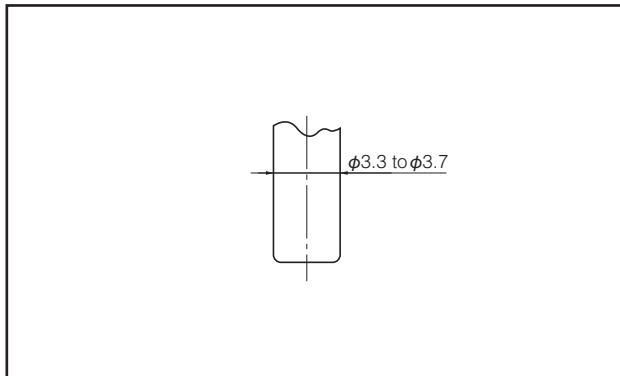

## ■ Recommended Operating Conditions

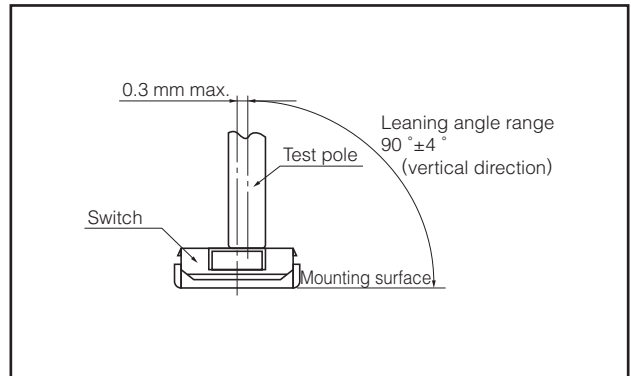

Design and specifications are each subject to change without notice. Ask factory for the current technical specifications before purchase and/or use.  
 Should a safety concern arise regarding this product, please be sure to contact us immediately.

# Mouser Electronics

Authorized Distributor

Click to View Pricing, Inventory, Delivery & Lifecycle Information:

## Panasonic:

[EVP-AA102K](#) [EVP-AA302K](#) [EVP-AA502W](#) [EVP-AA702W](#) [EVP-AA902Q](#) [EVP-AA002K](#) [EVP-AA202K](#) [EVP-AA402W](#) [EVP-AA602W](#) [EVP-AA802Q](#) [EVP-AAM02W](#) [EVP-AAN02Q](#) [EVP-AAU02Q](#) [EVP-AAQ02W](#) [EVP-AAR02Q](#)

## Данный компонент на территории Российской Федерации

### Вы можете приобрести в компании MosChip.

Для оперативного оформления запроса Вам необходимо перейти по данной ссылке:

<http://moschip.ru/get-element>

Вы можете разместить у нас заказ для любого Вашего проекта, будь то серийное производство или разработка единичного прибора.

В нашем ассортименте представлены ведущие мировые производители активных и пассивных электронных компонентов.

Нашей специализацией является поставка электронной компонентной базы двойного назначения, продукции таких производителей как XILINX, Intel (ex.ALTERA), Vicor, Microchip, Texas Instruments, Analog Devices, Mini-Circuits, Amphenol, Glenair.

Сотрудничество с глобальными дистрибьюторами электронных компонентов, предоставляет возможность заказывать и получать с международных складов практически любой перечень компонентов в оптимальные для Вас сроки.

На всех этапах разработки и производства наши партнеры могут получить квалифицированную поддержку опытных инженеров.

Система менеджмента качества компании отвечает требованиям в соответствии с ГОСТ Р ИСО 9001, ГОСТ РВ 0015-002 и ЭС РД 009

### Офис по работе с юридическими лицами:

105318, г.Москва, ул.Щербаковская д.3, офис 1107, 1118, ДЦ «Щербаковский»

Телефон: +7 495 668-12-70 (многоканальный)

Факс: +7 495 668-12-70 (доб.304)

E-mail: [info@moschip.ru](mailto:info@moschip.ru)

Skype отдела продаж:

moschip.ru

moschip.ru\_4

moschip.ru\_6

moschip.ru\_9