

DIO8850D

Single Stage Buck PFC Controller for LED Lighting

Features

- Valley turn-on of the MOSFET to achieve low switching losses
- 0.3V current sense reference voltage leads to a lower sense resistance thus a lower conduction loss
- Low start up current: 15μA typical
- Reliable short LED and Open LED protection
- Power factor >0.9
- Compact package: SOT23-6, SOIC-8

Descriptions

The DIO8850D is a single stage Buck PFC controller targeting at LED lighting applications. It drives the Buck converter in the quasi-resonant mode to achieve higher efficiency.

It keeps the Buck converter inconstant on time operation to achieve high power factor.

Applications

- LED Lighting
- Down light
- Tube lamp & PAR lamp & Bulb lamp

Block Diagram

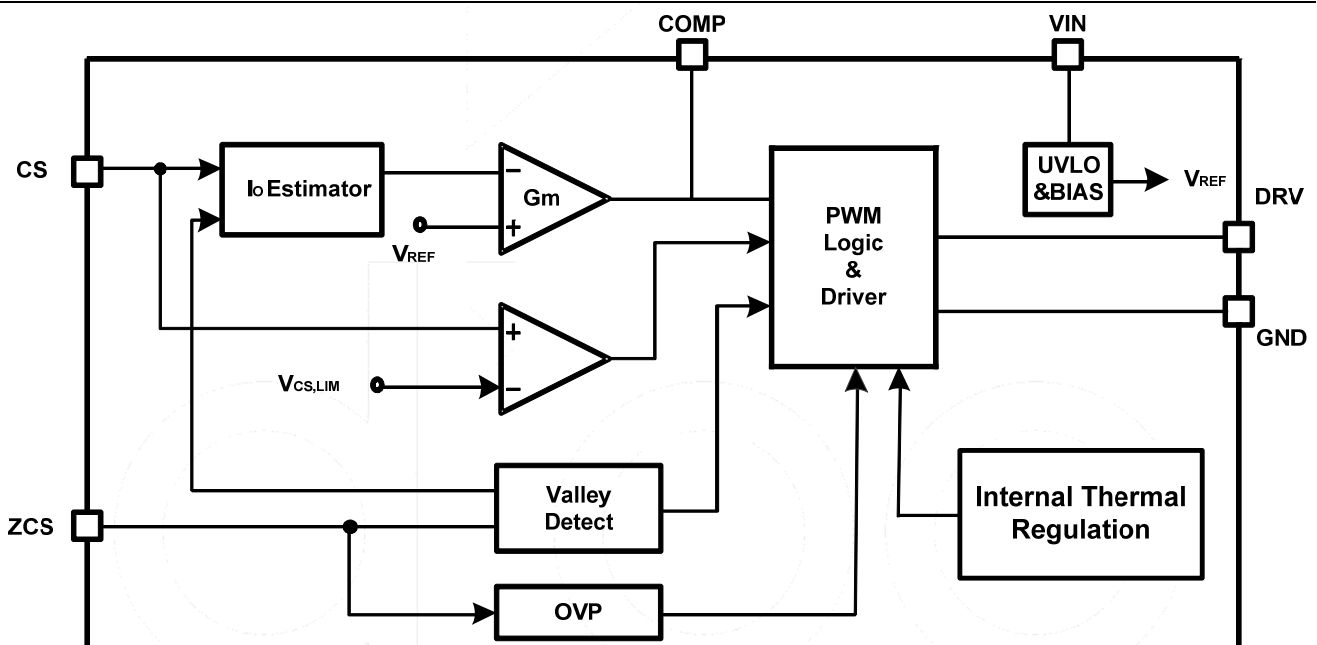

Figure1 Block Diagram

Ordering Information

Order Part Number	Top Marking		T _A	Package	
DIO8850DCST6	YW8D	Green	-40 to +85°C	SOT23-6	Tape & Reel, 3000
DIO8850DCS8	DIO8850D	Green	-40 to +85°C	SOIC-8	Tape & Reel, 2500

Pin Assignments

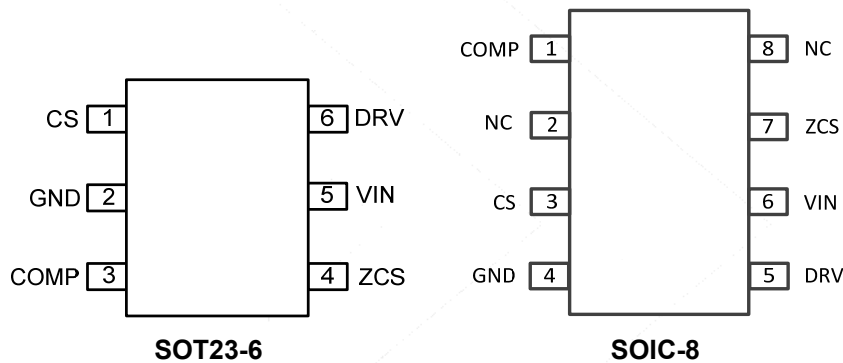
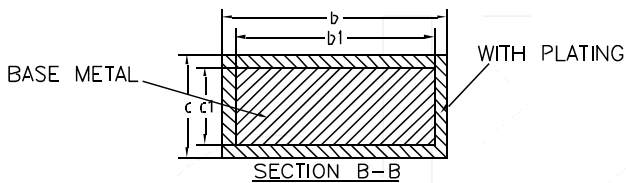
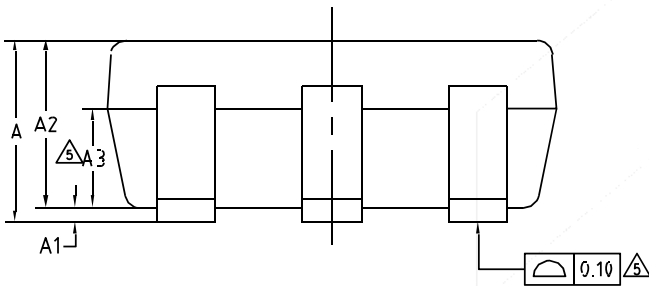
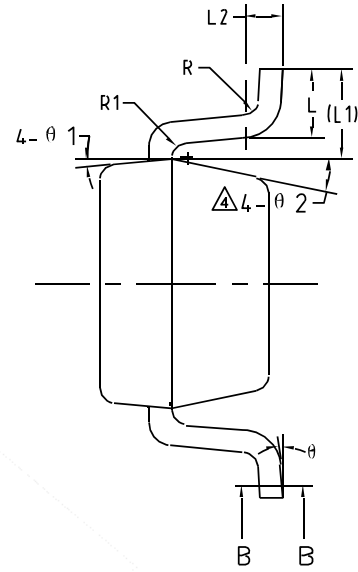
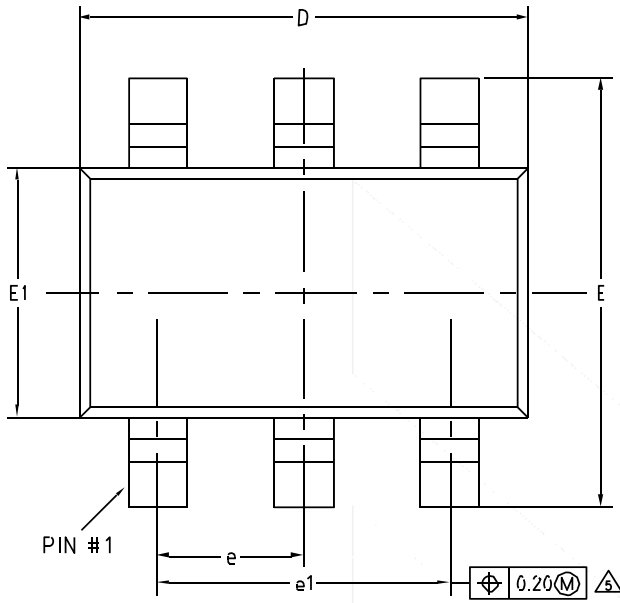

Figure 2 Pin Assignment (Top View)

Pin Definitions

Pin Name	Description
CS	Current sense pin. Connect this pin to the source of the primary switch. Connect the sense resistor across the source of the primary switch and the GND pin. (current sense resistor Resistor: $R_s = \frac{1}{2} \times \frac{V_{ref}}{I_{out}}$) Also this pin used to detect transformer and secondary is short or not.
GND	Ground pin
COMP	Loop compensation pin. Connect a RC network across this pin and ground to stabilize the control loop.
ZCS	Inductor current zero-crossing detection pin. This pin receives the auxiliary winding voltage by a resistor divider and detects the inductor current zero crossing point. This pin also provides over voltage protection and line regulation modification function simultaneously. If the voltage on this pin is above $V_{ZCS,OV}$, the IC would enter overvoltage protection mode. Good line regulation can be achieved by adjusting the upper resistor of the divider.
VIN	Power supply pin. This pin also provides output over voltage protection along with ZCS pin.
DRV	Gate driver pin. Connect this pin to the gate of primary MOSFET.
NC	Not Connect.

Physical Dimensions: SOT-23-6



COMMON DIMENSIONS (UNITS OF MEASURE=MILLIMETER)			
Symbol	MIN	NOM	MAX
A	-	-	1.25
A1	0	-	0.15
A2	1.00	1.10	1.20
A3	0.60	0.65	0.70
b	0.36	-	0.50
b1	0.36	0.38	0.45
c	0.14	-	0.20
c1	0.14	0.15	0.16
D	2.826	2.926	3.026
E	2.60	2.80	3.00
E1	1.526	1.626	1.726
e	0.90	0.95	1.00
e1	1.80	1.90	2.00
L	0.35	0.45	0.60
L1	0.59REF		
L2	0.25BSC		
R	0.10	-	-
R1	0.10	-	0.25
Θ	0°	-	8°
Θ1	3°	5°	7°
Θ2	6°	-	14°

Physical Dimensions: SOIC-8

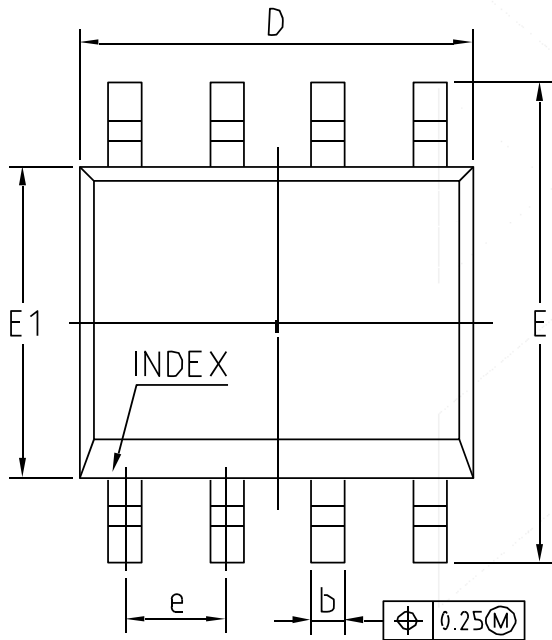
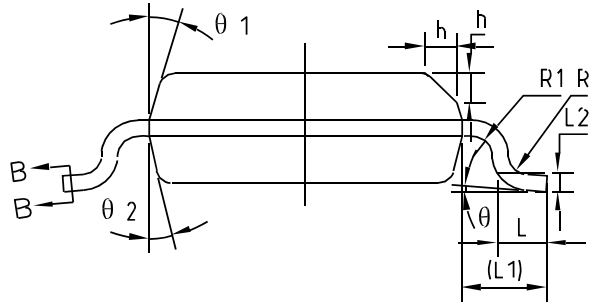
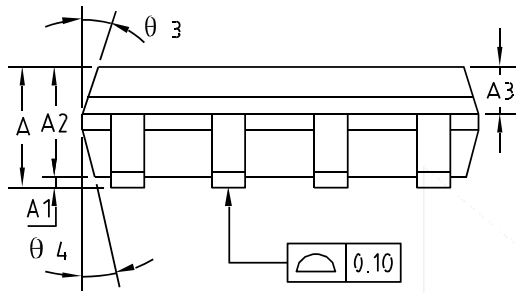

COMMON DIMENSIONS (UNITS OF MEASURE=MILLIMETER)			
Symbol	MIN	NOM	MAX
A	1.35	1.55	1.75
A1	0.10	0.15	0.25
A2	1.25	1.40	1.65
A3	0.50	0.60	0.70
b	0.38	-	0.51
b1	0.37	0.42	0.47
c	0.17	-	0.25
c1	0.17	0.20	0.23
D	4.80	4.90	5.00
E	5.80	6.00	6.20
E1	3.80	3.90	4.00
e	1.27BSC		
L	0.45	0.60	0.80
L1	1.04REF		
L2	0.25BSC		
R	0.07	-	-
R1	0.07	-	-
h	0.30	0.40	0.50
θ	0°	-	8°
θ1	15°	17°	19°
θ2	11°	13°	15°
θ3	15°	17°	19°
θ4	11°	13°	15°

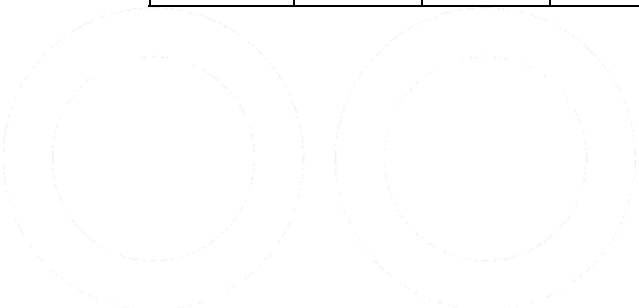
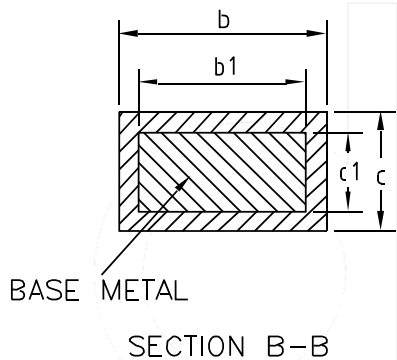



DIO8850D

Single Stage Buck PFC Controller For LED Lighting

CONTACT US

Dioo is a professional design and sales corporation for high-quality and performance analog semiconductors. The company focuses on industry markets, such as, cell phone, handheld products, laptop, and medical equipment and so on. Dioo's product families include analog signal processing and amplifying, LED drivers and charger IC. Go to <http://www.dioo.com> for a complete list of Dioo product families.

For additional product information, or full datasheet, please contact with our Sales Department or Representatives.



Данный компонент на территории Российской Федерации

Вы можете приобрести в компании MosChip.

Для оперативного оформления запроса Вам необходимо перейти по данной ссылке:

<http://moschip.ru/get-element>

Вы можете разместить у нас заказ для любого Вашего проекта, будь то серийное производство или разработка единичного прибора.

В нашем ассортименте представлены ведущие мировые производители активных и пассивных электронных компонентов.

Нашей специализацией является поставка электронной компонентной базы двойного назначения, продукции таких производителей как XILINX, Intel (ex.ALTERA), Vicor, Microchip, Texas Instruments, Analog Devices, Mini-Circuits, Amphenol, Glenair.

Сотрудничество с глобальными дистрибьюторами электронных компонентов, предоставляет возможность заказывать и получать с международных складов практически любой перечень компонентов в оптимальные для Вас сроки.

На всех этапах разработки и производства наши партнеры могут получить квалифицированную поддержку опытных инженеров.

Система менеджмента качества компании отвечает требованиям в соответствии с ГОСТ Р ИСО 9001, ГОСТ РВ 0015-002 и ЭС РД 009

Офис по работе с юридическими лицами:

105318, г.Москва, ул.Щербаковская д.3, офис 1107, 1118, ДЦ «Щербаковский»

Телефон: +7 495 668-12-70 (многоканальный)

Факс: +7 495 668-12-70 (доб.304)

E-mail: info@moschip.ru

Skype отдела продаж:

moschip.ru

moschip.ru_4

moschip.ru_6

moschip.ru_9