

LSCR SERIES HIGH-SPEED FUSE BLOCKS

700 V/1000 V



Description

Littelfuse LSCR Series is a comprehensive line of modular fuse blocks, designed to accommodate a wide range of High-Speed and UL Power Fuses. These LSCR Series blocks have modular stud type design that enables easy mounting in panel boards.

LSCR Series blocks are CE Certified and RoHS Compliant.

Features/Benefits

- Modular design reduces inventory requirements
- Sold in pairs for convenience
- Supplied with nut and belleville washer
- 200kA Short-circuit withstand rating
- Constructed of molded phenolic (with plated steel studs) provide greater heat dissipation

Specifications

Voltage Rating	700 V / 1000 V
Ampere Ratings	400A, 800A and 1200A
Withstand Rating	200kA
Approvals	UL Recognized (File: E14721) cURus Recognized (E14721) CSA Certified (File: 73160)
Material	Base: Molded Phenolic or Thermoplastic Terminal Construction: Plated steel.
Flammability Rating	UL94 V-0
Environmental	RoHS Compliant
Country of Origin	LSCR0xx - China LSCR1xx - USA

Web Resources

For more information, visit: littelfuse.com/lscr

Electrical & Mechanical Specifications

CATALOG/ ORDERING NUMBER	AMPERE RATING	VOLTAGE RATING	TERMINAL (STUD) MATERIAL	INSULATOR		TERMINAL (STUD) SIZE	STUD TORQUE		MOUNTING FASTNER SIZE	FASTENER TORQUE		AGENCY APPROVALS		
				MATERIAL	MAX. BASE TEMPERATURE		(in.lbs)	(N-m)		(in.lbs)	(N-m)	UR	CURUS	CSA
LSCR001	400A	700Vac/dc	Plated Steel	Molded Phenolic	150°C (302°F)	¼-20 UNC	61	6.9	#10	20-25	2.3-2.8	•		•
LSCR002	800A	700Vac/dc	Plated Steel	Molded Phenolic	150°C (302°F)	3/8-16 UNC	192	21.7	#10	20-25	2.3-2.8	•		•
LSCR101	400A	1000Vac/dc	Steel, Zinc Plated	Thermoplastic	125°C (257°F)	¼-20 UNC	75	8.5	#10	25-30	2.8-3.4		•	
LSCR102	800A	1000Vac/dc	Steel, Zinc Plated	Thermoplastic	125°C (257°F)	3/8-16 UNC	230	26	#10	25-30	2.8-3.4		•	
LSCR103	1200A	1000Vac/dc	Steel, Zinc Plated	Thermoplastic	125°C (257°F)	½-13 UNC	300	34	¼"	25-30	2.8-3.4		•	

LSCR SERIES HIGH-SPEED FUSE BLOCKS

Dimensions mm (inches)

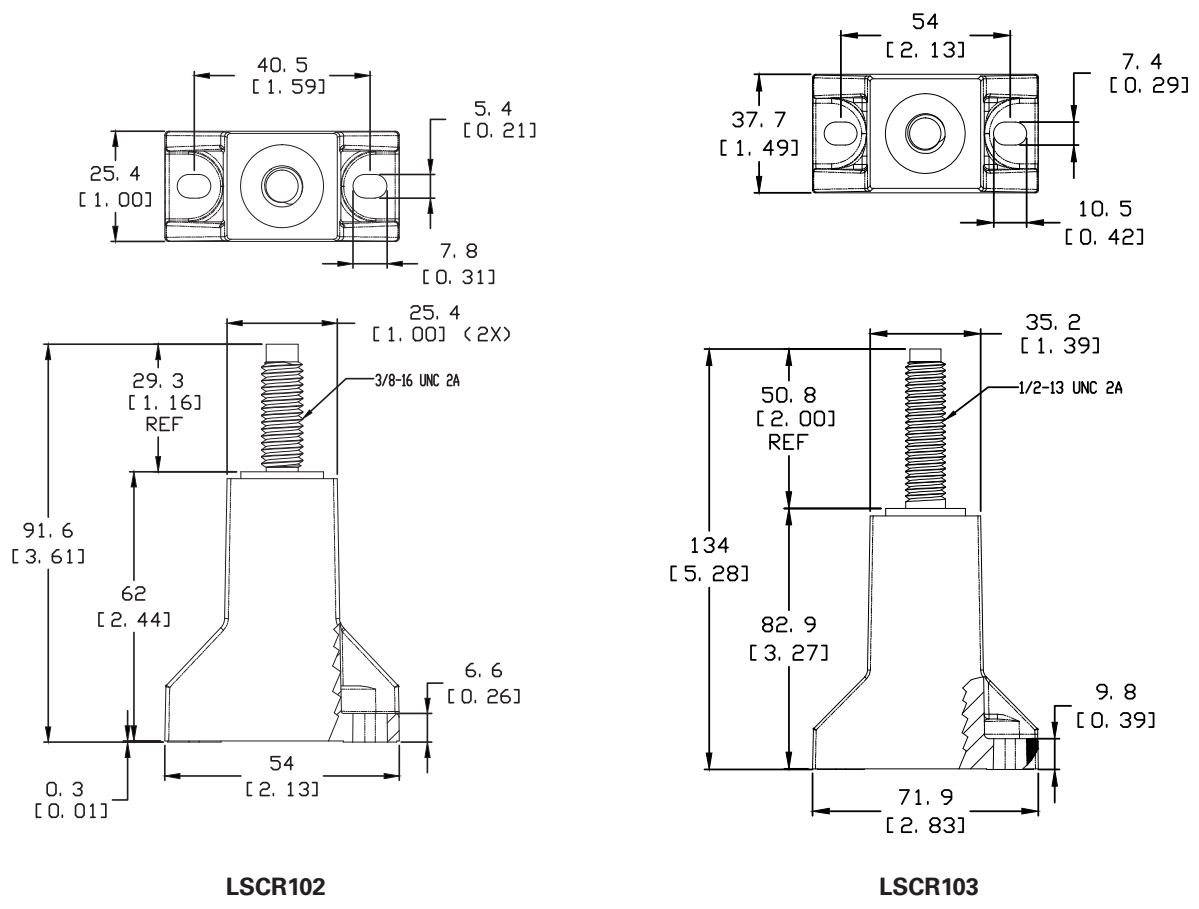
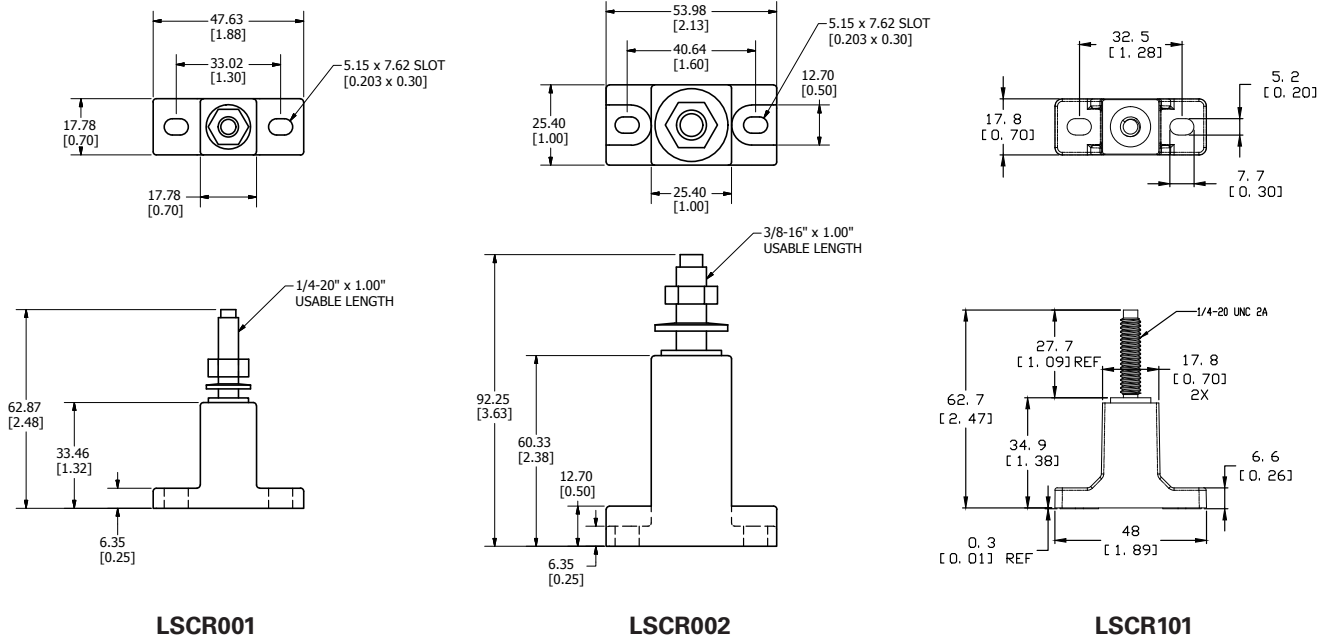

LSCR SERIES HIGH-SPEED FUSE BLOCKS

High-Speed Fuse Block Selection Guide

FUSE SERIES	CATALOG NUMBER	LSCR001	LSCR002	LSCR101	LSCR102	LSCR103
	TERMINAL SIZE	1/4 - 20 UNC	3/8 - 16 UNC	1/4 - 20 UNC	3/8 - 16 UNC	1/2 - 13 UNC
	VOLTAGE RATING	700Vac/dc	700Vac/dc	1000Vac/dc	1000Vac/dc	1000Vac/dc
	AMPERE RATING	400A	800A	400A	800A	1200A
L15S	70-400	X		X		
	500-800		X		X	
L17T	70-250	X		X		
	300-800		X		X	
L25S	35-200	X		X		
	225-800		X		X	
L50S	35-200	X		X		
	225-800		X		X	
	700-800					X
L50QS	35-200	X		X		
	225-800		X		X	
	700-800					X
L60S	35-200	X		X		
	225-800		X		X	
	700-800					X
KLC	35-60	X		X		
	70-800		X		X	
	225-800					X
L70S	35-100	X		X		
	125-800		X		X	
	450-800					X
L70QS	35-100	X		X		
	125-800		X		X	
	450-800					X
JLLN	70-200	X		X		
	225-800		X		X	
	700-1200					X
JLLS	70-200	X		X		
	225-800		X		X	
	700-1200					X
JLS	70-100	X		X		
	110-200	X		X		
	225-400		X		X	
SPFJ	450-600		X		X	
	70-100			X		
	125-200			X		
L75QS	250-400				X	
	450					X
	35-100			X		
L75QS	125-800				X	
	450-800					X

Disclaimer Notice – Information furnished is believed to be accurate and reliable. However, users should independently evaluate the suitability of and test each product selected for their own applications. Littelfuse products are not designed for, and may not be used in, all applications. Read complete Disclaimer Notice at www.littelfuse.com/product-disclaimer.

Данный компонент на территории Российской Федерации

Вы можете приобрести в компании MosChip.

Для оперативного оформления запроса Вам необходимо перейти по данной ссылке:

<http://moschip.ru/get-element>

Вы можете разместить у нас заказ для любого Вашего проекта, будь то серийное производство или разработка единичного прибора.

В нашем ассортименте представлены ведущие мировые производители активных и пассивных электронных компонентов.

Нашей специализацией является поставка электронной компонентной базы двойного назначения, продукции таких производителей как XILINX, Intel (ex.ALTERA), Vicor, Microchip, Texas Instruments, Analog Devices, Mini-Circuits, Amphenol, Glenair.

Сотрудничество с глобальными дистрибьюторами электронных компонентов, предоставляет возможность заказывать и получать с международных складов практически любой перечень компонентов в оптимальные для Вас сроки.

На всех этапах разработки и производства наши партнеры могут получить квалифицированную поддержку опытных инженеров.

Система менеджмента качества компании отвечает требованиям в соответствии с ГОСТ Р ИСО 9001, ГОСТ РВ 0015-002 и ЭС РД 009

Офис по работе с юридическими лицами:

105318, г.Москва, ул.Щербаковская д.3, офис 1107, 1118, ДЦ «Щербаковский»

Телефон: +7 495 668-12-70 (многоканальный)

Факс: +7 495 668-12-70 (доб.304)

E-mail: info@moschip.ru

Skype отдела продаж:

moschip.ru

moschip.ru_4

moschip.ru_6

moschip.ru_9