

FNF-LT11x

Front Load Pluggable Optical Transceiver

The FNF-LT11 multimode glass optical fiber transceivers provide low profile, cost effective solutions for Fast Ethernet multimode (up to 2.0 km) optical fiber data links with a duplex LC connector interface. These transceivers are fully compliant with the IEEE 802.3u Fast Ethernet standard but can be used for any other data communications purpose within their operating parameters.

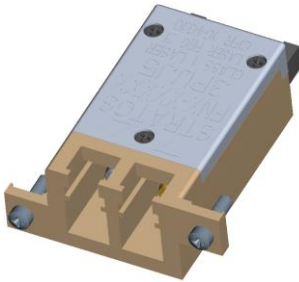

This transceiver consist of transmitter and receiver functions combined in a Low Profile module. The optical transmitter is a high output 1310 nm LED. The transmitter input lines are driven with differential LVPECL signals applied to the Transmit (TX+ and TX-) pins. These signals are internally converted to a suitable modulation current by a CMOS integrated circuit.

The optical receivers consist of PIN and Preamplifier assemblies and CMOS limiting post-amplifier integrated circuits. Outputs from the receivers consist of differential CML data signals on the Receive (RX+ and RX-) pins and a single ended LVTTTL loss of signal function on Loss of Signal (LOS) pin. The RX data is squelched (JAM) upon LOS Assert to prevent garbage data output when no optical signal is present

Key Features & Benefits

- Fast Ethernet Applications, up to 2.0 km
- 3.3 V, 1310 nm, LED, Multimode
- Front load pluggable miniature transceiver
- MSA height, but half the footprint
- MSA compliant Digital Diagnostics
- Surface Mount I/O pins for high speed signal integrity
- Industrial Temp Range, Vibration tolerant design
- Individual (separate) +3.3 V power supply per port
- Industry standard duplex multimode LC receptacle
- Full compliance to IEEE 802.3u Fast Ethernet
- EN-60825 / IEC-825 / CDRH Class 1 Compliant

1. ORDERING INFORMATION

F	N	F	-LT11	H
F = Front Load Low Rider	N = No GND tabs	F = Fast Ethernet	LT11 = MM 1310 nm	H = No conf coat M = Conf coat

2. ABSOLUTE MAXIMUM RATINGS

Absolute maximum limits mean that no catastrophic damage will occur if the product is subjected to these ratings for short periods, provided each limiting parameter is in isolation and all other parameters have values within the performance specification. It should not be assumed that limiting values of more than one parameter can be applied to the product at the same time.

PARAMETER	SYMBOL	MIN	TYPICAL	MAX	UNIT
Storage Temperature	T_s	-55		+100	°C
Lead Hand Soldering Temperature ¹	T_{SOLD}			+260	°C
Lead Soldering Time ¹	t_{SOLD}			10	Second
Supply Voltage	V_{CC}	-0.5		+4.5	V
Data Input Voltage	V_i	-0.5		V_{CC}	V
Differential Input Voltage (p-p)	V_D			2.0	V
Output Current	I_o			50	mA

¹ The Front Load Pluggable Optical Transceiver is not soldered, rather it is the Cage and Connector that are soldered to the application card. Therefore, these Solder specifications apply only for the Cage and Connector

3. RECOMMENDED OPERATING CONDITIONS

PARAMETER	SYMBOL	MIN	TYPICAL	MAX	UNIT
Operating Temperature Limit	T_A	-40		+85	°C
Supply Voltage	V_{CC}	+3.135		+3.465	V
Tx Common Mode Voltage	V_{CM}		2.0		V
Tx Differential Input Voltage (p-p)	V_D	0.35		1.25	V
Rx Data Output Load	R_L		50		W

4. TRANSMITTER

PARAMETER ²	SYMBOL	MIN	TYPICAL	MAX	UNIT
Optical Output Power ¹	P_O	-20.0		-14.0	dBm
Optical Output Wavelength	λ_{OUT}	1285	1310	1360	nm
Spectral Width (RMS)	$\Delta\lambda_{RMS}$			63	nm
Spectral Width (FWHM)	$\Delta\lambda_{FWHM}$			175	nm
Extinction Ratio	ER	12			dB
Supply Current	I_{CC}		120	160	mA
Optical Rise/Fall Time (20% - 80%)	$t_{R,F}$			3.0	ns

¹ BER = 10^{-10} @ 125 Mbps, PRBS 2⁷-1, NRZ, Compliant with FDDI PMD ISO / IEC 9314-3 and IEEE 802.3u testing with 62.5 MM fiber

² V_{CC} Tx = 3.15 – 3.45 V, T_A = Operating temperature range

5. RECEIVER

PARAMETER	SYMBOL	MIN	TYPICAL	MAX	UNIT
Optical Sensitivity ¹	P _I	-32.0		-8.0	dBm
Optical Wavelength	λ _{IN}	1260		1380	nm
Supply Current	I _{CC}		70	120	mA
Loss of Signal Assert Time	T _{LOSAS}		<10	100	μs
Loss of Signal Deassert Time	T _{LOSBS}		<10	350	μs
Loss of Signal Threshold ²					
Decreasing Light	LSTD	-45.0		-32.5	dBm
Increasing Light	LSTI	-45.0		-32.0	dBm
Loss of Signal Hysteresis	HYS	0.5	2.25	3.5	dB
Rx Data Output – Low	V _{OL} -V _{CC}	-1.810		-1.475	V
Rx Data Output – High	V _{OH} -V _{CC}	-1.165		-0.880	V

¹ BER = 10⁻¹⁰ @ 125 Mbps, PRBS 2⁷-1, NRZ, Compliant with FDDI PMD ISO / IEC 9314-3 and IEEE 802.3u testing with 62.5 MM fiber

² Rx Data output are squelched when Loss of Signal is asserted to prevent garbage data output when no optical signal is present

6. CONFORMAL COATING OPTION

PARAMETER	VALUE
Specification	MIL-I-46058C, Type XY
Coating	Parylene type C
Deposition	Vacuum deposited
Film Thickness	1 MIL +/- 0.0002"

7. LINK DISTANCES

APPLICATION	FIBER SPECIFICATION	DISTANCE
Fast Ethernet	62.5/125 – 500 MHz*km	2.0 km
IEEE 802.3u FDDI PMD ISO / IEC 9314-3	50/125 – 500 MHz*km	2.0 km

8. MECHANICAL DETAILS – FRONT LOADER

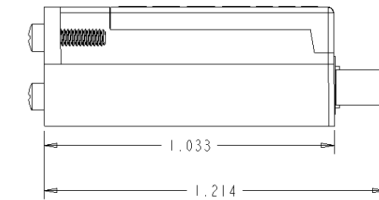
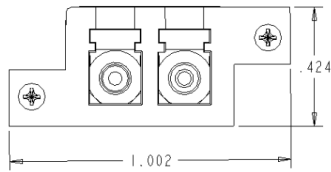
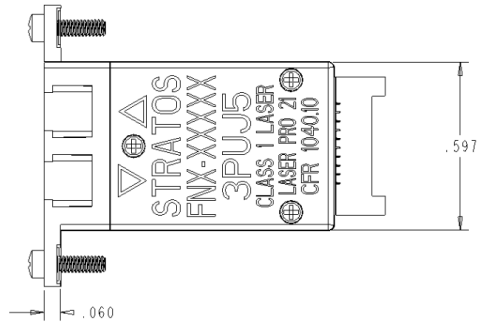
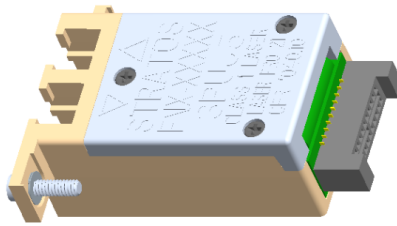

All dimensions in inches.
 All dimensions +/- 0.005", unless noted
 Screw torque 0.50 +/- 0.10 in-lbs

9. MECHANICAL DETAILS – FRONT LOADER CAGE

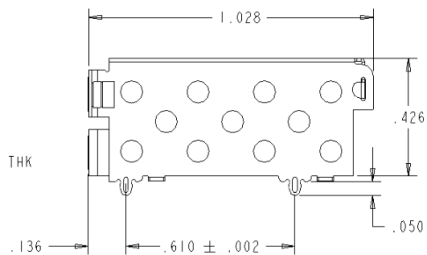
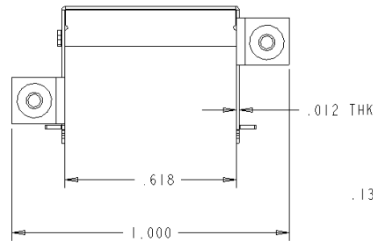
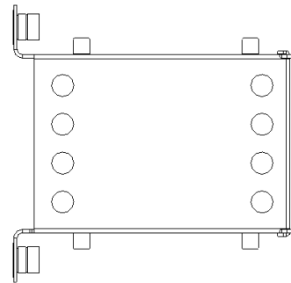
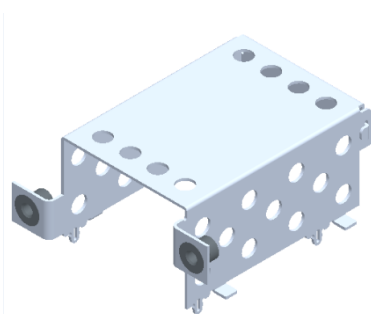

All dimensions in inches.
 All dimensions +/- 0.005", unless noted
 Screw torque 0.50 +/- 0.10 in-lbs

Данный компонент на территории Российской Федерации

Вы можете приобрести в компании MosChip.

Для оперативного оформления запроса Вам необходимо перейти по данной ссылке:

<http://moschip.ru/get-element>

Вы можете разместить у нас заказ для любого Вашего проекта, будь то серийное производство или разработка единичного прибора.

В нашем ассортименте представлены ведущие мировые производители активных и пассивных электронных компонентов.

Нашей специализацией является поставка электронной компонентной базы двойного назначения, продукции таких производителей как XILINX, Intel (ex.ALTERA), Vicor, Microchip, Texas Instruments, Analog Devices, Mini-Circuits, Amphenol, Glenair.

Сотрудничество с глобальными дистрибьюторами электронных компонентов, предоставляет возможность заказывать и получать с международных складов практически любой перечень компонентов в оптимальные для Вас сроки.

На всех этапах разработки и производства наши партнеры могут получить квалифицированную поддержку опытных инженеров.

Система менеджмента качества компании отвечает требованиям в соответствии с ГОСТ Р ИСО 9001, ГОСТ РВ 0015-002 и ЭС РД 009

Офис по работе с юридическими лицами:

105318, г.Москва, ул.Щербаковская д.3, офис 1107, 1118, ДЦ «Щербаковский»

Телефон: +7 495 668-12-70 (многоканальный)

Факс: +7 495 668-12-70 (доб.304)

E-mail: info@moschip.ru

Skype отдела продаж:

moschip.ru

moschip.ru_4

moschip.ru_6

moschip.ru_9