

Switching Driver with Regulator for Class-D Headphone Amplifier

■ GENERAL DESCRIPTION

The **NJU8715** is a switching driver with regulator for class-D headphone amplifier. It incorporates an optimum regulator for the driver of headphone amplifier, class-D line amplifier and a beep amplifier. The **NJU8715** converts 1bit digital signal of the PWM or the PDM to an analog signal output through a simple external LC low-pass filter.

The **NJU8715** provides a completed digital system and high power-efficiency with class-D operation. Therefore, it is suitable for portable audio applications.

■ PACKAGE OUTLINE



NJU8715KN1

■ FEATURES

- 2-channel 1bit Audio Signal Input
- Headphone Output
- Built-in Class D Line Amplifier
- Built-in Regulator for Driver
- Beep Function
- Logic Operating Voltage 1.9 to 2.6V (V_{DD})
- Regulator Operating Voltage 4.0 to 5.75V (V_G)
1.9 to 4.0V (V_{REG})
- C-MOS Technology
- Package Outline QFN28

■ PIN CONFIGURATION

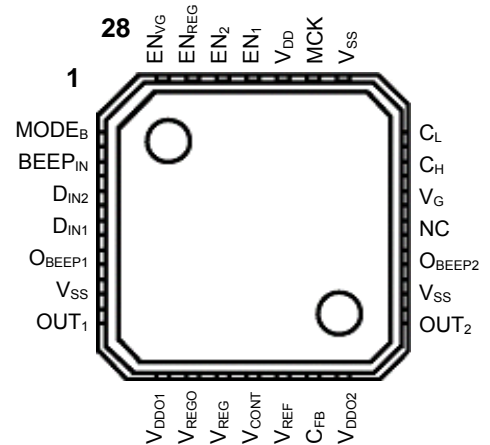

■ BLOCK DIAGRAM

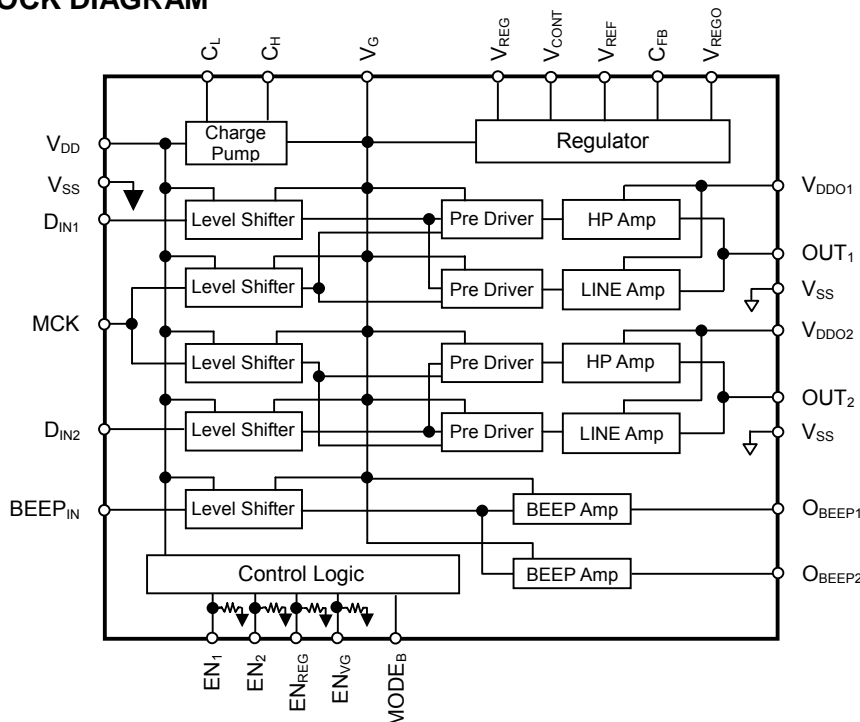

■ TERMINAL DESCRIPTION

No.	SYMBOL	I/O	Function
1	MODE _B	I	BEEP Output Level Control Terminal H: -39dBm, L: -48dBm The load of 16Ω (Note.1)
2	BEEP _{IN}	I	BEEP Signal Input Terminal
3	D _{IN2}	I	Audio Signal Input Terminal 2
4	D _{IN1}	I	Audio Signal Input Terminal 1
5	O _{BEEP1}	O	BEEP Output Terminal 1
6, 16, 22	V _{SS}	-	Power GND: V _{SS} =0V (Note.2)
7	OUT ₁	O	Output Terminal 1 This terminal outputs D _{IN1} terminal input data.
8	V _{DDO1}	-	Driving Power Supply 1
9	V _{REGO}	O	Regulator Output Terminal
10	V _{REG}	I	Regulator Input Terminal
11	V _{CONT}	I	Regulator Output Voltage Control Terminal
12	V _{REF}	O	Reference Voltage Output Terminal
13	C _{FB}	I	Regulator Output Voltage Sense Terminal
14	V _{DDO2}	-	Driving Power Supply 2
15	OUT ₂	O	Output Terminal 2 This terminal outputs D _{IN2} terminal input data.
17	O _{BEEP2}	O	BEEP Output Terminal 2
18	NC	-	Non connection
19	V _G	-	Pre-driver Power supply
20	C _H	-	+ Capacitor Connection Terminal for the charge pump
21	C _L	-	- Capacitor Connection Terminal for the charge pump
23	MCK	I	Master Clock Input Terminal The condition of the data input terminal is latched on the rising edge of this signal.
24	V _{DD}	-	Operation Power Supply
25	EN ₁	I	HP/LINE/BEEP Mode Control Terminal 1 (with pull-down resistor)
26	EN ₂	I	HP/LINE/BEEP Mode Control Terminal 2 (with pull-down resistor)
27	EN _{REG}	I	Regulator Enable Terminal (with pull-down resistor) H : ON, L : OFF
28	EN _{VG}	I	Charging pump Enable Terminal (with pull-down resistor) H : ON, L : OFF

Note.1) 0dBm≒0.775Vrms

Note.2) V_{SS}(Terminal No.6,16,22) should be connected at the nearest point to the IC.

■ INPUT TERMINAL STRUCTURE

MCK, D_{IN1}, D_{IN2}, BEEP_{IN}, MODE_B Terminal

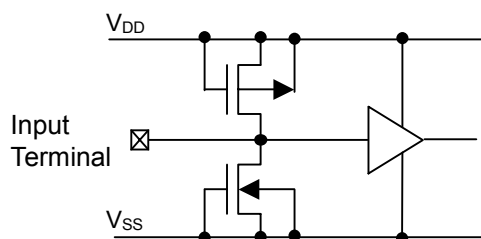

EN₁, EN₂, EN_{REG}, EN_{VG} Terminal

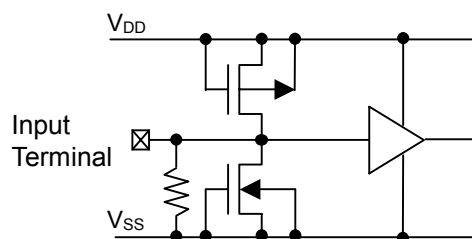

■ FUNCTIONAL DESCRIPTION

(1) Power Supply

V_{DD} : Power supply for input circuit and control logic. Keep the input logic level less than V_{DD} .

V_G : Power supply for pre-driver which drives the transistor gates of output drivers.

When $ENVG=H$, charge pump generates double the voltage of V_{DD} , which is supplied to V_G terminal through the inside.

When $ENVG=L$, charge pump is halted, and V_G terminal accepts the external power supply.

V_{REG} : Power supply for built-in regulator. Apply the required voltage with additional dropout voltage of regulator. By connecting V_{REGO} (regulator output) to V_{DDO1} , V_{DDO2} (Driver power supply), the power is provided to the drivers. Furthermore, the regulator output should be supplied to V_{DDO1} and V_{DDO2} by connecting de-coupling capacitor to get highly smoothed power supply.

(2) Regulator Output Voltage Control Terminal (V_{CONT})

V_{CONT} is the control terminal for regulator output voltage. As V_{REG} output voltage is variable from 0V by external DC voltage, driver output level can be used as sound volume.

(3) Regulator Enable Signal (EN_{REG})

The regulator is halted at "L" level, and works at "H" level.

(4) Charging pump Enable Signal (EN_{VG})

The charge pump is halted at "L" level, and works at "H" level.

(5) HP/LINE/BEEP Mode Control Terminal (EN_1 / EN_2)

Each mode can be selected by a combination setting of EN_1 and EN_2 .

The following table shows each output condition of each mode.

Mode	Input		Output		
	EN_1	EN_2	HP Amp.	LINE Amp.	BEEP Amp.
Standby Mode	L	L	HiZ	HiZ	HiZ
LINE Mode	L	H	HiZ	Active	HiZ
HP Mode	H	L	Active	HiZ	HiZ
BEEP Mode	H	H	HiZ	HiZ	Active

(6) BEEP Signal Input ($BEEP_{IN}$)

(7) BEEP Signal Output (O_{BEEP1} / O_{BEEP2})

BEEP signal is output in a square wave.

(8) Master Clock (MCK)

Master clock (MCK) synchronizes the audio signal inputs (D_{IN1} , D_{IN2}). The setup time and the hold time should be kept in the AC characteristics because D_{IN1} and D_{IN2} are latched on the rising edge of MCK. During the standby condition, MCK requires "L" level to avoid unnecessary power consumption. In addition, MCK requires jitter-free or fewer jitter because the jitter could lead to poor S/N ratio.

(9) Signal output (OUT_1 / OUT_2)

OUT_1 and OUT_2 terminals keep the Hi-z condition if output voltage of V_{REGO} is lower than detection voltage. Output signals are appeared as PWM signals through the use of V_{DDO1} and V_{DDO2} in the OUT_1 and OUT_2 terminals If the output voltage is over than detection voltage. Output signals will be converted to analog signals via 2nd-order or higher LC filter.

■ POWER ON/DOWN SEQUENCE

The pop-noise can be effectively suppressed with the following sequence when power ON and DOWN.

(1) Power ON / Power DOWN Sequence (EN_{VG}=H: Using internal V_G)

< Power On sequence >

- 1) Input the MCK after the start-up of V_{DD}. After of 100ms delay or more from MCK input, set EN_{VG} at "H" level.
- 2) Set EN_{SEG} at "H" level after 5ms delay or more.(at 0.1μF for the charge pump and 1μF for the smoothing capacitor)
- 3) After setting EN_{REG} at "H" level, input audio signals(D_{IN1}, D_{IN2}).
- 4) Set EN₁ at "H" level and EN₂ at "L" level after audio signal input. The audio signal input must be "Sound-less data" until V_{CONT} reaches a steady state.
- 5) V_{CONT} should be applied gradually to the target voltage. If the rising time of the application to the target V_{CONT} voltage is short, it may cause a pop-noise.

< Power Down sequence >

The sequence must be executed in inverse order of the power ON sequence.

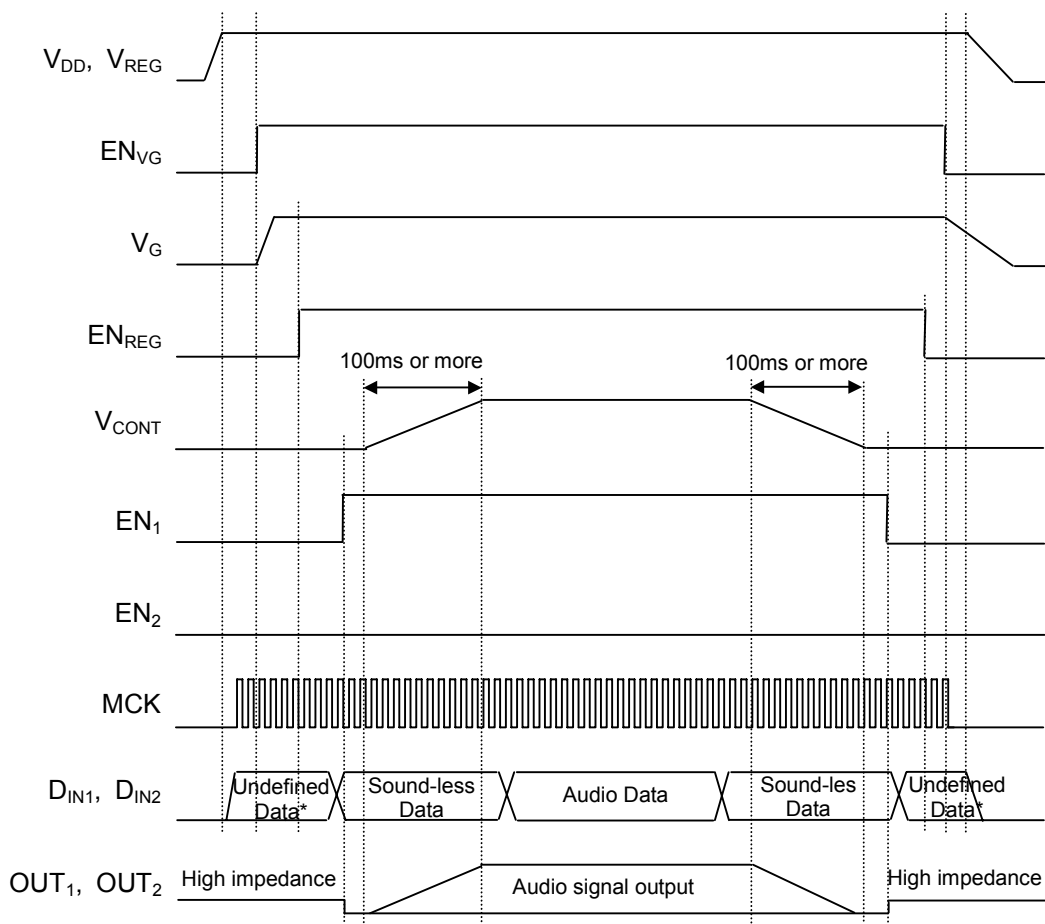

* : Do not set D_{IN1} and D_{IN2} at "H" level before the start-up of V_{DD}.

(2) Power ON / Power DOWN Sequence (EN_{VG}=L, V_G: Externally applied)

< Power ON sequence >

- 1) Input the MCK after the start-up of V_{DD}.
Apply V_G after the start-up V_{DD}. (As shown in the following sequence, V_G increases to V_{DD} through a internal protection diode after V_{DD} is turned on.)
- 2) Set EN_{REG} at "H" level after the start-up of V_G.
- 3) After setting EN_{REG} at "H" level, input audio signals (D_{IN1}, D_{IN2}).
- 4) Set EN₁ at "H" level and EN₂ at "L" level after audio signal input. The audio signal input must be "Sound-less data" until V_{CONT} reaches a steady state.
- 5) V_{CONT} should be applied gradually to the target voltage. If the rising time of the application to the target V_{CONT} voltage is short, it may cause a pop-noise.

< Power DOWN sequence >

The sequence must be executed in inverse order of the power ON sequence.

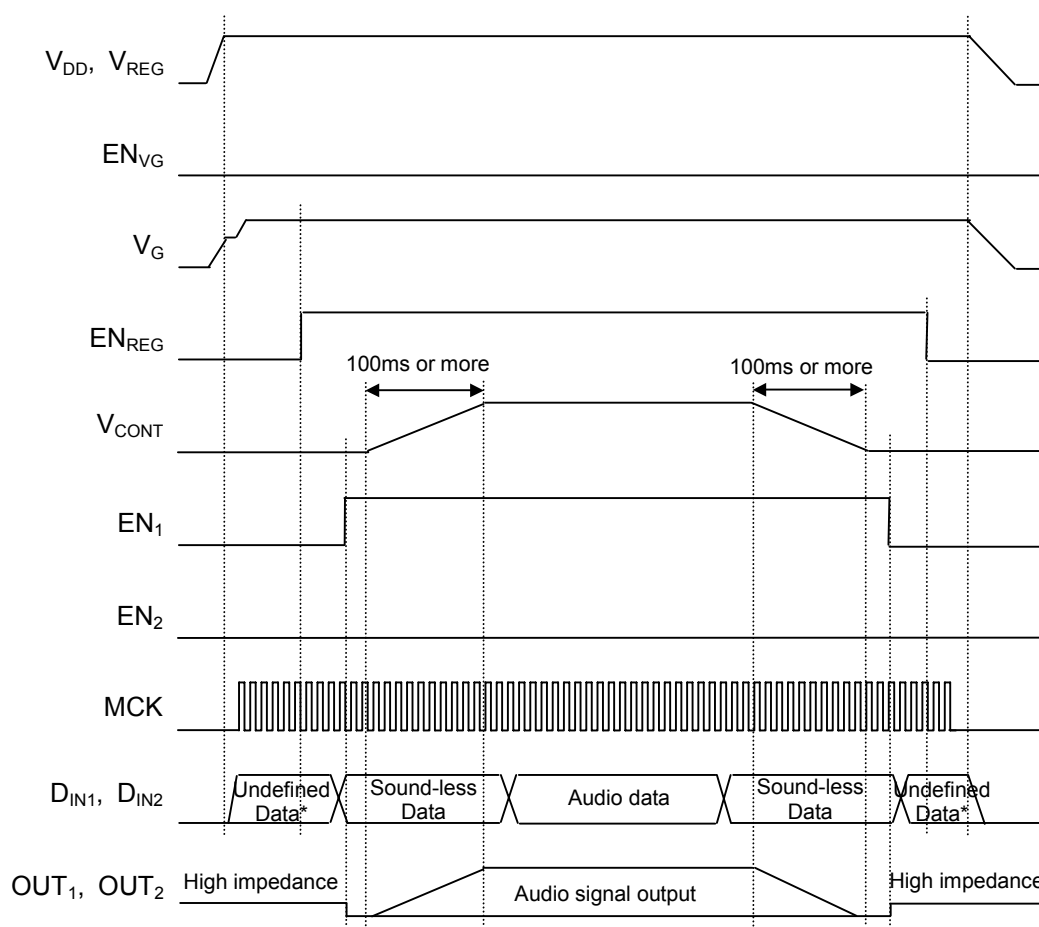

* : Do not set D_{IN1} and D_{IN2} at "H" level before the start-up of V_{DD}.

■ ABSOLUTE MAXIMUM RATINGS

(Ta=25°C)

PARAMETER	SYMBOL	RATING	UNIT
Supply Voltage	V_{DD}	-0.3 ~ +2.75	V
	V_{REG}	-0.3 ~ +5.5	V
	V_G	$V_{DD} \sim +6.0$	V
Input Voltage	V_{in}	-0.3 ~ $V_{DD}+0.3$	V
Operating Temperature	Ta	-20 ~ +85	°C
Storage Temperature	Tstg	-40 ~ +125	°C
Power Dissipation	P_D	640	mW

Note.3) The relations of $V_{DDO1}, V_{DDO2} < V_G$, $V_{REG} < V_G$ and $V_{DD} < V_G$ must be maintained during operations.

Note.4) All voltage values are specified as $V_{SS} = V_{SSO} = 0V$.

Note.5) If the LSI is used on condition beyond the absolute maximum rating, the LSI may be destroyed.

Using LSI within electrical characteristics is strongly recommended for normal operation. Use beyond the electrical characteristics conditions will cause malfunction and poor reliability.

Note.6) De-coupling capacitors for " $V_{DD}-V_{SS}$ ", " $V_{DDO1}-V_{SSO}$ " and " $V_{DDO2}-V_{SS}$ " should be connected for stable operation.

■ ELECTRICAL CHARACTERISTICS

(1) DC CHARACTERISTICS

(Ta=25°C, V_{DD}=2.0V, V_{DDO1}=V_{DDO2}=1.7V, V_{REG}=2.15V, V_{SS}=V_{SSO}=0.0V,
Load Impedance=16Ω, f_s=44.1kHz, unless otherwise noted)

PARAMETER	SYMBOL	CONDITIONS	MIN	TYP	MAX	UNIT
V _{DD} Supply Voltage	V _{DD}		1.9	2.0	2.6	V
V _G Supply Voltage	V _G	V _G : Externally applied	4.0	5.0	5.75	V
HP Driver High side Resistance	R _{HPH}	OUT _{1,2} =V _{DDO1,2} -0.1V	-	1.2	2	Ω
HP Driver Low side Resistance	R _{HPL}	OUT _{1,2} =0.1V	-	1.2	2	Ω
Line Driver High side Resistance	R _{LINEH}	OUT _{1,2} =V _{DDO1,2} -0.1V V _{DDO1,2} =2.75V	7.7	11	14.3	Ω
Line Driver Low side Resistance	R _{LINEL}	OUT _{1,2} =0.1V V _{DDO1,2} =2.75V	7.7	11	14.3	Ω
BEEP Output Voltage	V _{BEEPL}	MODE _B =L	-50 (2.45)	-48 (3.08)	-46 (3.88)	dBm (mVrms)
	V _{BEEPH}	MODE _B =H	-41 (6.91)	-39 (8.70)	-37 (10.95)	
Power Supply Current At Standby	I _{ST}	Standby Mode Stopping MCK, D _{IN1} , D _{IN2} , BEEP _{IN} EN _{REG} =L	-	-	1	μA
Power Supply Current At Operating (Mute signal input)	I _{DD1}	Using internal V _G HP Mode No-load operating, MCK=256fs D _{IN1} , D _{IN2} =16fs, EN _{REG} =H	-	0.95	1.6	mA
	I _{REG1}		-	0.70	1.2	
	I _{DD2}	V _G : Externally applied, HP Mode No-load operating, MCK=256fs, D _{IN1} , D _{IN2} =16fs, EN _{REG} =H V _G =5V	-	0.05	0.10	mA
	I _{REG2}		-	0.70	1.2	
	I _{G2}		-	0.75	1.2	
Digital Input Voltage	V _{IH}	MCK, D _{IN1} , D _{IN2} BEEP _{IN} , MODE _B EN ₁ , EN ₂ , EN _{REG} , EN _{VG}	0.7V _{DD}	-	V _{DD}	V
	V _{IL}		0	-	0.3V _{DD}	V
Input Leakage Current	I _{LK}	MCK, D _{IN1} , D _{IN2} BEEP _{IN} , MODE _B	-	-	±1	μA
Pull-down Resistance	R _{PD}	EN ₁ , EN ₂ , EN _{REG} , EN _{VG}	150	300	450	kΩ

(2) REGULATOR CHARACTERISTICS

($T_a=25^\circ\text{C}$, $V_{DD}=2.0\text{V}$, $V_{DDO1}=V_{DDO2}=1.7\text{V}$, $V_{REG}=2.15\text{V}$, $V_{SS}=V_{SSO}=0.0\text{V}$,
Load Impedance= 16Ω , $f_s=44.1\text{kHz}$, unless otherwise noted)

PARAMETER	SYMBOL	CONDITIONS	MIN	TYP	MAX	UNIT
Input Voltage	V_{REGH}	HP MODE	1.9	2.15	4.0	V
	V_{REGL}	LINE MODE	3.0	-	4.0	V
Output Voltage	V_{DDOH1}	HP MODE $V_{CONT}=1.5\text{V}$, $V_{REG}=2.5\text{V}$	1.9	2.0	2.1	V
	V_{DDOH2}	HP MODE $V_{CONT}=0.5\text{V}$, $V_{REG}=2.5\text{V}$	0.23	0.33	0.43	V
	V_{DDOL1}	LINE MODE $V_{CONT}=1.5\text{V}$, $V_{REG}=3.5\text{V}$	2.8	2.9	3.0	V
	V_{DDOL2}	LINE MODE $V_{CONT}=0.5\text{V}$, $V_{REG}=3.5\text{V}$	0.38	0.48	0.58	V
Output Current	I_{OUT}		70	-	-	mA
Sink Current	I_{SINK}		60	-	-	mA
Dropout Voltage	ΔV_{IO}	$I_{out}=70\text{mA}$ $V_{DDO1,2}=1.7\text{V}$	-	-	0.2	V
Ripple Rejection	RR	$V_r=0.1\text{Vrms}$, $I_{out}=70\text{mA}$ $f_r=1\text{kHz}$	36	44	-	dB
Load Regulation Voltage	V_{LR}	$I_{REGO}=0 \sim 24.3\text{mA}$	-	-	520	μVrms
Residual Voltage	V_{MIN}	$V_{CONT}=0.1\text{V}$	-	-	10	mV
V_{CONT}	V_{CONT}		0	-	V_{REG}	V

The following figure shows a representative example of V_{CONT} versus V_{REGO} .

At $V_{CONT}=1.5\text{V}$: $V_{REGO}=2.0\text{V}$ ($V_{REG}=2.5\text{V}$) in HP MODE, $V_{REGO}=2.9\text{V}$ ($V_{REG}=3.5\text{V}$) in LINE MODE.

At $V_{CONT}=0.5\text{V}$: $V_{REGO}=0.33\text{V}$ ($V_{REG}=2.5\text{V}$) in HP MODE, $V_{REGO}=0.48\text{V}$ ($V_{REG}=3.5\text{V}$) in LINE MODE.

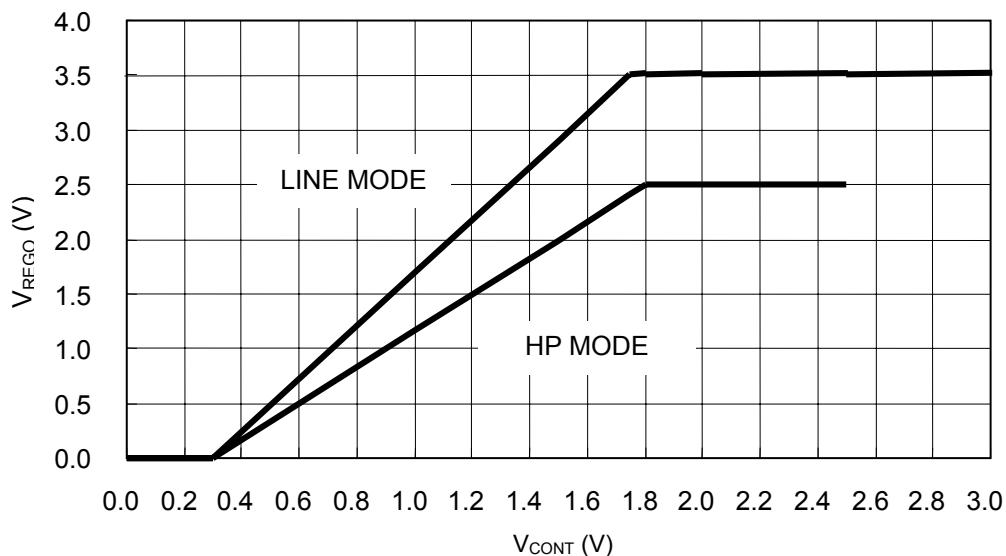

(3) AC CHARACTERISTICS

(Ta=25°C, V_{DD}=2.0V, V_{DDO1}=V_{DDO2}=1.7V, V_{REG}=2.15V, V_{SS}=V_{SSO}=0.0V,
Load Impedance=16Ω, f_s=44.1kHz, unless otherwise noted)

- Master Clock

PARAMETER	SYMBOL	CONDITIONS	MIN	TYP	MAX	UNIT
Frequency	f _{MCKI}		8	-	50	MHz
Pulse Width (H)	t _{MCKH}		8	-	-	ns
Pulse Width (L)	t _{MCKL}		8	-	-	ns

- Digital Audio Data

PARAMETER	SYMBOL	CONDITIONS	MIN	TYP	MAX	UNIT
D _{IN1} , D _{IN2} Setup Time	t _{DS}		5	-	-	ns
D _{IN1} , D _{IN2} Hold Time	t _{DH}		5	-	-	ns
EN ₁ , EN ₂ , EN _{REG} , EN _{VG} , BEEP _{IN} , MODE _B Rise Time, Fall Time	t _{Er} , t _{Ef}		-	-	50	ns

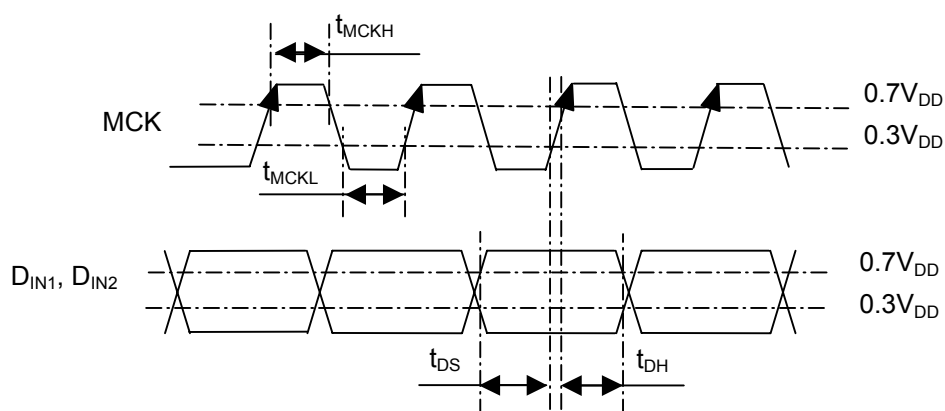

MCK, D_{IN1}, D_{IN2} Timing chart

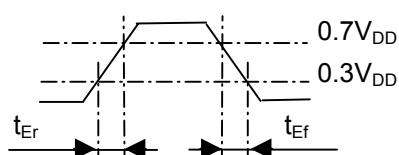

EN₁, EN₂, EN_{REG}, EN_{VG}, BEEP_{IN}, MODE_B Timing chart

NJU8715

APPLICATION CIRCUIT

(1) Using Internal V_G ($EN_{VG}=H$)

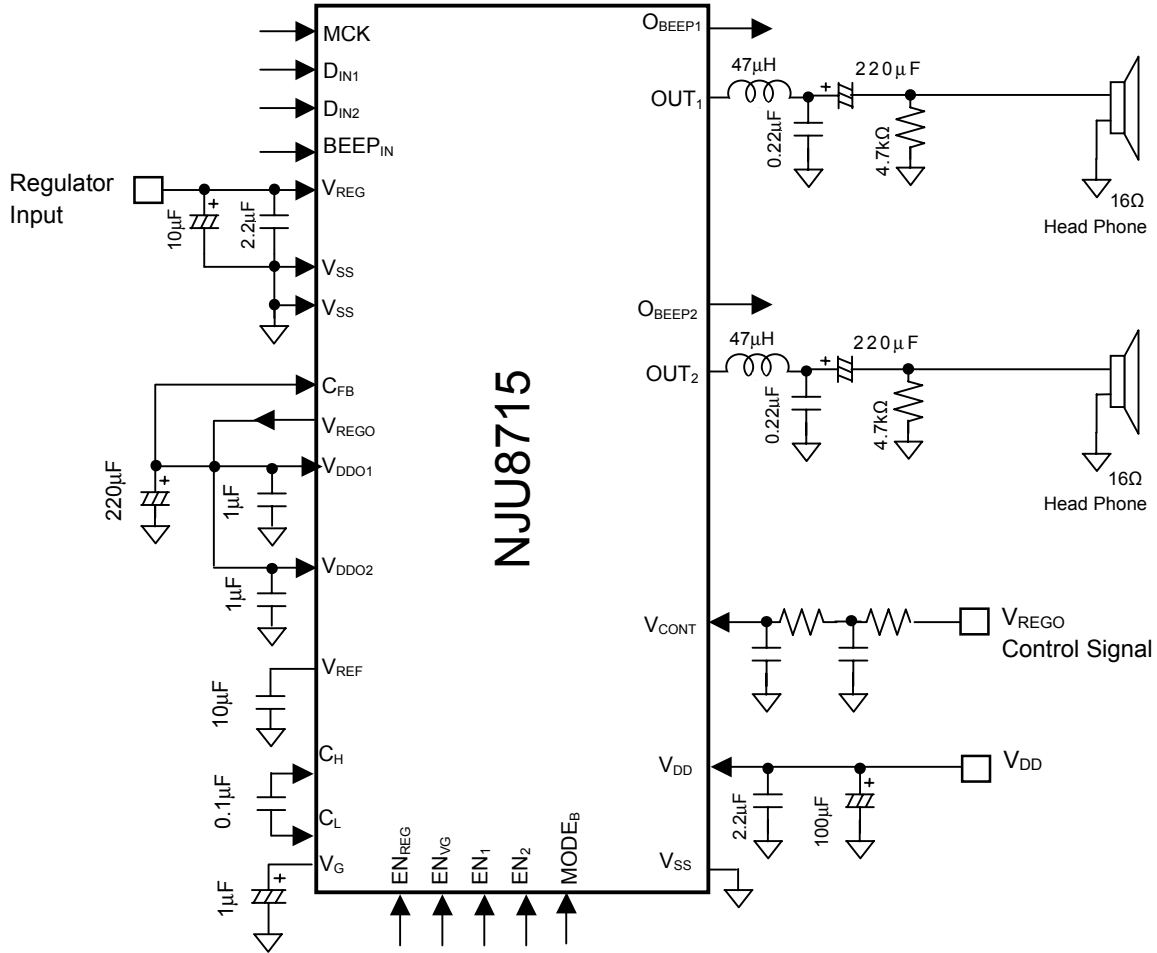

(2) V_G : Externally applied ($EN_{V_G}=L$)

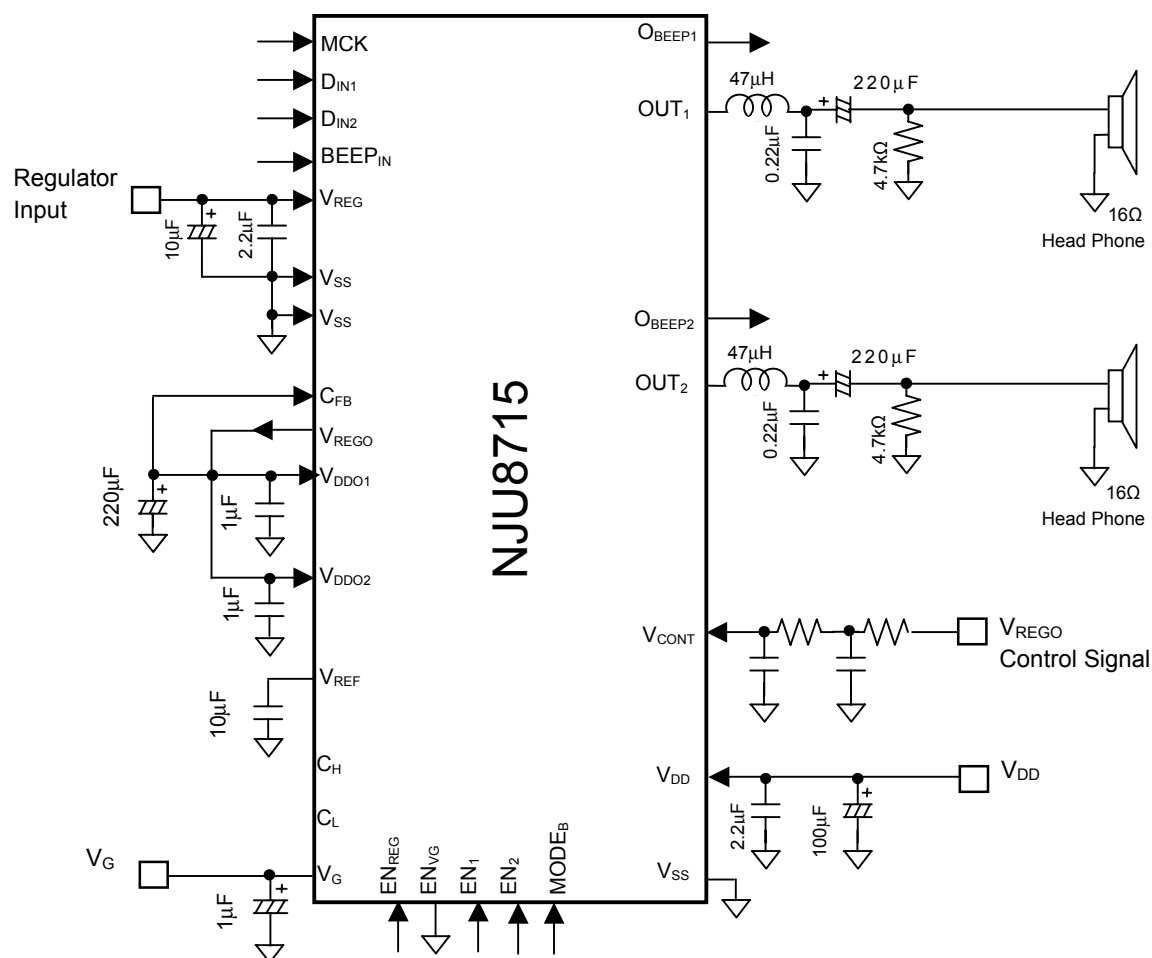

Note.7) C_H and C_L pins must be opened when V_G externally applied.

Note.8) De-coupling capacitors must be connected between each power supply pin and GND pin.

The capacitor value should be adjusted on the application circuit and the temperature. It may malfunction if capacity value is small.

Note.9) A large-capacitance for the de-coupling capacitors for headphone speaker is recommended to improve a low-frequency characteristics. In addition, a low-ESR(Equivalent series resistance) capacitor is recommended for high power efficiency.

Note.10) The above circuit shows only application example and does not guarantee the any electrical characteristics. Therefore, please consider and check the circuit carefully to fit your application.

[CAUTION]
The specifications on this databook are only given for information, without any guarantee as regards either mistakes or omissions. The application circuits in this databook are described only to show representative usages of the product and not intended for the guarantee or permission of any right including the industrial rights.

Mouser Electronics

Authorized Distributor

Click to View Pricing, Inventory, Delivery & Lifecycle Information:

[NJR:](#)

[NJU8715KN1](#)

Данный компонент на территории Российской Федерации

Вы можете приобрести в компании MosChip.

Для оперативного оформления запроса Вам необходимо перейти по данной ссылке:

<http://moschip.ru/get-element>

Вы можете разместить у нас заказ для любого Вашего проекта, будь то серийное производство или разработка единичного прибора.

В нашем ассортименте представлены ведущие мировые производители активных и пассивных электронных компонентов.

Нашей специализацией является поставка электронной компонентной базы двойного назначения, продукции таких производителей как XILINX, Intel (ex.ALTERA), Vicor, Microchip, Texas Instruments, Analog Devices, Mini-Circuits, Amphenol, Glenair.

Сотрудничество с глобальными дистрибьюторами электронных компонентов, предоставляет возможность заказывать и получать с международных складов практически любой перечень компонентов в оптимальные для Вас сроки.

На всех этапах разработки и производства наши партнеры могут получить квалифицированную поддержку опытных инженеров.

Система менеджмента качества компании отвечает требованиям в соответствии с ГОСТ Р ИСО 9001, ГОСТ РВ 0015-002 и ЭС РД 009

Офис по работе с юридическими лицами:

105318, г.Москва, ул.Щербаковская д.3, офис 1107, 1118, ДЦ «Щербаковский»

Телефон: +7 495 668-12-70 (многоканальный)

Факс: +7 495 668-12-70 (доб.304)

E-mail: info@moschip.ru

Skype отдела продаж:

moschip.ru

moschip.ru_4

moschip.ru_6

moschip.ru_9