



Robust, reliable
analog solutions

MC33772 and MC33664 Battery Cell Controller and Transformer Physical Layer

The MC33772 battery six-cell controller and MC33664 transformer physical layer solutions enable reliable, safe and bill of materials (BOM) optimized Li-ion cell control applications with low-cost, robust, high-speed isolated communication.

TARGET APPLICATIONS

Automotive Applications

- ▶ High-voltage battery management systems (200 V–+800 V)
- ▶ 14 V Li-ion battery management systems

Industrial Applications

- ▶ Energy storage systems (ESS)
- ▶ Uninterrupted power supply (UPS)
- ▶ E-bikes, e-scooters

This solution addresses all existing battery management system topologies that support centralized, distributed daisy chain as well as high-speed and robust daisy chain. It is compatible with 14 V Li-ion batteries with one analog front end (AFE) and optional high-speed isolated or SPI communications. These fully integrated battery monitoring devices are for automotive and industrial mission-critical applications.

High-speed and robust daisy chain is used as an alternative to CAN solutions. Fast data acquisition and communication to the pack controller can be achieved in only 0.86 ms for the pack controller to acquire conversions from six cells, seven external temperatures, the current and coulomb counter. The MC33772 controller can work down to three cells and up to six cells. Also, determination of individual cell impedances in one shot is synchronized for cell voltages and current measurements at 113 μ s.

With functional verification and diagnostics, the MC33772 and MC33664 support ISO 26262 SafeAssure® functional safety. Functional verification of cell measure, current measure, cell terminal openings or leakage and ADC precision checks are all performed.

FEATURES

- ▶ 5.0 V (7.0 V for TPL) $< V_{PWR} < 30$ V operation, 42 V transient for TPL communication
- ▶ Isolated 2 Mbps differential communication or 4 Mbps SPI
- ▶ Up to six cell voltage (differential) measurements and stack voltage measurements
- ▶ Synchronized cell voltage/current measurement with coulomb counting
- ▶ Seven ADC/GPIO/temperature sensor inputs
- ▶ Addressable on initialization
- ▶ Onboard 300 mA passive cell balancing low ohmic MOSFETS with diagnostics
- ▶ Designed to support ISO 26262, up to ASIL D safety capability
- ▶ Low-power modes
- ▶ 48-pin LQFP package



EXAMPLE: TYPICAL 14 V BATTERY MANAGEMENT SYSTEM CHIPSET FOR SPI COMMUNICATION

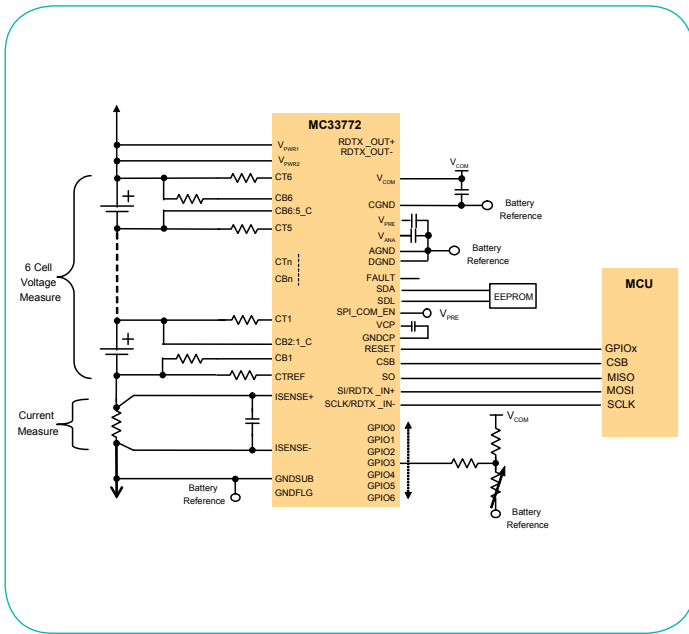

MC33772 AND MC33664 HIGH-VOLTAGE BATTERY MANAGEMENT SYSTEM FOR TPL COMMUNICATION

MC33772 AND MC33664 BLOCK DIAGRAM

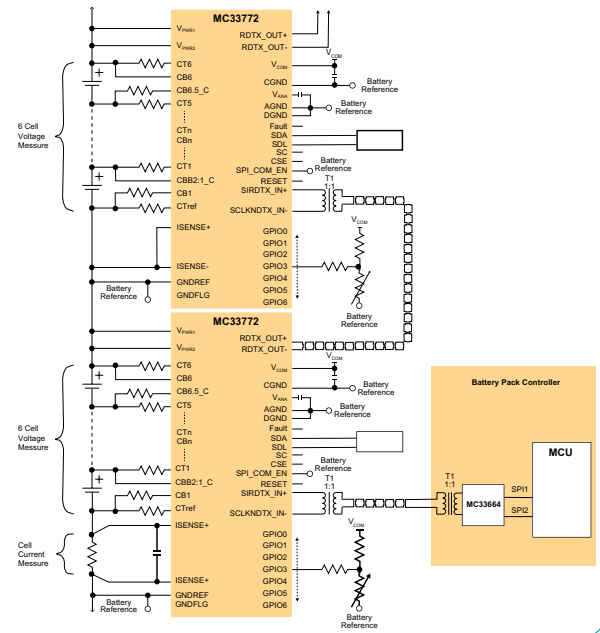

DEVELOPMENT TOOLS

Kit Number	Description
FRDM33772BSPIEVB (SPI mode)	MC33772 evaluation board
FRDM33772BTPLV (TPL mode)	MC33772 evaluation board
FRDM33664BEVB (TPL mode)	MC33664 evaluation board

MC33772 AND MC33664 PRODUCT DIFFERENTIATION

Features	Benefits
Integrated current channel and coulomb counting	Reduces BOM for 14 V Li-ion battery applications (only one AFE required)
Integrated current channel synchronized with cell voltage measurements	Determination of individual cell impedances in one shot for improved SoC/SoH prediction
Optional high-speed isolated or SPI communication	Addresses all existing battery management system topologies (centralized, distributed daisy chain, distributed CAN)
High-speed (2 Mbit/s) isolated high-speed differential communication	Allows BOM cost reduction by transition from CAN to daisy chain without compromise on communication speed
Fast data acquisition and communication to pack controller	Significant improvement of battery diagnostics
Hot plug and random cell connection robustness	No pre-damaging of cell and no damaging of devices during customer battery/electronics assembly
ESD/EMC robustness	ESD/EMC robustness avoids external components for robustness protection (BOM reduction, board space reduction)
Supports ISO 26262 SafeAssure® functional safety with single package solution	Has functional verification and diagnostics



PRODUCT LONGEVITY PROGRAM

These products are/ or may be supported by NXP®'s Product Longevity Program. For terms and conditions and to obtain a list of available products, visit www.nxp.com/ProductLongevity.

www.nxp.com/battery

NXP, the NXP logo and SafeAssure are trademarks of NXP B.V. All other product or service names are the property of their respective owners. © 2015–2018 NXP B.V.

Document Number: MC33772FSA4 REV 4



Данный компонент на территории Российской Федерации

Вы можете приобрести в компании MosChip.

Для оперативного оформления запроса Вам необходимо перейти по данной ссылке:

<http://moschip.ru/get-element>

Вы можете разместить у нас заказ для любого Вашего проекта, будь то серийное производство или разработка единичного прибора.

В нашем ассортименте представлены ведущие мировые производители активных и пассивных электронных компонентов.

Нашей специализацией является поставка электронной компонентной базы двойного назначения, продукции таких производителей как XILINX, Intel (ex.ALTERA), Vicor, Microchip, Texas Instruments, Analog Devices, Mini-Circuits, Amphenol, Glenair.

Сотрудничество с глобальными дистрибьюторами электронных компонентов, предоставляет возможность заказывать и получать с международных складов практически любой перечень компонентов в оптимальные для Вас сроки.

На всех этапах разработки и производства наши партнеры могут получить квалифицированную поддержку опытных инженеров.

Система менеджмента качества компании отвечает требованиям в соответствии с ГОСТ Р ИСО 9001, ГОСТ РВ 0015-002 и ЭС РД 009

Офис по работе с юридическими лицами:

105318, г.Москва, ул.Щербаковская д.3, офис 1107, 1118, ДЦ «Щербаковский»

Телефон: +7 495 668-12-70 (многоканальный)

Факс: +7 495 668-12-70 (доб.304)

E-mail: info@moschip.ru

Skype отдела продаж:

moschip.ru

moschip.ru_4

moschip.ru_6

moschip.ru_9