

# AFBR-1555ARZ, AFBR-2555ARZ (SMA Tx/Rx for SERCOS)

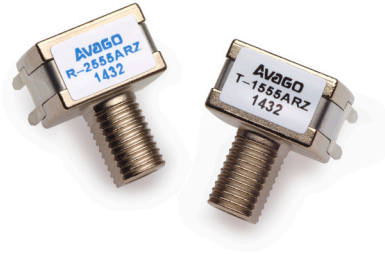

## Reinforced Metal Fiber Optic Transmitter and Receiver for SERCOS Applications

### Data Sheet



---

### Description

#### SERCOS

The Serial Realtime Communications System (SERCOS) is a standard digital interface for communication in industrial CNC applications. SERCOS is a European (EN 61491) and international standard (IEC 61491). The optical interface allows data rates of 2, 4, 8, and 16 MBd and data transfer between numerical controls and drives via fiber optic rings, with voltage isolation and noise immunity. The AFBR-1555ARZ and AFBR-2555ARZ products comply with SERCOS specifications for optical characteristics and connector style, and have guaranteed performance at 2, 4, 8, and 16 MBd data rates.

### Features

- Meets industrial SERCOS standard
- SMA ports
- 650-nm wavelength technology
- Reinforced metal housing and port
- Specified for use with 1-mm plastic optical fiber and 200- $\mu$ m plastic clad silica PCS
- Auto-insertable and wave solderable
- Supports SERCOS 2, 4, 8 and 16 MBd
- RoHS-compliant

### Applications

- Industrial control data links
- Factory automation data links
- Voltage isolation applications
- PLCs
- Motor drives
- Sensor, meter, and actuator interfaces

## Package and Handling Information

### Package Information

The AFBR-1555ARZ transmitter and AFBR-2555ARZ receiver are housed in a dual-in-line metal package, which is reinforced by a metal brace. This provides very high mechanical robustness. The package is designed for auto-insertion and wave soldering. Therefore, it is ideal for high volume production applications.

### Handling and Design Information

When soldering, it is advisable to leave the protective cap on the unit to keep the optics clean. Good system performance requires clean port optics and cable ferrules to avoid obstructing the optical path. Clean compressed air often is sufficient to remove particles of dirt. Methanol on a cotton swab also works well.

## Specified Link Performance

–40°C to +85°C, unless otherwise noted.

Parameter	Symbol	Min	Max	Unit	Conditions	Reference
Link Distance with AFBR-1555ARZ/2555ARZ	L	0.1	45	m	POF	Notes <sup>a, b, c, d</sup>
		0.1	100	m	PCS	Notes <sup>a, e, f, d</sup>
Pulse Width Distortion AFBR-1555ARZ/2555ARZ	PWD	–11	+11	ns	POF and PCS	Notes <sup>a, g</sup>

- With recommended Tx and Rx circuits (Figure 3 and Figure 5).
- POF HFBR-ExxyyyZ 0.23 dB/m worst-case attenuation.
- Including a 3-dB optical safety margin accounting for link service lifetime.
- Signaling rate up to 16 MBd.
- PCS worst-case attenuation is 10 dB/km (0°C to 70°C) and 12 dB/km (–40°C to 85°C).
- Including a 2-dB optical safety margin accounting for link service lifetime.
- For PWD calculation, the pulse width of the receiver output is compared versus the pulse width of the electrical input signal of the transmitter.  $PWD = PW_{RXout} - PW_{TXin}$ . Note that the AFBR-2555ARZ is an inverting receiver; thus an electrical high pulse at the transmitter input (LED on) causes an electrical low at the receiver output. For the characterization, the transmitter has been driven with an ideal (duty cycle = 50%) PRBS7 pattern input signal.

## Recommended Chemicals for Cleaning/ Degreasing AFBR-1555ARZ and AFBR-2555ARZ Products

Alcohols: methyl, isopropyl, isobutyl.

Aliphatics: hexane, heptane.

Other: soap solution, naphtha.

Do not use partially halogenated hydrocarbons such as 1,1,1 trichloroethane, ketones such as MEK, acetone, chloroform, ethyl acetate, methylene dichloride, phenol, methylene chloride or N-methylpyrrolidone. Also, Avago does not recommend the use of cleaners that use halogenated hydrocarbons because of their potential environmental harm.

## AFBR-1555ARZ Transmitter

The AFBR-1555ARZ transmitter incorporates a 650-nm LED within a reinforced metal housing. The high light output power enables the use of both plastic optical fiber (POF) and Plastic Clad Silica (PCS). The AFBR-1555ARZ can be operated up to 16 MBd using a simple driver circuit. The AFBR-1555ARZ is compatible with SMA connectors.

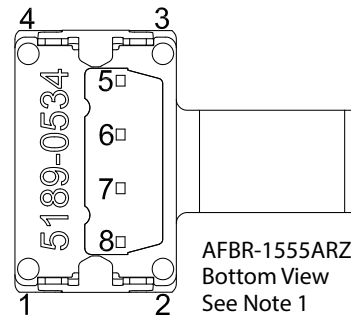

Pin	Function	Pin	Function
1	Shield	5	n.c.
2	Shield	6	n.c.
3	Shield	7	Cathode
4	Shield	8	Anode

**Note 1:**

The 4 mounting and retaining pins (Shield) are electrically connected to the metal housing. It is required that these pins are electrically connected to ground to maintain metal housing shield effectiveness. These pins should be connected to chassis GND, if available, to reach best performance.

## Absolute Maximum Ratings

Parameter	Symbol	Min	Max	Unit
Storage and Operating Temperature	$T_{S,O}$	-40	+85	°C
Transmitter Peak Forward Input Current <sup>a</sup>	$I_{F,PK}$	—	45	mA
Transmitter Short-term Peaking Forward Input Current <sup>b</sup>	$I_{F,PKshort}$	—	80	mA
Transmitter Average Forward Input Current	$I_{F,AVG}$	—	30	mA
Transmitter Reverse Input Voltage	$V_R$	—	3	V
Lead Soldering Cycle - Temp <sup>c</sup>	$T_{SOLD}$	—	260	°C
Lead Soldering Cycle - Time <sup>c</sup>	$t_{SOLD}$	—	10	s

- a. For  $I_{F,PK} > 30$  mA, the duty factor must maintain  $I_{F,AVG} \leq 30$  mA and pulse width  $\leq 1$   $\mu$ s.
- b. Maximum short-term peaking forward current must not longer be applied than 5 ns to improve rise time and/or enhance signaling rate. Applying a short-term peaking forward current must not result in exceeding 30-mA average forward current.
- c. 1.6 mm below seating plane.

## Peak Output Power

–40°C to +85° unless otherwise stated.

Parameter	Symbol	Min	Typ <sup>a</sup>	Max	Unit	Conditions	Reference
30-mA, 1-mm POF 200-μm PCS	$P_{T,30}$	–6.5 –18	–1 –12	2 –9	dBm	$I_{F,DC} = 30 \text{ mA}$	Notes <sup>b, c</sup> <a href="#">Figure 2</a>
10-mA, 1-mm POF	$P_{T,10}$	–11.5	–6	–3	dBm	$I_{F,DC} = 10 \text{ mA}$	Notes <sup>b, c</sup> <a href="#">Figure 2</a>
5-mA, 1-mm POF	$P_{T,5}$	–14.5	–9	–6	dBm	$I_{F,DC} = 5 \text{ mA}$	Notes <sup>b, c</sup> <a href="#">Figure 2</a>
3-mA, 1-mm POF	$P_{T,3}$	–16.5	–11	–8	dBm	$I_{F,DC} = 3 \text{ mA}$	Notes <sup>b, c</sup> <a href="#">Figure 2</a>
30-mA, 1-mm POF, 25°C	$P_{T,30,25}$	–3	–1	1	dBm	$I_{F,DC} = 30 \text{ mA}$ $T = 25^\circ\text{C}$	Notes <sup>b, d</sup> <a href="#">Figure 2</a>
Optical Power Temperature Coefficient	$\Delta P_T / \Delta T$	—	–0.01	—	dB/°C	–40°C to +25°C	
		—	–0.02	—	dB/°C	+25°C to +85°C	

- Typical data are at 25°C.
- Optical power measured with polished connector end face at the end of 1 meter of 1-mm diameter POF with a numerical aperture (NA) of 0.5, or of 200-μm diameter PCS, with NA = 0.37, using a large area detector.
- Minimum and maximum values for PT over temperature are based on a fixed drive current.
- This parameter refers to initial (0hrs) operation at 25°C only. Any degradation by aging effects of the LED as well as temperature effects are not considered.

## Electrical and Optical Characteristics

–40°C to +85° unless otherwise stated.

Parameter	Symbol	Min	Typ <sup>a</sup>	Max	Unit	Conditions	Reference
Forward Voltage	$V_F$	1.4	—	2.3	V	$I_{F,DC} = 3 \text{ mA to } 30 \text{ mA}$	<a href="#">Figure 1</a>
Forward Voltage Temperature Coefficient	$\Delta V_F / \Delta T$	—	1.6	—	mV/°C	$I_{F,DC} = 30 \text{ mA}$	<a href="#">Figure 1</a>
Reverse Input Breakdown Voltage	$V_{BR}$	9	20	—	V	—	
Peak Emission Wavelength	$\lambda_{PK}$	630	650	685	nm	—	
Peak Emission Wavelength Temperature Coefficient	$\Delta \lambda / \Delta T$	—	0.16	—	nm/K	—	
Spectral Width	FWHM	—	20	—	nm	—	
Diode Capacitance	$C_O$	—	30	70	pF	—	
Optical Rise Time	$t_R$	—	—	16	ns	10% to 90%	Note <sup>b</sup>
Optical Fall Time	$t_F$	—	—	16	ns	90% to 10%	Note <sup>b</sup>

- Typical data are at 25°C.
- Using the recommended drive circuitry according to [Figure 3](#).

## AFBR-1555ARZ Characteristics with POF

Figure 1 Typical Forward Voltage vs. Drive Current

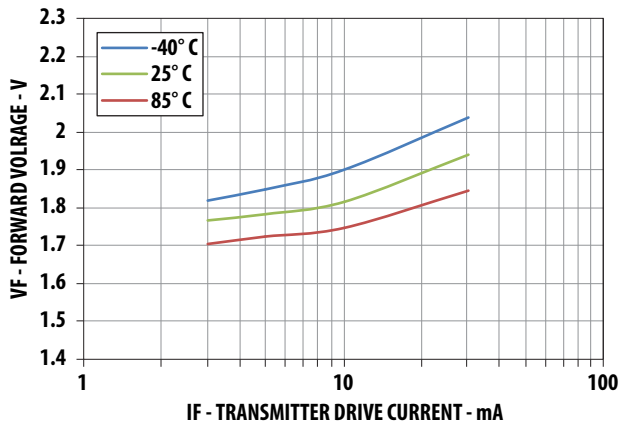
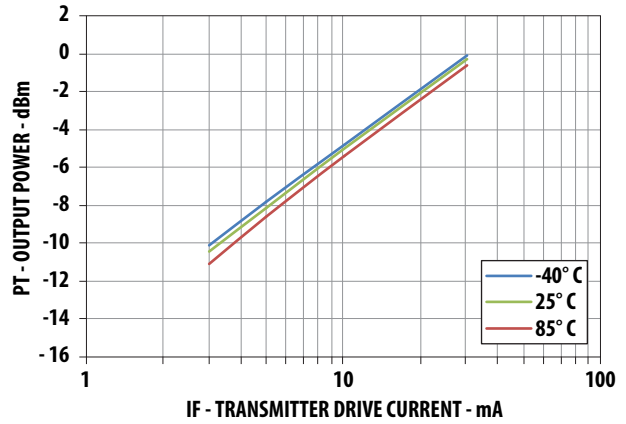
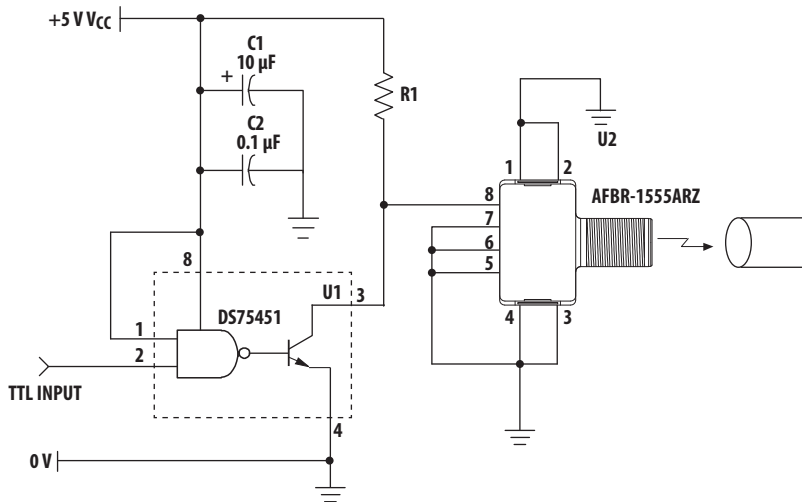

Figure 2 Typical Optical Power vs. Drive Current



## Recommended Circuitry for AFBR-1555ARZ

Figure 3 Recommended Transmitter Drive Circuitry



Note:

R1 must be determined for the required IF value.

For example:

R1 = 100Ω, for  $I_F \sim 30$  mA

R1 = 330Ω, for  $I_F \sim 10$  mA

(for  $V_{CC} = 5$  V)

## AFBR-2555ARZ Receiver

The AFBR-2555ARZ receiver consists of an IC with an integrated photodiode to produce a logic compatible output, assembled into a reinforced metal housing. The receiver output is a *push-pull* stage compatible with TTL and CMOS logic. The AFBR-2555ARZ fits together with SMA connectors.

Pin	Function	Pin	Function
1	Shield	5	n.c.
2	Shield	6	VCC.
3	Shield	7	GND
4	Shield	8	VO

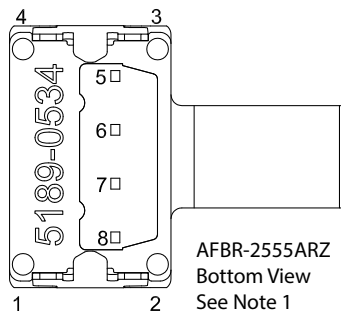

### Note 1:

The 4 mounting and retaining pins (Shield) are electrically connected to the metal housing. It is required that these pins are electrically connected to ground to maintain metal housing shield effectiveness. They should be connected to chassis GND, if available, to reach best performance.

## Absolute Maximum Ratings

Parameter	Symbol	Min	Max	Unit
Storage and Operating Temperature	$T_{S,O}$	-40	+85	$^{\circ}\text{C}$
Supply Voltage	$V_{CC}$	-0.3	5.5	V
Maximum DC Output Current	$I_{O,DC}$	—	10	mA
Lead Soldering Cycle, Temp <sup>a</sup>	$T_{SOLD}$	—	260	$^{\circ}\text{C}$
Lead Soldering Cycle, Time <sup>a</sup>	$t_{SOLD}$	—	10	s

a. 1.6 mm below seating plane.

## Electrical/Optical Characteristics

-40  $^{\circ}\text{C}$  to +85  $^{\circ}\text{C}$ ,  $V_{CC} = 3.3\text{V} \pm 5\%$  or  $5\text{V} \pm 5\%$ , unless otherwise stated.

Parameter	Symbol	Min	Typ <sup>a</sup>	Max	Unit	Conditions	Reference
Optical Input Peak Power Range	$P_{INPK}$	-20 -22	—	-1 -3	dBm	1-mm POF 200- $\mu\text{m}$ PCS $ P_{WD}  < 11$ ns	Notes <sup>b, c</sup> <a href="#">Figure 4</a>
Data Rate	DR	2	—	16	MBd	—	Note <sup>c</sup>
Supply Voltage	$V_{CC}$	3.135	3.3	3.465	V	—	
		4.75	5	5.25	V	—	
Supply Current	$I_{CC}$	—	11	20	mA	$V_O = \text{open}$	
High Level Output Voltage	$V_{OH}$	2.4	$V_{CC} - 0.3$	$V_{CC}$	V	$R_L = 2$ k $\Omega$	
Low Level Output Voltage	$V_{OL}$	—	0.2	0.4	V	$R_L = 2$ k $\Omega$	
Output Rise Time (10% to 90%)	$t_R$	—	—	5	ns	$C_L = 10$ pF	Note <sup>b</sup>
Output Fall Time (90% to 10%)	$t_F$	—	—	5	ns	$C_L = 10$ pF	Note <sup>b</sup>

a. Typical data are at 25 $^{\circ}\text{C}$ ,  $V_{CC} = 5.0$  V.

b. In recommended receiver circuit, with an optical signal from the recommended transmitter circuit. The specified  $|P_{WD}|$  is valid for the receiver only, assuming an ideal 50% duty cycle optical input signal.

c. Verified with a PRBS2<sup>7</sup>-1 signal with mark ratio = 1/2.  $P_{INPK} = P_{INAVG} + 3$  dB.

**Figure 4 Typical POF Receiver Pulse Width Distortion vs. Optical Power**

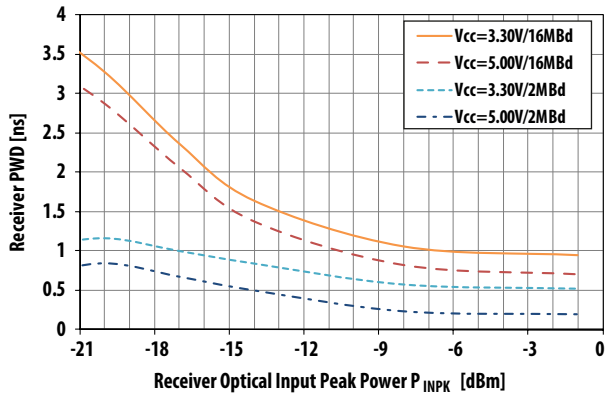

Note:

$$PWD = PW_{OPT\_OUT\_AVG} - PW_{EL\_IN\_AVG}$$

The receiver has inverting characteristics; thus, a positive light pulse (light on) causes a logic low at the data output.

## Recommended Circuitry for AFBR-2555ARZ

**Figure 5 Recommended Receiver Circuitry**

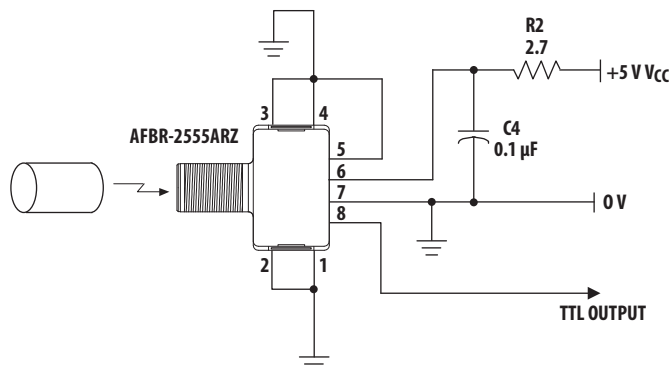

## Mechanical Dimensions

### AFBR-1555ARZ/AFBR-2555ARZ

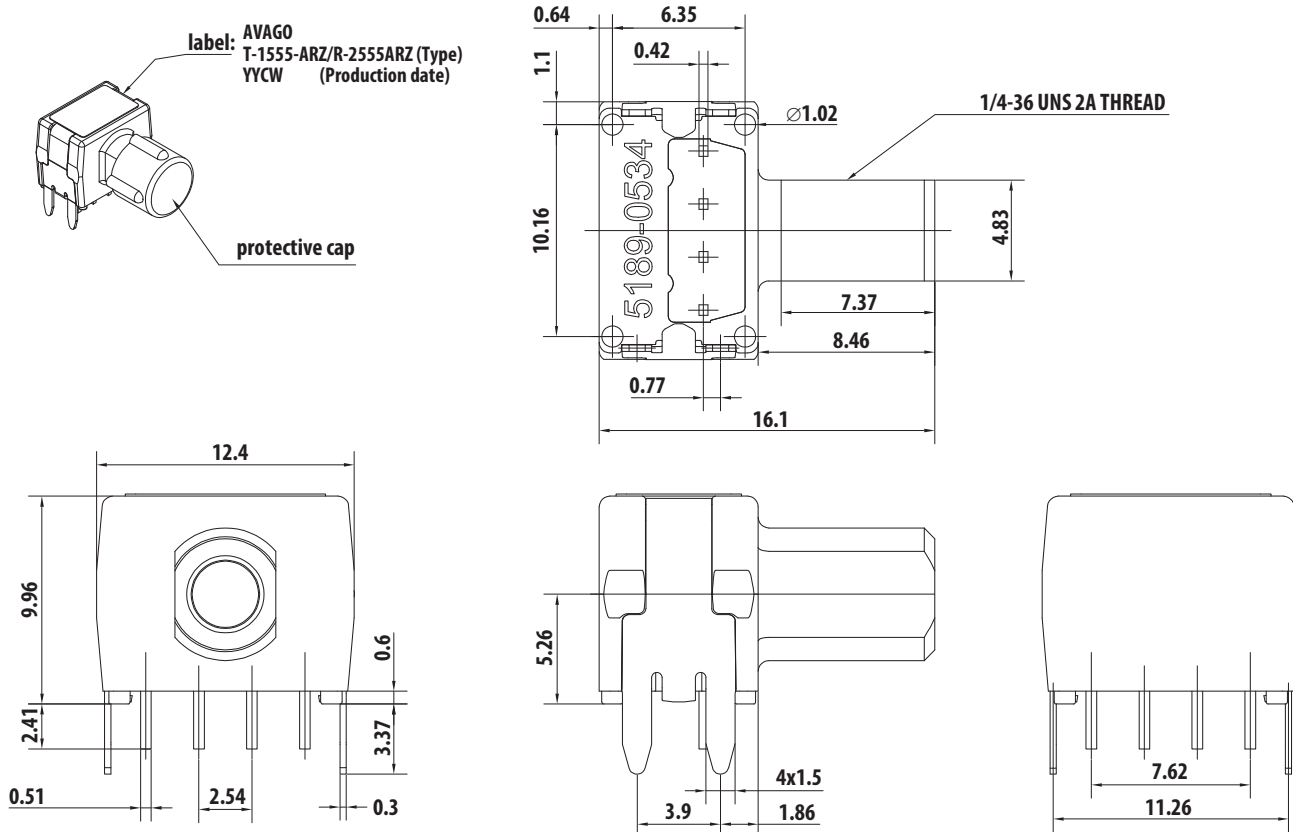

Dimensions are in mm

### Protective Cap

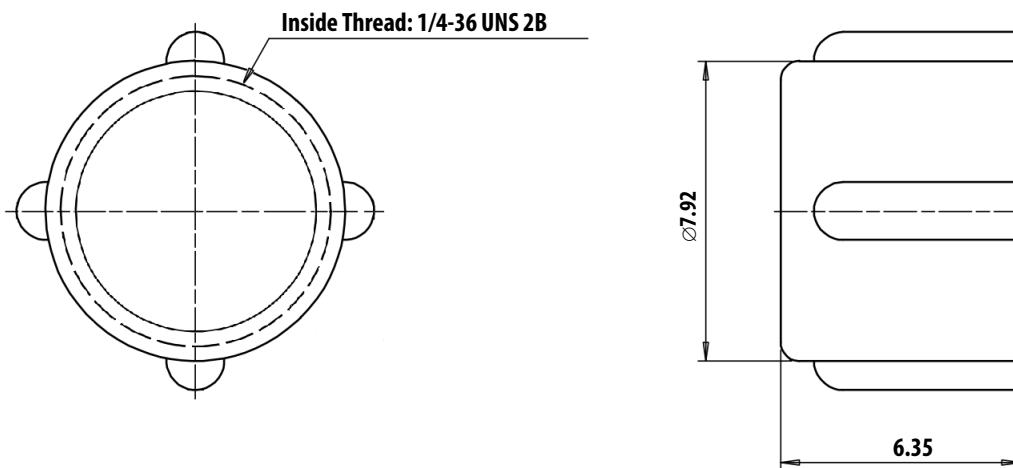

Dimensions are in mm



---

For product information and a complete list of distributors, please go to our web site:  
[www.broadcom.com](http://www.broadcom.com).

Broadcom, the pulse logo, Connecting everything, Avago Technologies, Avago, and the A logo are among the trademarks of Broadcom and/or its affiliates in the United States, certain other countries and/or the EU.

Copyright © 2016 by Broadcom. All Rights Reserved.

The term "Broadcom" refers to Broadcom Limited and/or its subsidiaries. For more information, please visit [www.broadcom.com](http://www.broadcom.com).

Broadcom reserves the right to make changes without further notice to any products or data herein to improve reliability, function, or design.

Information furnished by Broadcom is believed to be accurate and reliable. However, Broadcom does not assume any liability arising out of the application or use of this information, nor the application or use of any product or circuit described herein, neither does it convey any license under its patent rights nor the rights of others.

AV02-4406EN – October 3, 2016



## Данный компонент на территории Российской Федерации

### Вы можете приобрести в компании MosChip.

Для оперативного оформления запроса Вам необходимо перейти по данной ссылке:

<http://moschip.ru/get-element>

Вы можете разместить у нас заказ для любого Вашего проекта, будь то серийное производство или разработка единичного прибора.

В нашем ассортименте представлены ведущие мировые производители активных и пассивных электронных компонентов.

Нашей специализацией является поставка электронной компонентной базы двойного назначения, продукции таких производителей как XILINX, Intel (ex.ALTERA), Vicor, Microchip, Texas Instruments, Analog Devices, Mini-Circuits, Amphenol, Glenair.

Сотрудничество с глобальными дистрибьюторами электронных компонентов, предоставляет возможность заказывать и получать с международных складов практически любой перечень компонентов в оптимальные для Вас сроки.

На всех этапах разработки и производства наши партнеры могут получить квалифицированную поддержку опытных инженеров.

Система менеджмента качества компании отвечает требованиям в соответствии с ГОСТ Р ИСО 9001, ГОСТ РВ 0015-002 и ЭС РД 009

### Офис по работе с юридическими лицами:

105318, г.Москва, ул.Щербаковская д.3, офис 1107, 1118, ДЦ «Щербаковский»

Телефон: +7 495 668-12-70 (многоканальный)

Факс: +7 495 668-12-70 (доб.304)

E-mail: [info@moschip.ru](mailto:info@moschip.ru)

Skype отдела продаж:

moschip.ru

moschip.ru\_4

moschip.ru\_6

moschip.ru\_9