

1800/1805 Series

TO-8, 0 psi to 3 psi, 0 psi to 150 psi Silicon Pressure Sensors



DESCRIPTION

The 1800/1805 Series sensors are high performance TO-8 pressure transducers specifically designed to address a variety of both low and medium pressure original equipment manufacture applications.

The transducers offer two performance grades and a variety of compensation options, including span and calibration to within ± 2 mV (normalized output). The 1800/1805 Series can operate with either constant current or voltage excitation.

FEATURES

- Standard pressure ranges from 0 psi to 3 psi, 0 psi to 150 psi
- Gauge, absolute or differential models
- Voltage or constant current excitation
- Choice of temperature compensation options
 - Laser trim, normalized output
 - Laser trim, standard output
 - Resistor compensation
- Uncompensated version available for microprocessor-based designs

The 1800/1805 Series contains a solid state piezoresistive pressure sensor mounted in a standard TO-8 package. They are printed circuit board and pin-for-pin compatible with other TO-8 pressure sensors.

POTENTIAL APPLICATIONS

- Instrumentation calibration
- Avionics/aerospace
- Medical equipment
- HVAC
- Pneumatic controls

1800/1805 Series

TO-8, 0 psi to 3 psi, 0 psi to 150 psi

ENVIRONMENTAL SPECIFICATIONS (All devices)

Characteristic	Parameter	Characteristic	Parameter
Supply voltage, V_s	10 Vdc	Insulation resistance	100 MOhm at 50 Vdc
Compensated temperature range	-1 °C to 54 °C [34 °F to 129 °F]	Humidity	50 % \pm 10 %
Operating temperature range	-40 °C to 121 °C [-40 °F to 257 °F]	Common-mode pressure	150 psig
Vibration	10 g rms at 20 Hz to 200 Hz	Max. soldering temperature	260 °C [500 °F] 10 s max.
Shock	100 g for 11 ms	Excitation voltage V_s	Supply voltage $V_s = 15$ Vdc max.
Life	100 million cycles	Excitation current	Supply current $I_s = 2$ mA max.

PERFORMANCE CHARACTERISTICS⁽¹⁾

Characteristic	Min.	Typ.	Max.	Unit
Zero pressure offset ⁽¹⁾	–	–	± 0.5	mV
Zero pressure offset (3 psi to 5 psi only) ⁽¹⁾	–	–	± 1	mV
Full-scale span ⁽²⁾				
Standard output–current excitation	75	–	150	mV
Standard output–voltage excitation	40	–	120	mV
Normalized output–current excitation	98	–	102	mV
Normalized output–current excitation (3 psi only)	73	–	77	mV
Normalized output–voltage excitation	38	–	42	mV
Pressure non-linearity ⁽³⁾	–	± 0.15	± 0.20	%FSS
Pressure hysteresis ⁽³⁾	–	–	± 0.0125	%FSS
Repeatability	–	–	± 0.0125	%FSS
Temperature effect on offset ⁽⁴⁾	–	–	± 0.5	mV
Temperature effect on offset (3 psi and 5 psi only) ⁽⁴⁾	–	–	± 1	mV
Temperature effect on span	–	–	± 0.5	mV
Temperature effect on span (3 psi and 5 psi only) ⁽⁴⁾	–	–	± 1	mV
Thermal hysteresis	–	± 0.1	–	%FSS
Response time ⁽⁵⁾	–	–	1	ms
Long term stability of offset and span ⁽⁶⁾	–	–	± 0.2	%FSS
Common mode voltage ⁽⁷⁾				
Standard output–current excitation	–	50 %	–	input
Standard output–voltage excitation	–	50 %	–	input
Normalized output–current excitation	–	35 %	–	input
Normalized output–voltage excitation	–	25 %	–	input
Input resistance	–	–	–	–
Current excitation	2.0	–	8.0	k Ω
Voltage excitation	8.0	–	40	k Ω
Output resistance	3.5	–	6.0	k Ω

PRESSURE RANGE SPECIFICATIONS

Catalog Listing	Pressure Range	Top Side Overpressure ⁽⁸⁾	Bottom Side Overpressure ⁽⁹⁾
1805-00 (G,D) - (K,L) (0..4) (M,L,N)	0 psi to 3 psi	15 psi	9 psi
1805-01 (G,D) - (K,L) (0..4) (M,L,N)	0 psi to 5 psi	25 psi	15 psi
1800-02 (G,D) - (K,L) (0..4) (M,L,N)	0 psi to 10 psi	50 psi	30 psi
1800-03 (G,D) - (K,L) (0..4) (M,L,N)	0 psi to 15 psi	65 psi	45 psi
1800-07 (G,D) - (K,L) (0..4) (M,L,N)	0 psi to 30 psi	250 psi	50 psi
1800-08 (G,D) - (K,L) (0..4) (M,L,N)	0 psi to 50 psi	350 psi	50 psi
1800-09 (G,D) - (K,L) (0..4) (M,L,N)	0 psi to 100 psi	350 psi	50 psi
1800-10 (G,D) - (K,L) (0..4) (M,L,N)	0 psi to 150 psi	350 psi	50 psi

Notes:

- Reference conditions (unless otherwise noted); $T_A = 25$ °C [77 °F], Supply $V_s = 10$ Vdc ± 0.01 Vdc or $I_s = 1.5$ mA ± 0.0015 mA.
- Full-scale span (FSS) is the algebraic difference between the output voltage at full-scale pressure and the output at zero pressure. FFS is ratiometric to the supply voltage.
- Pressure non-linearity is based on best-fit straight line from the zero to the full-scale pressure. Pressure hysteresis is the maximum output difference at any point within the operating pressure range for increasing and decreasing pressure.
- Maximum error band of the offset voltage or span over the compensated temperature range, relative to the 25 °C [77 °F] reading.
- Response time for a 0 psi to full-scale span pressure step change, 10 % to 90 % rise time.
- Long term stability over a six month period.
- Common mode voltage as measured from output to ground. For higher levels of common mode voltage, contact the factory.
- Pressure overrange: Top: 5 x full-scale pressure or ≤ 350 psi, whichever is less.
- Pressure overrange: Bottom: 3 x full-scale or ≤ 50 psi, whichever is less.

Silicon Pressure Sensors

STANDARD COMPENSATION AND TRIM CHOICES

For maximum convenience, the 1800/1805 Series is temperature compensated from -1 °C to 54 °C [34 °F to 129 °F]. Other temperature ranges are available upon request.

Normalized Output Option: For design convenience and sensor interchangeability, the 1800/1805 Series is available with normalized output (100 ±2 mV dc in current excited versions with pressure range >3 psi). Normalized output for current excited 3 psi devices is 75 ±2 mV dc.

Laser Trim: Compensation is accomplished by using an in-house laser trim facility that allows for tighter product performance control and improved flexibility in response to special customer performance requirements.

Resistors: This option includes a printout of suggested temperature compensation and zero offset resistor values for each individual sensor.

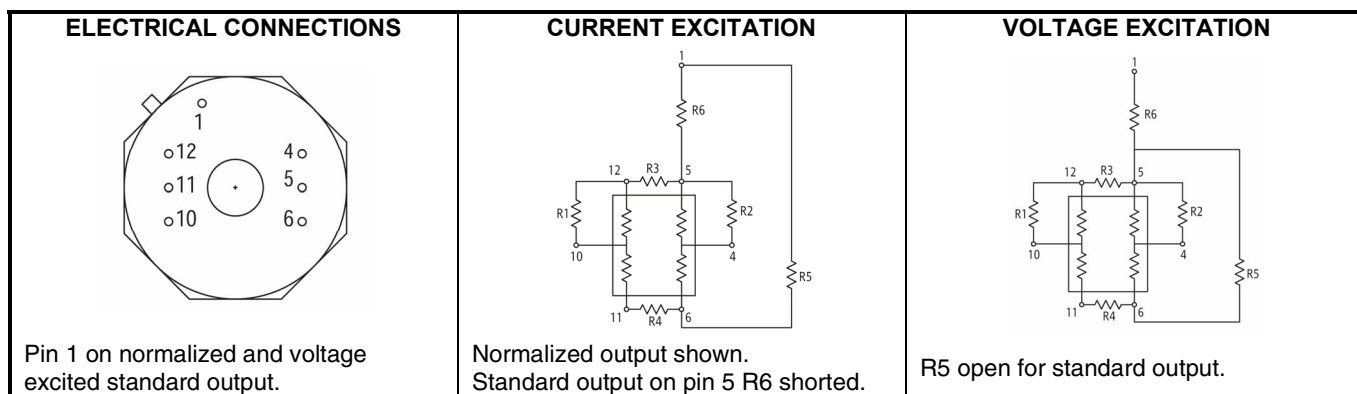

EXTERNAL CONNECTIONS

POSITIVE PRESSURE ON TOP AND BOTTOM SIDES								Current or Voltage Excitation – Normalized Output	
Current Excitation – Standard Output				Voltage Excitation – Standard Output				Laser Trim Board	
Discrete Resistor	Laser Trim Board			Discrete Resistor	Laser Trim Board			Laser Trim Board	
Pin	Connection	Pin	Connection	Pin	Connection	Pin	Connection	Pin	Connection
4	+ Output	4	+ Output	4	+ Output	4	+ Output	4	+ Output
5	+ Input	5	+ Input	5	+ Input	5	NC	5	NC
6	- Input	6	- Input	6	- Input	6	- Input	6	- Input
10	- Output	10	- Output	10	- Output	10	- Output	10	+ Output
11	NC	11	NC	11	NC	11	NC	11	NC
12	NC	12	NC	12	NC	12	NC	12	NC
						1	+ Input	1	+ Input

PRESSURE CONNECTION OPTIONS

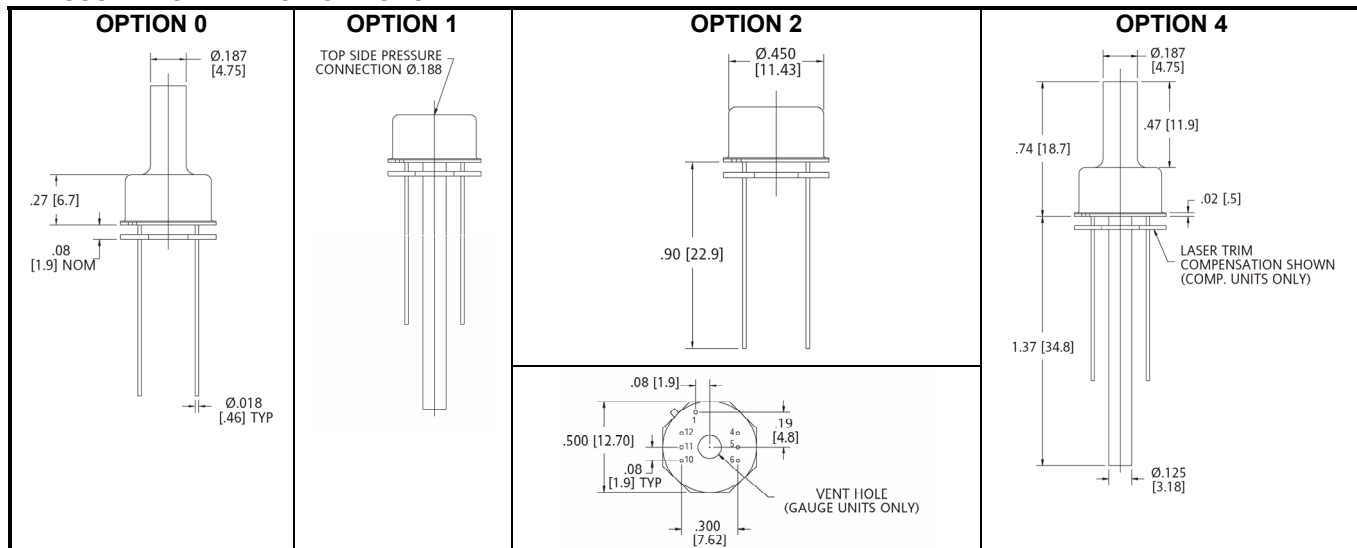

ORDER GUIDE

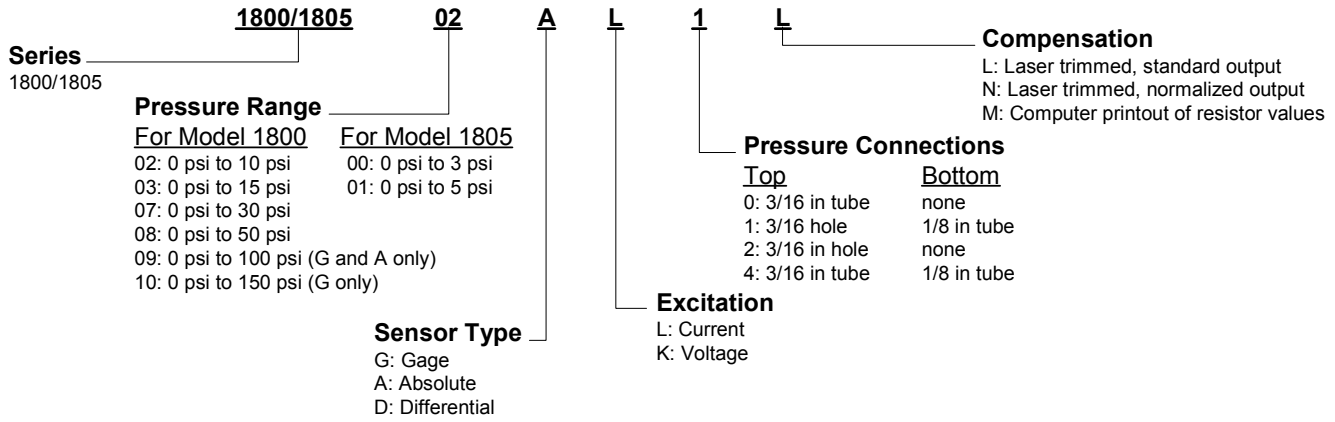

Note:

Transducer recommended for use with non-corrosive, non-condensing gases.

⚠ WARNING
PERSONAL INJURY
 DO NOT USE these products as safety or emergency stop devices or in any other application where failure of the product could result in personal injury.
Failure to comply with these instructions could result in death or serious injury.

WARRANTY/REMEDY

Honeywell warrants goods of its manufacture as being free of defective materials and faulty workmanship. Honeywell's standard product warranty applies unless agreed to otherwise by Honeywell in writing; please refer to your order acknowledgement or consult your local sales office for specific warranty details. If warranted goods are returned to Honeywell during the period of coverage, Honeywell will repair or replace, at its option, without charge those items it finds defective. **The foregoing is buyer's sole remedy and is in lieu of all other warranties, expressed or implied, including those of merchantability and fitness for a particular purpose. In no event shall Honeywell be liable for consequential, special, or indirect damages.**

While we provide application assistance personally, through our literature and the Honeywell web site, it is up to the customer to determine the suitability of the product in the application. Specifications may change without notice. The information we supply is believed to be accurate and reliable as of this printing. However, we assume no responsibility for its use.

⚠ WARNING
MISUSE OF DOCUMENTATION

- The information presented in this product sheet is for reference only. Do not use this document as a product installation guide.
- Complete installation, operation, and maintenance information is provided in the instructions supplied with each product.

Failure to comply with these instructions could result in death or serious injury.

SALES AND SERVICE

Honeywell serves its customers through a worldwide network of sales offices, representatives and distributors. For application assistance, current specifications, pricing or name of the nearest Authorized Distributor, contact your local sales office or:

- E-mail: info.sc@honeywell.com
- Internet: www.honeywell.com/sensing
- Phone and Fax:
 - Asia Pacific +65 6355-2828
+65 6445-3033 Fax
 - Europe +44 (0) 1698 481481
+44 (0) 1698 481676 Fax
 - Latin America +1-305-805-8188
+1-305-883-8257 Fax
 - USA/Canada +1-800-537-6945
+1-815-235-6847
+1-815-235-6545 Fax

Automation and Control Solutions

Sensing and Control
 Honeywell
 11 West Spring Street
 Freeport, Illinois 61032
www.honeywell.com/sensing

008137-2-EN IL50 GLO Printed in USA
 October 2005
 © 2005 Honeywell International Inc.



Данный компонент на территории Российской Федерации

Вы можете приобрести в компании MosChip.

Для оперативного оформления запроса Вам необходимо перейти по данной ссылке:

<http://moschip.ru/get-element>

Вы можете разместить у нас заказ для любого Вашего проекта, будь то серийное производство или разработка единичного прибора.

В нашем ассортименте представлены ведущие мировые производители активных и пассивных электронных компонентов.

Нашей специализацией является поставка электронной компонентной базы двойного назначения, продукции таких производителей как XILINX, Intel (ex.ALTERA), Vicor, Microchip, Texas Instruments, Analog Devices, Mini-Circuits, Amphenol, Glenair.

Сотрудничество с глобальными дистрибьюторами электронных компонентов, предоставляет возможность заказывать и получать с международных складов практически любой перечень компонентов в оптимальные для Вас сроки.

На всех этапах разработки и производства наши партнеры могут получить квалифицированную поддержку опытных инженеров.

Система менеджмента качества компании отвечает требованиям в соответствии с ГОСТ Р ИСО 9001, ГОСТ РВ 0015-002 и ЭС РД 009

Офис по работе с юридическими лицами:

105318, г.Москва, ул.Щербаковская д.3, офис 1107, 1118, ДЦ «Щербаковский»

Телефон: +7 495 668-12-70 (многоканальный)

Факс: +7 495 668-12-70 (доб.304)

E-mail: info@moschip.ru

Skype отдела продаж:

moschip.ru

moschip.ru_4

moschip.ru_6

moschip.ru_9