

# NCN49597

## Power Line Carrier Modem

The NCN49597 is a powerful power line communication SoC combining low power Cortex M0 processor with a high precision analogue front end. Based on a dual 4800 Baud S-FSK channel technology, it offers an ideal compromise between speed and robustness for operations in a harsh environment.

Pin to pin and function compatible with its predecessor, the AMIS49587, this new generation extends frequency up to Cenelec D band for use in applications such as e-metering, home automation and street lighting.

Executing by default the IEC61334-5-1 PHY and MAC stack, the NCN49597 benefits for more than 10 years of field experience in eMetering and delivers innovative features such as a smart synchronisation and automatic baud rate detection.

Fully reprogrammable, it also supports building automation standard or full custom protocol. The configurable GPIOs allow connecting peripherals such as LCD or metering ICs.

### Features

- Power Line Carrier Modem for 50 and 60 Hz Mains
- Embedded ARM Cortex M0 Processor, Programmable Embedded Software
- Compliant with IEC 61334-5-1 and CENELEC EN 50065-1
- Dual S-FSK Channel, Each at 4800 Baud
- Programmable Carrier Frequencies in CENELEC A-D Band
- Half Duplex
- Data Rate Selectable:
  - 300 – 600 – 1200 – 2400 – 4800 baud (@ 50 Hz)
  - 360 – 720 – 1440 – 2880 – 5760 baud (@ 60 Hz)
- Repetition and Smart Synchronization Algorithm Boost the Robustness of Communication
- Selectable UART/Full Duplex UART to Application Microcontroller
- SCI Port to Application Microcontroller
- SCI Baudrate Selectable: 9.6 – 19.2 – 38.4 – 115.2 kb
- Power Supply 3.3 V
- Junction Temperature Range: -40°C to +125°C
- These Devices are Pb-Free and are RoHS Compliant

### Typical Applications

- AMR: Automated Remote Meter Reading
- Building Automation
- Solar Power
- Streetlight Control
- Transmission of Alerts (Fire, Gas Leak, Water Leak)



ON Semiconductor®

<http://onsemi.com>

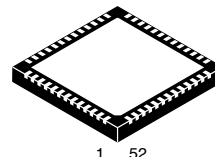

QFN52 8x8, 0.5P  
CASE 485M

### MARKING DIAGRAMS

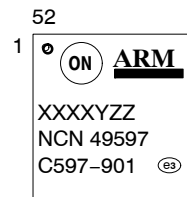

XXXX = Date Code  
Y = Plant Identifier  
ZZ = Traceability Code

### ORDERING INFORMATION

See detailed ordering and shipping information in the package dimensions section on page 32 of this data sheet.

Application Example

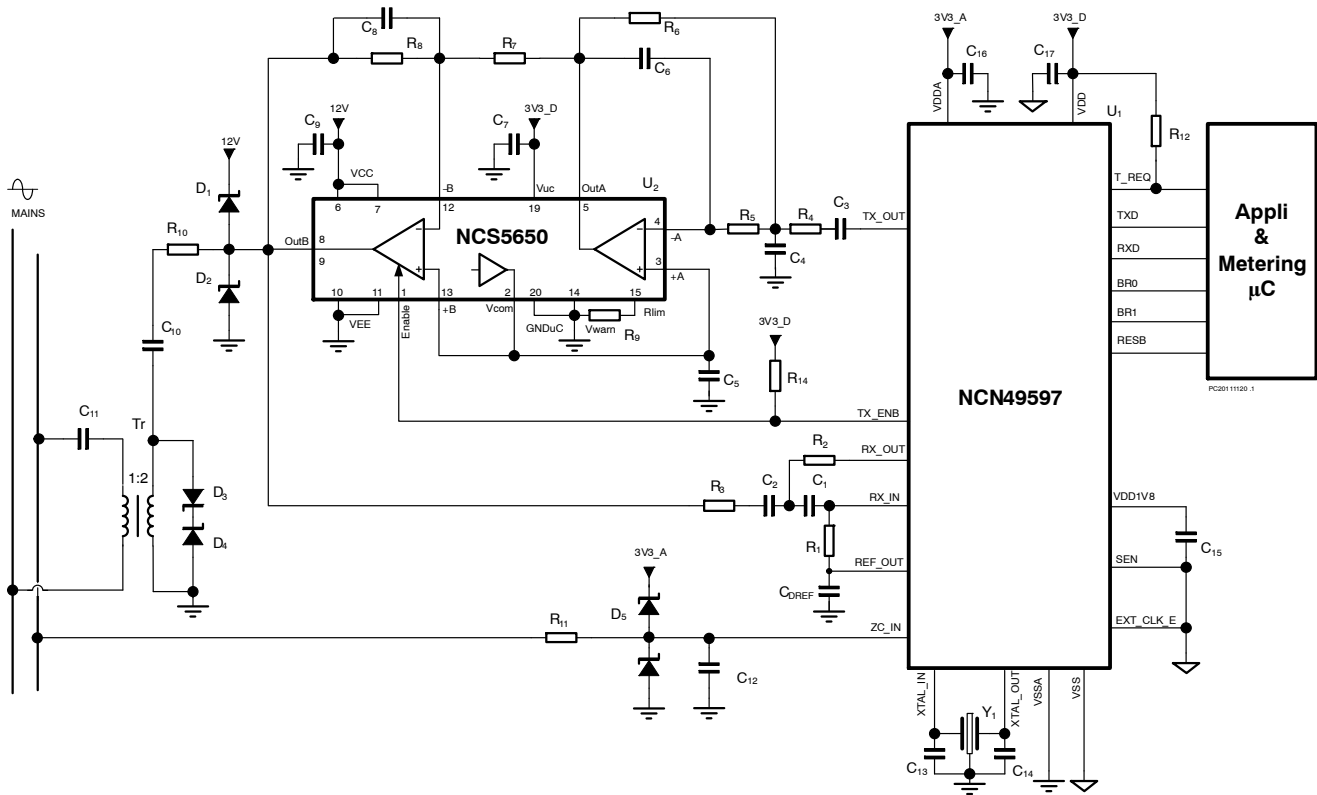

Figure 1. Typical Application for the NCN49597S-FSK Modem

Figure 1 shows an S-FSK PLC modem build around NCN49597. For synchronization the line frequency is coupled in via a 1 MΩ resistor. The Schottky diode pair D<sub>5</sub> clamps the voltage within the input range of the zero cross detector. In the receive path a 2<sup>nd</sup> order high pass filter blocks the mains frequency. The corner point defined by C<sub>1</sub>, C<sub>2</sub>, R<sub>1</sub> and R<sub>2</sub> is designed at 10 kHz. In the transmit path a 3<sup>th</sup> order low pass filter build around the NCS5650 power operational amplifier suppresses the 2<sup>nd</sup> and 3<sup>rd</sup> harmonics to be in line with the CENELEC EN 50065-1 specification.

The filter components are tuned for a space and mark frequency of 63.3 and 74 kHz respectively. The output of the amplifier is coupled via a DC blocking capacitor C<sub>10</sub> to a 2:1 pulse transformer Tr. The secondary of this transformer is coupled to the mains via a high voltage capacitor C<sub>11</sub>. High energetic transients from the mains are clamped by the protection diode combination D<sub>3</sub>, D<sub>4</sub> together with D<sub>1</sub>, D<sub>2</sub>. Because the mains is not galvanic isolated care needs to be taken when interfacing to a microcontroller or a PC!

Table 1. EXTERNAL COMPONENTS LIST AND DESCRIPTION

Component	Function – Remark	Typ Value	Tolerance	Unit
C <sub>1</sub> , C <sub>2</sub>	High pass receive filter	1.5	±10%	nF
C <sub>5</sub> , C <sub>DREF</sub>	V <sub>REF_OUT</sub> ; V <sub>REF_OUT</sub> decoupling cap – ceramic	1	-20 +80%	μF
C <sub>7</sub> , C <sub>9</sub> , C <sub>16</sub> , C <sub>17</sub>	Decoupling block capacitor	100	-20 +80%	nF
C <sub>3</sub>	TX_OUT coupling capacitor	470	±20%	nF
C <sub>4</sub>	Low pass transmit filter	470	±10%	pF
C <sub>6</sub>	Low pass transmit filter	68	±10%	pF
C <sub>8</sub>	Low pass transmit filter	3	±10%	pF
C <sub>10</sub>	TX coupling cap; 1 A rms ripple @ 70 kHz	10	±20%	μF

**Table 1. EXTERNAL COMPONENTS LIST AND DESCRIPTION**

Component	Function – Remark	Typ Value	Tolerance	Unit
C <sub>11</sub>	High Voltage coupling capacitor; 630 V	220	±20%	nF
C <sub>12</sub>	Zero Cross noise suppression	100	±20%	pF
C <sub>13</sub> , C <sub>14</sub>	X-tal load capacitor	36	±20%	pF
C <sub>15</sub>	Decoupling block capacitor 1.8 V internal supply	1	-20 +80%	µF
R <sub>1</sub>	High pass receive filter	22	±1%	kΩ
R <sub>2</sub>	High pass receive filter	11	±1%	kΩ
R <sub>3</sub> , R <sub>9</sub> , R <sub>12</sub> , R <sub>13</sub>	High pass receive filter; Alarm current ; Pull up	10	±1%	kΩ
R <sub>4</sub>	Low pass transmit filter	3,3	±1%	kΩ
R <sub>5</sub>	Low pass transmit filter	10	±1%	kΩ
R <sub>6</sub>	Low pass transmit filter	8,2	±1%	kΩ
R <sub>7</sub>	Low pass transmit filter	500	±1%	Ω
R <sub>8</sub>	Low pass transmit filter	3	±1%	kΩ
R <sub>10</sub>	TX Coupling resistor ; 0.5 W	0,47	±1%	Ω
R <sub>11</sub>	Zero Cross coupling HiV	1	±5%	MΩ
D <sub>1</sub> , D <sub>2</sub>	High current Schottky Clamp diodes	MBRA430		
D <sub>3</sub> , D <sub>4</sub>	TVS diodes	P6SMB6.8AT3G		
D <sub>5</sub>	Double low current Schottky clamp diode	BAS70-04		
Y1	X-tal	48 MHz		
Tr	2:1 Signal transformer			
U1	PLC modem	NCN49597		
U2	Power Operational Amplifier	NCS5650		

**Table 2. ABSOLUTE MAXIMUM RATINGS**

Rating	Symbol	Min	Max	Unit
<b>ABSOLUTE MAXIMUM RATINGS SUPPLY</b>				
<b>Power Supply Pins VDD, VDDA, VSS, VSSA</b>				
Absolute max. digital power supply	V <sub>DD_ABSM</sub>	V <sub>SS</sub> - 0.3	3.9	V
Absolute max. analog power supply	V <sub>DDA_ABSM</sub>	V <sub>VSSA</sub> - 0.3	3.9	V
Absolute max. difference between digital and analog power supply	V <sub>DD</sub> - V <sub>DDA_ABSM</sub>	-0.3	0.3	V
Absolute max. difference between digital and analog ground	V <sub>SS</sub> - V <sub>VSSA_ABSM</sub>	-0.3	0.3	V
<b>ABSOLUTE MAXIMUM RATINGS NON 5V SAFE PINS</b>				
<b>Non 5V Safe Pins: TX_OUT, ALC_IN, RX_IN, RX_OUT, REF_OUT, ZC_IN, XIN, XOUT, TDO, TDI, TCK, TMS, TRSTB, TEST</b>				
Absolute maximum input for normal digital inputs and analog inputs	V <sub>IN_ABSM</sub>	V <sub>SS</sub> - 0.3	V <sub>DD</sub> + 0.3	V
Absolute maximum voltage at any output pin	V <sub>OUT_ABSM</sub>	V <sub>SS</sub> - 0.3	V <sub>DD</sub> + 0.3	V
<b>ABSOLUTE MAXIMUM RATINGS 5V SAFE PINS</b>				
<b>5V Safe Pins: TX_ENB, TXD, RXD, BR0, BR1, IO3 .. IO11, RESB</b>				
Absolute maximum input for digital 5V safe inputs	V <sub>5VS_ABSM</sub>	V <sub>SS</sub> - 0.3	6.0	V
Absolute maximum voltage at 5V safe output pin	V <sub>OUT5V_ABSM</sub>	V <sub>SS</sub> - 0.3	3.9	V

Stresses exceeding Maximum Ratings may damage the device. Maximum Ratings are stress ratings only. Functional operation above the Recommended Operating Conditions is not implied. Extended exposure to stresses above the Recommended Operating Conditions may affect device reliability.

# NCN49597

## Normal Operating Conditions

Operating ranges define the limits for functional operation and parametric characteristics of the device as described in the Normal Operating Conditions section and for the reliability specifications as listed in Detailed Hardware Description section. Functionality outside these limits is not implied.

Total cumulative dwell time outside the normal power supply voltage range or the ambient temperature under bias, must be less than 0.1% of the useful life as defined in Detailed Hardware Description section.

**Table 3. OPERATING RANGES**

Rating	Symbol	Min	Max	Unit
Power Supply Voltage Range	V <sub>DD</sub>	3.0	3.6	V
Junction Temperature Range	T <sub>J</sub>	-40	125	°C
Ambient Temperature Range	T <sub>A</sub>	-40	115	°C

## PIN DESCRIPTION

### QFN Packaging

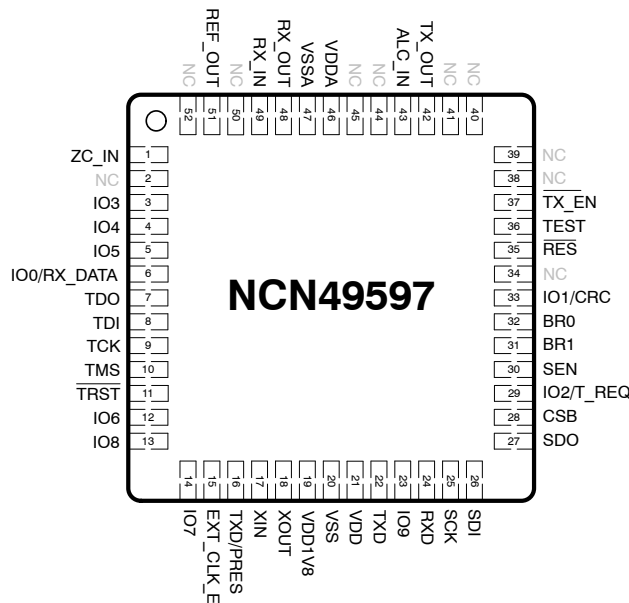

**Figure 2. QFN Pin-out of NCN49597 (Top view)**

**Table 4. NCN49597QFN PIN FUNCTION DESCRIPTION**

Pin No.	Pin Name	I/O	Type	Description
1	ZC_IN	In	A	50/60 Hz input for mains zero cross detection
3..5, 12..14, 23	IO3 .. IO9	In/Out	D, 5V Safe	General Purpose I/O's
6	IO0/RX_DATA	Out	D, 5V Safe, OD	Data reception indication (in ROM mode)
7	TDO	Out	D, 5V Safe	Test data output
8	TDI	In	D, 5V Safe, PD	Test data input
9	TCK	In	D, 5V Safe, PD	Test clock

# NCN49597

**Table 4. NCN49597QFN PIN FUNCTION DESCRIPTION**

Pin No.	Pin Name	I/O	Type	Description
10	TMS	In	D, 5V Safe, PD	Test mode select
11	TRSTB	In	D, 5V Safe, PD	Test reset bar (active low)
15	EXT_CLK_E	in	D, 5V Safe	External Clock Enable input
16	TXD/PRES	Out	D, 5V Safe	Output of transmitted data (TXD) or PRE_SLOT signal (PRES)
17	XIN	In	A	Xtal input (can be driven by an internal clock)
18	XOUT	Out	A	Xtal output (output floating when XIN driven by external clock)
19	VDD1V8		P	1V8 regulator output. Foresee a decoupling capacitor
20	VSS		P	Digital ground
21	VDD		P	3.3V digital supply
22	TXD	Out	D, 5V Safe, OD	SCI transmit output
24	RXD	In	D, 5V Safe	SCI receive input (Schmitt trigger input)
25	SCK	Out	D, 5V Safe	SPI interface external Flash
26	SDI	In	D, 5V Safe	SPI interface external Flash (Schmitt trigger input)
27	SDO	Out	D, 5V Safe	SPI interface external Flash
28	CSB	In	D, 5V Safe	SPI interface external Flash (Schmitt trigger input)
29	IO2/T_REQ	In	D, 5V Safe	Transmit Request input (in ROM mode)
30	SEN	In	D, 5V Safe, PD	SPI interface Enable external Flash
31	BR1	In	D, 5V Safe	SCI baud rate selection
32	BR0	In	D, 5V Safe	SCI baud rate selection
33	IO1/CRC	Out	D, 5V Safe, OD	Correct frame CRC indication (in ROM mode)
35	RESB	In	D, 5V Safe	Master reset bar (Schmitt trigger input, active low)
36	TEST	In	D, 5V Safe, PD	Hardware Test enable (Schmitt trigger input)
37	TX_ENB	Out	D, 5V Safe, OD	TX enable (active low)
42	TX_OUT	Out	A	Transmitter output
43	ALC_IN	In	A	Automatic level control input
46	VDDA		P	3.3V analog supply
47	VSSA		P	Analog ground
48	RX_OUT	Out	A	Output of receiver low noise operational amplifier
49	RX_IN	In	A	Positive input of receiver low noise operational amplifier
51	REF_OUT	Out	A	Reference output for stabilization
2, 34, 38..41, 44, 45, 50, 52	NC			Pins 2, 34, 38..41, 44, 45, 50, 52 are not connected. These pins need to be left open or connected to the GND plane.

P: Power pin	5V Safe: IO that support the presence of 5V on bus line
A: Analog pin	Out: Output signal
D: Digital pin	In: Input signal
PD: Internal Pull Down resistor	ROM mode: IO0, IO1 and IO2 has predefined function when NCN49597 boots from ROM
OD: Open Drain Output	

**Detailed Pin Description**

**VDDA**

VDDA is the positive analog supply pin. Nominal voltage is 3.3 V. A ceramic decoupling capacitor  $C_{DA} = 100 \text{ nF}$  must be placed between this pin and the VSSA. Connection path of this capacitance to the VSSA on the PCB should be kept as short as possible in order to minimize the serial resistance.

**REF\_OUT**

REF\_OUT is the analog output pin which provides the voltage reference used by the A/D converter. This pin must be decoupled to the analog ground by a  $1 \mu\text{F}$  ceramic capacitance  $C_{DREF}$ . The connection path of this capacitor to the VSSA on the PCB should be kept as short as possible in order to minimize the serial resistance.

**VSSA**

VSSA is the analog ground supply pin.

**VDD**

VDD is the 3.3 V digital supply pin. A ceramic decoupling capacitor  $C_{DD} = 100 \text{ nF}$  must be placed between this pin and the VSS. Connection path of this capacitance to the VSS on the PCB should be kept as short as possible in order to minimize the serial resistance.

**VSS**

VSS is the digital ground supply pin.

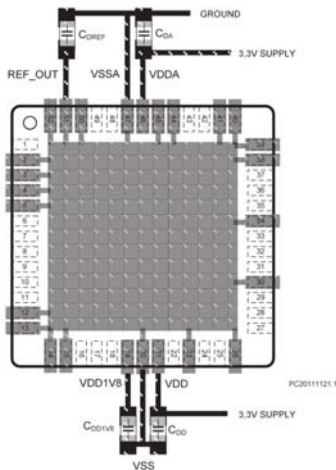

**Figure 3: Recommended Layout of the Placement of Decoupling Capacitors**

**VDD1V8**

This is an additional power supply pin to decouple an internal LDO regulator. The decoupling capacitor should be placed as close as possible to this output pin as illustrated in Figure 4.

**RX\_OUT**

RX\_OUT is the output analog pin of the receiver low noise input op-amp. This op-amp is in a negative feedback configuration.

**RX\_IN**

RX\_IN is the positive analog input pin of the receiver low noise input op-amp. Together with RX\_OUT and REF\_OUT, an active high pass filter is realized. This filter removes the main frequency (50 or 60 Hz) from the received signal. The filter characteristics are determined by external capacitors and resistors. A typical application schematic can be found in paragraph 50/60 Hz Suppression Filter.

**ZC\_IN**

ZC\_IN is the mains frequency analog input pin. The signal is used to detect the zero cross of the 50 or 60 Hz sine wave. This information is used, after filtering with the internal PLL, to synchronize frames with the mains frequency. In case of direct connection to the mains it is advised to use a series resistor of  $1 \text{ M}\Omega$  in combination with two external clamp diodes in order to limit the current flowing through the internal protection diodes.

**RX\_DATA**

RX\_DATA is a 5 V compliant open drain output. An external pull-up resistor defines the logic high level as illustrated in Figure 4. A typical value for the pull-up resistor “R” is  $10 \text{ k}\Omega$ . The signal on this output depends on the status of the data reception. If NCN49597 waits for configuration RX\_DATA outputs a pulse train with a 10 Hz frequency. After Synchronization Confirm Time out RX\_DATA = 0. If NCN49597 is searching for synchronization RX\_DATA = 1.

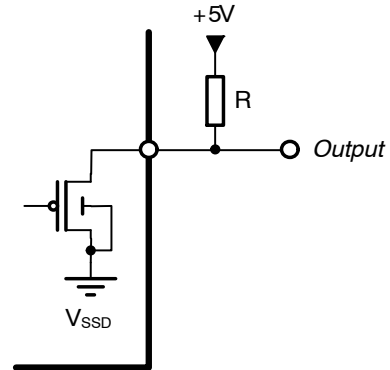

PC20090722.2

**Figure 4. Representation of 5V Safe Output**

**TDO, TDI, TCK, TMS, and TRSTB**

All these pins are part of the JTAG bus interface. The JTAG interface is used during production test of the IC and will not be described here. Input pins (TDI, TCK, TMS, and TRSTB) contain internal pull-down resistance. TDO is an output. When not used, the JTAG interface pins may be left floating.

**TXD/PRES**

TXD/PRES is the output for either the transmitting data (TX\_DATA) or a synchronization signal with the time-slots (PRE\_SLOT). TXD/PRES. More information can be found in paragraph Local Port.

**XIN**

XIN is the analog input pin of the oscillator. It is connected to the interval oscillator inverter gain stage. The clock signal can be created either internally with the external crystal and two capacitors or by connecting an external clock signal to XIN. For the internal generation case, the two external capacitors and crystal are placed as shown in Figure 5. For the external clock connection, the signal is connected to XIN and XOUT is left unused.

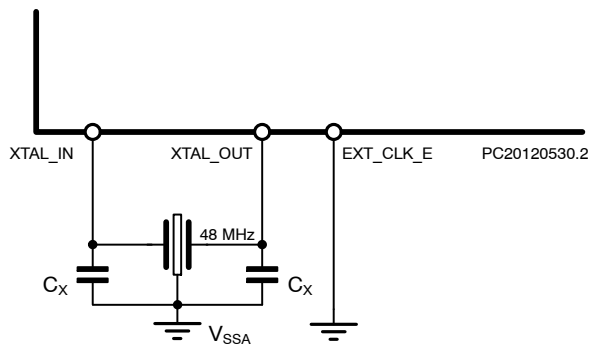

**Figure 5. Placement of the Capacitors and Crystal with Clock Signal Generated Internally**

The crystal is a classical parallel resonance crystal of 48 MHz. The values of the capacitors  $C_X$  are given by the manufacturer of the crystal. A typical value is 36 pF. The crystal has to fulfill impedance characteristics specified in the NCN49597 data sheet. As an oscillator is sensitive and precise, it is advised to put the crystal as close as possible on the board and to ground the case.

**XOUT**

XOUT is the analog output pin of the oscillator. When the clock signal is provided from an external generator, this output must be floating. When working with a crystal, this pin cannot be used directly as clock output because no additional loading is allowed on the pin (limited voltage swing).

**EXT\_CLK\_E**

EXT\_CLK\_E allows the user to connect an external clock instead of using a quartz. When this pin pulled to VDD an

external clock has to be applied to the XIN pin. When EXT\_CLK\_E is connected to VSS, the quartz oscillator is operational.

**TXD**

TXD is the digital output of the asynchronous serial communication (SCI) unit. Only half-duplex transmission is supported. It is used to realize the communication between the NCN49597 and the application microcontroller. The TXD is an open drain IO (5 V safe). External pull-up resistances (typically 10 kΩ) are necessary to generate the 5 V level. See Figure 4 for the circuit schematic.

**RXD**

This is the digital input of the asynchronous SCI unit. Only half-duplex transmission is supported. This pin supports a 5 V level. It is used to realize the communication between the NCN49597 and the application microcontroller. RXD is a 5 V safe input.

**T\_REQ**

T\_REQ is the transmission request input of the Serial Communication Interface. When pulled low its initiate a local communication from the application micro controller to NCN49597. T\_REQ is a 5 V safe input. See also paragraph Serial Communications Interface.

**BR1, BR0**

BR0 and BR1 are digital input pins. They are used to select the baud rate (bits/second) of the Serial Communication Interface unit. The rate is defined according to Table 26 BR1, BR0 Baud Rate. The values are taken into account after a reset, hardware or software. Modification of the baud rate during function is not possible. BR0 and BR1 are 5 V safe.

**CRC**

CRC is a 5 V compliant open drain output. An external pull-up resistor defines the logic high level as illustrated in Figure 4. A typical value for this pull-up resistance “R” is 10 kΩ. The signal on this output depends on the cyclic redundancy code result of the received frame. If the cyclic redundancy code is correct CRC = H during the pause between two time slots.

**RESB**

RESB is a digital input pin. It is used to perform a hardware reset of the NCN49597. This pin supports a 5 V voltage level. The reset is active when the signal is low (0 V).

**TEST**

TEST is a digital input pin with internal pull down resistor used to enable the Hardware Test Mode of the chip. When TEST is left open or forced to ground Normal Mode is enabled. When TEST is forced to VDD the Hardware Test Mode is enabled. This mode is used during production test

of the IC and will not be described here. TEST pin is not 5 V safe.

**TX\_ENB**

TX\_ENB is a digital output pin. It is low when the transmitter is activated. The signal is available to turn on the line driver. TX\_ENB is a 5 V safe with open drain output, hence a pull-up resistance is necessary achieve the requested voltage level associated with a logical one. See also Figure 4 for reference.

**TX\_OUT**

TX\_OUT is the analog output pin of the transmitter. The provided signal is the S-FSK modulated frames. A filtering operation must be performed to reduce the second and third order harmonic distortion. For this purpose an active filter is suggested. See also paragraph Transmitter Output TX\_OUT.

**ALC\_IN**

ALC\_IN is the automatic level control analog input pin. The signal is used to adjust the level of the transmitted signal. The signal level adaptation is based on the AC component. The DC level on the ALC\_IN pin is fixed internally to 1.65 V. Comparing the peak voltage of the AC signal with two internal thresholds does the adaptation of the gain. Low threshold is fixed to 0.4 V. A value under this

threshold will result in an increase of the gain. The high threshold is fixed to 0.6 V. A value over this threshold will result in a decrease of the gain. A serial capacitance is used to block the DC components. The level adaptation is performed during the transmission of the first two bits of a new frame. Eight successive adaptations are performed. See also paragraph Amplifier with Automatic Level Control (ALC).

**SCK, SDI, SDO, CSB**

These signals form the SPI interface to an optional external Flash. See Reference 1.

**SEN**

SEN is the SPI enable signal. When pulled low NCN49597 will boot from the internal program ROM. When pulled high (connected to VDD) the SPI interface is active and the IC will boot from the external Flash. Boot up sequences are described in more detail in Reference 1.

**IO0 ... IO9**

IO0 to IO9 are 10 general purpose input/output pins. When booting from ROM (SEN = VSS) IO0 ... IO2 have predefined functions: RX\_DATA, CRC and T\_REQ respectively. When booting from external Flash the user have access to all 10 of them. More information can be found in Reference 1.

**ELECTRICAL CHARACTERISTICS**

**DC and AC Characteristics**

**Oscillator: Pin XIN, XOUT**

In production the actual oscillation of the oscillator and duty cycle will not be tested. The production test will be based on the static parameters and the inversion from XIN to XOUT in order to guarantee the functionality of the oscillator.

**Table 5. OSCILLATOR**

Parameter	Test Conditions	Symbol	Min	Typ	Max	Unit
Crystal frequency	(Note 1)	f <sub>CLK</sub>	-100 ppm	48	+100 ppm	MHz
Duty cycle with quartz connected	(Note 1)		35		65	%
Start-up time	(Note 1)	T <sub>startup</sub>			15	ms
Load capacitance external crystal	(Note 1)	C <sub>L</sub>		18		pF
Series resistance external crystal	(Note 1)	R <sub>S</sub>	1	6	60	Ω
Maximum Capacitive load on XOUT	XIN used as clock input	CL <sub>XOUT</sub>			15	pF
Low input threshold voltage	XIN used as clock input	V <sub>ILXOUT</sub>	0.3 V <sub>DD</sub>			V
High input threshold voltage	XIN used as clock input	V <sub>IHXOUT</sub>			0.7 V <sub>DD</sub>	V
Low output voltage	XIN used as clock input, XOUT = 2 mA	V <sub>OLXOUT</sub>			0.3	V
High input voltage	XIN used as clock input	V <sub>OHXOUT</sub>			V <sub>DD</sub> - 0.3	V

1. Guaranteed by design. Maximum allowed series loss resistance is 80 Ω



Zero Cross Detector and 50/60 Hz PLL: Pin ZC\_IN

Table 6. ZERO CROSS DETECTOR AND 50/60 HZ PLL

Parameter	Test Conditions	Symbol	Min	Typ	Max	Unit
Maximum peak input current		$I_{mpZC\_IN}$	-20		20	mA
Maximum average input current	During 1 ms	$I_{mavgZC\_IN}$	-2		2	mA
Mains voltage (ms) range	With protection resistor at ZC_IN	$V_{MAINS}$	90		550	V
Rising threshold level	(Note 2)	$V_{IRZC\_IN}$			1.9	V
Falling threshold level	(Note 2)	$V_{IFZC\_IN}$	0.85			V
Hysteresis	(Note 2)	$V_{HYZC\_IN}$	0.4			V
Lock range for 50 Hz (Note 3)	MAINS_FREQ = 0 (50 Hz)	$F_{lock50Hz}$	45		55	Hz
Lock range for 60 Hz (Note 3)	MAINS_FREQ = 0 (60 Hz)	$F_{lock60Hz}$	54		66	Hz
Lock time (Note 3)	MAINS_FREQ = 0 (50 Hz)	$T_{lock50Hz}$			15	s
Lock time (Note 3)	MAINS_FREQ = 0 (60 Hz)	$T_{lock60Hz}$			20	s
Frequency variation without going out of lock (Note 3)	MAINS_FREQ = 0 (50 Hz)	$DF_{60Hz}$			0.1	Hz/s
Frequency variation without going out of lock (Note 3)	MAINS_FREQ = 0 (60 Hz)	$DF_{50Hz}$			0.1	Hz/s
Jitter of CHIP_CLK (Note 3)		$Jitter_{CHIP\_CLK}$	-25		25	$\mu s$

2. Measured relative to VSS

3. These parameters will not be measured in production since the performance is totally dependent of a digital circuit which will be guaranteed by the digital test patterns.

**Transmitter External Parameters: Pin TX\_OUT, ALC\_IN, TX\_ENB**

To guarantee the transmitter external specifications the TX\_CLK frequency must be 12 MHz ± 100 ppm.

**Table 7. TRANSMITTER EXTERNAL PARAMETERS**

Parameter	Test Conditions	Symbol	Min	Typ	Max	Unit
Maximum peak output level	f <sub>TX_OUT</sub> = 23 kHz f <sub>TX_OUT</sub> = 148.5 kHz Level control at max. output	V <sub>TX_OUT</sub>	0.85 0.76		1.15 1.22	Vp
Second order harmonic distortion	f <sub>TX_OUT</sub> = 148.5 kHz Level control at max. output	HD2			-55	dB
Third order harmonic distortion	f <sub>TX_OUT</sub> = 148.5 kHz Level control at max. output	HD3			-57	dB
Frequency accuracy of the generated sine wave	(Notes 4 and 6)	Df <sub>TX_OUT</sub>			30	Hz
Capacitive output load at pin TX_OUT	(Note 4)	CL <sub>TX_OUT</sub>			20	pF
Resistive output load at pin TX_OUT		RL <sub>TX_OUT</sub>	5			kΩ
Turn off delay of TX_ENB output	(Note 5)	Td <sub>TX_ENB</sub>	0.25		0.5	ms
Automatic level control attenuation step		ALC <sub>step</sub>	2.9		3.1	dB
Maximum attenuation		ALC <sub>range</sub>	20.3		21.7	dB
Low threshold level on ALC_IN		V <sub>TL</sub> <sub>ALC_IN</sub>	0.46		0.34	V
High threshold level on ALC_IN		V <sub>TH</sub> <sub>ALC_IN</sub>	0.72		0.54	V
Input impedance of ALC_IN pin		R <sub>ALC_IN</sub>	111		189	kΩ
Power supply rejection ration of the transmitter section		PSRR <sub>TX_OUT</sub>	10 (Note 7) 32 (Note 8)			dB

4. This parameter will not be tested in production.
5. This delay corresponds to the internal transmit path delay and will be defined during design.
6. Taking into account the resolution of the DDS and an accuracy of 100ppm of the crystal.
7. A sinusoidal signal of 10 kHz and 100 mVpp is injected between VDDA and VSSA. The digital AD converter generates an idle pattern. The signal level at TX\_OUT is measured to determine the parameter.
8. A sinusoidal signal of 50 Hz and 100 mVpp is injected between VDDA and VSSA. The digital AD converter generates an idle pattern. The signal level at TX\_OUT is measured to determine the parameter.

The LPF filter + amplifier must have a frequency characteristic between the limits listed below. The absolute output level depends on the operating condition. In production the measurement will be done for relative output levels where the 0 dB reference value is measured at 50 kHz with a signal amplitude of 100 mV.

**Table 8. TRANSMITTER FREQUENCY CHARACTERISTICS**

Frequency (kHz)	Attenuation		Unit
	Min	Max	
10	-0.5	0.5	dB
148.5	-1.3	0.5	dB
195	-4.5	-2.0	dB
245		-3.0	dB
500		-18.0	dB
1000		-36.0	dB
2000		-50	dB

Receiver External Parameters: Pin RX\_IN, RX\_OUT, REF\_OUT

Table 9. RECEIVER EXTERNAL PARAMETERS

Parameter	Test Conditions	Symbol	Min	Typ	Max	Unit
Input offset voltage 42 dB	AGC gain = 42 dB	V <sub>OFFS_RX_IN</sub>			5	mV
Input offset voltage 0 dB	AGC gain = 0 dB	V <sub>OFFS_RX_IN</sub>			50	mV
Max. peak input voltage (corresponding to 62.5% of the SD full scale)	AGC gain = 0 dB (Note 9)	V <sub>MAX_RX_IN</sub>	0.85		1.15	Vp
Input referred noise of the analog receiver path	AGC gain = 42 dB (Notes 9 and 10)	NF <sub>RX_IN</sub>			150	nV/√Hz
Input leakage current of receiver input		I <sub>LE_RX_IN</sub>	-1		1	μA
Max. current delivered by REF_OUT		I <sub>Max_REF_OUT</sub>	-300		300	mA
Power supply rejection ratio of the receiver input section	AGC gain = 42 dB (Note 11)	PSRR <sub>LPF_OUT</sub>	10			dB
	AGC gain = 42 dB (Note 12)		35			
AGC gain step		AGC <sub>step</sub>	5.5		6.5	dB
AGC range		AGC <sub>range</sub>	39.9		44.1	dB
Analog ground reference output voltage		V <sub>REF_OUT</sub>	1.52		1.78	V
Signal to noise ratio at 62.5 % of the SD full scale	(Notes 9 and 13)	SN <sub>AD_OUT</sub>	54			dB
Clipping level at the output of the gain stage (RX_OUT)		V <sub>CLIP_AGC_IN</sub>	1.05		1.65	Vp

9. Input at RX\_IN, no other external components.

10. Characterization data only. Not tested in production.

11. A sinusoidal signal of 10 kHz and 100 mVpp is injected between VDDA and VSSA. The signal level at the differential LPF\_OUT and REF\_OUT output is measured to determine the parameter.

12. A sinusoidal signal of 50 Hz and 100 mVpp is injected between VDDA and VSSA. The signal level at the differential LPF\_OUT output is measured to determine the parameter.

13. These parameters will be tested in production with an input signal of 95 kHz and 1 Vp by reading out the digital samples at the point AD\_OUT with the default settings of T\_RX\_MOD[7], SDMOD\_TYP, DEC\_TYP, and COR\_F\_ENA. The AGC gain is switched to 0 dB.

The receive LPF filter + AGC + low noise amplifier must have a frequency characteristic between the limits listed below. The absolute output level depends on the operating condition.

Table 10. RECEIVER FREQUENCY CHARACTERISTICS

Frequency (kHz)	Attenuation		Unit
	Min	Max	
10	-0.5	0.5	dB
148.5	-1.3	0.5	dB
195	-4.5	-2.0	dB
245		-3.0	dB
500		-18.0	dB
1000		-36.0	dB
2000		-50	dB

**Power-on-Reset (POR)**

**Table 11. POWER-ON-RESET**

Parameter	Test Conditions	Symbol	Min	Typ	Max	Unit
POR threshold		$V_{POR}$	2.1		2.7	V
Power supply rise time	0 to 3V	$T_{RPOR}$	1			ms

**Digital Outputs: TDO, CLK\_OUT**

**Table 12. DIGITAL OUTPUTS: TDO, CLK\_OUT**

Parameter	Test Conditions	Symbol	Min	Typ	Max	Unit
Low output voltage	$I_{XOUT} = 3 \text{ mA}$	$V_{OL}$			0.4	V
High output voltage	$I_{XOUT} = -3 \text{ mA}$	$V_{OH}$	$0.85 V_{DD}$			V

**Digital Outputs with Open Drain: TX\_ENB, TXD**

**Table 13. DIGITAL OUTPUTS WITH OPEN DRAIN: TX\_ENB, TXD, RX\_DATA, CRC, T\_REQ**

Parameter	Test Conditions	Symbol	Min	Typ	Max	Unit
Low output voltage	$I_{XOUT} = 4 \text{ mA}$	$V_{OL}$			0.4	V

**Digital Inputs: BR0, BR1**

**Table 14. DIGITAL INPUTS: BR0, BR1**

Parameter	Test Conditions	Symbol	Min	Typ	Max	Unit
Low input level		$V_{IL}$			$0.2 V_{DD}$	V
High input level	0 to 3 V	$V_{IH}$	$0.8 V_{DD}$			V
Input leakage current		$I_{LEAK}$	-10		10	$\mu\text{A}$

**Digital Inputs with Pull Down: TDI, TMS, TCK, TRSTB, TEST**

**Table 15. DIGITAL INPUTS WITH PULL DOWN: TDI, TMS, TCK, TRSTB, TEST**

Parameter	Test Conditions	Symbol	Min	Typ	Max	Unit
Low input level		$V_{IL}$			$0.2 V_{DD}$	V
High input level		$V_{IH}$	$0.8 V_{DD}$			V
Pull down resistor	(Note 14)	$R_{PU}$	7		50	$k\Omega$

14. Measured around a bias point of  $V_{DD}/2$ .

**Digital Schmitt Trigger Inputs: RXD, RESB**

**Table 16. DIGITAL SCHMITT TRIGGER INPUTS: RXD, RESB**

Parameter	Test Conditions	Symbol	Min	Typ	Max	Unit
Rising threshold level		$V_{T+}$			$0.80 V_{DD}$	V
Falling threshold level		$V_{T-}$	$0.2 V_{DD}$			V
Input leakage current		$I_{LEAK}$	-10		10	$\mu\text{A}$

Current Consumption

Table 17. CURRENT CONSUMPTION

Parameter	Test Conditions	Symbol	Min	Typ	Max	Unit
Current consumption in receive mode	Current through $V_{DD}$ and $V_{DDA}$ (Note 15)	$I_{RX}$			60	mA
Current consumption in transmit mode	Current through $V_{DD}$ and $V_{DDA}$ (Note 15)	$I_{TX}$			60	mA
Current consumption when RESB = 0	Current through $V_{DD}$ and $V_{DDA}$ (Note 15)	$I_{RESET}$			4	mA

15.  $f_{CLK} = 48$  MHz.

INTRODUCTION

General Description

The NCN49597 is a single chip half duplex S-FSK modem dedicated to power line carrier (PLC) data transmission on low- or medium-voltage power lines. The device offers complete handling of the protocol layers from the physical up to the MAC. NCN49597 complies with the CENELEC EMC standard EN 50065-1 and the IEC 61334-5-1 standards. It operates from a single 3.3 V power supply and is interfaced to the power line by an external power driver and transformer. An internal PLL is locked to the mains frequency and is used to synchronize the data transmission at data rates of 300, 600, 1200, 2400 and 4800 baud for a 50 Hz mains frequency, or 360, 720, 1440, 2880 and 5760 baud for a 60 Hz mains frequency. In both cases this corresponds to 3, 6, 12 or 24 data bits per half cycle of the mains period.

S-FSK is a modulation and demodulation technique that combines some of the advantages of a classical spread spectrum system (e.g. immunity against narrow band interferers) with the advantages of the classical FSK system (low complexity). The transmitter assigns the space frequency  $f_s$  to “data 0” and the mark frequency  $f_m$  to “data 1”. The difference between S-FSK and the classical FSK lies in the fact that  $f_s$  and  $f_m$  are now placed far from each other, making their transmission quality independent from each other (the strengths of the small interferences and the signal attenuation are both independent at the two frequencies). The frequency pairs supported by the NCN49597 are in the range of 9 – 150 kHz with a typical separation of 10 kHz.

The conditioning and conversion of the signal is performed at the analog front-end of the circuit. The further processing of the signal and the handling of the protocol is

digital. At the back-end side, the interface to the application is done through a serial interface. The digital processing of the signal is partitioned between hardwired blocks and a microprocessor block. The microprocessor is controlled by firmware. Where timing is most critical, the functions are implemented with dedicated hardware. For the functions where the timing is less critical, typically the higher level functions, the circuit makes use of the ARM microprocessor core.

The processor runs DSP algorithms and, at the same time, handles the communication protocol. The communication protocol, in this application, contains the MAC = Medium Access Control Layer. The program running on the microprocessor is stored into ROM. The working data necessary for the processing is stored in an internal RAM. At the back-end side the link to the application hardware is provided by a Serial Communication Interface (SCI). The SCI is an easy to use serial interface, which allows communication between an external processor used for the application software and the NCN49597 modem. The SCI works on two wires: TXD and RXD. Baud rate is programmed by setting 2 bits (BR0, BR1).

Because the low protocol layers are handled in the circuit, the NCN49597 provides an innovative architectural split. Thanks to this, the user has the benefit of a higher level interface of the link to the PLC medium. Compared to an interface at the physical level, the NCN49597 allows faster development of applications. The user just needs to send the raw data to the NCN49597 and no longer has to take care of the protocol detail of the transmission over the specific medium. This last part represents usually 50% of the software development costs.

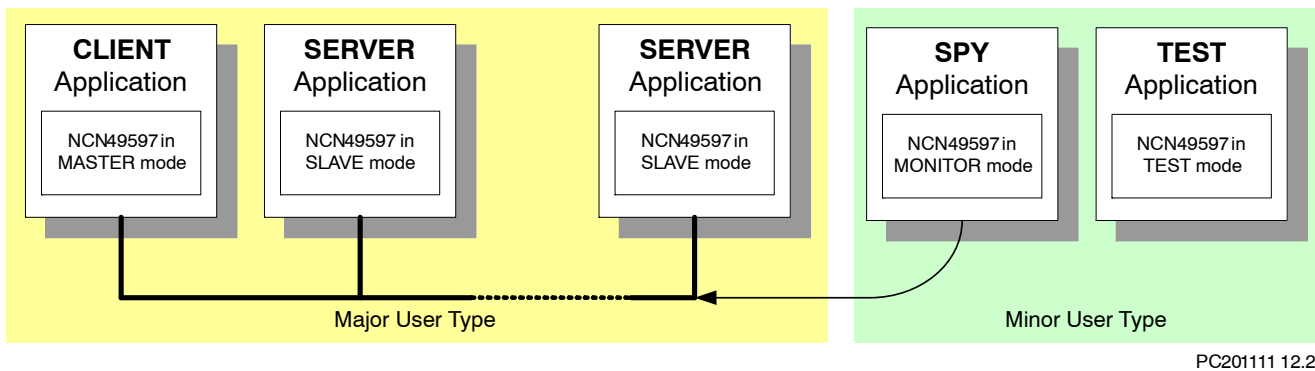

PC201111 12.2

**Figure 6. Application Examples**

NCN49597 is intended to connect equipment using Distribution Line Carrier (DLC) communication. It serves two major and two minor types of applications:

- Major types:
  - ◆ Master or Client:
    - A Master is a client to the data served by one or many slaves on the power line. It collects data from and controls the slave devices. A typical application is a concentrator system
  - ◆ Slave or Server:
    - A Slave is a server of the data to the Master. A typical application is an electricity meter equipped with a PLC modem.
- Minor type:
  - ◆ Spy or Monitor:
    - Spy or Monitor mode is used to only listen to the data that comes across the power line. Only the physical layer frame correctness is checked. When the frame is correct, it is passed to the external processor.
  - ◆ Test Mode:
    - The Software Test Mode is used to test the compliance of a PLC modem conforms to CENELEC. EN 50065-1 by a continuous broadcast of  $f_S$  or  $f_M$ .

**Functional Description**

The block diagram below represents the main functional units of the NCN49597:

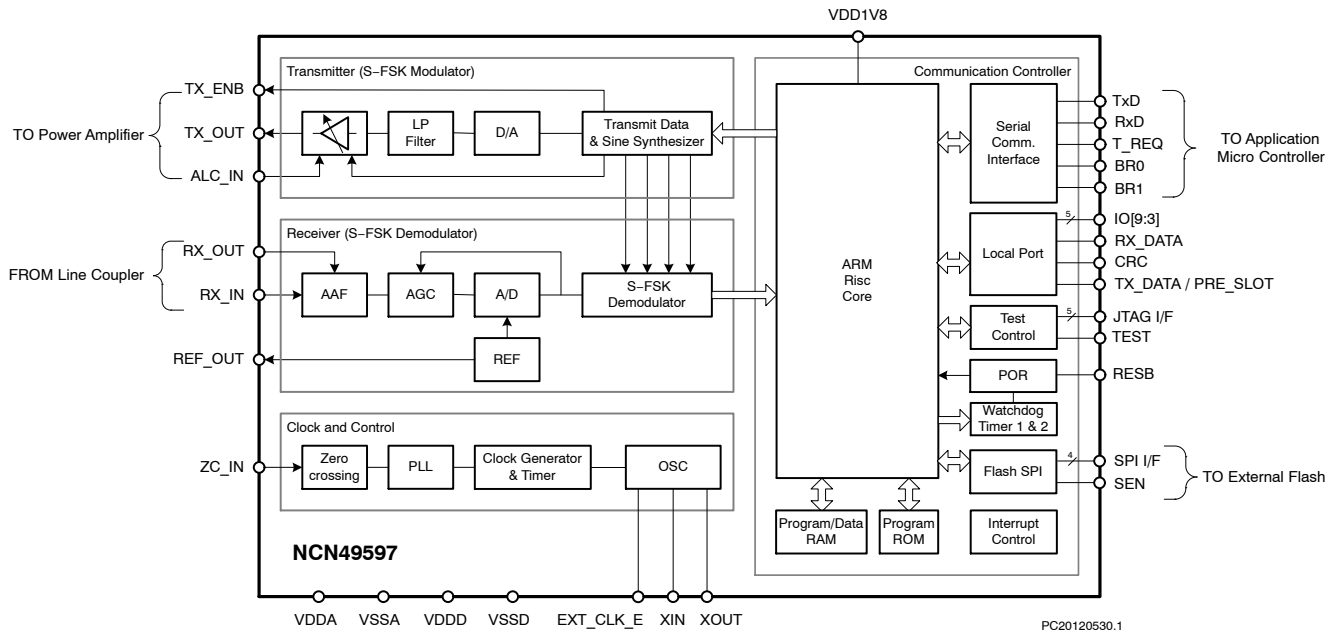

**Figure 7. S-FSK Modem NCN49597 Block Diagram**

**Transmitter**

The NCN49597 Transmitter function block prepares the communication signal which will be sent on the transmission channel during the transmitting phase. This block is connected to a power amplifier which injects the output signal on the mains through a line-coupler.

**Receiver**

The analog signal coming from the line-coupler is low pass filtered in order to avoid aliasing during the conversion. Then the level of the signal is automatically adapted by an automatic gain control (AGC) block. This operation maximizes the dynamic range of the incoming signal. The signal is then converted to its digital representation using sigma delta modulation. From then on, the processing of the data is done in a digital way. By using dedicated hardware, a direct quadrature demodulation is performed. The signal demodulated in the base band is then low pass filtered to reduce the noise and reject the image spectrum.

**Clock and Control**

According to the IEC 61334-5-1 standard, the frame data is transmitted at the zero cross of the mains voltage. In order to recover the information at the zero cross, a zero cross detection of the mains is performed. A phase-locked loop (PLL) structure is used in order to allow a more reliable reconstruction of the synchronization. This PLL permits as well a safer implementation of the "repetition with credit" function (also known as chorus transmission). The clock generator makes use of a precise quartz oscillator master. The clock signals are then obtained by the use of a programmed division scheme. The support circuits are also contained in this block. The support circuits include the necessary blocks to supply the references voltages for the AD and DA converters, the biasing currents and power supply sense cells to generate the right power off and startup conditions.

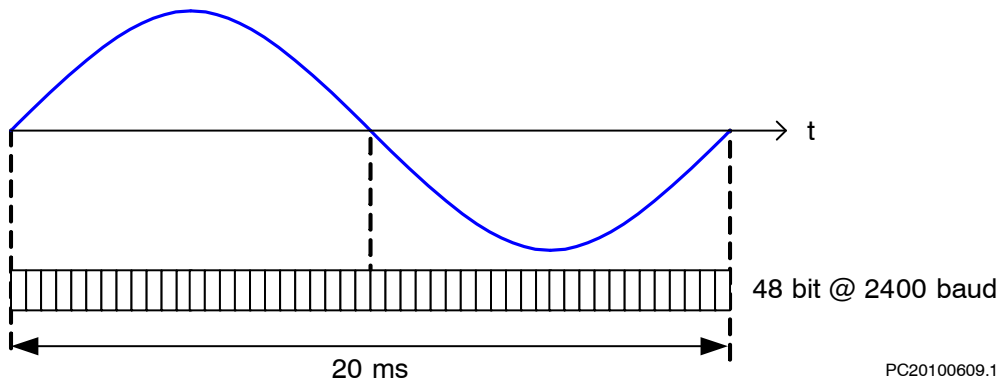

Figure 8. Data Stream is in Sync with Zero Cross of the Mains (example for 50 Hz)

**Communication Controller**

The Communication Controller block includes the micro-processor, its peripherals: RAM, ROM, UART, TIMER, and the Power on reset. The processor uses the ARM Reduced Instruction Set Computer (RISC) architecture optimized for IO handling. For most of the instructions, the machine is able to perform one instruction per clock cycle. The microcontroller contains the necessary hardware to implement interrupt mechanisms, timers and is able to perform byte multiplication over one instruction cycle. The microcontroller is programmed to handle the physical layer (chip synchronization), and the MAC layer conform to IEC 61334-5-1. The program is stored in a masked ROM. The RAM contains the necessary space to store the working data. The back-end interface is done through the Serial Communication Interface block. This back-end is used for data transmission with the application micro controller (containing the application layer for concentrator, power meter, or other functions) and for the definition of the modem configuration.

**Local Port**

The controller uses 3 output ports to inform about the actual status of the PLC communication. RX\_DATA indicates if Receiving is in progress, or if NCN49597 is waiting for synchronization, or of it configures. CRC indicates if the received frames are valid (CRC = OK). TXD/PRES is the output for either the transmitting data (TX\_DATA) or a synchronization signal with the time-slots (PRE\_SLOT).

**Serial Communication Interface**

The local communication is a half duplex asynchronous serial link using a receiving input (RxD) and a transmitting output (TxD). The input port T\_REQ is used to manage the local communication with the application micro controller and the baud rate can be selected depending on the status of two inputs BR0, BR1. These two inputs are taken in account after an NCN49597 reset. Thus when the application micro controller wants to change the baud rate, it has to set the two inputs and then provoke a reset.

**DETAILED HARDWARE DESCRIPTION**

**Clock and Control**

According to the IEC 61334-5-1 standard, the frame data is transmitted at the zero cross of the mains voltage. In order to recover the information at the zero cross, a zero cross detection of the mains is performed. A phase-locked loop (PLL) structure is used in order to allow a more reliable reconstruction of the synchronization. The output of this

block is the clock signal CHIP\_CLK, 8 times over sampled with the bit rate. The oscillator makes use of precise 48 MHz quartz. This clock signal together with CHIP\_CLK is fed into the Clock Generator and time block. Here several internal clock signals and timings are obtained by the use of a programmed division scheme.



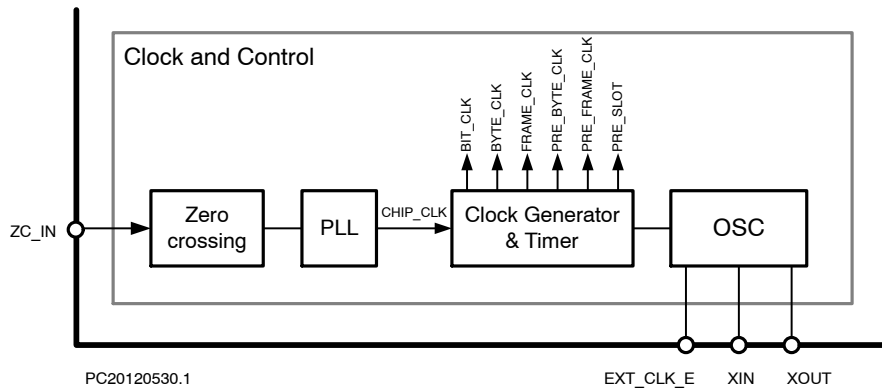

Figure 9. Clock and Control Block

**Zero Cross Detector**

ZC\_IN is the mains frequency analog input pin. The signal is used to detect the zero cross of the 50 or 60 Hz sine wave. This information is used, after filtering with the internal PLL, to synchronize frames with the mains frequency. In

case of direct connection to the mains it is advised to use a series resistor of 1 MΩ in combination with two external Schottky clamp diodes in order to limit the current flowing through the internal protection diodes.

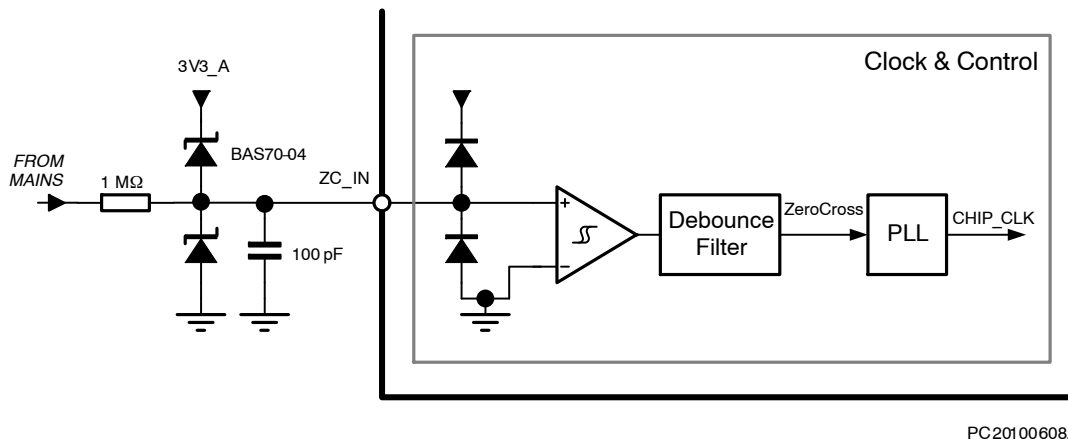

Figure 10. Zero Cross Detector with Falling Edge De-bounce Filter

The zero cross detector output is logic zero when the input is lower than the falling threshold level and a logic one when the input is higher than the rising threshold level. The falling

edges of the output of the zero cross detector are de-bounced by a period between 0.5 ms and 1 ms. The Rising edges are not de-bounced.

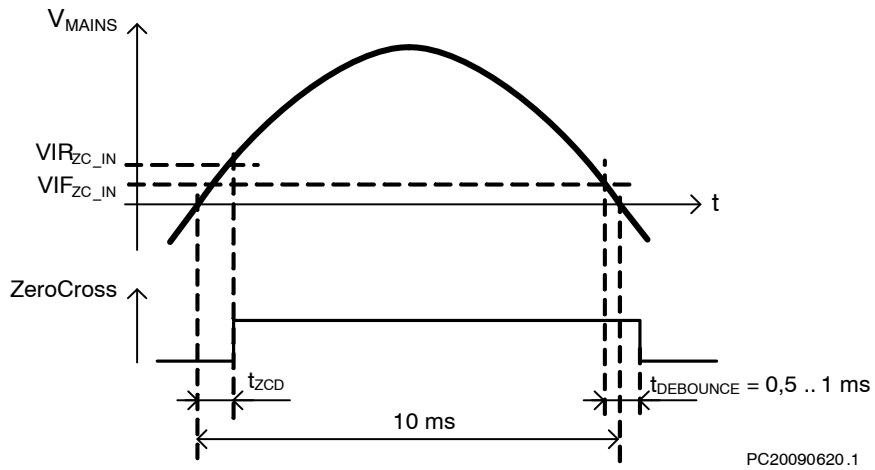

Figure 11. Zero Cross Detector Signals and Timing (example for 50 Hz)

**50/60 Hz PLL**

The output of the zero cross detector is used as an input for a PLL. The PLL generates the clock CHIP\_CLK which is 8 times the bit rate and which is in phase with the rising edge

crossings. The PLL locks on the zero cross from negative to positive phase. The bit rate is always an even multiple of the mains frequency, so following combinations are possible:

**Table 18. CHIP\_CLK IN FUNCTION OF SELECTED BAUD RATE AND MAINS FREQUENCY**

BAUD[1:0]	MAINS_FREQ	Baudrate	CHIP_CLK
00	50 Hz	300	2400 Hz
01		600	4800 Hz
10		1200	9600 Hz
11		2400	19200 Hz
00	60 Hz	360	2880 Hz
01		720	5760 Hz
10		1440	11520 Hz
11		2880	23040 Hz

In case no zero crossings are detected the PLL freezes its internal timers in order to maintain the CHIP\_CLK timing.

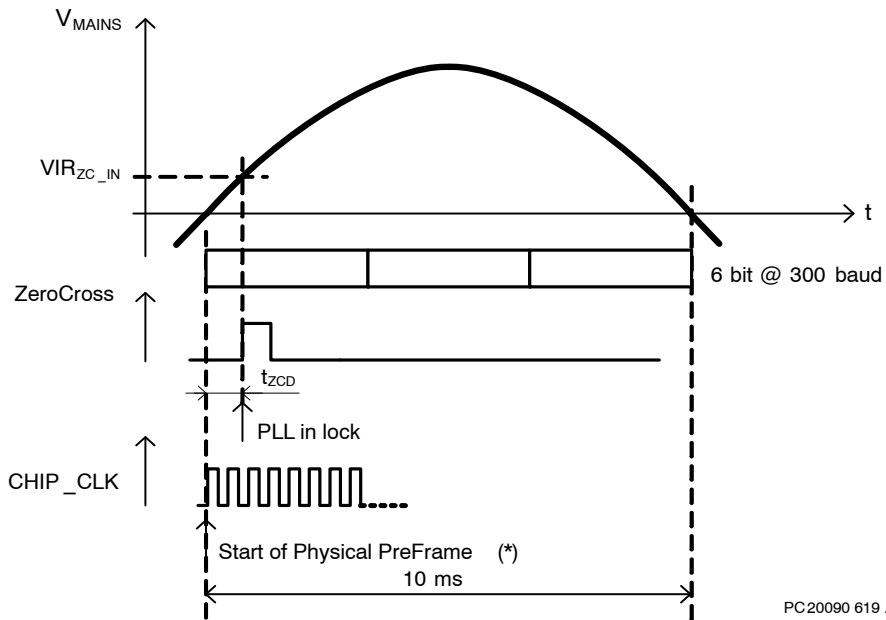

\*The start of the Physical Subframe is shifted back with  $R\_ZC\_ADJUST[7:0] \times 13 \mu S = t_{ZCD}$  to compensate for the zero cross delay.

**Figure 12. Zero Cross Adjustment to Compensate for Zero Cross Delay (example for 50 Hz)**

The phase difference between the zero cross of the mains and CHIP\_CLK can be tuned. This opens the possibility to compensate for external delay  $t_{ZCD}$  (e.g. opto coupler) and for the 1.9 V positive threshold  $V_{IRZC\_IN}$  of the zero cross detector. This is done by pre-loading the PLL counter with

a number value stored in register  $R\_ZC\_ADJUST[7:0]$ . The adjustment period or granularity is  $13 \mu s$ . The maximum adjustment is  $255 \times 13 \mu s = 3.32 \text{ ms}$  which corresponds with  $1/6^{\text{th}}$  of the 50 Hz mains sine period.

**Table 19. ZERO CROSS DELAY COMPENSATION**

R_ZC_ADJUST[7:0]	Compensation
0000 0000	0 $\mu s$
0000 0001	13 $\mu s$
0000 0010	26 $\mu s$
0000 0011	39 $\mu s$
...	...
1111 1101	3289 $\mu s$
1111 1110	3302 $\mu s$
1111 1111	3315 $\mu s$

**Oscillator**

The oscillator works with a standard parallel resonance crystal of 48 MHz. XIN is the input to the oscillator inverter gain stage and XOUT is the output.

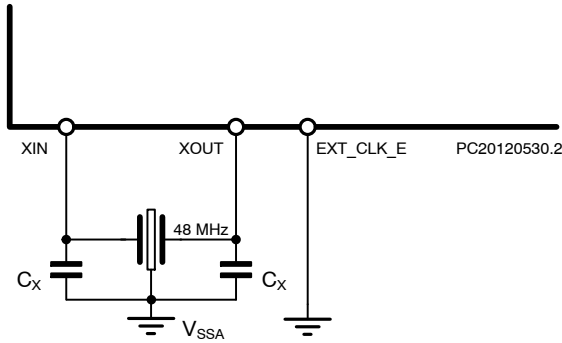

**Figure 13. Placement of the Capacitors and Crystal with Clock Signal Generated Internally**

For correct functionality the external circuit illustrated in Figure 13 must be connected to the oscillator pins. For a crystal requiring a parallel capacitance of 18 pF C<sub>x</sub> must be around 36 pF. (Values of capacitors are indicative only and are given by the crystal manufacturer). To guarantee startup

the series loss resistance of the crystal must be smaller than 60 Ω. EXT\_CLK\_E should be strapped to V<sub>SSA</sub>. If an external clock of 48 MHz is used, this signal should be connected to XIN and EXT\_CLK\_E needs to be pulled to V<sub>DD</sub>.

The oscillator output f<sub>CLK</sub> = 48 MHz is the base frequency for the complete IC. The clock frequency for the ARM f<sub>ARM</sub> = f<sub>CLK</sub>. The clock for the transmitter, f<sub>TX\_CLK</sub> is equal to f<sub>CLK</sub> / 4 or 12 MHz. All the transmitter internal clock signals will be derived from f<sub>TX\_CLK</sub>. The clock for the receiver, f<sub>RX\_CLK</sub> is equal to f<sub>CLK</sub> / 8 or 6 MHz. All the receiver internal clock signals will be derived from f<sub>RX\_CLK</sub>.

**Clock Generator and Timer**

The CHIP\_CLK and f<sub>CLK</sub> are used to generate a number of timing signals used for the synchronization and interrupt generation. The timing generation has a fixed repetition rate which corresponds to the length of a physical subframe. (see paragraph Reference 1)

The timing generator is the same for transmit and receive mode. When NCN49597 switches from receive to transmit and back from transmit to receive, the R\_CHIP\_CNT counter value is maintained. As a result all timing signals for receive and transmit have the same relative timing. The following timing signals are defined as:

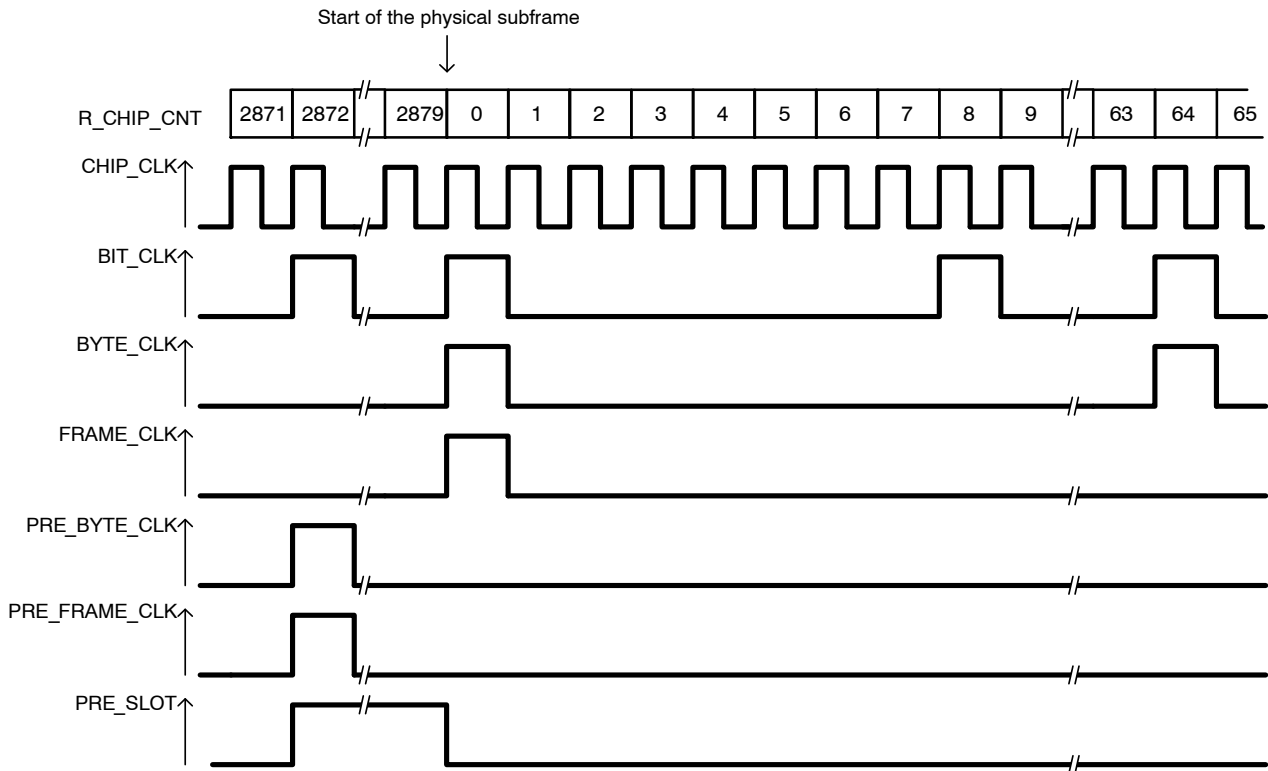

**Figure 14. Timing Signals**

PC20090619.1

**CHIP\_CLK:** is the output of the PLL and 8 times the bit rate on the physical interface. See also paragraph **50/60 Hz PLL**.

**BIT\_CLK:** is active at counter values 0, 8, 16, .. 2872 and inactive at all other counter values. This signal is used to indicate the transmission of a new bit.

**BYTE\_CLK:** is active at counter values 0, 64, 128, .. 2816 and inactive at all other counter values. This signal is used to indicate the transmission of a new byte.

**FRAME\_CLK:** is active at counter values 0 and inactive at all other counter values. This signal is used to indicate the transmission or reception of a new frame.

**PRE\_BYTE\_CLK** is a signal which is 8 CHIP\_CLK sooner than BYTE\_CLK. This signal is used as an interrupt for the internal microcontroller and indicates that a new byte for transmission must be generated.

**PRE\_FRAME\_CLK** is a signal which is 8 CHIP\_CLK sooner than FRAME\_CLK. This signal is used as an interrupt for the internal microcontroller and indicates that a new frame will start at the next FRAME\_CLK.

**PRE\_SLOT** is logic 1 between the rising edge of PRE\_FRAME\_CLK and the rising edge of FRAME\_CLK. This signal can be provided at the digital output pin

TXD/PRES when R\_CONF[7] = 0 (See paragraph Local Port and Table 25, field R\_CONF\_TXD\_PRES\_SEL) and can be used by the external host controller to synchronize its software with the FRAME\_CLK of NCN49597.

**Transmitter Path Description (S-FSK Modulator)**

For the generation of the space and mark frequencies, the direct digital synthesis (DDS) of the sine wave signals is performed under the control of the microprocessor. After a signal conditioning step, a digital to analog conversion is performed. As for the receive path, a sigma delta modulation technique is used. In the analog domain, the signal is low pass filtered, in order to remove the high frequency quantization noise, and passed to the automatic level controller (ALC) block, where the level of the transmitted signal can be adjusted. The determination of the signal level is done through the sense circuitry.

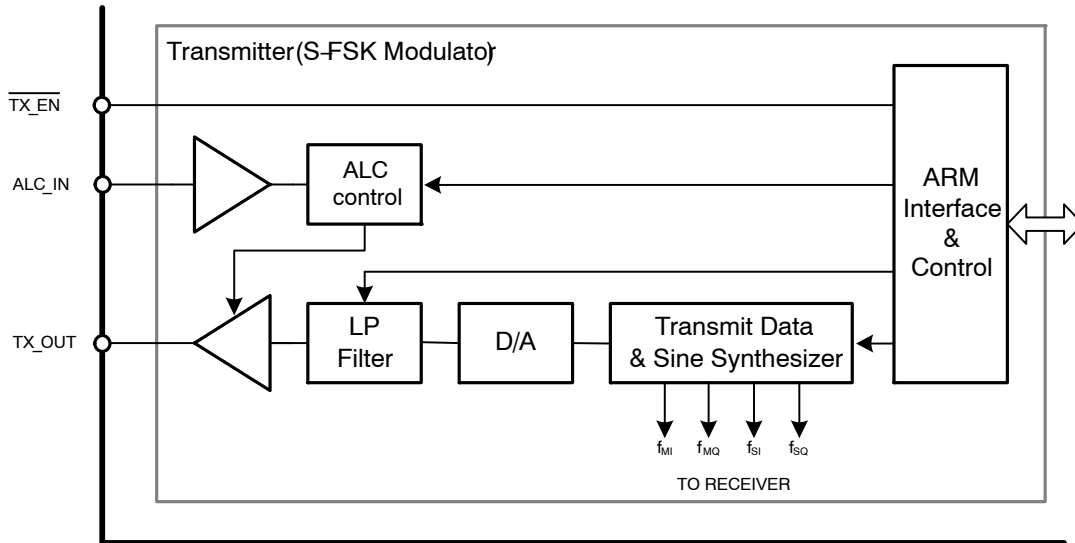

Figure 15. Transmitter Block Diagram

**ARM Interface and Control**

The interface with the ARM consists in a 8-bit data registers R\_TX\_DATA, 2 control registers R\_TX\_CTRL and R\_ALC\_CTRL, a flag TX\_RXB defining transmit and receive and 2 16-bit wide frequency step registers R\_FM and R\_FS defining  $f_M$  (mark frequency = data 1) and  $f_S$  (space frequency = data 0). All these registers are memory mapped. Some of them are for internal use only and cannot be accessed by the user.

Processing of the physical frame (preamble, MAC address, CRC) is done by the ARM.

**Sine Wave Generator**

A sine wave is generated with a direct digital synthesizer DDS. The synthesizer generates in transmission mode a sine wave either for the space frequency ( $f_S$ , data 0) or for the mark frequency ( $f_M$ , data 1). In reception the synthesizer generates the sine and cosine waves for the mixing process,  $f_{SI}$ ,  $f_{SQ}$ ,  $f_{MI}$ ,  $f_{MQ}$  (space and mark signals in phase and quadrature). The space and mark frequencies are defined in an individual step 16 bit wide register.

Table 20. FS AND FM STEP REGISTERS

ARM Register	Hard Reset	Soft Reset	Description
R_FS[15:0]	0000h	0000h	Step register for the space frequency $f_S$
R_FM[15:0]	0000h	0000h	Step register for the mark frequency $f_M$

The space and mark frequency can be calculated as:

- $f_S = R\_FS[15:0]_{dec} \times f_{DDS}/2^{18}$
- $f_M = R\_FM[15:0]_{dec} \times f_{DDS}/2^{18}$

Or the content of both R\_FS[15:0] and R\_FM[15:0] are defined as:

- $R\_FS[15:0]_{dec} = Round(2^{18} \times f_S/f_{DDS})$
- $R\_FM[15:0]_{dec} = Round(2^{18} \times f_M/f_{DDS})$ 
  - ◆ Where  $f_{DDS} = 3\text{ MHz}$  is the direct digital synthesizer clock frequency.

After a hard or soft reset or at the start of the transmission (when TX\_RXB goes from 0 to 1) the phase accumulator must start at its 0 phase position, corresponding with a 0 V output level. When switching between  $f_M$  and  $f_S$  the phase accumulator must give a continuous phase and not restart from phase 0

When NCN49597 goes into receive mode (when TX\_RXB goes from 1 to 0) the sine wave generator must make sure to complete the active sine period.

The control logic for the transmitter generates a signal TX\_ENB to enable the external power amplifier. TX\_ENB is 1 when the NCN49597 is in receive mode. TX\_ENB is 0 when NCN49597 is in transmit mode. When going from transmit to receive mode (TX\_RXB goes from 1 to 0) the TX\_ENB signal is kept active for a short period of  $t_{dTX\_ENB}$ .

The control logic for the transmitter generates a signal TX\_DATA which corresponds to the transmitted S-FSK signal. When transmitting  $f_M$  TX\_DATA is logic 1. When transmitting  $f_S$  TX\_DATA is logic 0. When the transmitter is not enabled (TX\_RXB = 0) TX\_DATA goes to logic 1 at the next BIT\_CLK.

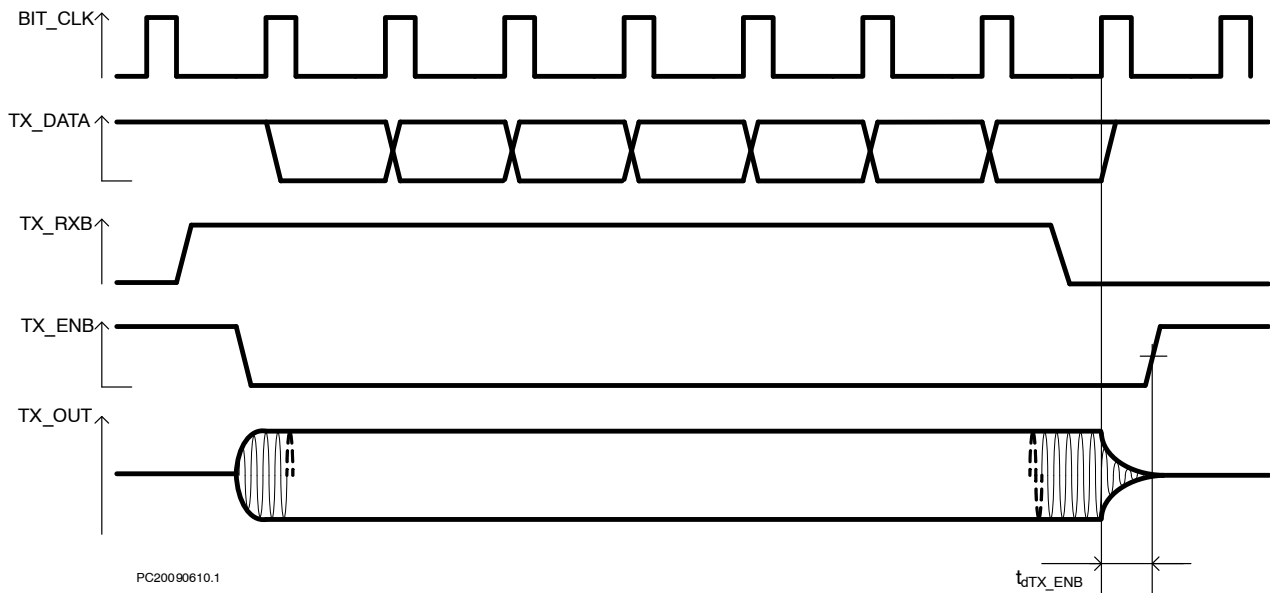

Figure 16. TX\_ENB Timing

**DA Converter**

A digital to analog  $\Sigma\Delta$  converter converts the sine wave digital word to a pulse density modulated (PDM) signal. The PDM signal is converted to an analog signal with a first order switched capacitor filter.

**Low Pass Filter**

A 3<sup>rd</sup> order continuous time low pass filter in the transmit path filters the quantization noise and noise generated by the  $\Sigma\Delta$  DA converter. The typical corner frequency  $f_{-3dB} = 138\text{ kHz}$  and is internally trimmed to compensate for process variation. This filter can be tuned to  $f_{-3dB} = 1508\text{ kHz}$  as described in Reference 1.

**Amplifier with Automatic Level Control (ALC)**

The pin ALC\_IN is used for level control of the transmitter output level. First peak detection is done. The peak value is compared to two thresholds levels:  $V_{TL\_ALC\_IN}$  and  $V_{TH\_ALC\_IN}$ . The result of the peak

detection is used to control the setting of the level of TX\_OUT. The level of TX\_OUT can be attenuated in 8 steps of 3 dB typical.

After hard or soft reset the level is set at minimum level (maximum attenuation) When going to reception mode (when TX\_RXB goes from 1 to 0) the level is kept in memory so that the next transmit frame starts with the old level. The evaluation of the level is done during 1 CHIP\_CLK period.

Depending on the value of peak level on ALC\_IN the attenuation is updated:

- $V_{PALC\_IN} < V_{TL\_ALC}$ : increase the level with one 6 dB step
- $V_{TL\_ALC} \leq V_{PALC\_IN} \leq V_{TH\_ALC}$ : don't change the level
- $V_{PALC\_IN} > V_{TH\_ALC}$ : decrease the level with one 6 dB step

The gain changes in the next CHIP\_CLK period.

An evaluation phase and a level adjustment take 2 CHIP\_CLK periods. ALC operation is enabled only during the first 16 CHIP\_CLK cycles after a hard or soft reset or after going into transmit mode.

The automatic level control can be disabled by setting register R\_ALC\_CTRL[3] = 1. In this case the transmitter output level is fixed to the programmed level in the register R\_ALC\_CTRL[2:0]. See Reference 1.

**Table 21. FIXED TRANSMITTER OUTPUT ATTENUATION**

ALC_CTRL[2:0]	Attenuation
000	0 dB
001	-3 dB
010	-6 dB
011	-9 dB
100	-12 dB
101	-15 dB
110	-18 dB
111	-21 dB

**Transmitter Output TX\_OUT**

The transmitter output is DC coupled to the TX\_OUT pin. Because the complete analog part of NCN49597 is referenced to the analogue ground REF\_OUT, a decoupling capacitor C<sub>1</sub> is needed when connecting NCN49597 to

external circuitry working with another ground. To suppress the second and third order harmonic of the generated S-FSK signal it is recommended to use a 2<sup>nd</sup> or 4<sup>th</sup> order low pass filter. In Figure 17 a MFB topology of a 2<sup>nd</sup> order filter is illustrated.

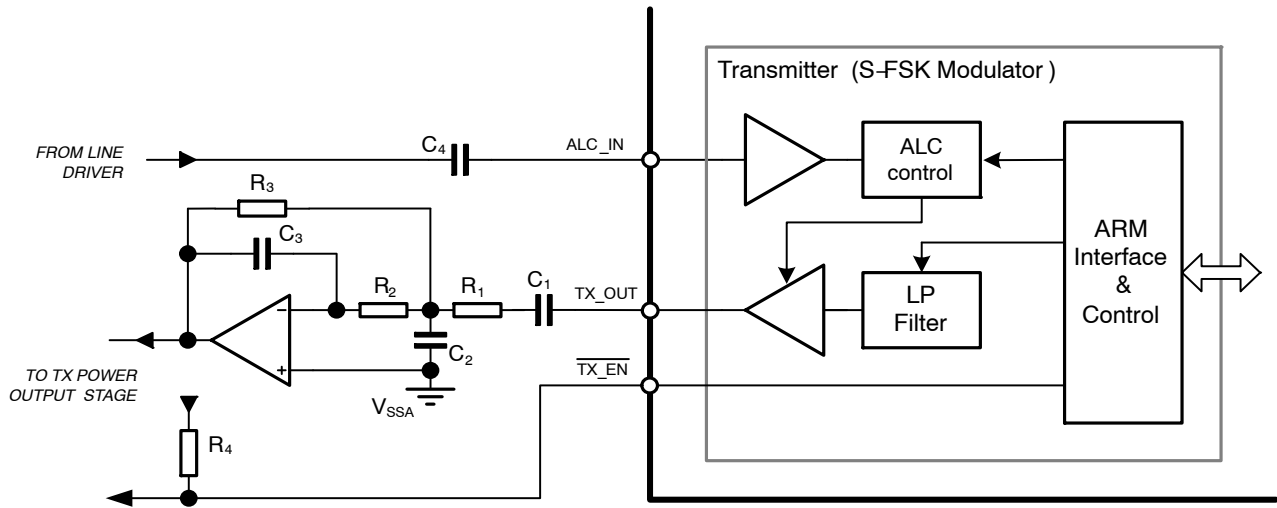

**Figure 17. TX\_OUT Filter**

PC20091216.1

**Receiver Path Description**

**Receiver Block Diagram**

The receiver takes in the analog signal from the line coupler, conditions it and demodulates it in a data-stream to the communication controller. The operation mode and the baud rate are made according to the setting in R\_CONF, R\_FS and R\_FM. The receive signal is applied first to a high pass filter. Therefore NCN49597 has a low noise operational amplifier at the input stage which can be used to make a high

pass active filter to attenuate the mains frequency. This high pass filter output is followed by a gain stage which is used in an automatic gain control loop. This block also performs a single ended input to differential output conversion. This gain stage is followed by a continuous time low pass filter to limit the bandwidth. A 4<sup>th</sup> order sigma delta converter converts the analog signal to digital samples. A quadrature demodulation for f<sub>S</sub> and f<sub>M</sub> is than performed by an internal DSP, as well the handling of the bits and the frames.

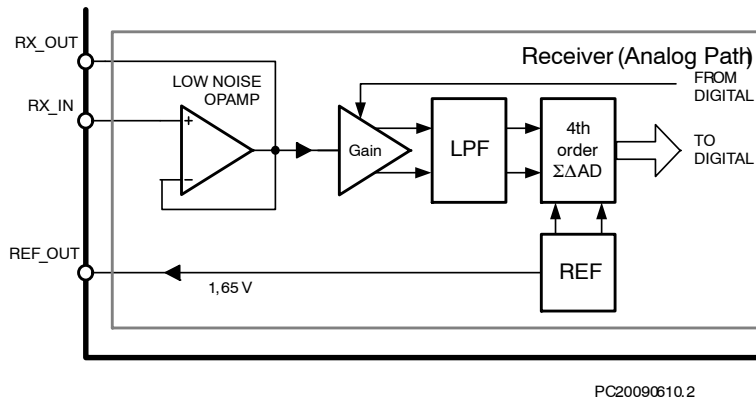

Figure 18. Analog Path of the Receiver

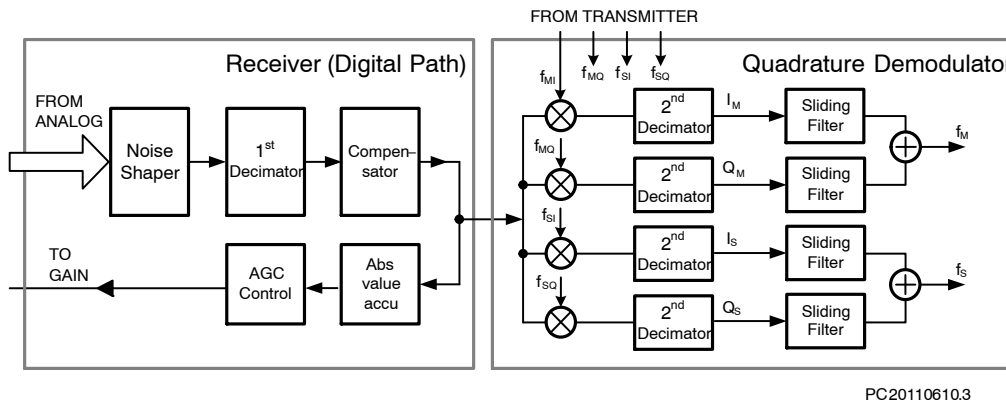

Figure 19. Digital Path of the Receiver ADC and Quadrature Demodulation

**50/60 Hz Suppression Filter**

NCN49597 receiver input provides a low noise input operational amplifier in a follower configuration which can be used to make a 50/60 Hz suppression filter with a minimum number of external components. Pin RX\_IN is the positive input and RX\_OUT is the output of the input low

noise operational amplifier. REF\_OUT is the analog output pin which provides the voltage reference (1.65 V) used by the A/D converter. This pin must be decoupled from the analog ground by a 1 μF ceramic capacitance (C<sub>DREF</sub>). It is not allowed to load this pin.

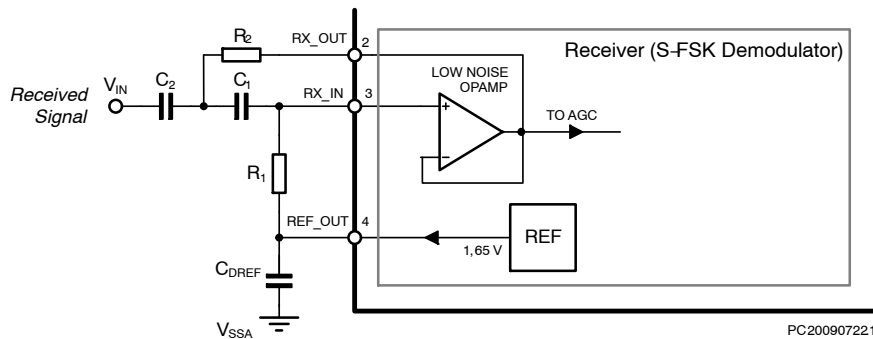

Figure 20. External Component Connection for 50/60 Hz Suppression Filter

RX\_IN is the positive analog input pin of the receiver low noise input op-amp. Together with the output RX\_OUT an active high pass filter is realized. This filter removes the main frequency (50 or 60 Hz) from the received signal. The filter characteristics are determined by external capacitors and resistors. Typical values are given in Table 27. For these

values and after this filter, a typical attenuation of 85 dB at 50 Hz is obtained. Figure 21 represents external components connection. In a typical application the coupling transformer in combination with a parallel capacitance forms a high pass filter with a typical attenuation of 60 dB. The combined effect of the two filters



decreases the voltage level of 230 Vrms at the mains frequency well below the sensitivity of the NCN49597.

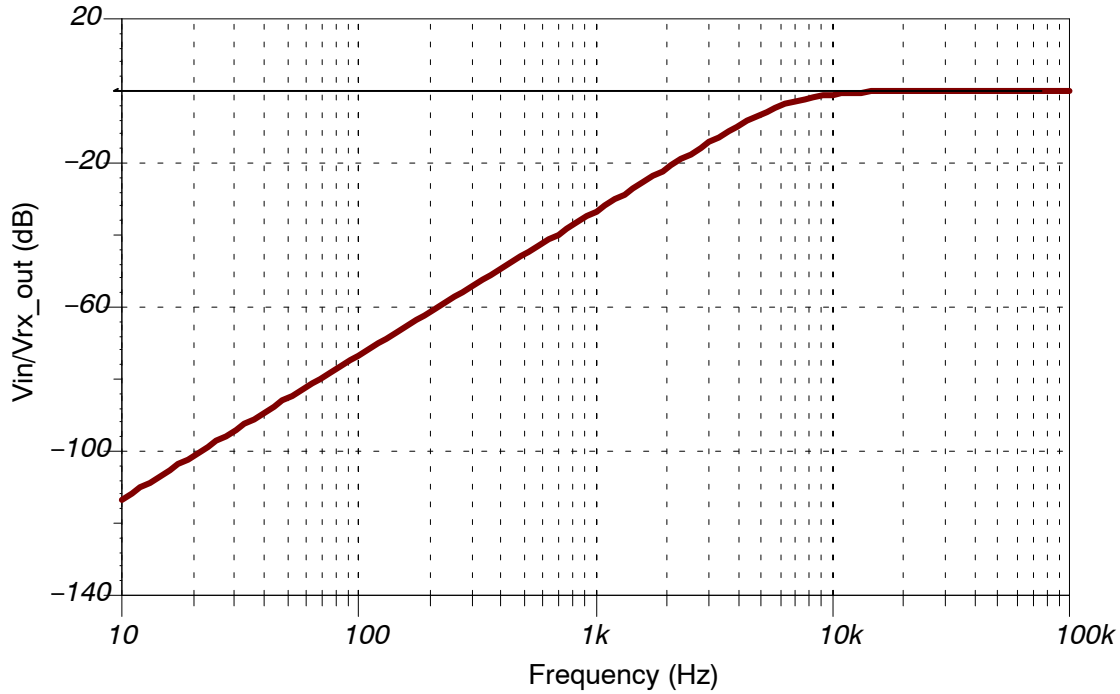

Figure 21. Transfer Function of 50 Hz Suppression Circuit

Table 22. VALUE OF THE RESISTORS AND CAPACITORS

Component	Value	Unit
C <sub>1</sub>	1.5	nF
C <sub>2</sub>	1.5	nF
C <sub>DREF</sub>	1	μF
R <sub>1</sub>	22	kΩ
R <sub>2</sub>	11	kΩ

Remark: The analog part of NCN49597 is referenced to the internal analog ground REF\_OUT = 1.65 V (typical value). If the external circuitry works with a different analogue reference level one must be sure to place a decoupling capacitor.

**Auto Gain Control (AGC)**

The receiver path has a gain stage which is used for automatic gain control. The gain can be changed in 8 steps of 6 dB. The control of the AGC is done by a digital circuit which measures the signal level after the AD converter, and regulates the average signal in a window around a percentage of the full scale. The AGC works in two cycles: a measurement cycle at the rising edge of the CHIP\_CLK and an update cycle starting at the next CHIP\_CLK.

**Low Noise Anti Aliasing Filter**

The receiver has a 3<sup>rd</sup> order continuous time low pass filter in the signal path. This filter is in fact the same block as in

the transmit path which can be shared because NCN49597 works in half duplex mode. The typical corner frequency  $f_{-3dB} = 138$  kHz and is internally trimmed to compensate for process variation.

**A/D Converter**

The output of the low pass filter is input for an analog 4<sup>th</sup> order sigma-delta converter. The DAC reference levels are supplied from the reference block. The digital output of the converter is fed into a noise shaping circuit blocking the quantization noise from the band of interest, followed by a decimation and a compensation step.

**Quadrature Demodulator**

The quadrature demodulation block takes the AD signal and mixes it with the in-phase and quadrature phase of the  $f_S$  and  $f_M$  carrier frequencies. After a low pass filter and rectification the mixer output signals are further processed in software. There the accumulation over a period of

CHIP\_CLK is done which results in the discrimination of data 0 and data 1.

**Bit Sync**

At the transmit side the data-stream is in sync and in phase with the zero crossing of the mains. The complex impedance

of the power line together with propagation delay in the zero cross detector and loop delay in the Rx-filter circuitry will cause a shift between the physical transmitted bit and the received S-FSK signal as illustrated in Figure 23.

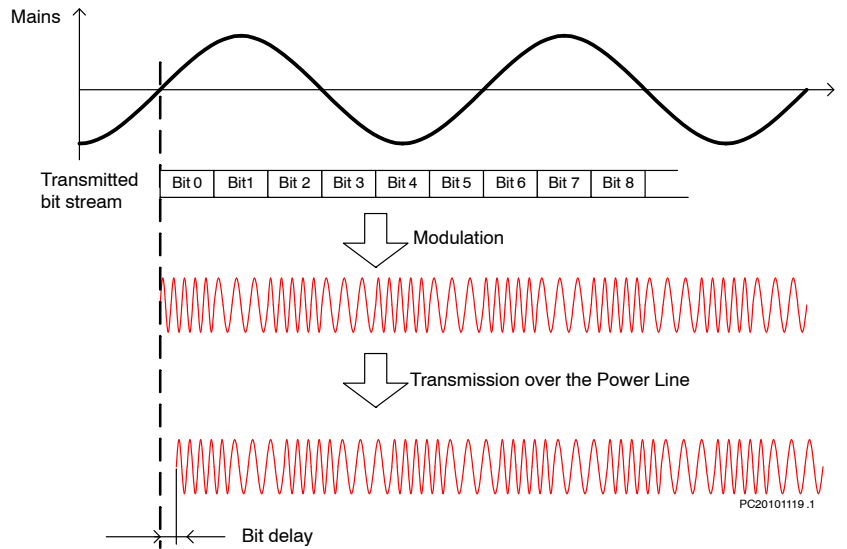

**Figure 22. Bit Delay Cause by Transmission Over a Power Line**

To compensate for this delay between physical and demodulated bit a synchro bit value is introduced. It shifts forward the Hardware Demodulating process up to seven chip clocks. See Figure 24.

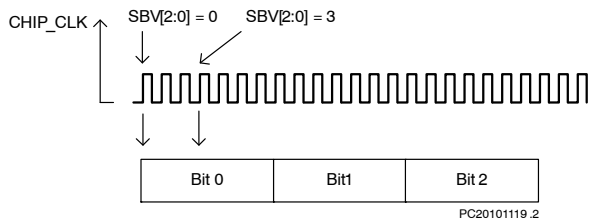

**Figure 23. Compensation for Bit Delay by Shifting Forward the Start of the Demodulating Process**

The synchro bit value can be set using register SBV [2:0].

**Table 23. SYNCHRO BIT VALUE**

SBV[2:0]	Bit Delay
000	0 CHIP_CLK
001	1 CHIP_CLK
010	2 CHIP_CLK
011	3 CHIP_CLK
100	4 CHIP_CLK
101	5 CHIP_CLK
110	6 CHIP_CLK
111	7 CHIP_CLK

**Communication Controller**

The Communication Controller block includes the ARM CORTEX M0 32 bit RISC processor, its peripherals: Data and Program RAM, Program ROM, TIMERS 1 and 2, Interrupt Control, SPI interface to an optional external flash memory, TEST-Control, Watchdog and Power On Reset (POR), I/O ports and the Serial Communication Interface (SCI). The micro-processor is programmed to handle the physical layer (chip synchronization), and the MAC layer conform to IEC 61334-5-1. The program is stored in a masked ROM. Depending on status of the SEN input, after power on reset NCN49597 will boot from internal ROM or external Flash. The RAM contains the necessary space to store the working data. The back-end interface is done through the Local Port and Serial Communication Interface block. This back-end is used for data transmission with the application micro controller (containing the application layer for concentrator, power meter, or other functions) and for the definition of the modem configuration.

More boot options and further details can be found in Reference 1.

The following section will give a brief overview of the functionality when boot from ROM. More details can be found in Reference 1.

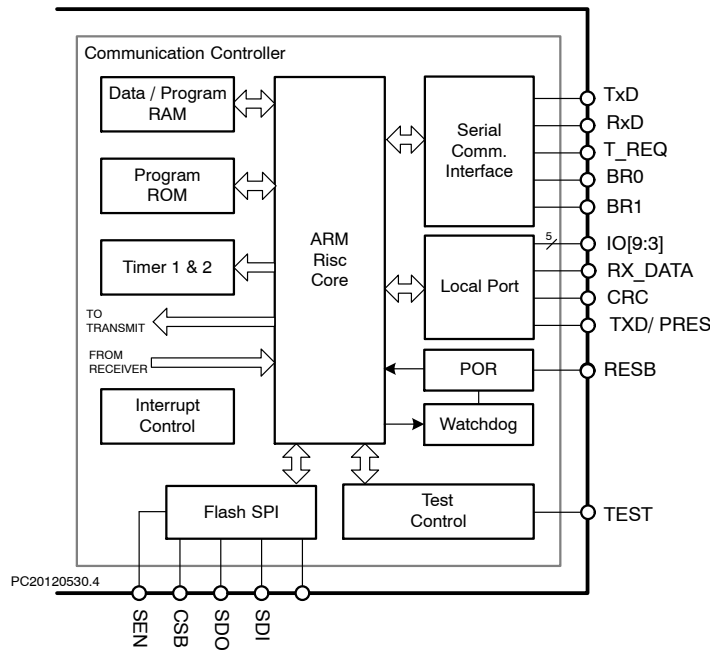

Figure 24. Communication Controller

**Local Port**

The controller uses three output ports to inform the actual status of the PLC communication. RX\_DATA indicates if NCN49597 is waiting for its configuration, if it is in research of synchronization, or if it is receiving data. CRC indicates if the received frames are valid: the cyclic redundancy code

(CRC) is correct. TXD/PRES is the output for either the transmitting data (TX\_DATA) or a synchronization signal with the time-slots (PRE\_SLOT).

When booting from ROM (SEN = VSS) IO[9:3] have no function. These IO's can be addressed when booting from the external Flash. See also Reference 1.

Table 24. OVERVIEW FUNCTIONALITY LOCAL PORT

Port	Function	Value	Explanation	Remark
RX_DATA	Data reception	10 Hz	Waiting for configuration	Output is oscillating
		0	After Synchro Confirm Time-out	
		1	Research of synchronization	
CRC	CRC OK	0		
		1	During the pause between 2 timeslots when a correct frame is received	
TXD/PRES	TX_DATA	0	Transmit of $f_S$	R_CONF[7] = 1
		1	Transmit of $f_M$	
	PRE_SLOT	0	See Figure 14	R_CONF[7] = 0
		1	See Figure 14	

**Serial Communication Interface (SCI)**

The Serial Communication Interface allows asynchronous communication. It can communicate with a UART = Universal Asynchronous Receiver Transmitter, ACIA = Asynchronous Communication Interface Adapter and all other chips that employ standard asynchronous serial communication. The serial communication interface has following characteristics:

- ◆ Half duplex.
- ◆ Standard NRZ format.
- ◆ Start bit, 8 data bits and 1 stop bit.
- ◆ Hardware programmable baud-rate via BR0 and BR1 pins (4800, 9600, 19200 and 38400 baud).
- ◆ 0–5 V levels with open drain for TxD.
- ◆ 0–5 V levels for RxD and T\_REQ.

# NCN49597

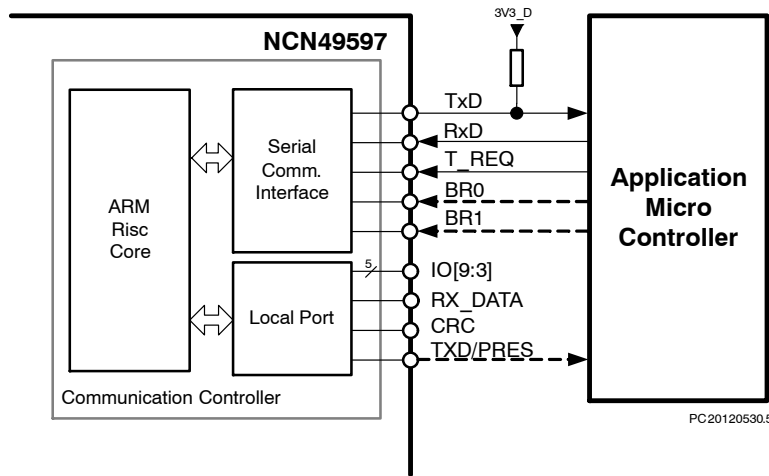

Figure 25. Connection to the Application Microcontroller

### Serial Communication Interface Physical Layer Description

The following pins control the serial communication interface.

- TXD:** Transmit data output. It is the data output of the NCN49597 and the input of the application micro controller.
- RXD:** Receive data input. It is the data input of the NCN49597 and the output of the application micro controller.
- T\_REQ:** Transmit Request input. Request for data transmission received

**BR0, BR1:** from the application micro controller Baud rate selection inputs. These pins are externally strapped to a value or controlled by the external application micro controller.

Table 25. BR1, BR0 BAUD RATES

BR1	BR0	SCI Baud Rate
0	0	4800
0	1	9600
1	0	19200
1	1	38400

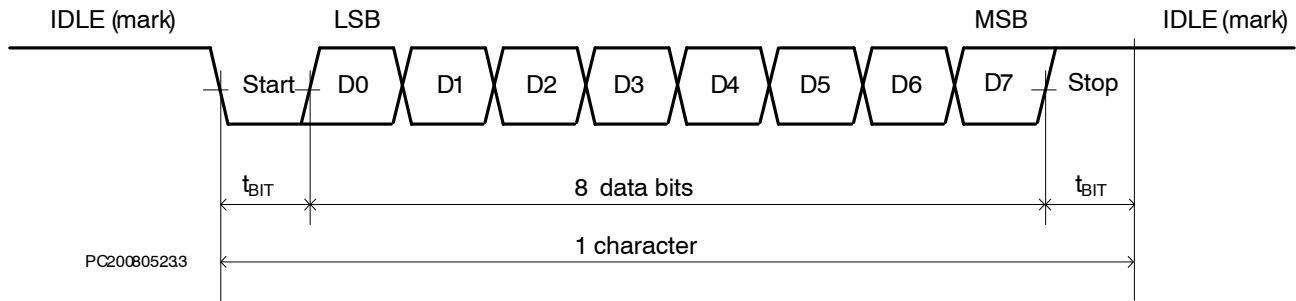

Figure 26. Data format

### Arbitration and Transfer

In order to avoid collisions between the data sent by the NCN49597 and the application micro controller, the NCN49597 is chosen as the transmitting controller. This means that when there is no local transfer, the NCN49597 can initiate a local communication without taking account of the application micro controller state. On the other hand, when the application micro controller wants to send data (using a local frame), it must first send a request for communication through the local input port named T\_REQ (Transmitting Request). Then the NCN49597 answers with a status message.

### Transfer from application micro controller to NCN49597

When the application micro controller wants to initiate a local transfer, it must pull down the T\_REQ signal. The NCN49597 answers within the  $t_{POLL}$  delay with the status message in which the application micro controller can read if the communication channel is available. If the communication is possible, the application micro controller can start to send its local frame within the  $t_{SR}$  delay. It should pull up the T\_REQ signal as soon as the first character (STX) has been sent. If the beginning of the local frame is not received before the  $t_{SR}$  delay was issued, the NCN49597

ignores the local frame. At the end of the data reception sent by the application micro controller on the RxD line, the NCN49597 sends a byte on the TxD line in order to inform about the status of the transmitting <ACK> (=0x06) or <NAK> (=0x15).

Remark: If the application micro controller only wants to know the state of the NCN49597, it has just to pull up the T\_REQ signal after the reception of the status message.

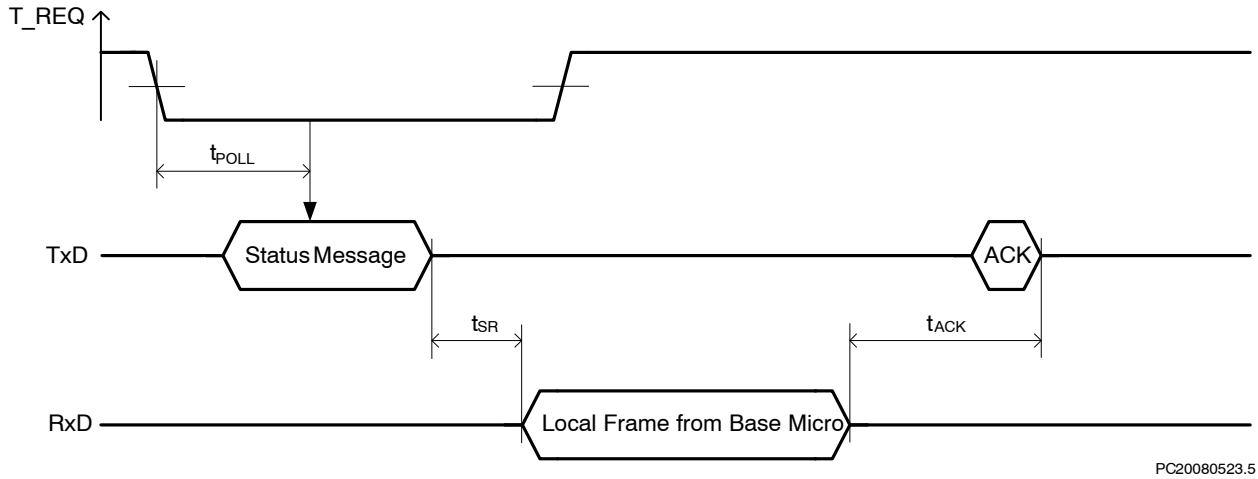

Figure 27. Transfer from Application Microcontroller to NCN49597

If the length and the checksum of the local frame are both correct, the NCN49597 acknowledges with an <ACK> character. In other cases, it answers with a <NAK> character. In case of <NAK> response, or no acknowledgement from NCN49597 in the  $t_{ACK}$  time-out, a complete sequence must be restarted to repeat the frame.

**Transfer from NCN49597 to application micro controller**

When the NCN49597 wants to send a frame, it can directly send it without any previous request.

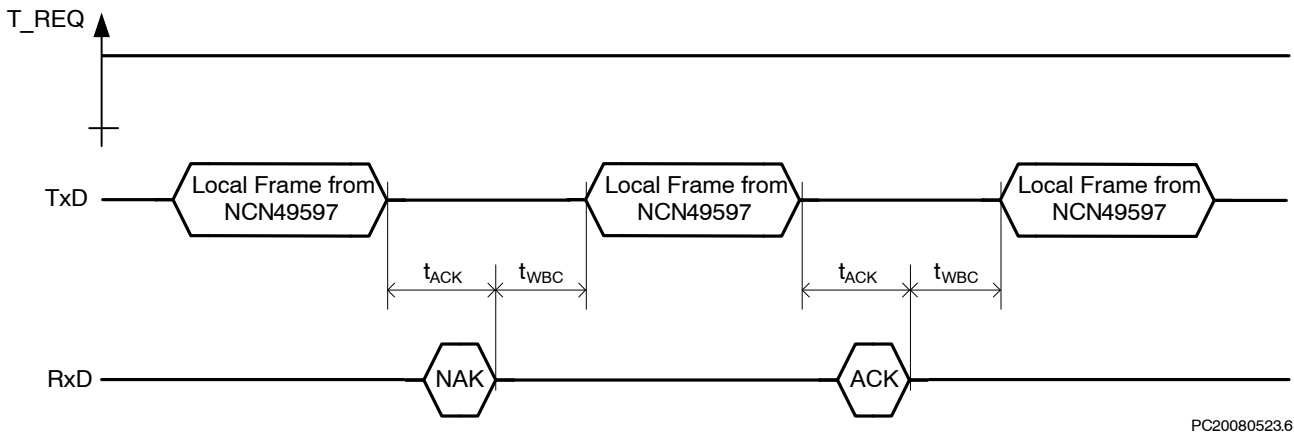

Figure 28. Transfer from NCN49597 to Application Micro Controller

If the length and the checksum of the local frame are both correct, the application micro controller acknowledges with an <ACK> character. In other cases, it answers with a <NAK> character. In case of <NAK> response from the Application micro controller, the NCN49597 will repeat the frame only once after a delay corresponding to  $t_{WBC}$  (Wait Before Continue). A non response from the application

micro controller or a framing error when an <ACK> character is awaited is considered as an acknowledgment.

**Character Time-out in Reception**

The time between two consecutive characters in a local frame should not exceed  $t_{IC}$  (Time-out Inter Character):

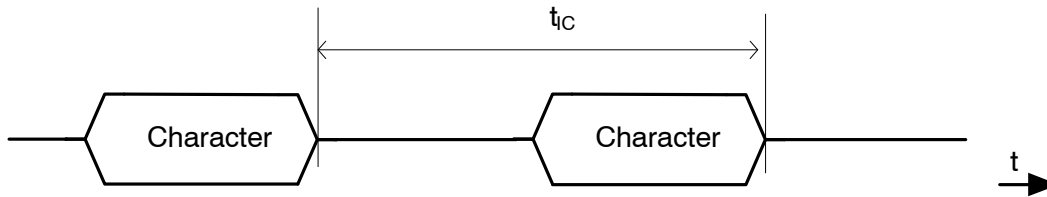

PC20080527

Figure 29. Character Time-out

After this delay, the frame reception is finished. If the length and the checksum are both correct, the local frame is taken in account otherwise all previous characters are discarded. The time out Inter Character ( $t_{IC}$ ) is set by default at 10 ms after a reset. The time out Inter character ( $t_{IC}$ ) is modified by the bit 7 of repeater parameter in the configuration frame. See Reference 1:

- bit 7 = 1 → the  $t_{IC}$  value is constant at 10 ms,
- bit 7 = 0 → the  $t_{IC}$  value represents 5 characters depending on the communication speed (defined by two local input ports BR0 and BR1).

Table 26. SERIAL COMMUNICATION TIME-OUT VALUES

Time-out	Meaning	Value		
Tpoll	Delay max. awaited by the base micro between the T_REQ pull down and the status message transmission (delay polling)	20 ms		
Tsr	Delay max. awaited by the NCN49597 between the end of the status transmitting and the reception of the STX character in the base micro frame (delay status/reception)	200 ms		
Tack	Delay max. awaited by either the NCN49597 or the base micro between the end of a transmitting and the reception of the ACK or NAK character sent by the other (delay ack).	40 ms		
Twbc	Delay max. awaited by either the NCN49597 or the base micro between the end of a reception and the transmission of the next frame (delay waiting before continue).	5 ms		
Tic	Delay max. awaited by either the NCN49597 or the base micro between two characters (delay inter characters) Programmable with the bit 7 of repeater parameter in the configuration frame	Bit 7 = 1	10 ms	
		Bit 7 = 0	4800 baud	10 ms
			9600 baud	5 ms
			19200 baud	2.5 ms
		38400 baud	1.25 ms	

**Watchdog**

The watchdog supervises the ARM and in case the firmware doesn't acknowledge at periodic times, a hard reset is generated.

**Configuration Registers**

A number of configuration registers can be accessed by the user by sending a WriteConfig\_Request over the SCI

interface. See also Reference 1. A brief overview of the accessible configuration registers is given below:

R\_CONFIG register configures the NCN49597 in the correct mode. The R\_CONFIG register is controlled by the embedded software and can be accessed via a WriteConfig\_Request.

Table 27. R\_CONF[9:0]

ARM Register	Hard Reset	Soft Reset	Description
R_CONF[7]	0	-	TXD/PRES_SEL
R_CONF[5:3]	000	-	MODE
R_CONF[2:1]	00	-	BAUDRATE
R_CONF[0]	0	-	MAINS_FREQ

Where:

TXD/PRES_SEL:	0:	TXD/PRES is PRE_SLOT output pin
	1:	TXD/PRES is TX_DATA output pin
MODE:	000 :	Initialisation
	001 :	Master Mode
	010 :	Slave Mode
	011 :	Reserved
	1xx :	Test Mode
BAUDRATE:	00:	6 data bits per mains period = 300 baud @ 50 Hz
	01:	12 data bits per mains period = 600 baud @ 50 Hz
	10:	24 data bits per mains period = 1200 baud @ 50 Hz
	11:	48 data bits per mains period = 2400 baud @ 50 Hz
MAINS_FREQ:	0:	50 Hz
	1:	60 Hz

R\_FS and R\_FM step registers are defining the space and mark frequency. Explanation on the values can be found in paragraph Sine wave generator. This register can be accessed via a WriteConfig\_Request.

Table 28. FS AND FM STEP REGISTERS

ARM Register	Hard Reset	Soft Reset	Description
R_FS[15:0]	0000h	0000h	Step register for the space frequency $f_S$
R_FM[15:0]	0000h	0000h	Step register for the mark frequency $f_M$

R\_ZC\_ADJUST register defines the value which is pre-loaded in the PLL counter. This is used to fine tune the phase difference between CHIP\_CLK and the – to + zero cross of the mains. Explanation on the values can be found in paragraph 50/60 Hz PLL.

Table 29. ZC\_ADJUST REGISTERS

ARM Register	Hard Reset	Soft Reset	Description
R_ZC_ADJUST[7:0]	02h	02h	Fine tuning of phase difference between CHIP_CLK and rising edge of Mains zero cross

R\_ALC\_CTRL register enables or disables the Automatic Level Control. In case ALC is disabled the attenuation of the TX output driver is fixed according to the value in R\_ALC\_CTRL[2:0]. Explanation on the attenuation values can be found in paragraph Amplifier with Automatic Level Control.

Table 30. ALC\_CTRL REGISTERS

ARM Register	Hard Reset	Soft Reset	Description
R_ALC_CTRL[3:0]	00h	00h	Control register for the automatic level control

Where:

R_ALC_CTRL[3]:	0:	Automatic level control is enabled
	1:	Automatic level control is disabled and attenuation is fixed
R_ALC_CTRL[2:0]:		Fixed attenuation value

**Table 31. FIXED TRANSMITTER OUTPUT ATTENUATION**

ALC_CTRL[2:0]	Attenuation
000	0 dB
001	-3 dB
010	-6 dB
011	-9 dB
100	-12 dB
101	-15 dB
110	-18 dB
111	-21 dB

**Reset and Low Power**

NCN49597 has two reset modes: hard reset and soft reset.

The hard reset initializes the complete IC (hardware and ARM) excluding the data RAM for the ARM. This makes sure that start-up of hardware and ARM is guaranteed. A hard reset is active when pin RESB = 0 or when the power supply  $V_{DD} < V_{POR}$  (See Table 14). When switching on the power supply the output of the crystal oscillator is disabled until a few 1000 clock pulses have been detected, this to enable the oscillator to start up.

The soft reset initializes part of the hardware. The soft reset is activated when going into initialization mode for the

duration of maximum 1 CHIP\_CLK. Initialization mode is entered by R\_CONF[5:3] = 000.

The concept of NCN49597 has a number of provisions to have low power consumption. When working in transmit mode the analogue receiver path and most of the digital receive parts are disabled. When working in receive mode the analog transmitter and most of the digital transmit parts, except for the sine generation, are disabled.

When the pin RESB = 0 the power consumption is minimal. Only a limited power is necessary to maintain the bias of a minimum number of analog functions and the oscillator cell.

**REFERENCE**

In this document references are made to:

- Design Manual NCN49597  
<http://www.onsemi.com>
- EN 50065-1: Signaling on low-voltage electrical installations in the frequency range 3 kHz to 148.5 kHz  
<http://connect.nen.nl/~Preview.aspx?artfile=425728&RNR=66840>
- ERDF-CPT-Linky-SPEC-FONC-CPL version V1.0 Linky PLC profile functional specification  
<http://www.erdfdistribution.fr/medias/Linky/ERDF-CPT-Linky-SPEC-FONC-CPL.pdf>
- DLMS UA 1000-2 Ed. 7.0 DLMS/COSEM Architecture and Protocols  
<http://www.dlms.com/documentation/dlmsuacolouredbookspasswordprotectedarea/index.html>
- IEC 61334-5-1 Lower layer S-FSK Profile.  
[http://webstore.iec.ch/preview/info\\_iec61334-5-1%7Bed2.0%7Db.pdf](http://webstore.iec.ch/preview/info_iec61334-5-1%7Bed2.0%7Db.pdf)
- IEC 61334-5-1 Lower layer S-FSK Profile.  
[http://webstore.iec.ch/preview/info\\_iec61334-5-1%7Bed2.0%7Db.pdf](http://webstore.iec.ch/preview/info_iec61334-5-1%7Bed2.0%7Db.pdf)

**Table 32. ORDERING INFORMATION**

Device	Temperature Range	Package	Shipping <sup>†</sup>
NCN49597C5972MNG	-40°C – 125°C	QFN-52 (Pb-Free)	Tube
NCN49597C5972MNRG	-40°C – 125°C	QFN-52 (Pb-Free)	Tape & Reel

<sup>†</sup>For information on tape and reel specifications, including part orientation and tape sizes, please refer to our Tape and Reel Packaging Specification Brochure, BRD8011/D.



# NCN49597

## PACKAGE DIMENSIONS

QFN52 8x8, 0.5P  
CASE 485M-01  
ISSUE C

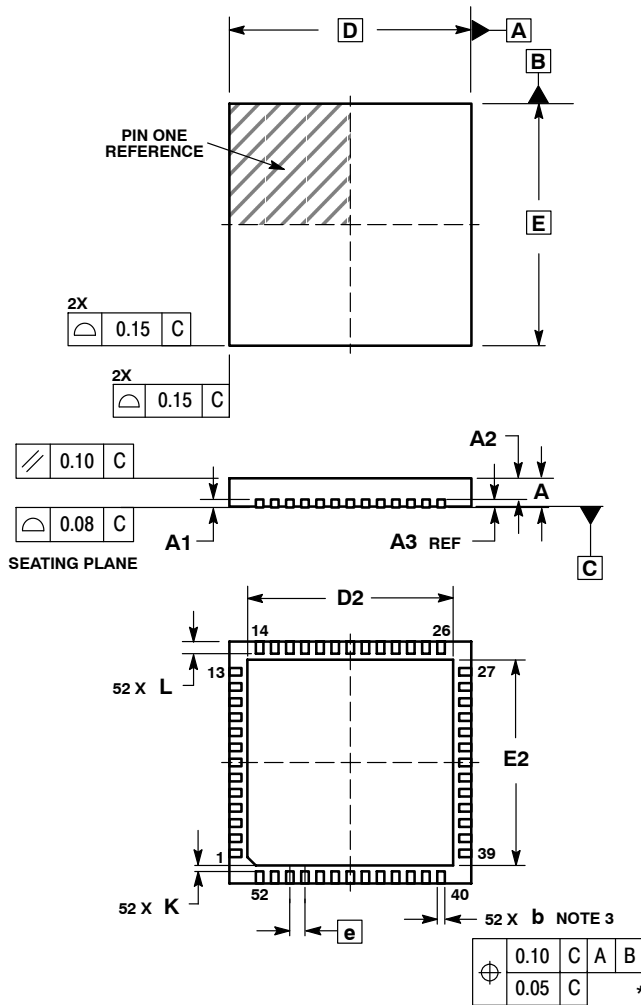

### NOTES:

1. DIMENSIONING AND TOLERANCING PER ASME Y14.5M, 1994.
2. CONTROLLING DIMENSION: MILLIMETERS
3. DIMENSION b APPLIES TO PLATED TERMINAL AND IS MEASURED BETWEEN 0.25 AND 0.30 MM FROM TERMINAL.
4. COPLANARITY APPLIES TO THE EXPOSED PAD AS WELL AS THE TERMINALS.

DIM	MILLIMETERS	
	MIN	MAX
A	0.80	1.00
A1	0.00	0.05
A2	0.60	0.80
A3	0.20	REF
b	0.18	0.30
D	8.00	BSC
D2	6.50	6.80
E	8.00	BSC
E2	6.50	6.80
e	0.50	BSC
K	0.20	---
L	0.30	0.50

### RECOMMENDED SOLDERING FOOTPRINT\*

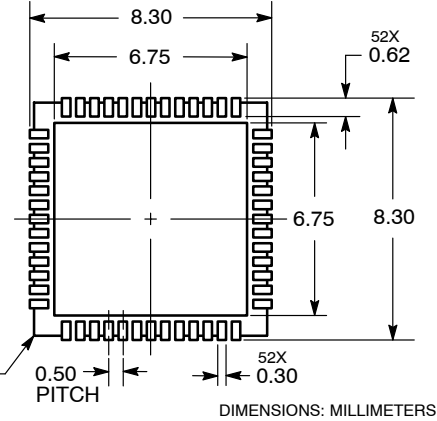

\*For additional information on our Pb-Free strategy and soldering details, please download the ON Semiconductor Soldering and Mounting Techniques Reference Manual, SOLDERRM/D.

ON Semiconductor and are registered trademarks of Semiconductor Components Industries, LLC (SCILLC). SCILLC owns the rights to a number of patents, trademarks, copyrights, trade secrets, and other intellectual property. A listing of SCILLC's product/patent coverage may be accessed at [www.onsemi.com/site/pdf/Patent-Marking.pdf](http://www.onsemi.com/site/pdf/Patent-Marking.pdf). SCILLC reserves the right to make changes without further notice to any products herein. SCILLC makes no warranty, representation or guarantee regarding the suitability of its products for any particular purpose, nor does SCILLC assume any liability arising out of the application or use of any product or circuit, and specifically disclaims any and all liability, including without limitation special, consequential or incidental damages. "Typical" parameters which may be provided in SCILLC data sheets and/or specifications can and do vary in different applications and actual performance may vary over time. All operating parameters, including "Typicals" must be validated for each customer application by customer's technical experts. SCILLC does not convey any license under its patent rights nor the rights of others. SCILLC products are not designed, intended, or authorized for use as components in systems intended for surgical implant into the body, or other applications intended to support or sustain life, or for any other application in which the failure of the SCILLC product could create a situation where personal injury or death may occur. Should Buyer purchase or use SCILLC products for any such unintended or unauthorized application, Buyer shall indemnify and hold SCILLC and its officers, employees, subsidiaries, affiliates, and distributors harmless against all claims, costs, damages, and expenses, and reasonable attorney fees arising out of, directly or indirectly, any claim of personal injury or death associated with such unintended or unauthorized use, even if such claim alleges that SCILLC was negligent regarding the design or manufacture of the part. SCILLC is an Equal Opportunity/Affirmative Action Employer. This literature is subject to all applicable copyright laws and is not for resale in any manner.

### PUBLICATION ORDERING INFORMATION

#### LITERATURE FULFILLMENT:

Literature Distribution Center for ON Semiconductor  
P.O. Box 5163, Denver, Colorado 80217 USA  
Phone: 303-675-2175 or 800-344-3860 Toll Free USA/Canada  
Fax: 303-675-2176 or 800-344-3867 Toll Free USA/Canada  
Email: [orderlit@onsemi.com](mailto:orderlit@onsemi.com)

N. American Technical Support: 800-282-9855 Toll Free  
USA/Canada  
Europe, Middle East and Africa Technical Support:  
Phone: 421 33 790 2910  
Japan Customer Focus Center  
Phone: 81-3-5817-1050

ON Semiconductor Website: [www.onsemi.com](http://www.onsemi.com)

Order Literature: <http://www.onsemi.com/orderlit>

For additional information, please contact your local Sales Representative

## Данный компонент на территории Российской Федерации

### Вы можете приобрести в компании MosChip.

Для оперативного оформления запроса Вам необходимо перейти по данной ссылке:

<http://moschip.ru/get-element>

Вы можете разместить у нас заказ для любого Вашего проекта, будь то серийное производство или разработка единичного прибора.

В нашем ассортименте представлены ведущие мировые производители активных и пассивных электронных компонентов.

Нашей специализацией является поставка электронной компонентной базы двойного назначения, продукции таких производителей как XILINX, Intel (ex.ALTERA), Vicor, Microchip, Texas Instruments, Analog Devices, Mini-Circuits, Amphenol, Glenair.

Сотрудничество с глобальными дистрибьюторами электронных компонентов, предоставляет возможность заказывать и получать с международных складов практически любой перечень компонентов в оптимальные для Вас сроки.

На всех этапах разработки и производства наши партнеры могут получить квалифицированную поддержку опытных инженеров.

Система менеджмента качества компании отвечает требованиям в соответствии с ГОСТ Р ИСО 9001, ГОСТ РВ 0015-002 и ЭС РД 009

### Офис по работе с юридическими лицами:

105318, г.Москва, ул.Щербаковская д.3, офис 1107, 1118, ДЦ «Щербаковский»

Телефон: +7 495 668-12-70 (многоканальный)

Факс: +7 495 668-12-70 (доб.304)

E-mail: [info@moschip.ru](mailto:info@moschip.ru)

Skype отдела продаж:

moschip.ru

moschip.ru\_4

moschip.ru\_6

moschip.ru\_9