

FEATURES

- I²C-compatible interface
- 3.4 MHz high speed I²C option
- 32-lead LFCSP_WQ (5 mm × 5 mm)
- Double-buffered input logic
 - Simultaneous update of multiple switches
- Up to 300 MHz bandwidth
- Fully specified at dual ±5 V/single +12 V operation
- On resistance 35 Ω maximum
- Low quiescent current < 20 μA
- Qualified for automotive applications

APPLICATIONS

- AV switching in TV
- Automotive infotainment
- AV receivers
- CCTV
- Ultrasound applications
- KVM switching
- Telecom applications
- Test equipment/instrumentation
- PBX systems

GENERAL DESCRIPTION

The **ADG2188** is an analog cross point switch with an array size of 8 × 8. The switch array is arranged so that there are eight columns by eight rows, for a total of 64 switch channels. The array is bidirectional, and the rows and columns can be configured as either inputs or outputs. Each of the 64 switches can be addressed and configured through the I²C-compatible interface. Standard, full speed, and high speed (3.4 MHz) I²C interfaces are supported. Any simultaneous switch combination is allowed. An additional feature of the **ADG2188** is that switches can be updated simultaneously, using the LDSW command. In addition, a RESET option allows all of the switch channels to be reset/off. At power on, all switches are in the off condition. The device is packaged in a 32-lead, 5 mm × 5 mm LFCSP_WQ.

FUNCTIONAL BLOCK DIAGRAM

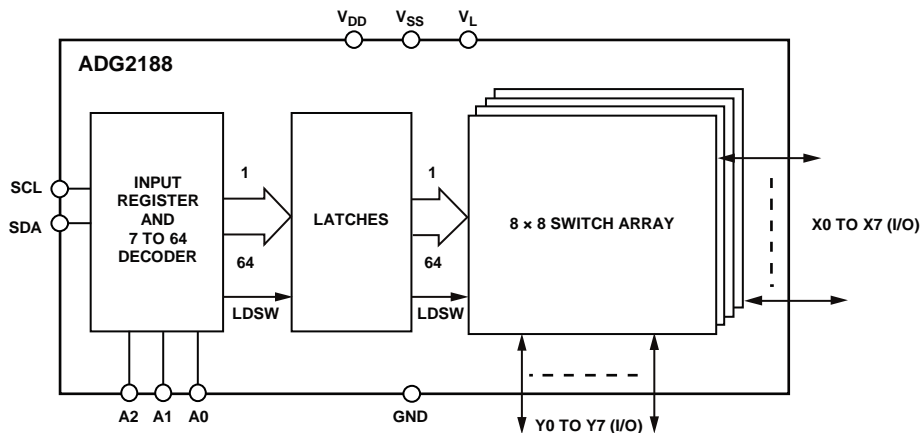

Figure 1.

Rev. B

Document Feedback

Information furnished by Analog Devices is believed to be accurate and reliable. However, no responsibility is assumed by Analog Devices for its use, nor for any infringements of patents or other rights of third parties that may result from its use. Specifications subject to change without notice. No license is granted by implication or otherwise under any patent or patent rights of Analog Devices. Trademarks and registered trademarks are the property of their respective owners.

One Technology Way, P.O. Box 9106, Norwood, MA 02062-9106, U.S.A.
 Tel: 781.329.4700 ©2006–2017 Analog Devices, Inc. All rights reserved.
 Technical Support www.analog.com

TABLE OF CONTENTS

Features	1	Readback	18
Applications.....	1	Serial Interface	19
General Description	1	High Speed I ² C Interface.....	19
Functional Block Diagram	1	Serial Bus Address.....	19
Revision History	2	Writing to the ADG2188.....	20
Specifications.....	3	Input Shift Register	20
I ² C Timing Specifications.....	7	Write Operation.....	22
Timing Diagram	8	Read Operation.....	22
Absolute Maximum Ratings.....	9	Evaluation Board	24
ESD Caution.....	9	Using the ADG2188 Evaluation Board	24
Pin Configuration and Function Descriptions.....	10	Power Supply.....	24
Typical Performance Characteristics	11	Schematics	25
Test Circuits.....	15	Outline Dimensions	27
Terminology	17	Ordering Guide	27
Theory of Operation	18	Automotive Products.....	27
RESET/Power-On Reset	18		
Load Switch (LDSW)	18		

REVISION HISTORY

7/2017—Rev. A to Rev. B

Changes to Figure 3.....	10
Changes to RESET/Power-On Reset Section.....	18
Updated Outline Dimensions	27
Changes to Ordering Guide	27

2/2015—Rev. 0 to Rev. A

Changed NC Pins to DNC Pins.....	10
Updated Outline Dimensions	27
Changes to Ordering Guide	27
Added Automotive Products Section.....	27

4/2006—Revision 0: Initial Version

SPECIFICATIONS

$V_{DD} = 12\text{ V} \pm 10\%$, $V_{SS} = 0\text{ V}$, $V_L = 5\text{ V}$, $GND = 0\text{ V}$, all specifications T_{MIN} to T_{MAX} , unless otherwise noted.¹

Table 1.

Parameter	B Version		Y Version		Unit	Test Conditions/Comments
	+25°C	-40°C to +85°C	+25°C	-40°C to +125°C		
ANALOG SWITCH						
Analog Signal Range		$V_{DD} - 2\text{ V}$		$V_{DD} - 2\text{ V}$	V max	
On Resistance, R_{ON}	30		30		Ω typ	$V_{DD} = 10.8\text{ V}$, $V_{IN} = 0\text{ V}$, $I_S = -10\text{ mA}$
	35	40	35	42	Ω max	
	32		32		Ω typ	$V_{DD} = 10.8\text{ V}$, $V_{IN} = 1.4\text{ V}$, $I_S = -10\text{ mA}$
	37	42	37	47	Ω max	
	45		45		Ω typ	$V_{DD} = 10.8\text{ V}$, $V_{IN} = 5.4\text{ V}$, $I_S = -10\text{ mA}$
	50	57	50	62	Ω max	
On Resistance Matching	4.5		4.5		Ω typ	$V_{DD} = 10.8\text{ V}$, $V_{IN} = 0\text{ V}$, $I_S = -10\text{ mA}$
Between Channels, ΔR_{ON}	8	9	8	10	Ω max	
On Resistance Flatness, $R_{FLAT(ON)}$	2.3		2.3		Ω typ	$V_{DD} = 10.8\text{ V}$, $V_{IN} = 0\text{ V to } 1.4\text{ V}$, $I_S = -10\text{ mA}$
	3.5	4	3.5	5	Ω max	
	14.5		14.5		Ω typ	$V_{DD} = 10.8\text{ V}$, $V_{IN} = 0\text{ V to } 5.4\text{ V}$, $I_S = -10\text{ mA}$
	18	20	18	22	Ω max	
LEAKAGE CURRENTS						
Channel Off Leakage, I_{OFF}	± 0.03		± 0.03		μA typ	$V_{DD} = 13.2\text{ V}$
Channel On Leakage, I_{ON}	± 0.03		± 0.03		μA typ	$V_X = 7\text{ V}/1\text{ V}$, $V_Y = 1\text{ V}/7\text{ V}$
						$V_X = V_Y = 1\text{ V}$ or 7 V
DYNAMIC CHARACTERISTICS²						
C_{OFF}	11		11		pF typ	
C_{ON}	18.5		18.5		pF typ	
t_{ON}	170		170		ns typ	$R_L = 300\ \Omega$, $C_L = 35\text{ pF}$
	185	190	185	195	ns max	
t_{OFF}	210		210		ns typ	$R_L = 300\ \Omega$, $C_L = 35\text{ pF}$
	250	255	250	260	ns max	
THD + N	0.04		0.04		% typ	$R_L = 10\text{ k}\Omega$, $f = 20\text{ Hz to } 20\text{ kHz}$, $V_S = 1\text{ V p-p}$
PSRR			90		dB typ	$f = 20\text{ kHz}$; without decoupling; see Figure 24
-3 dB Bandwidth	210		210		MHz typ	Individual inputs to outputs
	16.5		16.5		MHz typ	8 inputs to 1 output
Off Isolation	-69		-69		dB typ	$R_L = 75\ \Omega$, $C_L = 5\text{ pF}$, $f = 5\text{ MHz}$
Channel-to-Channel Crosstalk						$R_L = 75\ \Omega$, $C_L = 5\text{ pF}$, $f = 5\text{ MHz}$
Adjacent Channels	-63		-63		dB typ	
Nonadjacent Channels	-76		-76		dB typ	
Differential Gain	0.4		0.4		% typ	$R_L = 75\ \Omega$, $C_L = 5\text{ pF}$, $f = 5\text{ MHz}$
Differential Phase	0.6		0.6		$^\circ$ typ	$R_L = 75\ \Omega$, $C_L = 5\text{ pF}$, $f = 5\text{ MHz}$
Charge Injection	-3.5		-3.5		pC typ	$V_S = 4\text{ V}$, $R_S = 0\ \Omega$, $C_L = 1\text{ nF}$
LOGIC INPUTS (A_X, RESET)²						
Input High Voltage, V_{INH}		2.0		2.0	V min	
Input Low Voltage, V_{INL}		0.8		0.8	V max	
Input Leakage Current, I_{IN}	0.005		0.005		μA typ	
		± 1		± 1	μA max	
Input Capacitance, C_{IN}	7		7		pF typ	

Parameter	B Version		Y Version		Unit	Test Conditions/Comments
	+25°C	-40°C to +85°C	+25°C	-40°C to +125°C		
LOGIC INPUTS (SCL, SDA) ²						
Input High Voltage, V_{INH}		0.7 V_L		0.7 V_L	V min	$V_{IN} = 0\text{ V to }V_L$
		$V_L + 0.3$		$V_L + 0.3$	V max	
Input Low Voltage, V_{INL}		-0.3		-0.3	V min	
		0.3 V_L		0.3 V_L	V max	
Input Leakage Current, I_{IN}	0.005	± 1	0.005	± 1	$\mu\text{A typ}$ $\mu\text{A max}$	
Input Hysteresis		0.05 V_L		0.05 V_L	V min	
Input Capacitance, C_{IN}	7		7		pF typ	
LOGIC OUTPUT (SDA) ²						
Output Low Voltage, V_{OL}		0.4		0.4	V max	$I_{SINK} = 3\text{ mA}$
		0.6		0.6	V max	$I_{SINK} = 6\text{ mA}$
Floating State Leakage Current		± 1		± 1	$\mu\text{A max}$	
POWER REQUIREMENTS						
I_{DD}	0.05		0.05		$\mu\text{A typ}$	Digital inputs = 0 V or V_L
		1		1	$\mu\text{A max}$	
I_{SS}	0.05		0.05		$\mu\text{A typ}$	Digital inputs = 0 V or V_L
		1		1	$\mu\text{A max}$	
I_L						Digital inputs = 0 V or V_L
Interface Inactive	0.3		0.3		$\mu\text{A typ}$	
		2		2	$\mu\text{A max}$	
Interface Active: 400 kHz f_{SCL}	0.1		0.1		mA typ	
		0.2		0.2	mA max	
Interface Active: 3.4 MHz f_{SCL}	0.4		0.4		mA typ	-HS model only
		1.2		1.7	mA max	

¹ Temperature range is as follows: B version: -40°C to +85°C; Y version: -40°C to +125°C.

² Guaranteed by design, not subject to production test.

$V_{DD} = +5\text{ V} \pm 10\%$, $V_{SS} = -5\text{ V} \pm 10\%$, $V_L = 5\text{ V}$, $GND = 0\text{ V}$, all specifications T_{MIN} to T_{MAX} , unless otherwise noted.¹

Table 2.

Parameter	B Version		Y Version		Unit	Test Conditions/Comments
	+25°C	-40°C to +85°C	+25°C	-40°C to +125°C		
ANALOG SWITCH						
Analog Signal Range					$V_{DD} - 2\text{ V}$	V max
On Resistance, R_{ON}	34		34			Ω typ
	40	45	40	50		Ω max
	50		50			Ω typ
	55	65	55	70		Ω max
	66		66			Ω typ
	75	85	75	95		Ω max
On Resistance Matching	4.5		4.5			Ω typ
Between Channels, ΔR_{ON}	8	9	8	10		Ω max
On Resistance Flatness, $R_{FLAT(ON)}$	17		17			Ω typ
	20	23	20	25		Ω max
	34		34			Ω typ
	42	45	42	48		Ω max
LEAKAGE CURRENTS						
Channel Off Leakage, I_{OFF}	± 0.03		± 0.03			μA typ
Channel On Leakage, I_{ON}	± 0.03		± 0.03			μA typ
DYNAMIC CHARACTERISTICS²						
C_{OFF}	6		6			pF typ
C_{ON}	9.5		9.5			pF typ
t_{ON}	170		170			ns typ
	200	215	200	220		ns max
t_{OFF}	210		210			ns typ
	250	255	250	260		ns max
THD + N	0.04		0.04			% typ
PSRR			90			dB typ
-3 dB Bandwidth	300		300			MHz typ
	18		18			MHz typ
Off Isolation	-66		-64			dB typ
Channel-to-Channel Crosstalk						
Adjacent Channels	-62		-62			dB typ
Nonadjacent Channels	-79		-79			dB typ
Differential Gain	1.5		1.5			% typ
Differential Phase	1.8		1.8			° typ
Charge Injection	-3		-3			pC typ
LOGIC INPUTS (Ax, RESET)²						
Input High Voltage, V_{INH}		2.0		2.0		V min
Input Low Voltage, V_{INL}		0.8		0.8		V max
Input Leakage Current, I_{IN}	0.005		0.005			μA typ
		± 1		± 1		μA max
Input Capacitance, C_{IN}	7		7			pF typ
LOGIC INPUTS (SCL, SDA)²						
Input High Voltage, V_{INH}		$0.7V_L$		$0.7V_L$		V min
		$V_L + 0.3$		$V_L + 0.3$		V max
Input Low Voltage, V_{INL}		-0.3		-0.3		V min
		$0.3V_L$		$0.3V_L$		V max
Input Leakage Current, I_{IN}	0.005		0.005			μA typ
		± 1		± 1		μA max

Parameter	B Version		Y Version		Unit	Test Conditions/Comments
	+25°C	-40°C to +85°C	+25°C	-40°C to +125°C		
Input Hysteresis		0.05 V _L		0.05 V _L	V min	
Input Capacitance, C _{IN}	7		7		pF typ	
LOGIC OUTPUT (SDA) ²						
Output Low Voltage, V _{OL}		0.4		0.4	V max	I _{SINK} = 3 mA
Floating State Leakage Current		0.6		0.6	V max	I _{SINK} = 6 mA
		±1		±1	μA max	
POWER REQUIREMENTS						
I _{DD}	0.05		0.005		μA typ	Digital inputs = 0 V or V _L
		1		1	μA max	
I _{SS}	0.05		0.005		μA typ	Digital inputs = 0 V or V _L
		1		1	μA max	
I _L						Digital inputs = 0 V or V _L
Interface Inactive	0.3		0.3		μA typ	
		2		2	μA max	
Interface Active: 400 kHz f _{SCL}	0.1		0.1		mA typ	
		0.1		0.1	mA max	
Interface Active: 3.4 MHz f _{SCL}	0.4		0.4		mA typ	-HS model only
		0.3		0.3	mA max	

¹ Temperature range is as follows: B version: -40°C to +85°C; Y version: -40°C to +125°C.

² Guaranteed by design, not subject to production test.

I²C TIMING SPECIFICATIONS

$V_{DD} = 5\text{ V to }12\text{ V}$; $V_{SS} = -5\text{ V to }0\text{ V}$; $V_L = 5\text{ V}$; $GND = 0\text{ V}$; $T_A = T_{MIN}$ to T_{MAX} , unless otherwise noted (see Figure 2).

Table 3.

Parameter ¹	Test Conditions/Comments	ADG2188 Limit at T_{MIN} , T_{MAX}			Description
		Min	Max	Unit	
f_{SCL}	Standard mode		100	kHz	Serial clock frequency
	Fast mode		400	kHz	
	High speed mode ²		3.4	MHz	
	$C_B = 100\text{ pF maximum}$ $C_B = 400\text{ pF maximum}$		1.7	MHz	
t_1	Standard mode	4		μs	t_{HIGH} , SCL high time
	Fast mode	0.6		μs	
	High speed mode ²	60		ns	
	$C_B = 100\text{ pF maximum}$ $C_B = 400\text{ pF maximum}$	120		ns	
t_2	Standard mode	4.7		μs	t_{LOW} , SCL low time
	Fast mode	1.3		μs	
	High speed mode ²	160		ns	
	$C_B = 100\text{ pF maximum}$ $C_B = 400\text{ pF maximum}$	320		ns	
t_3	Standard mode	250		ns	$t_{SU,DAT}$, data setup time
	Fast mode	100		ns	
	High speed mode ²	10		ns	
t_4^3	Standard mode	0	3.45	μs	$t_{HD,DAT}$, data hold time
	Fast mode	0	0.9	μs	
	High speed mode ²	0	70	ns	
	$C_B = 100\text{ pF maximum}$	0	70	ns	
	$C_B = 400\text{ pF maximum}$	0	150	ns	
t_5	Standard mode	4.7		μs	$t_{SU,STA}$, setup time for a repeated start condition
	Fast mode	0.6		μs	
	High speed mode ²	160		ns	
t_6	Standard mode	4		μs	$t_{HD,STA}$, hold time for a (repeated) start condition
	Fast mode	0.6		μs	
	High speed mode ²	160		ns	
t_7	Standard mode	4.7		μs	t_{BUF} , bus free time between a stop and a start condition
	Fast mode	1.3		μs	
t_8	Standard mode	4		μs	$t_{SU,STO}$, setup time for a stop condition
	Fast mode	0.6		μs	
	High speed mode ²	160		ns	
t_9	Standard mode		1000	ns	t_{RDA} , rise time of SDA signal
	Fast mode	$20 + 0.1 C_B$	300	ns	
	High speed mode ²		80	ns	
	$C_B = 100\text{ pF maximum}$	10	80	ns	
	$C_B = 400\text{ pF maximum}$	20	160	ns	
t_{10}	Standard mode		300	ns	t_{FDA} , fall time of SDA signal
	Fast mode	$20 + 0.1 C_B$	300	ns	
	High speed mode ²		80	ns	
	$C_B = 100\text{ pF maximum}$	10	80	ns	
	$C_B = 400\text{ pF maximum}$	20	160	ns	

Parameter ¹	Test Conditions/Comments	ADG2188 Limit at T _{MIN} , T _{MAX}			Description
		Min	Max	Unit	
t ₁₁	Standard mode		1000	ns	t _{RCL} , rise time of SCL signal
	Fast mode	20 + 0.1 C _B	300	ns	
	High speed mode ²				
	C _B = 100 pF maximum	10	40	ns	
t _{11A}	Standard mode		1000	ns	t _{RCL1} , rise time of SCL signal after a repeated start condition and after an acknowledge bit
	Fast mode	20 + 0.1 C _B	300	ns	
	High speed mode ²				
	C _B = 400 pF maximum	20	160	ns	
t ₁₂	Standard mode		300	ns	t _{FCL} , fall time of SCL signal
	Fast mode	20 + 0.1 C _B	300	ns	
	High speed mode ²				
	C _B = 400 pF maximum	20	80	ns	
t _{SP}	Fast mode	0	50	ns	Pulse width of suppressed spike
	High speed mode ²	0	10	ns	

¹ Guaranteed by initial characterization. All values measured with input filtering enabled. C_B refers to capacitive load on the bus line; t_r and t_f are measured between 0.3 V_{DD} and 0.7 V_{DD}.

² High speed I²C is available only in -HS models

³ A device must provide a data hold time for SDA to bridge the undefined region of the SCL falling edge.

TIMING DIAGRAM

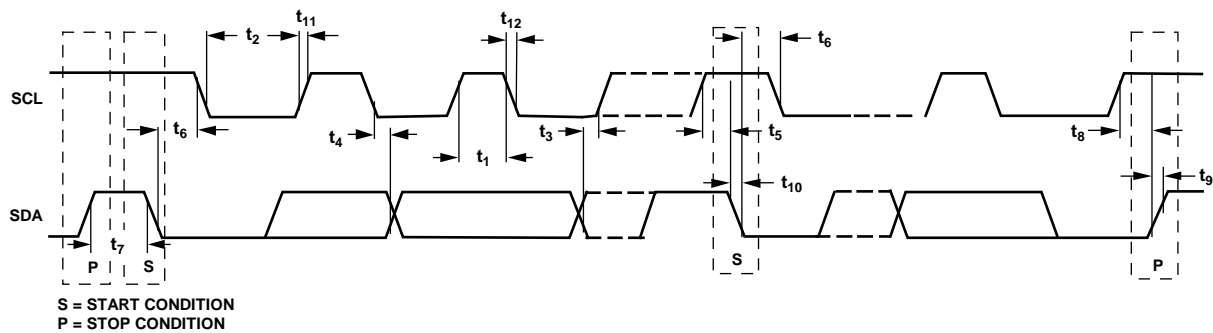

Figure 2. Timing Diagram for 2-Wire Serial Interface

058897-002

ABSOLUTE MAXIMUM RATINGS

$T_A = 25^\circ\text{C}$, unless otherwise noted.

Table 4.

Parameter	Rating
V_{DD} to V_{SS}	15 V
V_{DD} to GND	-0.3 V to +15 V
V_{SS} to GND	+0.3 V to -7 V
V_L to GND	-0.3 V to +7 V
Analog Inputs	$V_{SS} - 0.3\text{ V}$ to $V_{DD} + 0.3\text{ V}$
Digital Inputs	-0.3 V to $V_L + 0.3\text{ V}$ or 30 mA, whichever occurs first
Continuous Current	
10 V on Input; Single Input Connected to Single Output	65 mA
1 V on Input; Single Input Connected to Single Output	90 mA
10 V on Input; Eight Inputs Connected to Eight Outputs	25 mA
Operating Temperature Range	
Industrial (B Version)	-40°C to +85°C
Automotive (Y Version)	-40°C to +125°C
Storage Temperature Range	-65°C to +150°C
Junction Temperature	150°C
32-Lead LFCSP_WQ	
θ_{JA} Thermal Impedance	108.2°C/W
Reflow Soldering (Pb Free)	
Peak Temperature	260°C (+0/-5)
Time at Peak Temperature	10 sec to 40 sec

Stresses at or above those listed under Absolute Maximum Ratings may cause permanent damage to the product. This is a stress rating only; functional operation of the product at these or any other conditions above those indicated in the operational section of this specification is not implied. Operation beyond the maximum operating conditions for extended periods may affect product reliability.

ESD CAUTION



ESD (electrostatic discharge) sensitive device.

Charged devices and circuit boards can discharge without detection. Although this product features patented or proprietary protection circuitry, damage may occur on devices subjected to high energy ESD. Therefore, proper ESD precautions should be taken to avoid performance degradation or loss of functionality.

PIN CONFIGURATION AND FUNCTION DESCRIPTIONS

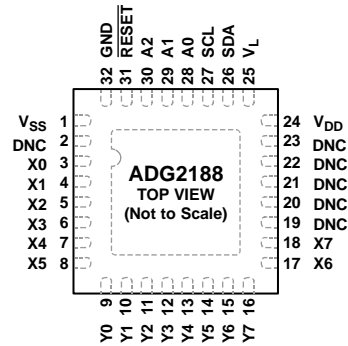

- NOTES
1. NC = NO CONNECT.
 2. THE EXPOSED PADDLE IS SOLDERED TO V_{SS} .

05897-003

Figure 3. Pin Configuration

Table 5. Pin Function Descriptions¹

Pin No.	Mnemonic	Description
1	V_{SS}	Negative Power Supply in a Dual-Supply Application. For single-supply applications, this pin must be tied to GND.
2, 19 to 23	DNC	Do No Connect.
3 to 8, 17, 18	X0 to X7	Can be inputs or outputs.
9 to 16	Y0 to Y7	Can be inputs or outputs.
24	V_{DD}	Positive Power Supply Input.
25	V_L	Logic Power Supply Input.
26	SDA	Digital I/O. Bidirectional open drain data line. External pull-up resistor required.
27	SCL	Digital Input, Serial Clock Line. Open drain input that is used in conjunction with SDA to clock data into the device. External pull-up resistor required.
28	A0	Logic Input. Address pin that sets the least significant bit of the 7-bit slave address.
29	A1	Logic Input. Address pin that sets the second least significant bit of the 7-bit slave address.
30	A2	Logic Input. Address pin that sets the third least significant bit of the 7-bit slave address.
31	$\overline{\text{RESET}}$	Active Low Logic Input. When this pin is low, all switches are open, and appropriate registers are cleared to 0.
32	GND	Ground. Reference point for all circuitry on the ADG2188 .
	EPAD	Exposed Paddle. The exposed paddle is soldered to V_{SS} .

¹ It is recommended that the exposed paddle be soldered to V_{SS} to improve heat dissipation and crosstalk.

TYPICAL PERFORMANCE CHARACTERISTICS

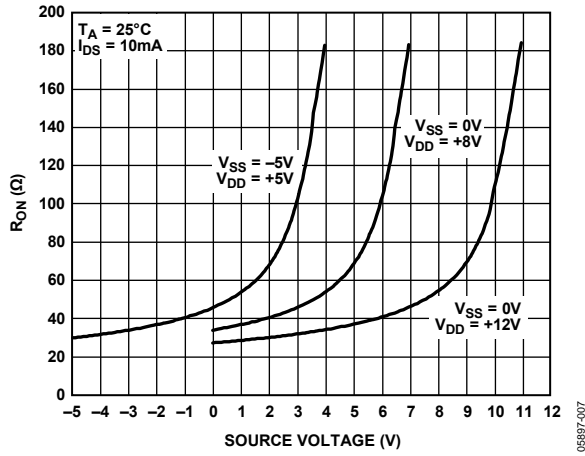

Figure 4. Signal Range

05897-007

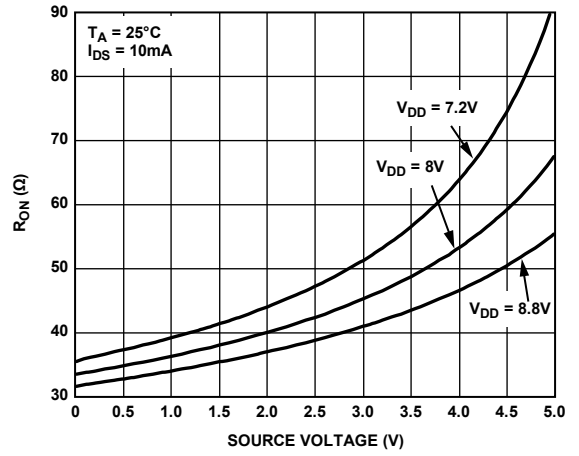

Figure 7. R_{ON} vs. Source Voltage, $V_{DD} = 8V \pm 10\%$

05897-025

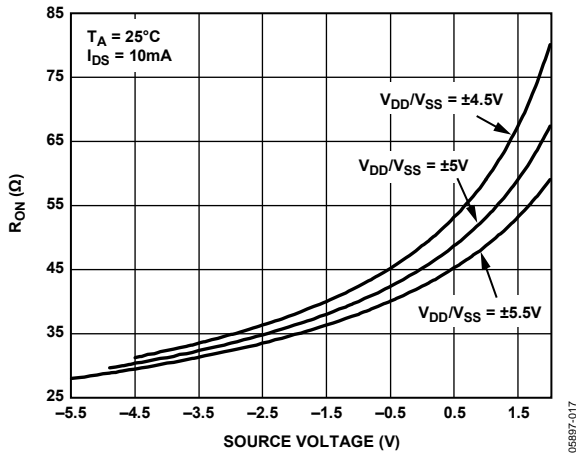

Figure 5. R_{ON} vs. Source Voltage, Dual $\pm 5V$ Supplies

05897-017

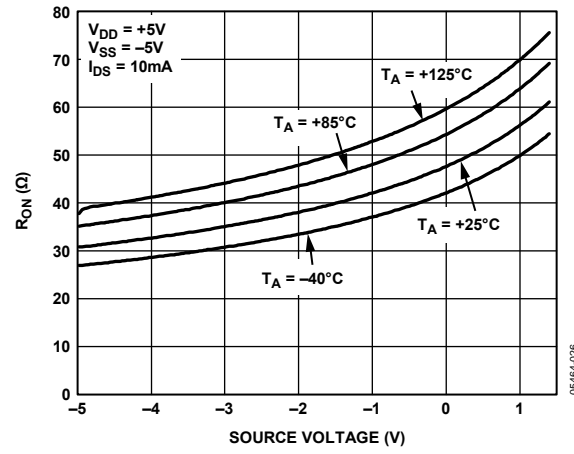

Figure 8. R_{ON} vs. Temperature, Dual $\pm 5V$ Supplies

05864-026

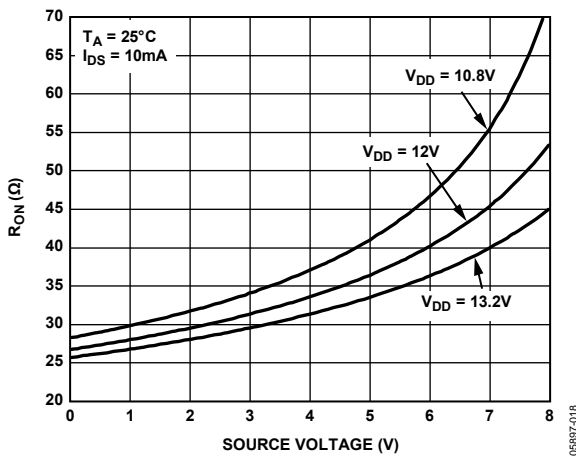

Figure 6. R_{ON} vs. Supplies, $V_{DD} = 12V \pm 10\%$

05897-018

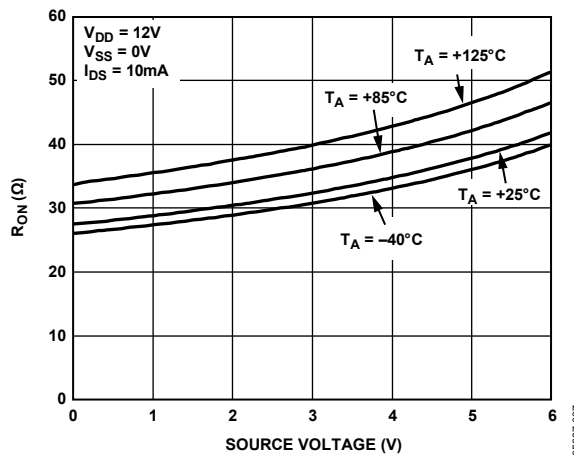

Figure 9. R_{ON} vs. Temperature, $V_{DD} = 12V$

05897-027

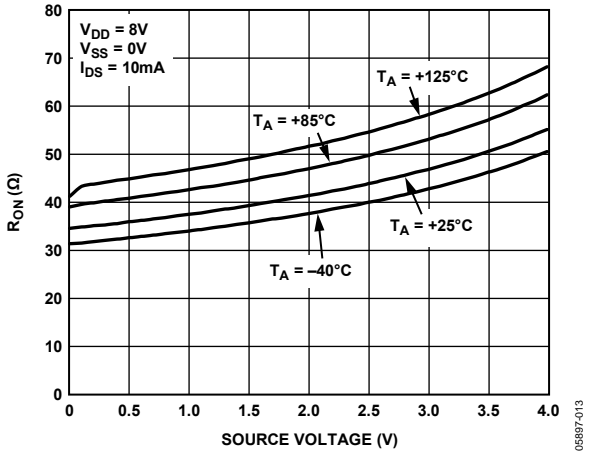

Figure 10. R_{ON} vs. Temperature, $V_{DD} = 8\text{ V}$

05897-013

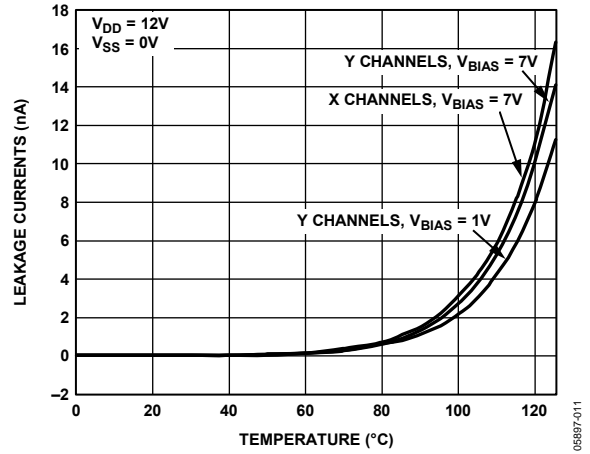

Figure 13. On Leakage vs. Temperature, 12 V Single Supply

05897-011

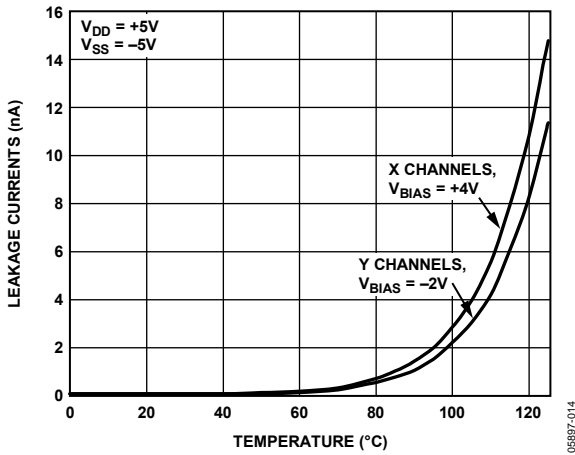

Figure 11. On Leakage vs. Temperature, Dual $\pm 5\text{ V}$ Supplies

05897-014

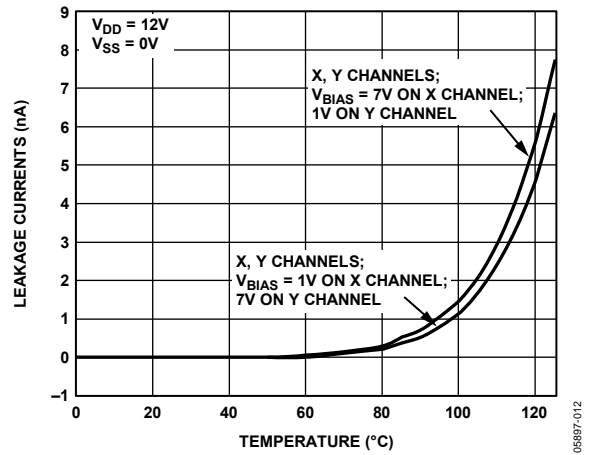

Figure 14. Off Leakage vs. Temperature, 12 V Single Supply

05897-012

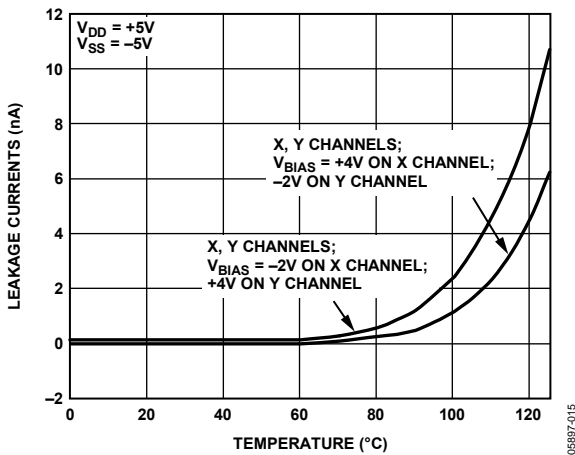

Figure 12. Off Leakage vs. Temperature, Dual $\pm 5\text{ V}$ Supplies

05897-015

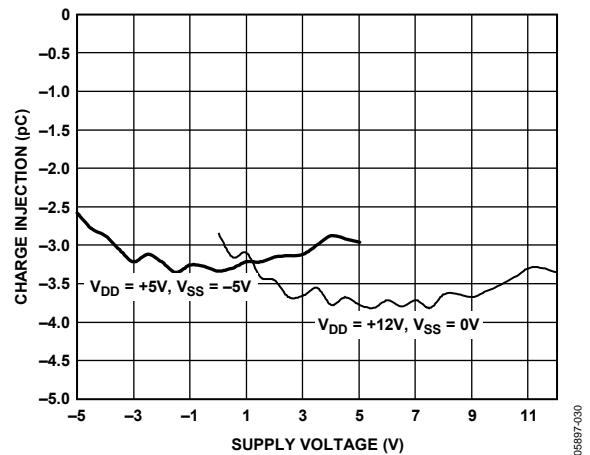

Figure 15. Charge Injection vs. Supply Voltage

05897-030

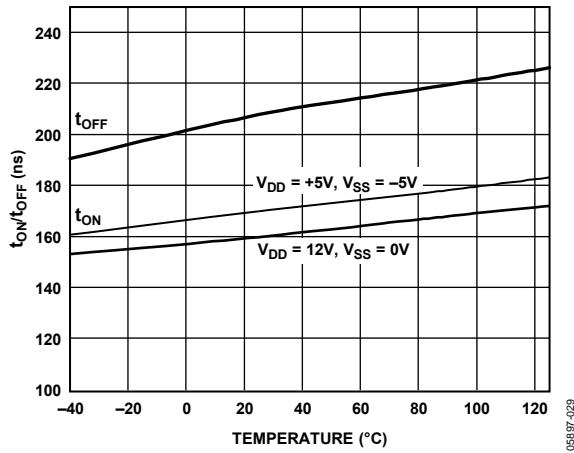

Figure 16. t_{ON}/t_{OFF} Times vs. Temperature

06897-029

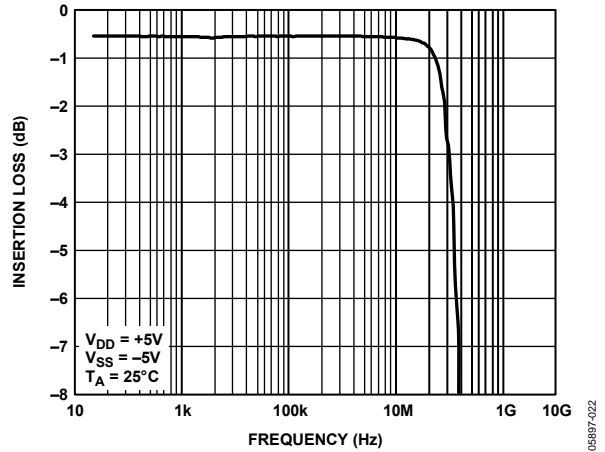

Figure 19. One Input to Eight Outputs Bandwidth, ± 5 V Dual Supply

06897-022

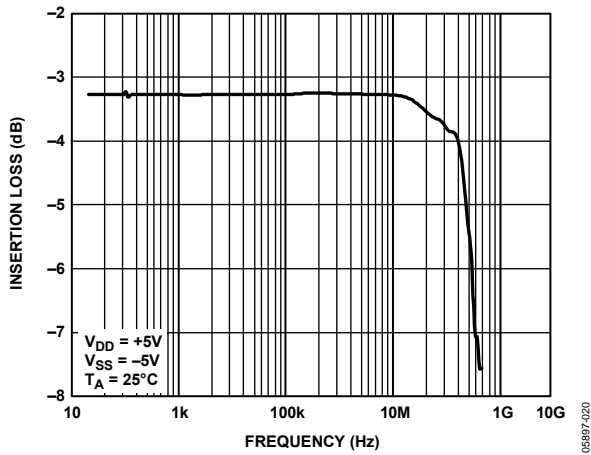

Figure 17. Individual Inputs to Individual Outputs Bandwidth, Dual ± 5 V Supply

06897-020

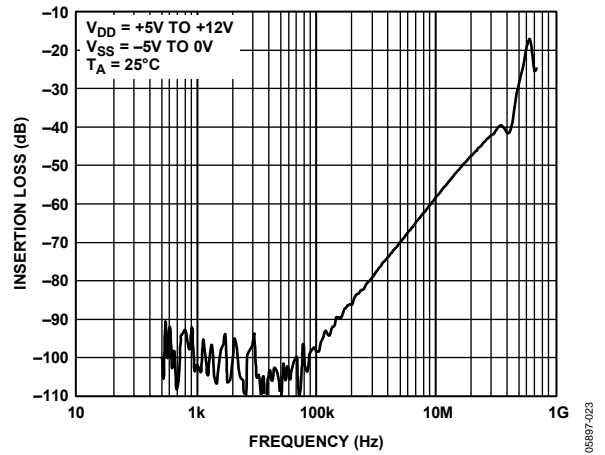

Figure 20. Off Isolation vs. Frequency

06897-023

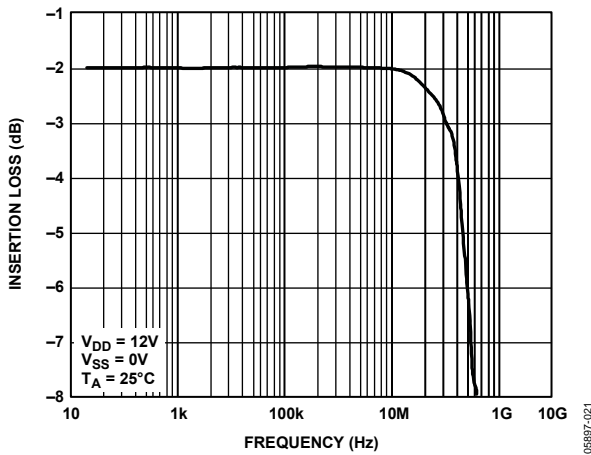

Figure 18. Individual Inputs to Individual Outputs Bandwidth, 12 V Single Supply

06897-021

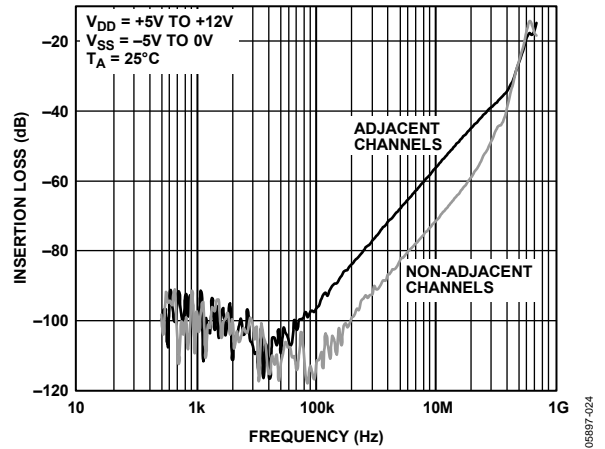

Figure 21. Crosstalk vs. Frequency

06897-024

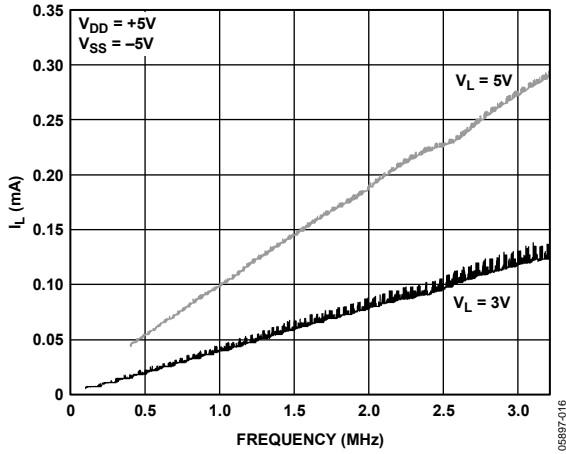

Figure 22. Digital Current (I_L) vs. Frequency

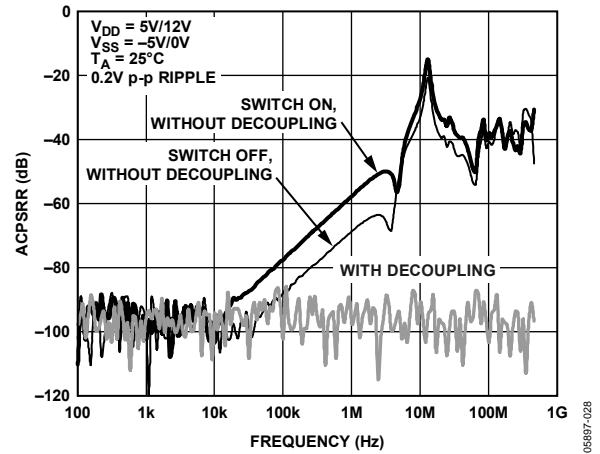

Figure 24. ACPSRR

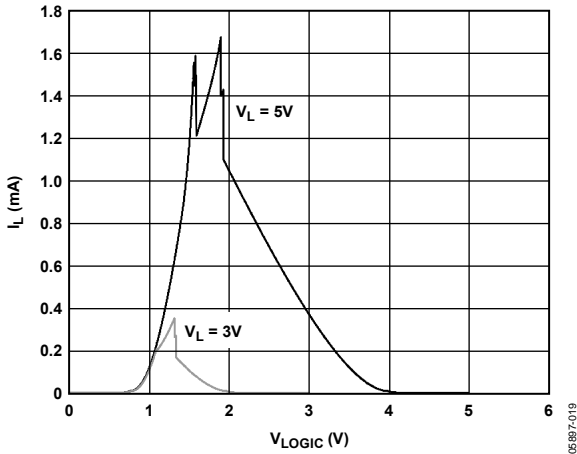

Figure 23. Digital Current (I_L) vs. V_{LOGIC} for Varying Digital Supply Voltage

TEST CIRCUITS

The test circuits show measurements on one channel for clarity, but the circuit applies to any of the switches in the matrix.

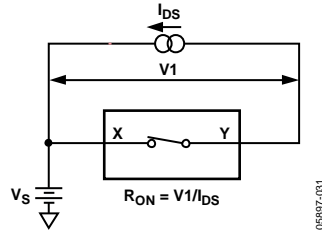

Figure 25. On Resistance

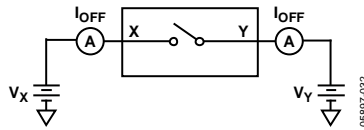

Figure 26. Off Leakage

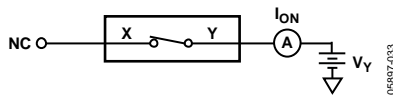

Figure 27. On Leakage

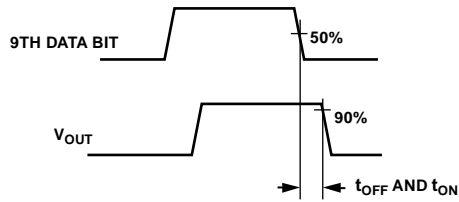
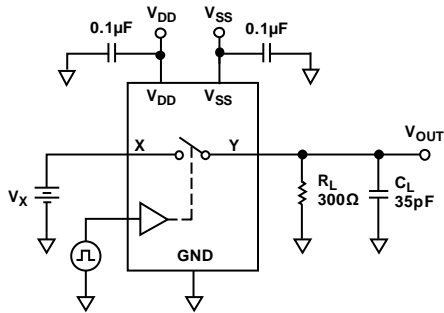

Figure 28. Switching Times, t_{ON} , t_{OFF}

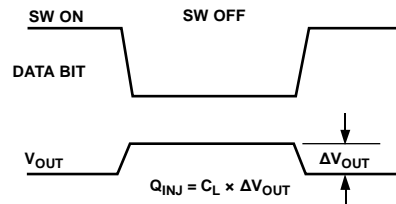
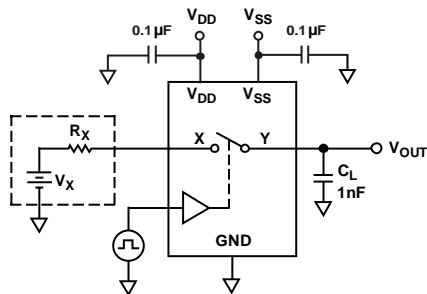
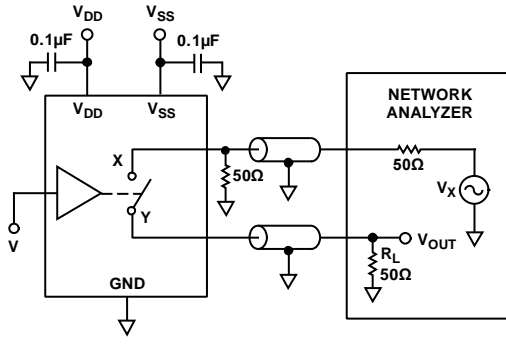

Figure 29. Charge Injection



$$\text{OFF ISOLATION} = 20 \log \frac{V_{\text{OUT}}}{V_{\text{S}}}$$

Figure 30. Off Isolation

05897-036

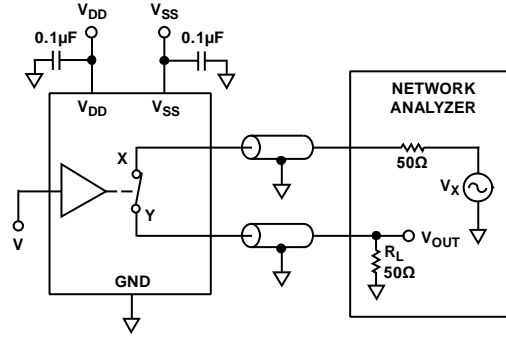

$$\text{INSERTION LOSS} = 20 \log \frac{V_{\text{OUT WITH SWITCH}}}{V_{\text{OUT WITHOUT SWITCH}}}$$

Figure 31. Bandwidth

05897-037

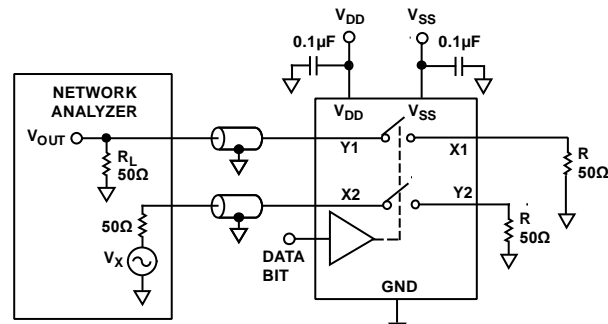

$$\text{CHANNEL-TO-CHANNEL CROSSTALK} = 20 \log \frac{V_{\text{OUT}}}{V_{\text{S}}}$$

Figure 32. Channel-to-Channel Crosstalk

05897-038

TERMINOLOGY

On Resistance (R_{ON})

The series on-channel resistance measured between the X input/output and the Y input/output.

On Resistance Match (ΔR_{ON})

The channel-to-channel matching of on resistance when channels are operated under identical conditions.

On Resistance Flatness ($R_{FLAT(ON)}$)

The variation of on resistance over the specified range produced by the specified analog input voltage change with a constant load current.

Channel Off Leakage (I_{OFF})

The sum of leakage currents into or out of an off channel input.

Channel On Leakage (I_{ON})

The current loss/gain through an on-channel resistance, creating a voltage offset across the device.

Input Leakage Current (I_{IN})

The current flowing into a digital input when a specified low level or high level voltage is applied to that input.

Input Off Capacitance (C_{OFF})

The capacitance between an analog input and ground when the switch channel is off.

Input/Output On Capacitance (C_{ON})

The capacitance between the inputs or outputs and ground when the switch channel is on.

Digital Input Capacitance (C_{IN})

The capacitance between a digital input and ground.

Output On Switching Time (t_{ON})

The time required for the switch channel to close. The time is measured from 50% of the logic input change to the time the output reaches 10% of the final value.

Output Off Switching Time (t_{OFF})

The time required for the switch to open. This time is measured from 50% of the logic input change to the time the output reaches 90% of the switch off condition.

Total Harmonic Distortion + Noise (THD + N)

The ratio of the harmonic amplitudes plus noise of a signal to the fundamental.

-3 dB Bandwidth

The frequency at which the output is attenuated by 3 dB.

Off Isolation

The measure of unwanted signal coupling through an off switch.

Crosstalk

The measure of unwanted signal that is coupled through from one channel to another as a result of parasitic capacitance.

Differential Gain

The measure of how much color saturation shift occurs when the luminance level changes. Both attenuation and amplification can occur; therefore, the largest amplitude change between any two levels is specified and is expressed as a percentage of the largest chrominance amplitude.

Differential Phase

The measure of how much hue shift occurs when the luminance level changes. It can be a negative or positive value and is expressed in degrees of subcarrier phase.

Charge Injection

The measure of the glitch impulse transferred from the digital input to the analog output during on/off switching.

Input High Voltage (V_{INH})

The minimum input voltage for Logic 1.

Input Low Voltage (V_{INL})

The maximum input voltage for Logic 0.

Output Low Voltage (V_{OL})

The minimum output voltage for Logic 1.

Input Low Voltage (V_{INL})

The maximum output voltage for Logic 0.

 I_{DD}

Positive supply current.

 I_{SS}

Negative supply current.

THEORY OF OPERATION

The [ADG2188](#) is an analog cross point switch with an array size of 8×8 . The eight rows are referred to as the X input/output lines, and the eight columns are referred to as the Y input/output lines. The device is fully flexible in that it connects any X line or number of X lines with any Y line when turned on. Similarly, it connects any X line with any number of Y lines when turned on.

Control of the [ADG2188](#) is carried out via an I²C interface. The device can be operated from single supplies of up to 13.2 V or from dual ± 5 V supplies. The [ADG2188](#) has many attractive features, such as the ability to reset all the switches, the ability to update many switches at the same time, and the option of reading back the status of any switch. All of these features are described in more detail here in the Theory of Operation section.

RESET/POWER-ON RESET

The [ADG2188](#) offers the ability to reset all of the 64 switches to the off state. This is done through the $\overline{\text{RESET}}$ pin. When the $\overline{\text{RESET}}$ pin is low, all switches are open (off), and appropriate registers are cleared. Note that the [ADG2188](#) also has a power-on reset block. This ensures that all switches are in the off condition at power-up of the device. In addition, all internal registers are filled with 0s and remain so until a valid write to the [ADG2188](#) takes place.

The digital section of the [ADG2188](#) goes through an initialization phase during the $\overline{\text{RESET}}$ power up. This initialization also occurs after a hardware or software reset. After reset, ensure that a minimum of 200 ns from the time of power-up or reset before any I²C command is issued.

Ensure that $\overline{\text{RESET}}$ does not drop out during the 200 ns initialization phase because it can result in an incorrect operation of the [ADG2188](#).

Ensure a minimum of 50 ns reset pulse width to achieve a complete reset.

LOAD SWITCH (LDSW)

LDSW is an active high command that allows a number of switches to be simultaneously updated. This is useful in applications where it is important to have synchronous transmission of signals. There are two LDSW modes: the transparent mode and the latched mode.

Transparent Mode

In this mode, the switch position changes after the new word is written into the input shift register. LDSW is set to 1.

Latched Mode

In this mode, the switch positions are not updated at the same time that the input registers are written to. This is achieved by setting LDSW to 0 for each word (apart from the last word) written to the device. Then, setting LDSW to 1 for the last word allows all of the switches in that sequence to be simultaneously updated.

READBACK

Readback of the switch array conditions is also offered when in standard mode and fast mode. Readback enables the user to check the status of the switches of the [ADG2188](#). This is very useful when debugging a system.

SERIAL INTERFACE

The ADG2188 is controlled via an I²C-compatible serial bus. The devices are connected to this bus as a slave device (no clock is generated by the switch).

HIGH SPEED I²C INTERFACE

In addition to standard and full speed I²C, the ADG2188 also supports the high speed (3.4 MHz) I²C interface. Only the -HS models provide this added performance. See the Ordering Guide for details.

SERIAL BUS ADDRESS

The ADG2188 has a 7-bit slave address. The four MSBs are hard coded to 1110, and the three LSBs are determined by the state of Pin A0, Pin A1, and Pin A2. By offering the facility to hardware configure Pin A0, Pin A1, and Pin A2, up to eight of these devices can be connected to a single serial bus.

The 2-wire serial bus protocol operates as follows:

1. The master initiates data transfer by establishing a start condition, defined as when a high-to-low transition on the SDA line occurs while SCL is high. This indicates that an address/data stream follows. All slave peripherals connected to the serial bus respond to the start condition and shift in the next eight bits, consisting of a 7-bit address (MSB first) plus an R/W bit that determines the direction of the data transfer, that is, whether data is written to or read from the slave device.
2. The peripheral whose address corresponds to the transmitted address responds by pulling the SDA line low during the ninth clock pulse, known as the acknowledge bit. At this stage, all other devices on the bus remain idle while the selected device waits for data to be written to or read from its serial register. If the R/W bit is 1 (high), the master reads from the slave device. If the R/W bit is 0 (low), the master writes to the slave device.
3. Data is transmitted over the serial bus in sequences of nine clock pulses: eight data bits followed by an acknowledge bit from the receiver of the data. Transitions on the SDA line must occur during the low period of the clock signal, SCL, and remain stable during the high period of SCL, because a low-to-high transition when the clock is high can be interpreted as a stop signal.
4. When all data bits have been read or written, a stop condition is established by the master. A stop condition is defined as a low-to-high transition on the SDA line while SCL is high. In write mode, the master pulls the SDA line high during the 10th clock pulse to establish a stop condition. In read mode, the master issues a no acknowledge for the ninth clock pulse (that is, the SDA line remains high). The master then brings the SDA line low before the 10th clock pulse and then high during the 10th clock pulse to establish a stop condition.

Refer to Figure 33 and Figure 34 for a graphical explanation of the serial data transfer protocol.

WRITING TO THE ADG2188

INPUT SHIFT REGISTER

The input shift register is 24 bits wide. A 3-byte write is necessary when writing to this register and is done under the control of the serial clock input, SCL. The contents of the three bytes of the input shift register are shown in Figure 33 and described in Table 6.

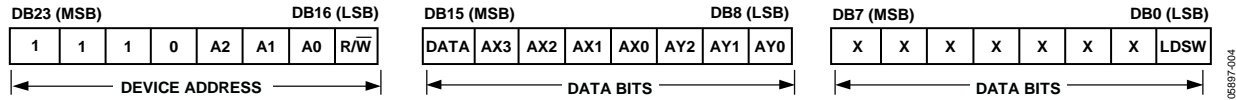

Figure 33. Data-Words

Table 6. Input Shift Register Bit Function Descriptions

Bit	Mnemonic	Description
DB23 to DB17	1110xxx	The MSBs of the ADG2188 are set to 1110. The LSBs of the address byte are set by the state of the three address pins, Pin A0, Pin A1, and Pin A2.
DB16	R/\overline{W}	Controls whether the ADG2188 slave device is read from or written to. If $R/\overline{W} = 1$, the ADG2188 is being read from. If $R/\overline{W} = 0$, the ADG2188 is being written to.
DB15	Data	Controls whether the switch is to be open (off) or closed (on). If Data = 0, the switch is open/off. If Data = 1, the switch is closed/on.
DB14 to DB11	AX3 to AX0	Controls I/Os X0 to X7. See Table 7 for the decode truth table.
DB10 to DB8	AY2 to AY0	Controls I/Os Y0 to Y7. See Table 7 for the decode truth table.
DB7 to DB1	X	Don't care.
DB0	LDSW	This bit is useful when a number of switches need to be updated simultaneously. If LDSW = 1, the switch position changes after the new word is read in. If LDSW = 0, the input data is latched, but the switch position is not changed.

As shown in Table 6, Bit DB11 to Bit DB14 control the X input/output lines, while Bit DB8 to Bit DB10 control the Y input/output lines. Table 7 shows the truth table for these bits. Note that the full coding sequence is written out for Channel Y0, and Channel Y1 to Channel Y7 follow a similar pattern. Note also that the RESET pin must be high when writing to the device.

Table 7. Address Decode Truth Table

DB15 DATA	DB14 AX3	DB13 AX2	DB12 AX1	DB11 AX0	DB10 AY2	DB9 AY1	DB8 AY0	Switch Configuration
1	0	0	0	0	0	0	0	X0 to Y0 (on)
0	0	0	0	0	0	0	0	X0 to Y0 (off)
1	0	0	0	1	0	0	0	X1 to Y0 (on)
0	0	0	0	1	0	0	0	X1 to Y0 (off)
1	0	0	1	0	0	0	0	X2 to Y0 (on)
0	0	0	1	0	0	0	0	X2 to Y0 (off)
1	0	0	1	1	0	0	0	X3 to Y0 (on)
0	0	0	1	1	0	0	0	X3 to Y0 (off)
1	0	1	0	0	0	0	0	X4 to Y0 (on)
0	0	1	0	0	0	0	0	X4 to Y0 (off)
1	0	1	0	1	0	0	0	X5 to Y0 (on)
0	0	1	0	1	0	0	0	X5 to Y0 (off)
X	0	1	1	0	0	0	0	Reserved
X	0	1	1	1	0	0	0	Reserved
1	1	0	0	0	0	0	0	X6 to Y0 (on)
0	1	0	0	0	0	0	0	X6 to Y0 (off)
1	1	0	0	1	0	0	0	X7 to Y0 (on)
0	1	0	0	1	0	0	0	X7 to Y0 (off)
X	1	0	1	0	0	0	0	Reserved

DB15 DATA	DB14 AX3	DB13 AX2	DB12 AX1	DB11 AX0	DB10 AY2	DB9 AY1	DB8 AY0	Switch Configuration
X	1	0	1	1	0	0	0	Reserved
X	1	1	0	0	0	0	0	Reserved
X	1	1	0	1	0	0	0	Reserved
X	1	1	1	0	0	0	0	Reserved
X	1	1	1	1	0	0	0	Reserved
1	0	0	0	0	0	0	1	X0 to Y1 (on)
0	0	0	0	0	0	0	1	X0 to Y1 (off)
..	
1	1	0	0	1	0	0	1	X7 to Y1 (on)
1	0	0	0	0	0	1	0	X0 to Y2 (on)
0	0	0	0	0	0	1	0	X0 to Y2 (off)
..	
1	1	0	0	1	0	1	0	X7 to Y2 (on)
1	0	0	0	0	0	1	1	X0 to Y3 (on)
0	0	0	0	0	0	1	1	X0 to Y3 (off)
..	
1	1	0	0	1	0	1	1	X7 to Y3 (on)
1	0	0	0	0	1	0	0	X0 to Y4 (on)
0	0	0	0	0	1	0	0	X0 to Y4 (off)
..	
1	1	0	0	1	1	0	0	X7 to Y4 (on)
1	0	0	0	0	1	0	1	X0 to Y5 (on)
0	0	0	0	0	1	0	1	X0 to Y5 (off)
..	
1	1	0	0	1	1	0	1	X7 to Y5 (on)
1	0	0	0	0	1	1	0	X0 to Y6 (on)
0	0	0	0	0	1	1	0	X0 to Y6 (off)
..	
1	1	0	0	1	1	1	0	X7 to Y6 (on)
1	0	0	0	0	1	1	1	X0 to Y7 (on)
0	0	0	0	0	1	1	1	X0 to Y7 (off)
..	
1	1	0	0	1	1	1	1	X7 to Y7 (on)

WRITE OPERATION

When writing to the [ADG2188](#), the user must begin with an address byte and R/W bit, after which the switch acknowledges that it is prepared to receive data by pulling SDA low. This address byte is followed by the two 8-bit words. The write operations for the switch array are shown in Figure 34. Note that it is only the condition of the switch corresponding to the bits in the data bytes that changes state. All other switches retain their previous condition.

READ OPERATION

Readback on the [ADG2188](#) is designed to work as a tool for debug and can output the status of any of the 64 switches of the device. The readback function is a two-step sequence that works as follows:

1. Select the relevant X line to be read back from. Note that there are eight switches connecting that X line to the eight Y lines. The next step involves writing to the [ADG2188](#) to tell the device to reveal the status of those eight switches.
 - a. Enter the I²C address of the [ADG2188](#), and set the R/W to 0 to indicate a write to the device.

- b. Enter the readback address for the X line of interest, the addresses of which are shown in Table 8. Note that the [ADG2188](#) is expecting a 2-byte write; therefore, be sure to also enter another byte of don't cares (see Figure 35).
 - c. The [ADG2188](#) then places the status of those eight switches in a register than can be read back.
2. The second step involves reading back from the register that holds the status of the eight switches associated with the X line of choice.
 - a. As before, enter the I²C address of the [ADG2188](#). This time, set the R/W to 1 to indicate a read back from the device.
 - d. As with a write to the device, the [ADG2188](#) outputs a 2-byte sequence during readback. Therefore, the first eight bits of data out that are read back are all 0s. The next eight bits of data that come back are the status of the eight Y lines attached to that particular X line. If the bit is a 1, then the switch is closed (on); similarly, if the bit is a 0, the switch is open (off).

The entire read sequence is shown in Figure 35.

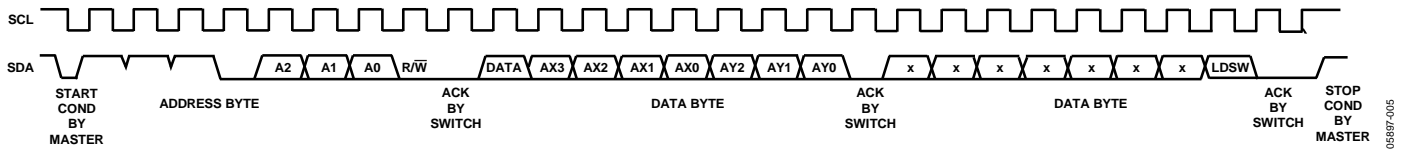

Figure 34. Write Operation

Table 8. Readback Addresses for Each X Line

X Line	RB7	RB6	RB5	RB4	RB3	RB2	RB1	RB0
X0	0	0	1	1	0	1	0	0
X1	0	0	1	1	1	1	0	0
X2	0	1	1	1	0	1	0	0
X3	0	1	1	1	1	1	0	0
X4	0	0	1	1	0	1	0	1
X5	0	0	1	1	1	1	0	1
X6	0	1	1	1	0	1	0	1
X7	0	1	1	1	1	1	0	1

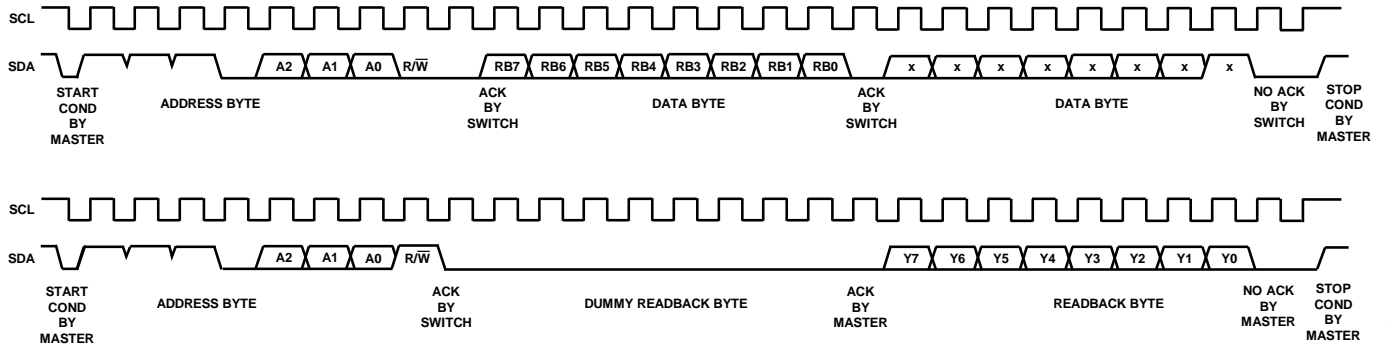

Figure 35. Read Operation

05897-006

EVALUATION BOARD

The [ADG2188](#) evaluation board allows designers to evaluate the high performance 8×8 switch array of the [ADG2188](#) with a minimum of effort.

The evaluation kit includes a populated, tested [ADG2188](#) printed circuit board. The evaluation board interfaces to the USB port of a PC, or it can be used as a standalone evaluation board. Software is available with the evaluation board that allows the user to easily program the [ADG2188](#) through the USB port. Schematics of the evaluation board are shown in Figure 36 and Figure 37. The software runs on any PC that has Microsoft® Windows® 2000 or Windows XP installed.

USING THE [ADG2188](#) EVALUATION BOARD

The [ADG2188](#) evaluation kit is a test system designed to simplify the evaluation of the [ADG2188](#). Each input/output of the device comes with a socket specifically chosen for easy audio/video evaluation. An application note is also available with the evaluation board that gives full information on operating the evaluation board.

POWER SUPPLY

The [ADG2188](#) evaluation board can be operated with both single and dual supplies. V_{DD} and V_{SS} are supplied externally by the user. The V_I supply can be applied externally, or the USB port can power the digital circuitry.

SCHEMATICS

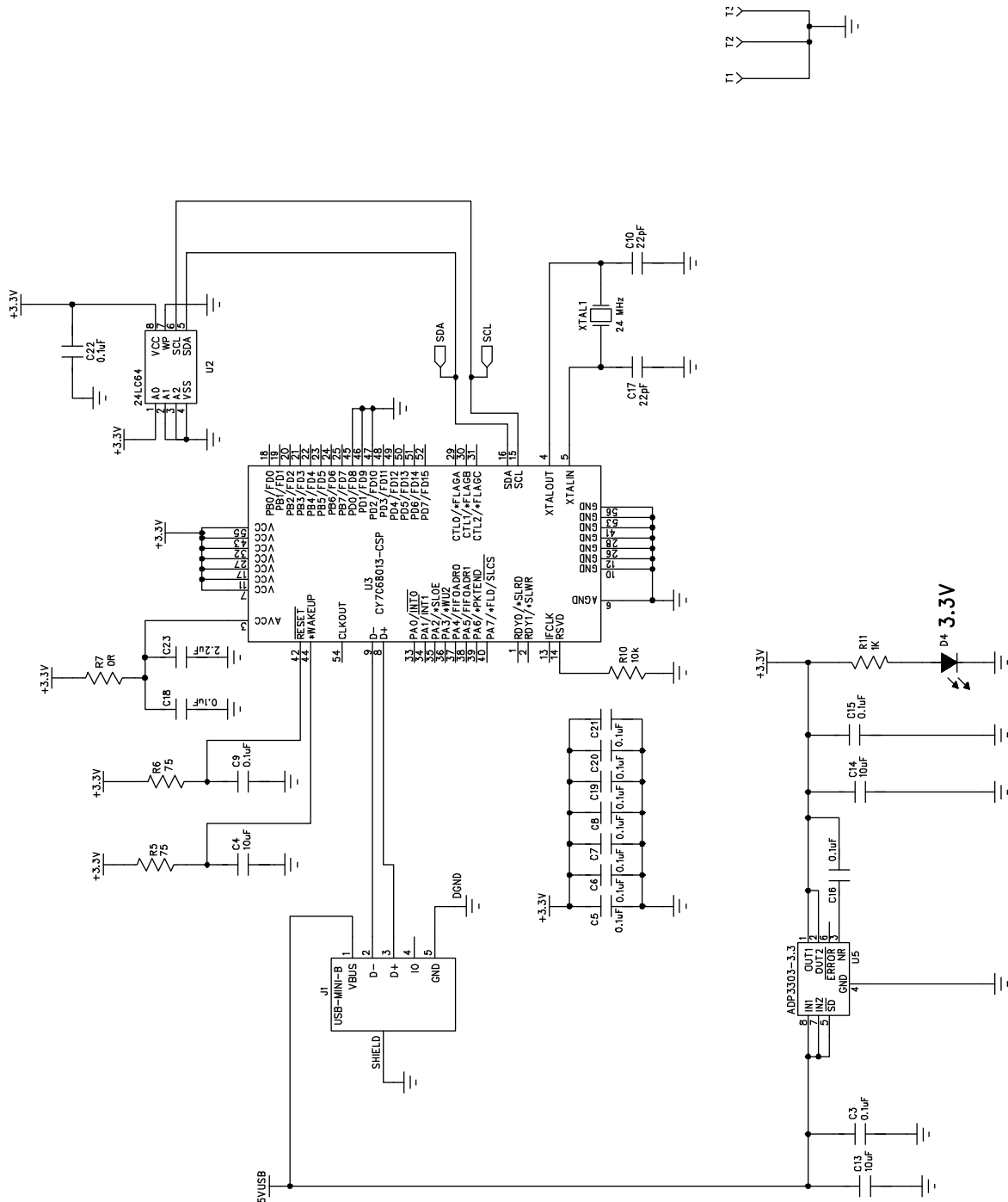

Figure 36. EVAL-ADG2188EB Schematic, USB Controller Section

05887-041

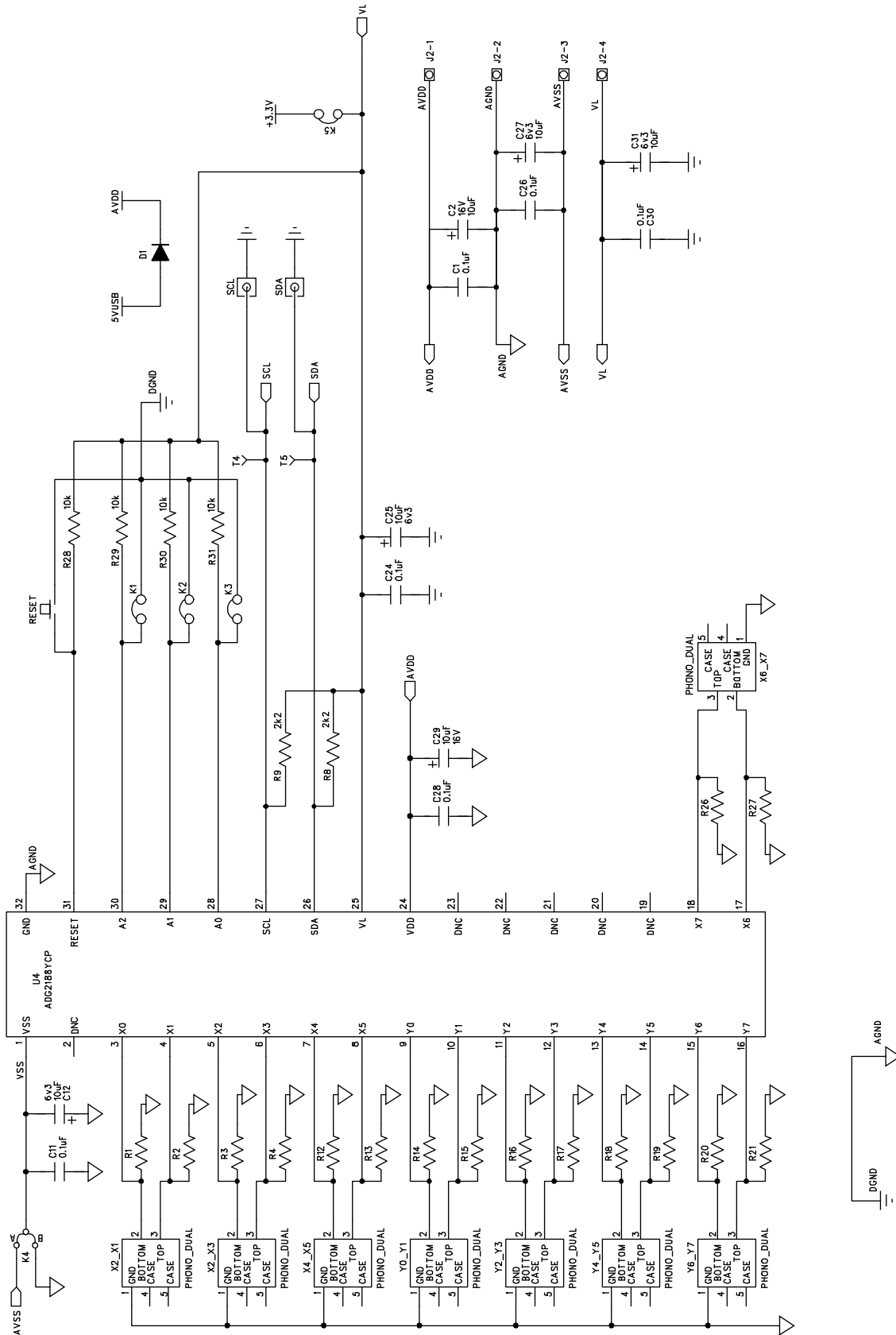
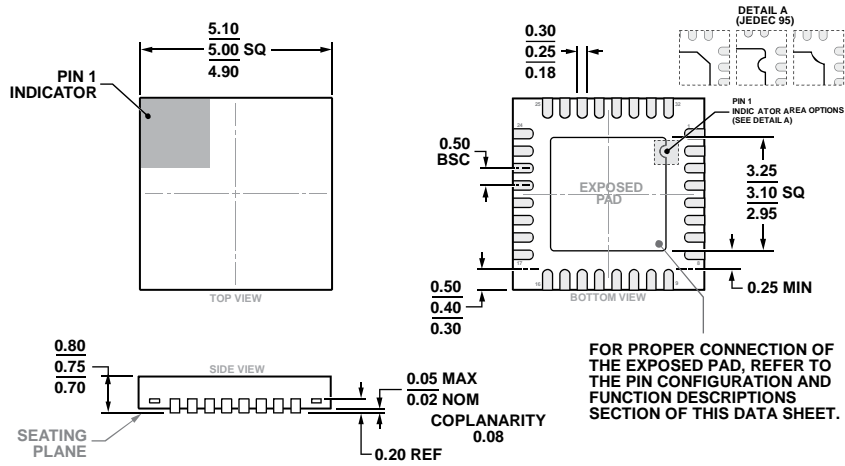

Figure 37. EVAL-ADG2188EB Schematic, Chip Section

05897-042

OUTLINE DIMENSIONS



COMPLIANT TO JEDEC STANDARDS MO-220-WHHD

Figure 38. 32-Lead Lead Frame Chip Scale Package [LFCSP]
 5 mm x 5 mm Body and 0.75 mm Package Height
 (CP-32-7)
 Dimensions shown in millimeters

ORDERING GUIDE

Model ^{1, 2}	Temperature Range	I ² C Speed	Package Description	Package Option
ADG2188BCPZ-REEL7	-40°C to +85°C	100 kHz, 400 kHz	32-Lead Lead Frame Chip Scale Package [LFCSP]	CP-32-7
ADG2188YCPZ-REEL7	-40°C to +125°C	100 kHz, 400 kHz	32-Lead Lead Frame Chip Scale Package [LFCSP]	CP-32-7
ADW54012Z-0REEL7	-40°C to +85°C	100 kHz, 400 kHz	32-Lead Lead Frame Chip Scale Package [LFCSP]	CP-32-7
EVAL-ADG2188EBZ			8 x 8 Evaluation Board	

¹ Z = RoHS Compliant Part.

² W = Qualified for Automotive Applications.

AUTOMOTIVE PRODUCTS

The ADW54012 model is available with controlled manufacturing to support the quality and reliability requirements of automotive applications. Note that this automotive model may have specifications that differ from the commercial models; therefore, designers should review the Specifications section of this data sheet carefully. Only the automotive grade products shown are available for use in automotive applications. Contact your local Analog Devices account representative for specific product ordering information and to obtain the specific Automotive Reliability reports for these models.

NOTES

I²C refers to a communications protocol originally developed by Philips Semiconductors (now NXP Semiconductors).

Данный компонент на территории Российской Федерации

Вы можете приобрести в компании MosChip.

Для оперативного оформления запроса Вам необходимо перейти по данной ссылке:

<http://moschip.ru/get-element>

Вы можете разместить у нас заказ для любого Вашего проекта, будь то серийное производство или разработка единичного прибора.

В нашем ассортименте представлены ведущие мировые производители активных и пассивных электронных компонентов.

Нашей специализацией является поставка электронной компонентной базы двойного назначения, продукции таких производителей как XILINX, Intel (ex.ALTERA), Vicor, Microchip, Texas Instruments, Analog Devices, Mini-Circuits, Amphenol, Glenair.

Сотрудничество с глобальными дистрибьюторами электронных компонентов, предоставляет возможность заказывать и получать с международных складов практически любой перечень компонентов в оптимальные для Вас сроки.

На всех этапах разработки и производства наши партнеры могут получить квалифицированную поддержку опытных инженеров.

Система менеджмента качества компании отвечает требованиям в соответствии с ГОСТ Р ИСО 9001, ГОСТ РВ 0015-002 и ЭС РД 009

Офис по работе с юридическими лицами:

105318, г.Москва, ул.Щербаковская д.3, офис 1107, 1118, ДЦ «Щербаковский»

Телефон: +7 495 668-12-70 (многоканальный)

Факс: +7 495 668-12-70 (доб.304)

E-mail: info@moschip.ru

Skype отдела продаж:

moschip.ru

moschip.ru_4

moschip.ru_6

moschip.ru_9