



R60D

DC Operated Rotary Variable Inductance Transducer

SPECIFICATIONS

- ◆ Lower cost than RVDTs
- ◆ Bipolar DC operation
- ◆ ± 60 degree sensing range
- ◆ High level VDC output
- ◆ Light-weight
- ◆ Non-contact electrical design
- ◆ Size 11 servo mount
- ◆ Anodized aluminum housing

The **R60D** RVIT (Rotary Variable Inductance Transducer) is a DC operated non-contact angular position sensor. Operating on a ± 15 VDC supply, the R60D provides a smooth ± 7.5 VDC output proportional to angular position over a ± 60 degree sensing range.

The RVIT proprietary design utilizes a set of four printed circuit coils and a light-weight conductive spoiler to achieve superior performance with a low moment of inertia. During operation, the light weight spoiler rotates with the transducer shaft, differentially altering the inductance of the printed circuit planar coils. The resulting unbalance is precisely measured using a patented autoplex circuit. This signal is then converted to a linear DC output voltage, proportional to the angle of the rotor shaft. The digital circuit is extremely resistant to environmental disturbances such as EMI and RFI, and is compatible for use with most analog position feedback systems.

Calibrated for use over the full ± 60 degree sensing range, the R60D offers exceptional performance at a cost effective price. It also features a wide operating temperature range, infinite resolution, and an extremely long rotational cycle life.

FEATURES

- ◆ Wide temperature range
- ◆ ± 7.5 VDC output
- ◆ Internal voltage regulation
- ◆ Low moment of inertia
- ◆ Shielded ABEC 3 precision bearings
- ◆ Rugged aluminum housing

APPLICATIONS

- ◆ Ball valve position
- ◆ Throttle level position feedback
- ◆ Rotary actuator feedback
- ◆ Dancer arm position
- ◆ Reeler / Dereeler

PERFORMANCE SPECIFICATIONS

ELECTRICAL SPECIFICATIONS	
Input voltage	+/-15VDC ±10%
Input current	25mA maximum
Angular range	±60 degrees
Non linearity	±0.5% of FR
Output at range ends	+/-7.5VDC
Sensitivity	125mV/degree
Temp. coefficient of output	±0.02% of FRO per °F [0.036% of FRO per °C], over operating temperature range
Output current	5mA maximum
Output impedance	1Ω maximum
Non repeatability & hysteresis	0.1% of FRO maximum
Frequency response	200Hz @ -3dB
ENVIRONMENTAL AND MECHANICAL SPECIFICATIONS	
Operating temperature	-13°F to +185°F [-25°C to 85°C]
Storage temperature	-67°F to +257°F [-55°C to 125°C]
Mechanical angular range	360 degrees (no stops)
Bearings	Shielded ABEC 3 precision
Shaft diameter	3/16 inch [4.76mm]
Housing material	Aluminum, black anodized
Mounting	Size 11 servo mount BU-ORD
Maximum torque, unbalance	0.12 inch.ounce-force [8.6 gram-force.cm]
Shaft load capability	10 lb [4.5Kg] Axial or Radial
Electrical connection	4 lead wires, AWG 24, PTFE insulation, 12 inches [30cm] long
Weight	1.2 oz [34 grams]
IP 60529 rating	IP60

Notes:

All values are nominal unless otherwise noted

FR (Full Range) is the angular range, end to end; 2xA° for ±A° angular range

FRO (Full Range Output): Algebraic difference in outputs measured at the ends of the range

DIMENSIONS

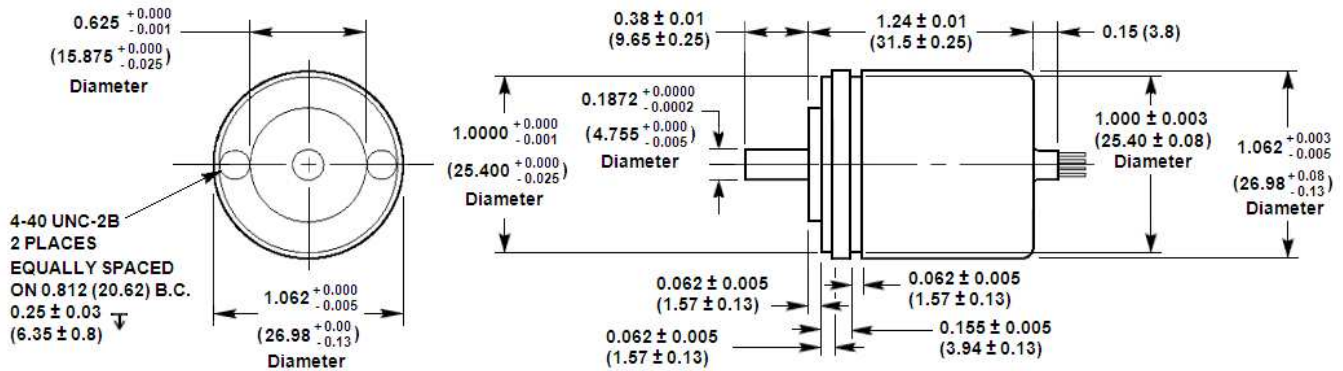

Dimensions are in inch (mm)

R60D

DC Operated Rotary Variable Inductance Transducer

WIRING INFORMATION

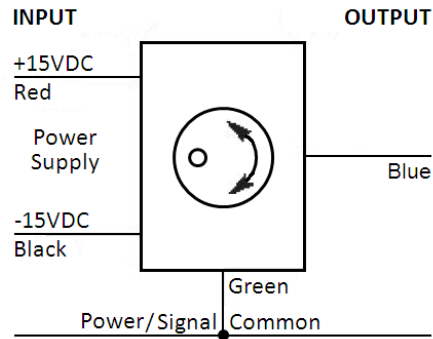

ORDERING INFORMATION

Description	Model	Part Number
RVIT $\pm 60^\circ$	R60D	02192500-060
ACCESSORIES		
R-FLEX multipurpose coupling kit	R-FLEX	66530072-000
Dual rail DC power supply (± 15 VDC)	PSD 40-15	02291339-000

NORTH AMERICA

Measurement Specialties, Inc.,
a TE Connectivity Company
Phone +1-800-522-6752
Email: customercare.hmpt@te.com

EUROPE

MEAS Deutschland GmbH(Europe)
a TE Connectivity Company
Phone: +49-800-440-5100
Email: customercare.dtmd@te.com

ASIA

Measurement Specialties (China), Ltd.,
a TE Connectivity Company
Phone: +86-0400-820-6015
Email: customercare.shzn@te.com

TE.com/sensorsolutions

Measurement Specialties, Inc., a TE Connectivity company.

Accustar, American Sensor Technologies, AST, ATEXIS, DEUTSCH, IdentiCal, TruBlue, KPSI, Krystal Bond, Microfused, UltraStable, Measurement Specialties, MEAS, Schaevitz, TE Connectivity, TE, and the TE connectivity (logo) are trademarks of the TE Connectivity Ltd. family of companies. Other logos, product and company names mentioned herein may be trademarks of their respective owners.

The information given herein, including drawings, illustrations and schematics which are intended for illustration purposes only, is believed to be reliable. However, TE Connectivity makes no warranties as to its accuracy or completeness and disclaims any liability in connection with its use. TE Connectivity's obligations shall only be as set forth in TE Connectivity's Standard Terms and Conditions of Sale for this product and in no case will TE Connectivity be liable for any incidental, indirect or consequential damages arising out of the sale, resale, use or misuse of the product. Users of TE Connectivity products should make their own evaluation to determine the suitability of each such product for the specific application.

Данный компонент на территории Российской Федерации

Вы можете приобрести в компании MosChip.

Для оперативного оформления запроса Вам необходимо перейти по данной ссылке:

<http://moschip.ru/get-element>

Вы можете разместить у нас заказ для любого Вашего проекта, будь то серийное производство или разработка единичного прибора.

В нашем ассортименте представлены ведущие мировые производители активных и пассивных электронных компонентов.

Нашей специализацией является поставка электронной компонентной базы двойного назначения, продукции таких производителей как XILINX, Intel (ex.ALTERA), Vicor, Microchip, Texas Instruments, Analog Devices, Mini-Circuits, Amphenol, Glenair.

Сотрудничество с глобальными дистрибьюторами электронных компонентов, предоставляет возможность заказывать и получать с международных складов практически любой перечень компонентов в оптимальные для Вас сроки.

На всех этапах разработки и производства наши партнеры могут получить квалифицированную поддержку опытных инженеров.

Система менеджмента качества компании отвечает требованиям в соответствии с ГОСТ Р ИСО 9001, ГОСТ РВ 0015-002 и ЭС РД 009

Офис по работе с юридическими лицами:

105318, г.Москва, ул.Щербаковская д.3, офис 1107, 1118, ДЦ «Щербаковский»

Телефон: +7 495 668-12-70 (многоканальный)

Факс: +7 495 668-12-70 (доб.304)

E-mail: info@moschip.ru

Skype отдела продаж:

moschip.ru

moschip.ru_4

moschip.ru_6

moschip.ru_9