

## LLC1 SERIES

### Open Board Liquid Level Controls

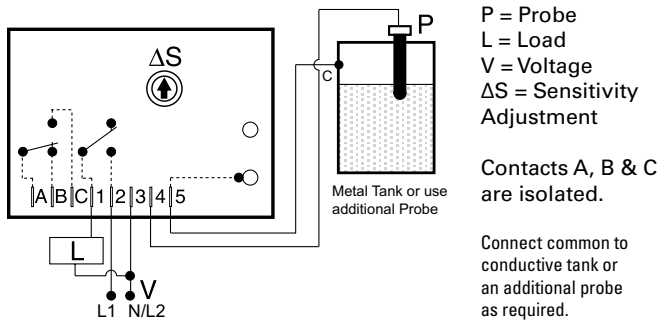

### Wiring Diagram



### Description

The LLC1 Series is a single probe conductive liquid level control designed for OEM equipment and commercial appliances. This unit may be ordered with fixed fill or fixed drain operation. A time delay (1-60s) prevents rapid cycling of the output relay. On adjustable units, the sensitivity adjustment allows accurate level sensing while ignoring foaming agents and floating debris. Isolated AC voltage is provided at the probe to prevent electrolysis. A trickle current of less than 1mA determines the presence or absence of liquid between the probe and common. The LLC1 Series printed circuit board is conformal coated to resist moisture and corrosion.

### Operation

**Drain (Pump-Down Mode):** When the liquid level rises and touches the probe, a fixed time delay begins. This time delay prevents rapid cycling of the output relay and its load. At the end of the time delay, the output relay energizes and remains energized until the liquid level falls below the probe. The output relay then de-energizes and remains de-energized until the liquid again touches the probe.

**Fill (Pump-Up Mode):** When the liquid level falls below the probe, a fixed time delay begins. This time delay prevents rapid cycling of the output relay and its load. At the end of the time delay, the output relay energizes and remains energized until the liquid level rises and touches the probe. The output relay then de-energizes and remains de-energized until the liquid level again falls below the probe.

### Features & Benefits

FEATURES	BENEFITS
<b>Isolated AC voltage on probe</b>	Prevents scale buildup on the probe
<b>Open PCB design</b>	Cost effective design for OEM equipment and commercial appliances
<b>Conformally coated PCB</b>	Protects against moisture and corrosion
<b>Sensitivity adjustment</b>	Provides accurate level sensing while ignoring foam or floating debris

### Ordering Information

MODEL	INPUT VOLTAGE	OPERATION	TIME DELAY	SENSE RESISTANCE	MOUNTING
LLC14A1AX	120VAC	Drain	1s	Adjustable	0.5 in nylon standoffs (3)
LLC14A5AX	120VAC	Drain	5s	Adjustable	0.5 in nylon standoffs (3)
LLC14B15AX	120VAC	Fill	15s	Adjustable	0.5 in nylon standoffs (3)
LLC14B1AX	120VAC	Fill	1s	Adjustable	0.5 in nylon standoffs (3)
LLC14B60AX	120VAC	Fill	60s	Adjustable	0.5 in nylon standoffs (3)
LLC16A25AX	230VAC	Drain	25s	Adjustable	0.5 in nylon standoffs (3)
LLC16A3AX	230VAC	Drain	3s	Adjustable	0.5 in nylon standoffs (3)

If you don't find the part you need, call us for a custom product 800-843-8848

## LLC1 SERIES

### Accessories



**P1015-13** (AWG 10/12), **P1015-64** (AWG 14/16), **P1015-14** (AWG 18/22) **Female Quick Connect**  
These 0.25 in. (6.35 mm) female terminals are constructed with an insulator barrel to provide strain relief.



**P1015-18 Quick Connect to Screw Adapter**  
Screw adapter terminal designed for use with all modules with 0.25 in. (6.35 mm) male quick connect terminals.



**PHST-38QTN Electrode**  
Designed for a maximum steam pressure of 240 PSI; 400° F. UL353 Recognized.



**LLP-24 Threaded Probe (24")**  
Threaded stainless steel probe measuring 24" (61 cm) long. For use with PHST-38QTN liquid level control electrodes.

### Specifications

<b>Control Type</b>	ON/OFF (single level) resistance sensor with built-in time delay to prevent rapid cycling
<b>Sense Voltage</b>	Low voltage AC between probe & common. Isolated from input & output.
<b>Sense Resistance</b>	Fixed or adjustable to 250K $\Omega$
<b>Sense Resistance Tolerance</b>	Adjustable - guaranteed range Factory fixed $\pm 10\%$
<b>Time Delay Range</b>	Fixed 1 - 60s in 1s increments
<b>Input Voltage Tolerance</b>	24, 120, or 230VAC
<b>24VAC Tolerance</b>	-15% - 20%
<b>120 &amp; 230VAC Tolerance</b>	-20% - 10%
<b>AC Line Frequency</b>	50/60 Hz
<b>Output Type</b>	Electromechanical relay
<b>Form</b>	Non-isolated, SPST & Isolated, SPDT contacts
<b>Rating</b>	10A resistive @ 120/240VAC & 28VDC; 1/3 hp @ 120/240VAC
<b>Life</b>	Mechanical - $1 \times 10^7$ ; Electrical - $1 \times 10^5$
<b>Protection Surge</b>	IEEE C62.41-1991 Level A
<b>Isolation Voltage</b>	$\geq 1500V$ RMS between input, output & probe
<b>Mechanical Mounting</b>	Surface mount to probe common with two #6 (M3.5 x 0.6) screws or 0.50 in. (12.7 mm) nylon standoffs with three #6 (M3.5 x 0.6) screws (use Terminal 5 for probe common)
<b>Termination</b>	0.25 in. (6.35 mm) male quick connect terminals
<b>Dimensions (Open Board)</b>	<b>H</b> 88.9 mm (3.5"); <b>W</b> 69.9 mm (2.75"); <b>D</b> 50.8 mm (2.0")
<b>Environmental Operating/Storage Temperature</b>	-20° to 55°C/-40° to 80°C
<b>Coating</b>	Printed circuit board is conformal coated to resist moisture and corrosion
<b>Weight</b>	$\approx 8.7$ oz (247 g)

## Данный компонент на территории Российской Федерации

### Вы можете приобрести в компании MosChip.

Для оперативного оформления запроса Вам необходимо перейти по данной ссылке:

<http://moschip.ru/get-element>

Вы можете разместить у нас заказ для любого Вашего проекта, будь то серийное производство или разработка единичного прибора.

В нашем ассортименте представлены ведущие мировые производители активных и пассивных электронных компонентов.

Нашей специализацией является поставка электронной компонентной базы двойного назначения, продукции таких производителей как XILINX, Intel (ex.ALTERA), Vicor, Microchip, Texas Instruments, Analog Devices, Mini-Circuits, Amphenol, Glenair.

Сотрудничество с глобальными дистрибьюторами электронных компонентов, предоставляет возможность заказывать и получать с международных складов практически любой перечень компонентов в оптимальные для Вас сроки.

На всех этапах разработки и производства наши партнеры могут получить квалифицированную поддержку опытных инженеров.

Система менеджмента качества компании отвечает требованиям в соответствии с ГОСТ Р ИСО 9001, ГОСТ РВ 0015-002 и ЭС РД 009

### Офис по работе с юридическими лицами:

105318, г.Москва, ул.Щербаковская д.3, офис 1107, 1118, ДЦ «Щербаковский»

Телефон: +7 495 668-12-70 (многоканальный)

Факс: +7 495 668-12-70 (доб.304)

E-mail: [info@moschip.ru](mailto:info@moschip.ru)

Skype отдела продаж:

moschip.ru

moschip.ru\_4

moschip.ru\_6

moschip.ru\_9