



Features

- Radial leaded devices
- Smaller size for similar Ihold rating
- Faster tripping
- RoHS compliant*

Applications

- Automotive applications
- Anywhere space is limited and fast tripping is required

MF-RG Series - PTC Resettable Fuses

Electrical Characteristics

Model	V max. Volts	I max. Amps	I _{hold}	I _{trip}	Initial Resistance		1 Hour (R ₁) Post-Trip Resistance	Max. Time To Trip		Tripped Power Dissipation
			Amperes at 23 °C		Ohms at 23 °C		Ohms at 23 °C	Amperes at 23 °C	Seconds at 23 °C	Watts at 23 °C
			Hold	Trip	Min.	Max.	Max.			Typ.
MF-RG300	16	100	3.00	5.10	0.038	0.065	0.0975	15	1.0	2.30
MF-RG500	16	100	5.00	8.50	0.015	0.023	0.0340	25	2.0	2.60

Environmental Characteristics

Operating/Storage Temperature.....	-40 °C to +85 °C	
Maximum Device Surface Temperature in Tripped State	125 °C	
Passive Aging.....	+85 °C, 1000 hours..... ±5 % typical resistance change	
Humidity Aging.....	+85 °C, 85 % R.H. 1000 hours	±5 % typical resistance change
Thermal Shock	-40 °C to +85 °C, 10 times.....	±10 % typical resistance change
Solvent Resistance.....	MIL-STD-202, Method 215	No change
Vibration	MIL-STD-883C, Method 2007.1,.....	No change Condition A

Test Procedures And Requirements For Model MF-RG Series

Test	Test Conditions	Accept/Reject Criteria
Visual/Mech.....	Verify dimensions and materials.....	Per MF physical description
Resistance.....	In still air @ 23 °C.....	R _{min} ≤ R ≤ R _{max}
Time to Trip.....	5 times I _{hold} , V _{max} , 23 °C.....	T ≤ max. time to trip (seconds)
Hold Current.....	30 min. at I _{hold}	No trip
Trip Cycle Life.....	V _{max} , I _{max} , 100 cycles.....	No arcing or burning
Trip Endurance.....	V _{max} , 48 hours.....	No arcing or burning

Thermal Derating Chart - I_{hold} (Amps)

Model	Ambient Operating Temperature								
	-40 °C	-20 °C	0 °C	23 °C	40 °C	50 °C	60 °C	70 °C	85 °C
MF-RG300	4.4	4.0	3.6	3.0	2.6	2.4	2.1	1.9	1.4
MF-RG500	7.3	6.6	6.0	5.0	4.4	4.0	3.6	3.1	2.4

I_{trip} is approximately two times I_{hold}.

MF-RG Series - PTC Resettable Fuses

BOURNS®

Product Dimensions

Model	A Max.	B Max.	C		D Min.	E Max.	F Nom.	Physical Characteristics		
			Nom.	Tol. ±				Style	Lead Dia.	Material
MF-RG300	7.1 (0.280)	11.0 (0.433)	5.1 (0.201)	0.7 (0.028)	7.6 (0.299)	3.0 (0.118)	0.81 (0.032)	1	0.81 (0.032)	Sn/Cu
MF-RG500	10.4 (0.409)	14.3 (0.563)	5.1 (0.201)	0.7 (0.028)	7.6 (0.299)	3.0 (0.118)	0.81 (0.032)	1	0.81 (0.032)	Sn/Cu

Packaging options:

BULK: 500 pcs. per bag. TAPE & REEL: 3000 pcs. per reel. AMMO-PACK: 2000 pcs. per reel.

0.81 (20AWG)

DIMENSIONS: $\frac{\text{MM}}{\text{(INCHES)}}$

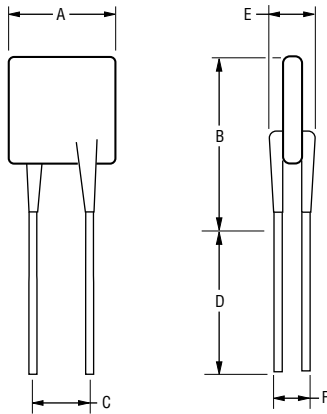

Typical Part Marking

Represents total content. Layout may vary.

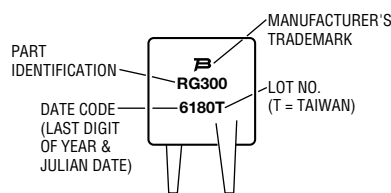

How to Order

MF - RG 300 - 0

Multifuse® Product Designator _____

Series _____
 RG = Smaller Radial Leaded Component

Hold Current, I_{hold} _____
 300-500 (3.0 Amps - 5.0 Amps)

Packaging Options _____
 - 0 = Bulk Packaging
 - 2 = Tape and Reel
 - AP = Ammo-Pak

NOTE: Kinked leads are available for board standoff options. Contact factory for details.

Typical Time to Trip at 23 °C

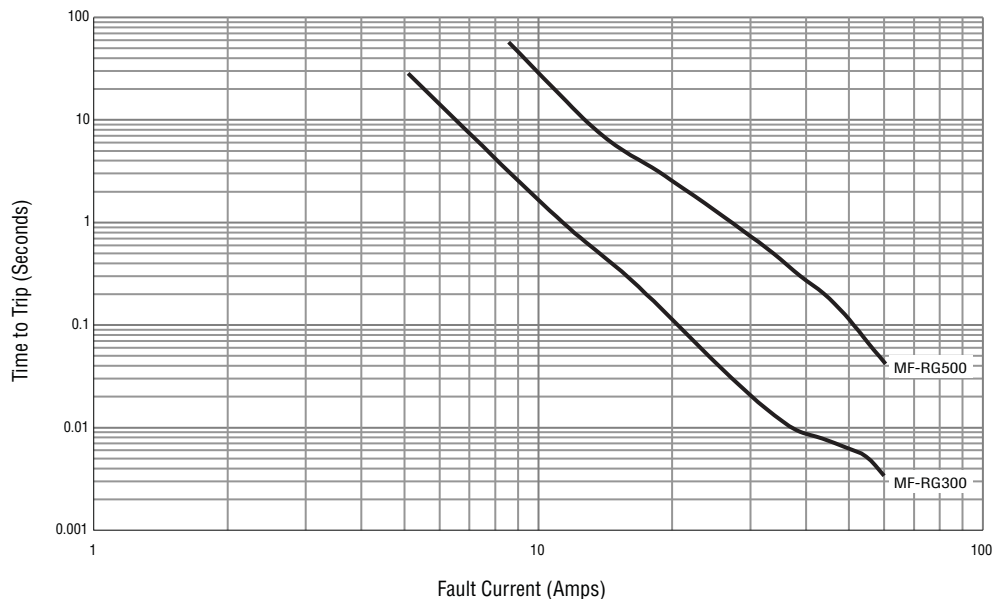

MF-RG SERIES, REV. F, 05/12

Specifications are subject to change without notice.

Customers should verify actual device performance in their specific applications.

MF-RG Series Tape and Reel Specifications

BOURNS®

Devices taped using EIA468-B/IEC60286-2 standards. See table below and Figures 1 and 2 for details.

Dimension Description	IEC Mark	EIA Mark	Dimensions	
			Dimensions	Tolerance
Carrier tape width	<i>W</i>	<i>W</i>	$\frac{18}{(.709)}$	$\frac{-0.5/+1.0}{(-0.02/+0.039)}$
Hold down tape width: all others		<i>W4</i>	$\frac{11}{(.433)}$	min.
Hold down tape	<i>W0</i>		No protrusion	
Top distance between tape edges	<i>W2</i>	<i>W6</i>	$\frac{3}{(.118)}$	max.
Sprocket hole position	<i>W1</i>	<i>W5</i>	$\frac{9}{(.354)}$	$\frac{-0.5/+0.75}{(-0.02/+0.03)}$
Sprocket hole diameter	<i>D0</i>	<i>D0</i>	$\frac{4}{(.157)}$	$\frac{\pm 0.2}{(\pm .0078)}$
Abscissa to plane (straight lead)	<i>H</i>	<i>H</i>	$\frac{18.5}{(.728)}$	$\frac{\pm 3.0}{(\pm .118)}$
Abscissa to plane (kinked lead)	<i>H0</i>	<i>H0</i>	$\frac{16}{(.63)}$	$\frac{\pm 0.5}{(\pm .02)}$
Abscissa to top (straight lead)	<i>H1</i>	<i>H1</i>	$\frac{38.0}{(1.496)}$	max.
Abscissa to top (kinked lead)	<i>H1</i>	<i>H1</i>	$\frac{32.2}{(1.268)}$	max.
Overall width w/lead protrusion (straight lead)		<i>C1</i>	$\frac{55.0}{(2.165)}$	max.
Overall width w/lead protrusion (kinked lead)		<i>C1</i>	$\frac{43.2}{(1.7)}$	max.
Overall width w/o lead protrusion (straight lead)		<i>C2</i>	$\frac{54.0}{(2.126)}$	max.
Overall width w/o lead protrusion (kinked lead)		<i>C2</i>	$\frac{42.5}{(1.673)}$	max.
Lead protrusion	<i>I1</i>	<i>L1</i>	$\frac{1.0}{(.039)}$	max.
Protrusion of cutout	<i>L</i>	<i>L</i>	$\frac{11}{(.433)}$	max.
Protrusion beyond hold-down tape	<i>I2</i>	<i>I2</i>	Not specified	
Sprocket hole pitch	<i>P0</i>	<i>P0</i>	$\frac{12.7}{(0.5)}$	$\frac{\pm 0.3}{(\pm .012)}$
Pitch tolerance			20 consecutive	$\frac{\pm 1}{(\pm .039)}$
Device pitch:			$\frac{12.7}{(0.5)}$	
Tape thickness	<i>t</i>	<i>t</i>	$\frac{0.9}{(.035)}$	max.
Tape thickness with splice:		<i>t1</i>	$\frac{2.0}{(.079)}$	max.
Splice sprocket hole alignment			$\frac{4.0}{(.157)}$	$\frac{\pm 0.2}{(\pm .008)}$
Body lateral deviation	Δh	Δh	0	$\frac{\pm 1}{(\pm .039)}$
Body tape plane deviation	Δp	Δp	0	$\frac{\pm 0.3}{(\pm .051)}$
Lead seating plane deviation	$\Delta P1$	<i>P1</i>	$\frac{3.81}{(.015)}$	$\frac{\pm 0.7}{(\pm .028)}$
Lead spacing:	<i>F</i>	<i>F</i>	$\frac{8.0}{(.315)}$	
Reel width	<i>w</i>	<i>w</i>	$\frac{56.0}{(2.20)}$	max.
Reel diameter	<i>d</i>	<i>a</i>	$\frac{370.0}{(14.57)}$	max.
Space between flanges less device			$\frac{4.75}{(.187)}$	$\frac{\pm 3.25}{(\pm .128)}$

Specifications are subject to change without notice.
Customers should verify actual device performance in their specific applications.

DIMENSIONS = $\frac{\text{MM}}{\text{(INCHES)}}$

MF-RG Series Tape and Reel Specifications

BOURNS®

Dimension Description	IEC Mark	EIA Mark	Dimensions	
			Dimensions	Tolerance
Arbor hole diameter	<i>f</i>	<i>c</i>	$\frac{26.0}{(1.02)}$	$\frac{\pm 12.0}{(\pm .472)}$
Core diameter	<i>h</i>	<i>n</i>	$\frac{80.0}{(3.15)}$	max.
Box			$\frac{64}{(2.52)}$ $\frac{372}{(14.6)}$ $\frac{362}{(14.25)}$	max.
Consecutive missing places			3	max.
Empty places per reel			Not specified	

Taped Component Dimensions - Figure 1



Reel Dimensions - Figure 2

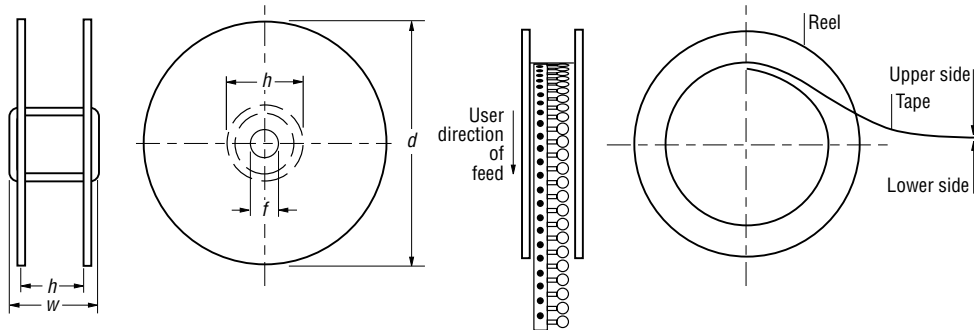

Данный компонент на территории Российской Федерации

Вы можете приобрести в компании MosChip.

Для оперативного оформления запроса Вам необходимо перейти по данной ссылке:

<http://moschip.ru/get-element>

Вы можете разместить у нас заказ для любого Вашего проекта, будь то серийное производство или разработка единичного прибора.

В нашем ассортименте представлены ведущие мировые производители активных и пассивных электронных компонентов.

Нашей специализацией является поставка электронной компонентной базы двойного назначения, продукции таких производителей как XILINX, Intel (ex.ALTERA), Vicor, Microchip, Texas Instruments, Analog Devices, Mini-Circuits, Amphenol, Glenair.

Сотрудничество с глобальными дистрибьюторами электронных компонентов, предоставляет возможность заказывать и получать с международных складов практически любой перечень компонентов в оптимальные для Вас сроки.

На всех этапах разработки и производства наши партнеры могут получить квалифицированную поддержку опытных инженеров.

Система менеджмента качества компании отвечает требованиям в соответствии с ГОСТ Р ИСО 9001, ГОСТ РВ 0015-002 и ЭС РД 009

Офис по работе с юридическими лицами:

105318, г.Москва, ул.Щербаковская д.3, офис 1107, 1118, ДЦ «Щербаковский»

Телефон: +7 495 668-12-70 (многоканальный)

Факс: +7 495 668-12-70 (доб.304)

E-mail: info@moschip.ru

Skype отдела продаж:

moschip.ru

moschip.ru_4

moschip.ru_6

moschip.ru_9