

---

**LT3755-2, LT3755-1**  
**HIGH VOLTAGE LED CONTROLLER****DESCRIPTION**

Demonstration circuit 1268B-A, 1268B-B is a high voltage and high current LED driver controller. The VIN pin input voltage is as high as 40V. The LED output voltage on this board is as high as 60V but can be set as high as 75V. The demonstration circuit is assembled as a boost topology from 8-40V input and up to 54V LED output at 1A with an open LED status pin (-A) or a sync input pin (-B). DC1268B features PWM dimming, analog dimming, shutdown, and open LED overvoltage protection. Efficiency at 12VIN is as high as 93% for 50W output.

The switching frequency is set at 400kHz to accommodate the automotive switching frequency range. Small ceramic input and output capacitors are used to save space and cost and a high voltage 60V external power switch and a 60V catch diode are used for up to 54W (54V at 1A) output as assembled. The open LED overvoltage protection will limit the output to approximately 56V if the LED string is opened. For low input voltage operation, the CTRL pin voltage is reduced as the input voltage drops below 9V, reducing LED brightness and restraining the peak switch currents in order to limit inductor and switch size. UVLO turns the LEDs off when VIN drops below 8V.

DC1268B PWM dimming is simple. The boost topology LED string returns to the LED- terminal and the PWM dimming MOSFET turns the LED string on and off given an input to the PWM dimming terminal. For the highest pwm dimming ratio, it is recommended to use 100Hz as a pwm dimming frequency. Information

regarding PWM dimming ratios and performance can be found in the LT3755-2/-1 datasheet in the applications section.

Soft-start is provided with a simple and small capacitor to maintain control of the switch current during turn on for high power designs.

Modifications can be made to the DC1268B in order to convert the board from a boost topology LED driver to any other topology. Buck-boost mode, buck mode, and SEPIC schematics are provided in the datasheet. Please consult the factory or LT3755-2/-1 datasheet for details regarding how to customize the DC1268B or how to design different topologies for custom specifications.

The LT3755-2, LT3755-1 datasheet gives a complete description of the part, operation and applications information. The datasheet must be read in conjunction with this Quick Start Guide for demonstration circuit 1268B-A, 1268B-B. The LT3755-2, LT3755-1 is assembled in a small 16-lead plastic QFN package with a thermally enhanced ground pad. Proper board layout is essential for maximum thermal performance. See the datasheet section 'Layout Considerations'.

**Design files for this circuit board are available. Call the LTC factory.**

---

LT is a trademark of Linear Technology Corporation

**Table 1. Typical Performance Summary for DC1268B-A/B**

PARAMETER	CONDITION	VALUE (TYPICAL)
Input Voltage PVIN Range	Operating	8V-40V
Switching Frequency	R8 = 28.7k	400kHz
I <sub>LED</sub>		1A
Maximum Output Voltage - Open LED Voltage		56V
Efficiency	PVIN=12V V <sub>LED</sub> =50V I <sub>LED</sub> =1A	93%
Under Voltage Lockout		8V
Peak Switch Current Limit	RS1 = 0.015Ω	6.6A

## QUICK START PROCEDURE

Demonstration circuit 1268B-A, 1268B-B is easy to set up to evaluate the performance of the LT3755-2, LT3755-1. Follow the procedure below:

**NOTE:** Make sure that the PVIN DC input voltage does not exceed 40V.

1. Connect a string of LEDs with forward voltage less than 54V, but greater than the PVIN voltage, to the LED+ and LED- (Boost) terminals on the PCB as shown in Figure 1.
2. Connect the shutdown terminal to GND.
3. With power off, connect the PVIN power supply to the PVIN and GND terminals within the ranges specified on the PCB.

4. Connect the PWM terminal. If PWM is not used, connect PWM to a 5V source or to IntVcc on the PCB. PWM must be pulled high to work. For -B, see the section in the datasheet regarding PWM dimming and the SYNC input.
5. Turn the PVIN power supply on.
6. Release the shutdown/GND connection.
7. Observe the LED string running at the programmed LED current.
8. For PWM dimming, connect a PWM 100Hz or higher signal to the PWM terminal.
9. Observe the reduction of brightness in the LED string when PWM dimming.

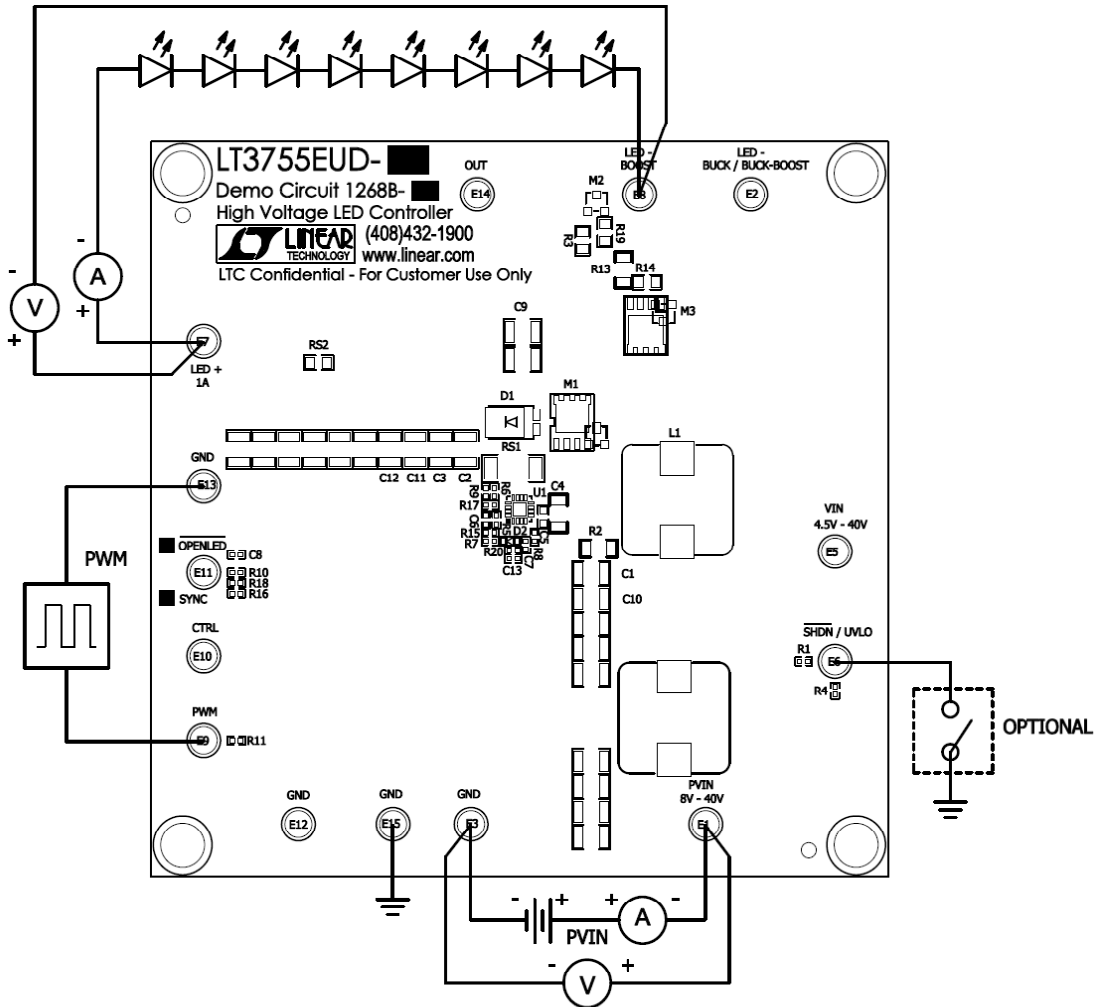

Figure 1. Test procedure setup drawing for DC1268B-A and DC1268B-B

## TWO ICS -2 AND -1

DC1268B features two build versions. DC1268B-A uses the LT3755EUD-2 with an open LED status and DC1268B-B uses the LT3755EUD-1 with sync. Each board is clearly marked indicating which IC is used. The open LED indicator terminal has a pull-up resistor to the internal 7V regulator IntVcc. Note that when PWM and SYNC are both used, optimal PWM dimming occurs when there is at least a

200ns delay from the PWM rising edge and the SYNC rising edge – with the PWM edge occurring first. For more questions regarding this matter, please consult the factory.

Although DC1268B-A/B is assembled as a boost topology LED driver, it can be reconfigured for buck-boost mode, buck mode and SEPIC LED driver topologies. A few schematics featuring these other topologies are included in the datasheet. Please keep in mind that the chosen topology should reflect the relationship between the entire input voltage range and the LED voltage range. Other circuit requirements such as short circuit be-

tween terminals or ground can be affected by the choice of LED driver topology.

## TERMINAL OPTIONS

DC1268B-A/B has both PVIN and VIN terminals. The schematic shows that the PVIN and VIN terminals are shorted together with a resistor. As assembled, only the PVIN terminal needs 8V to 40V power in order for the board to operate. However, resistor R2 can be removed and the VIN terminal can be connected to a separate supply from the PVIN terminal. The VIN terminal is tied directly to the VIN pin.

The OUT terminal is available for the customer to monitor the state of the output capacitor directly. The OUT terminal can also be used as an input for buck mode topology.

The PWM terminal must be pulled high in order for the board to operate. It is preferred that the PWM terminal/pin is tied to IntVcc of the controller if PWM dimming is not used, but for board evaluation it can be tied to an external 5V source as well.

The CTRL terminal is used for analog dimming. The CTRL pin is tied directly to the terminal and it is already being used to reduce the LED current when VIN drops too low. The CTRL pin voltage can easily be overridden with an external voltage supply and the resistor divider from PVIN can be removed.

The shutdown/undervoltage lockout terminal is used to shut down the demonstration circuit. Tie the terminal to GND and the converter stops switching. The PWMOUT pin goes low and the PWM dimming MOSFET is turned off. As long as the PWM dimming MOSFET is used properly, the LEDs do not turn on during shutdown.

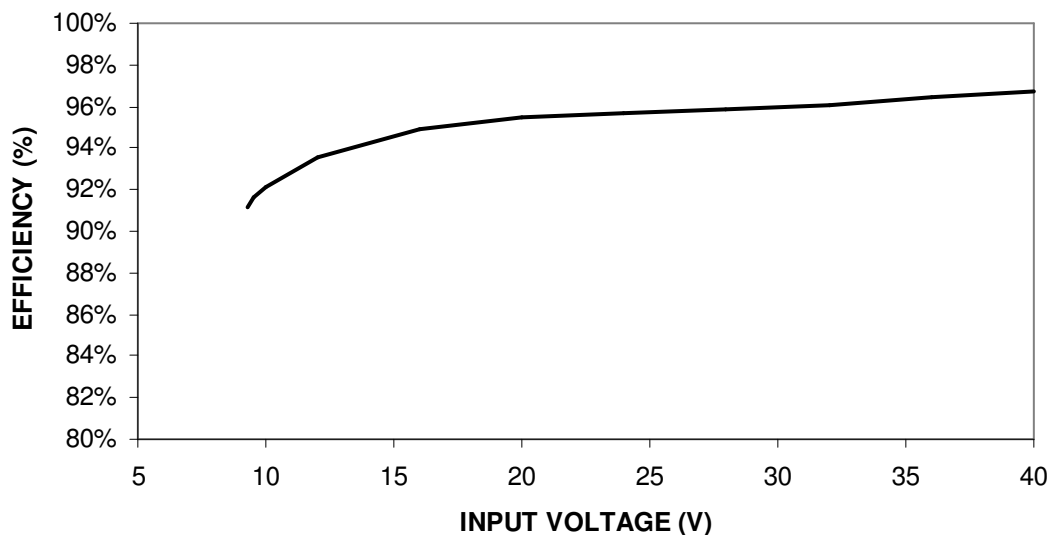

Figure 2. DC1268B-A/B Efficiency with 50V LEDs at 1A

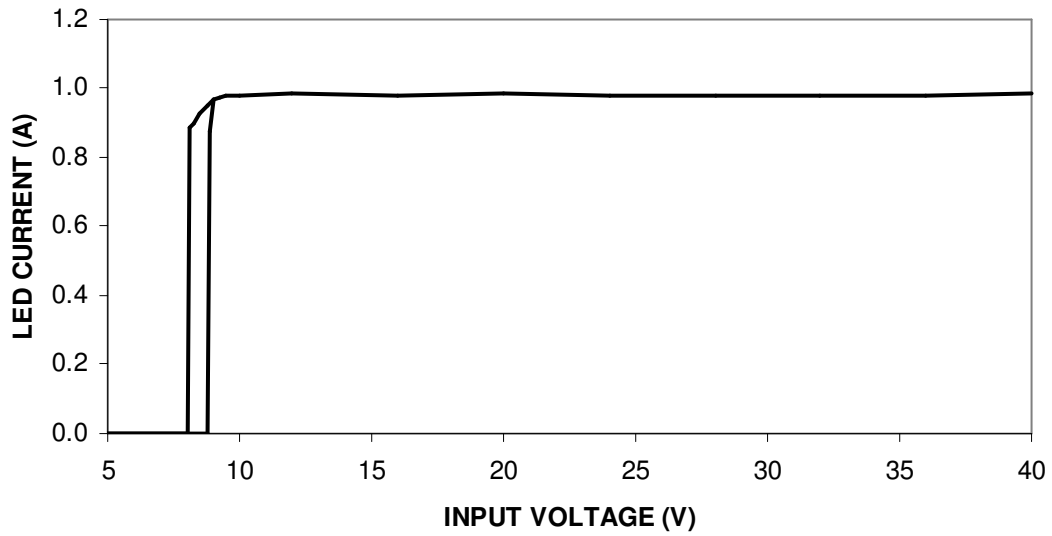
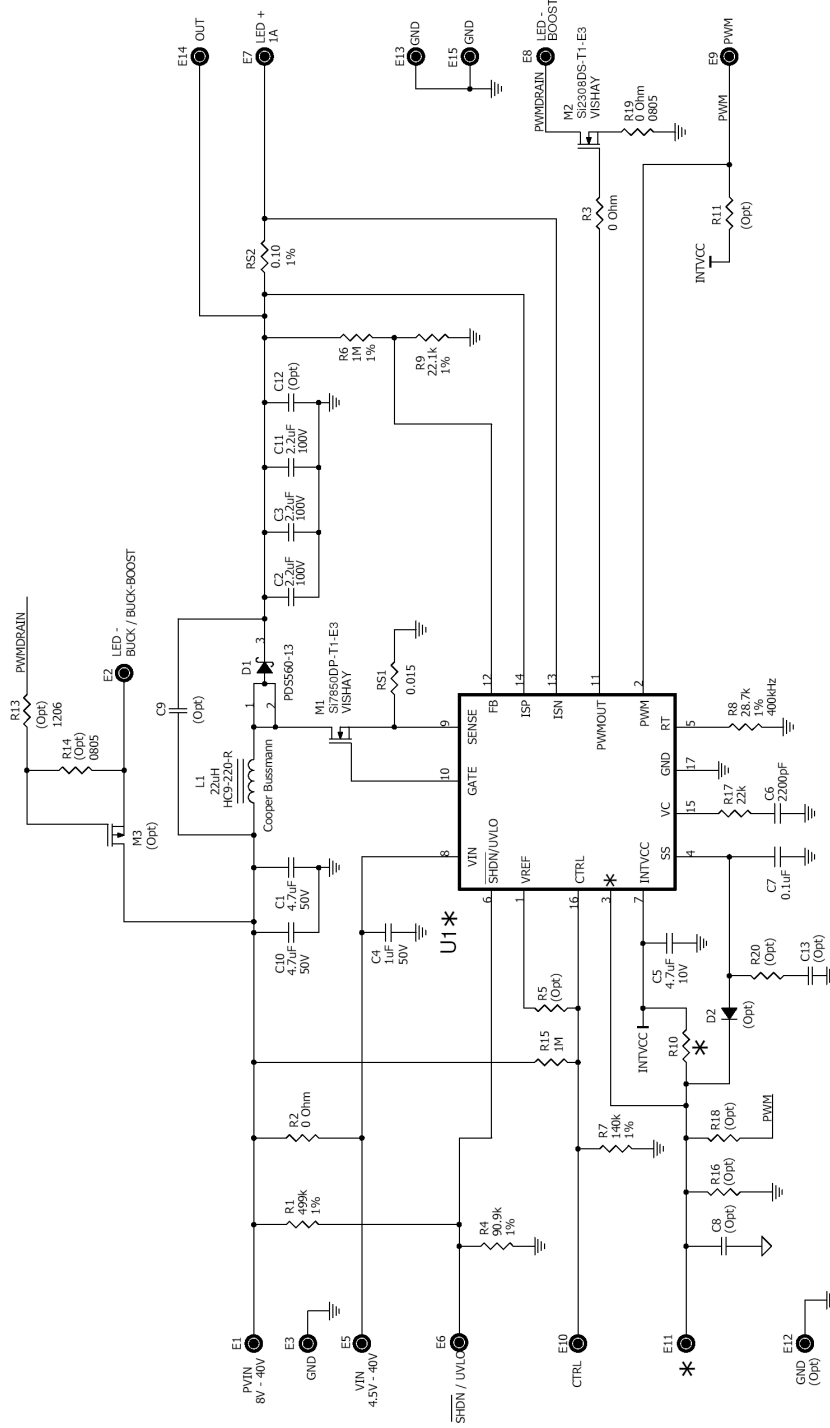

Figure 3. DC1268B-A/B LED Current Drops at Low VIN (CTRL) and Turns Off at Lower VIN (UVLO)

REVISION #		REVISION HISTORY		APPROVED	
SD	PC	AD	FD	DESCRIPTION	DATE
0	0	0	0	1st Release	
1	1	1	1	(-) Change R20, C13, D2 to Opt. C7 to 0.1uF, 07/02/09	kz

This circuit is proprietary to Linear Technology and supplied for use with Linear Technology parts.  
**Customer Notice:** Linear Technology has made a best effort to design a circuit that meets customer-supplied specifications. However, the user is responsible for component selection, proper substitution and printed circuit board layout may significantly affect circuit performance or reliability. Contact Linear Applications Engineering for assistance.



APPROVALS		LINEAR TECHNOLOGY CORPORATION	
DRAWN: Rudy Boudreau		1630 MCCARTHY BLVD	
ENGINEER: Keith Szolusha		MILPITAS, CA 95035	
APPROVED:		LTC Confidential - For Customer Use Only	
CHECKED:		Title: LT3755EUD-1/2 High Voltage LED Controller	
Date: Thursday, July 02, 2009		Document Number: Demo Circuit 1268B	
		C:\ORCAD\WINCAP\PIURE\1268B\1268B_00_REV1.DSN	
		Sheet 1 of 1	

ASSEMBLY	U1 (IC)	U1-3 (Name)	E11 (Name)	R10
-A	LT3755EUD-2	OPENED	OPENED	100k
-B	LT3755EUD-1	SYNC	SYNC	OPT

## Данный компонент на территории Российской Федерации

### Вы можете приобрести в компании MosChip.

Для оперативного оформления запроса Вам необходимо перейти по данной ссылке:

<http://moschip.ru/get-element>

Вы можете разместить у нас заказ для любого Вашего проекта, будь то серийное производство или разработка единичного прибора.

В нашем ассортименте представлены ведущие мировые производители активных и пассивных электронных компонентов.

Нашей специализацией является поставка электронной компонентной базы двойного назначения, продукции таких производителей как XILINX, Intel (ex.ALTERA), Vicor, Microchip, Texas Instruments, Analog Devices, Mini-Circuits, Amphenol, Glenair.

Сотрудничество с глобальными дистрибьюторами электронных компонентов, предоставляет возможность заказывать и получать с международных складов практически любой перечень компонентов в оптимальные для Вас сроки.

На всех этапах разработки и производства наши партнеры могут получить квалифицированную поддержку опытных инженеров.

Система менеджмента качества компании отвечает требованиям в соответствии с ГОСТ Р ИСО 9001, ГОСТ РВ 0015-002 и ЭС РД 009

### Офис по работе с юридическими лицами:

105318, г.Москва, ул.Щербаковская д.3, офис 1107, 1118, ДЦ «Щербаковский»

Телефон: +7 495 668-12-70 (многоканальный)

Факс: +7 495 668-12-70 (доб.304)

E-mail: [info@moschip.ru](mailto:info@moschip.ru)

Skype отдела продаж:

moschip.ru

moschip.ru\_4

moschip.ru\_6

moschip.ru\_9