

Evaluation board circuit diagram
and implementation
<MN63Y1208>

Ver 1.2

2013/3/1

Semiconductor Business Group
Industrial Devices Company
Panasonic Corporation

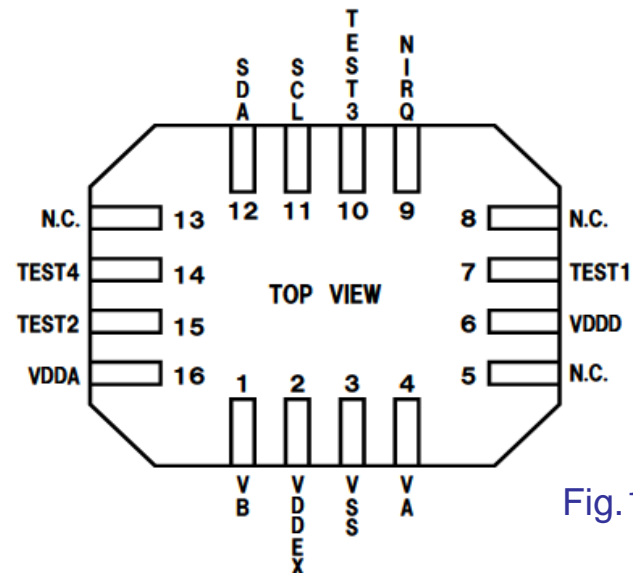
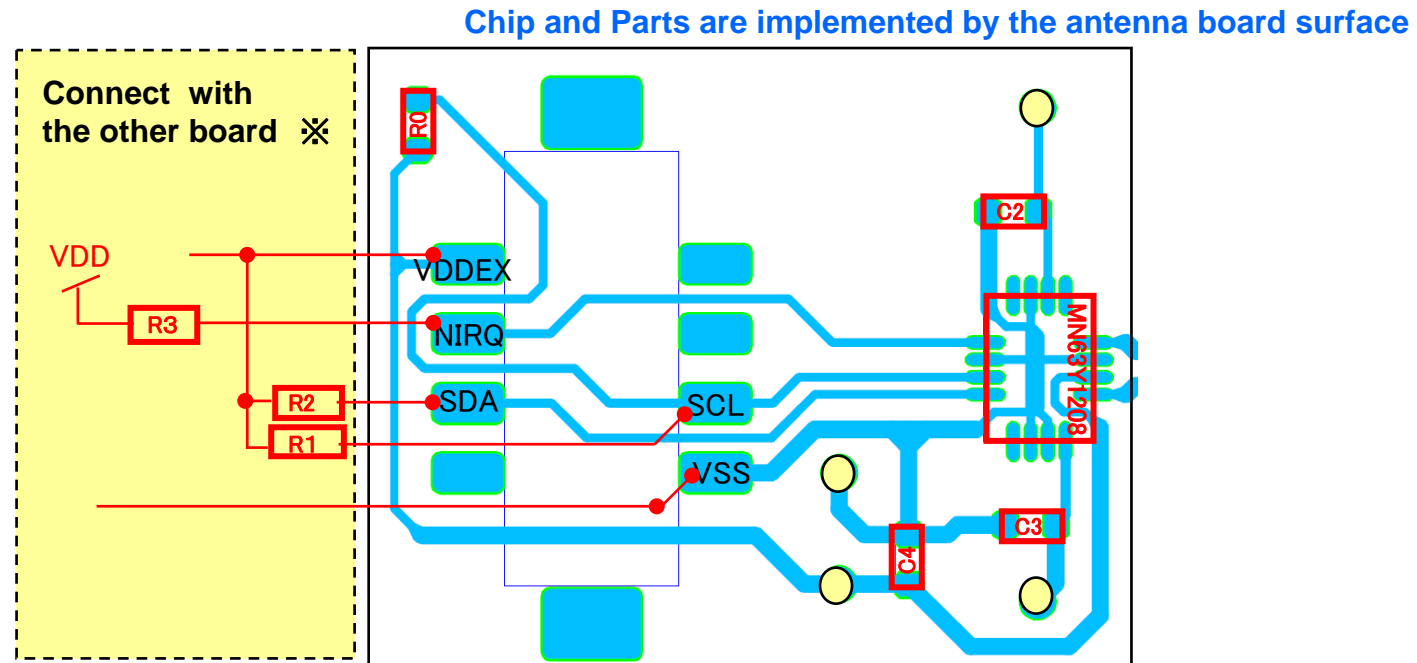

Fig.1 List of pin placement

Tab.1 Pins of the NFC tag

PIN Number	Terminal name	Input/output	Input and output type	function
1	VB	I/O	—	Coil terminal
2	VDDEX	—	Power	Power supply for contact (Input 1.7V ~ 3.6V)
3	VSS	—	GND	Ground
4	VA	I/O	—	Coil terminal
5	N.C.	—	—	Unconnected pin
6	VDDD	—	Power	Digital internal power supply (Connect capacitance between VSS)
7	TEST1	input	—	Test control (Normally connected to VSS)
8	N.C.	—	—	Unconnected pin
9	NIRQ	output	Open Drain	Interrupt request output
10	TEST3	input	—	Test control (Normally connected to VSS)
11	SCL	input	—	HOST I/F (I2C 100kHz)
12	SDA	I/O	Open Drain	HOST I/F (I2C 100kHz)
13	N.C.	—	—	Unconnected pin
14	TEST4	input	—	Test control (Normally connected to VSS)
15	TEST2	input	—	Test control (Normally connected to VSS)
16	VDDA	—	Power	Analog internal power supply (Connect capacitance between VSS)



External part	Recommendation Value	Detailed explanation
R1,R2	3.3k Ω	It is pulling up resistance for I2C signal lines.Please decide the resistance level in consideration of transmission rate, wiring capacity, current ability. In our NFC tag board "ANT4030_02_0505_B0_L," it is not implemented.
R3	3.3k Ω	It is pulling up resistance for interrupt signal lines. Please decide the resistance level in consideration of wiring capacity, current ability. In our NFC tag board "ANT4030_02_0505_B0_L," it is not implemented.
C2、C3、C4	0.1 μ F	It is a fixed value at the capacity between the power supply for operation stabilization of the tag LSI. C2 is connected to VDDD, and C3 is connected to VDDA and C4 is connected to VDDEX
R0	100k Ω	It is pulling up resistance to prevent an uncertainty state of SCL causing the malfunction. When NFC tag LSI has the terms of use that R1 is not connected to, I am necessary.

* I connect pulling up resistance (R,R2,R3) to the microcomputer board of our offer.

Chip and Parts are implemented by the board surface

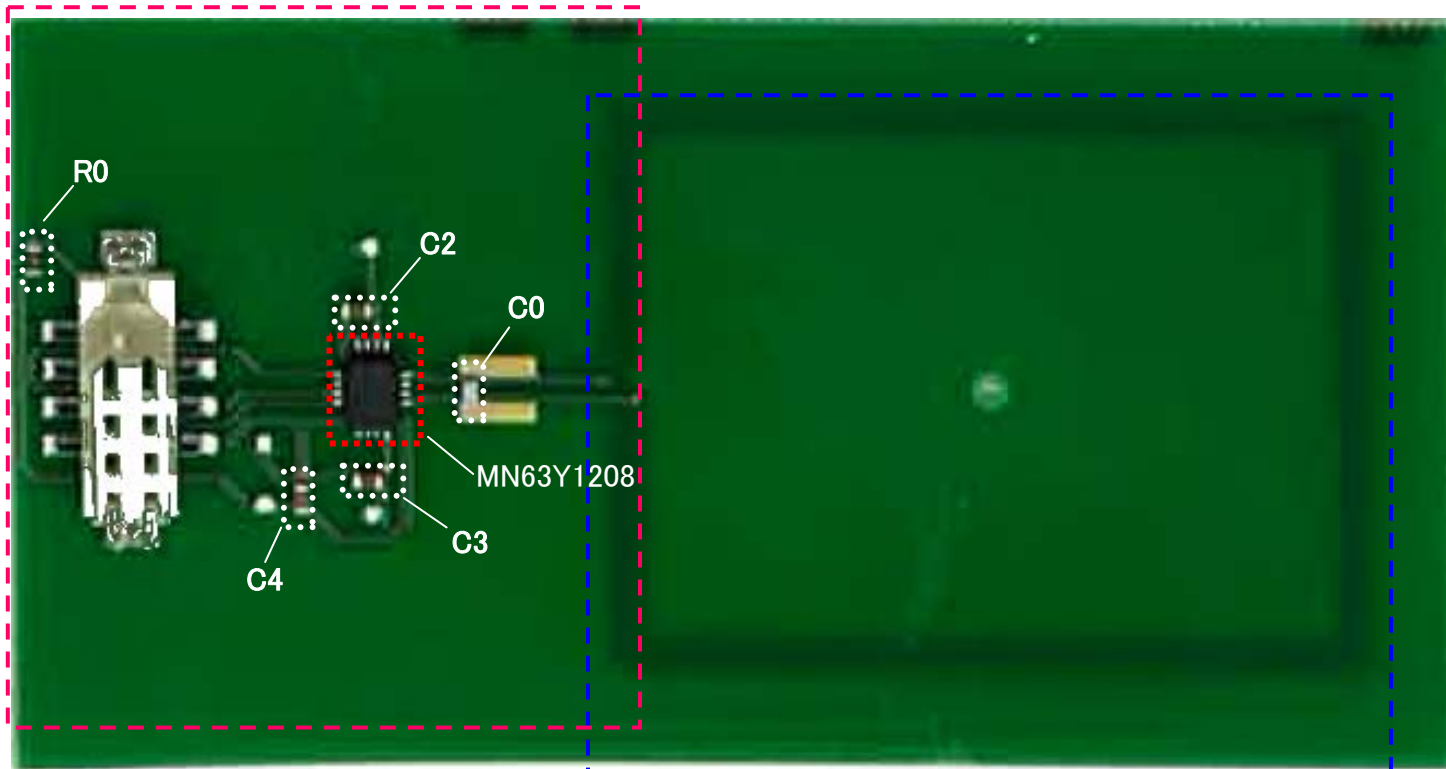

Antenna is implemented by the board back side

Connection image

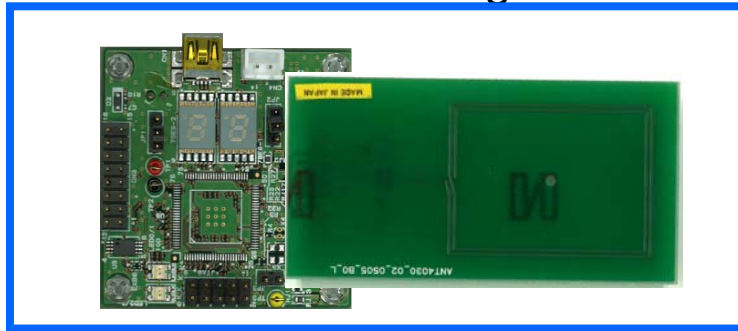

Micon Board [BTPB101-B]

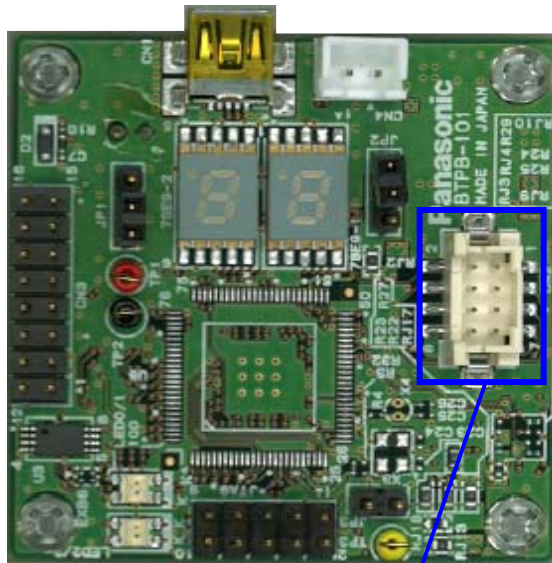

Antenna Board [ANT4030_02_0505_B0_L]

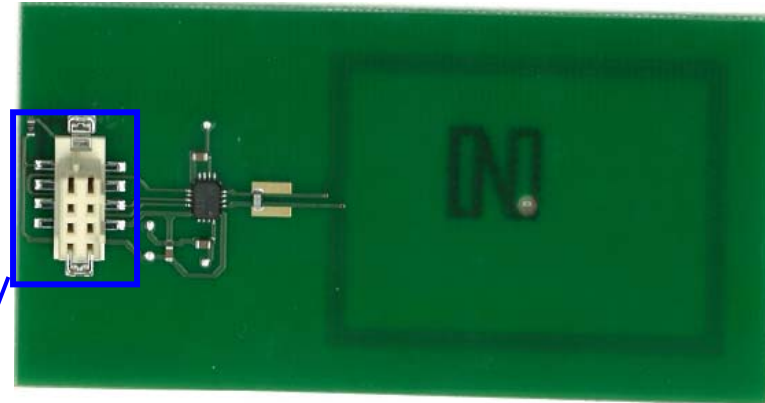

DF11CZ-8DP-2V(27)
(Hirose Electric)

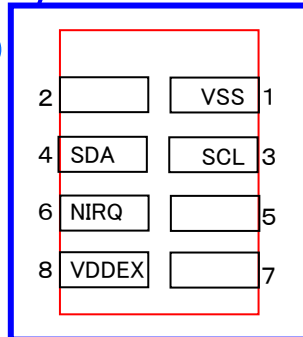

HRS DF11CZ- 8DS-2V
(Hirose Electric)

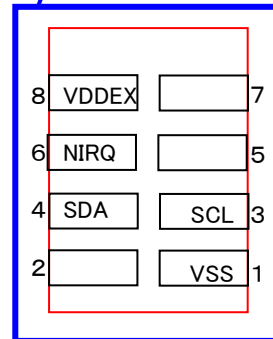

Request for your special attention and precautions in using the technical information and semiconductors described in this book

- (1) If any of the products or technical information described in this book is to be exported or provided to non-residents, the laws and regulations of the exporting country, especially, those with regard to security export control, must be observed.
- (2) The technical information described in this book is intended only to show the main characteristics and application circuit examples of the products. No license is granted in and to any intellectual property right or other right owned by Panasonic Corporation or any other company. Therefore, no responsibility is assumed by our company as to the infringement upon any such right owned by any other company which may arise as a result of the use of technical information described in this book.
- (3) The products described in this book are intended to be used for general applications (such as office equipment, communications equipment, measuring instruments and household appliances), or for specific applications as expressly stated in this book. Consult our sales staff in advance for information on the following applications:
 - Special applications (such as for airplanes, aerospace, automotive equipment, traffic signaling equipment, combustion equipment, life support systems and safety devices) in which exceptional quality and reliability are required, or if the failure or malfunction of the products may directly jeopardize life or harm the human body.It is to be understood that our company shall not be held responsible for any damage incurred as a result of or in connection with your using the products described in this book for any special application, unless our company agrees to your using the products in this book for any special application.
- (4) The products and product specifications described in this book are subject to change without notice for modification and/or improvement. At the final stage of your design, purchasing, or use of the products, therefore, ask for the most up-to-date Product Standards in advance to make sure that the latest specifications satisfy your requirements.
- (5) When designing your equipment, comply with the range of absolute maximum rating and the guaranteed operating conditions (operating power supply voltage and operating environment etc.). Especially, please be careful not to exceed the range of absolute maximum rating on the transient state, such as power-on, power-off and mode-switching. Otherwise, we will not be liable for any defect which may arise later in your equipment.

Even when the products are used within the guaranteed values, take into the consideration of incidence of break down and failure mode, possible to occur to semiconductor products. Measures on the systems such as redundant design, arresting the spread of fire or preventing glitch are recommended in order to prevent physical injury, fire, social damages, for example, by using the products.
- (6) Comply with the instructions for use in order to prevent breakdown and characteristics change due to external factors (ESD, EOS, thermal stress and mechanical stress) at the time of handling, mounting or at customer's process. When using products for which damp-proof packing is required, satisfy the conditions, such as shelf life and the elapsed time since first opening the packages.
- (7) This book may be not reprinted or reproduced whether wholly or partially, without the prior written permission of our company.

Данный компонент на территории Российской Федерации

Вы можете приобрести в компании MosChip.

Для оперативного оформления запроса Вам необходимо перейти по данной ссылке:

<http://moschip.ru/get-element>

Вы можете разместить у нас заказ для любого Вашего проекта, будь то серийное производство или разработка единичного прибора.

В нашем ассортименте представлены ведущие мировые производители активных и пассивных электронных компонентов.

Нашей специализацией является поставка электронной компонентной базы двойного назначения, продукции таких производителей как XILINX, Intel (ex.ALTERA), Vicor, Microchip, Texas Instruments, Analog Devices, Mini-Circuits, Amphenol, Glenair.

Сотрудничество с глобальными дистрибьюторами электронных компонентов, предоставляет возможность заказывать и получать с международных складов практически любой перечень компонентов в оптимальные для Вас сроки.

На всех этапах разработки и производства наши партнеры могут получить квалифицированную поддержку опытных инженеров.

Система менеджмента качества компании отвечает требованиям в соответствии с ГОСТ Р ИСО 9001, ГОСТ РВ 0015-002 и ЭС РД 009

Офис по работе с юридическими лицами:

105318, г.Москва, ул.Щербаковская д.3, офис 1107, 1118, ДЦ «Щербаковский»

Телефон: +7 495 668-12-70 (многоканальный)

Факс: +7 495 668-12-70 (доб.304)

E-mail: info@moschip.ru

Skype отдела продаж:

moschip.ru

moschip.ru_4

moschip.ru_6

moschip.ru_9