

OUTPUT COUPLING CAPACITOR-LESS LOW VOLTAGE VIDEO AMPLIFIER WITH LPF

■ GENERAL DESCRIPTION

The NJU71032 is a Low Voltage Video Amplifier with LPF circuit. By the internal charge pump circuit, output capacitor is unnecessary.

The NJU71032 features low power and small package, and is suitable for low power design on downsizing of portable video system and system with video output.

- NJU71031 (Gain=6dB)

■ PACKAGE OUTLINE



NJU71032RB1
MSOP8(TVSP8)

■ FEATURES

- Operating Voltage 2.5 to 3.45V
- Output coupling capacitor-less
- 6dB amplifier
- Internal 75Ω Driver Circuit (2-system drive)
- Internal LPF 0dB at 6.75MHz typ
 -40dB at 54MHz typ
- Power Save Circuit
- CMOS Technology
- Package Outline MSOP8(TVSP8)*

*MEET JEDEC MO-187-DA / THIN TYPE

■ PIN CONFIGURATION

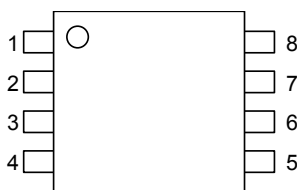

NJU71032RB1

- 1: CP1
- 2: V+
- 3: VIN
- 4: Power Save
- 5: VOUT
- 6: GND
- 7: V-
- 8: CP2

■ BLOCK DIAGRAM

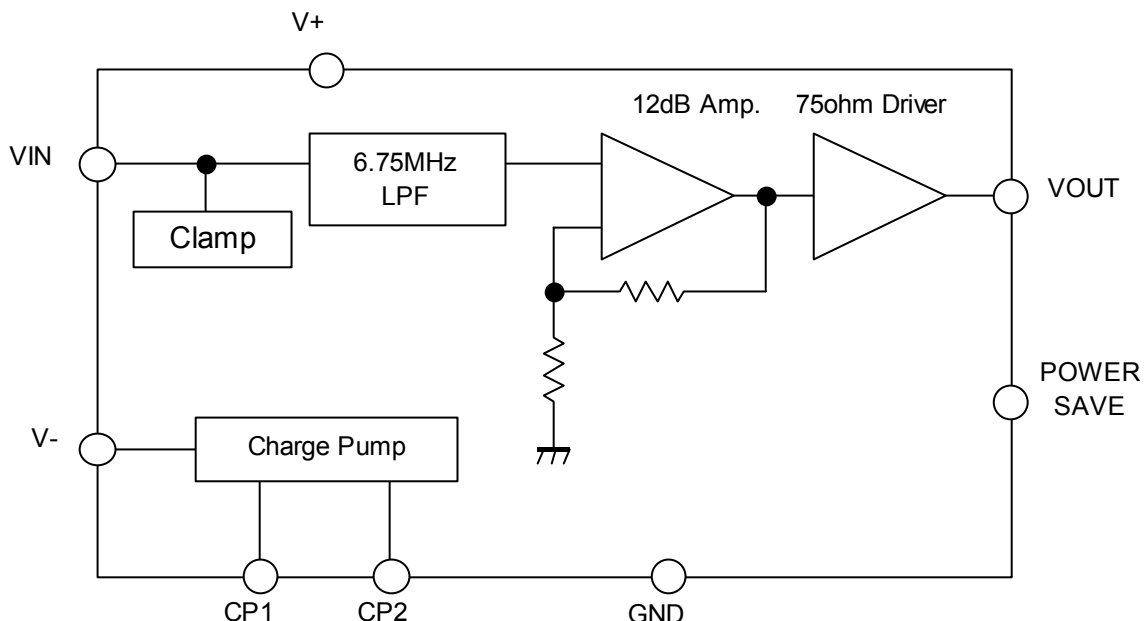

NJU71032

■ ABSOLUTE MAXIMUM RATINGS (Ta=25°C)

PARAMETER	SYMBOL	RATINGS	UNIT
Supply Voltage	V ⁺	3.55	V
Power Dissipation	P _D	MSOP8(TVSP8): 580 (Note1)	mW
Operating Temperature Range	Topr	-40 to +85	°C
Storage Temperature Range	Tstg	-55 to +150	°C

(Note 1) At on a board of EIA/JEDEC specification. (114.3 x 76.2 x 1.6mm 2 layers, FR-4)

■ RECOMMENDED OPERATING CONDITION (Ta=25°C)

PARAMETER	SYMBOL	TEST CONDITION	MIN.	TYP.	MAX.	UNIT
Operating Voltage	Vopr		2.5	-	3.45	V

■ ELECTRICAL CHARACTERISTICS (V⁺=3.0V, R_L=150Ω, Ta=25°C)

PARAMETER	SYMBOL	TEST CONDITION	MIN.	TYP.	MAX.	UNIT
Operating Current	I _{CC}	No Signal	-	14	22	mA
Operating Current at Power Save	I _{save}	No Signal, Power Save Mode	-	0.1	10	μA
Maximum Output Voltage Swing	V _{om}	f=100kHz, THD=1%	2.4	3.0	-	V _{p-p}
Voltage Gain	G _v	V _{in} =100kHz, 0.5V _{p-p} , Input Sine Signal	11.6	12.0	12.4	dB
Low Pass Filter Characteristic	G _{fy} 6.75M	V _{in} =6.75MHz/100kHz, 0.5V _{p-p}	-1.0	0	1.0	dB
	G _{fy} 54M	V _{in} =54MHz/100kHz, 0.5V _{p-p}	-	-40	-24	
Differential Gain	DG	V _{in} =0.5V _{p-p} , 10step Video Signal	-	0.5	-	%
Differential Phase	DP	V _{in} =0.5V _{p-p} , 10step Video Signal	-	0.5	-	deg
S/N Ratio	SN _v	100kHz to 6MHz, V _{in} =0.5V _{p-p} 100% White Video Signal, R _L =75Ω	-	+65	-	dB
Switching Noise Level	N _{swpl}	R _L =75Ω, 10% White Video Signal	-	4	7	mV _{pp}
SW Change Voltage High Level	V _{thPH}	Active	1.25	-	V ⁺	V
SW Change Voltage Low Level	V _{thPL}	Non-active	0	-	0.45	

■ CONTROL TERMINAL

PARAMETER	STATUS	NOTE
Power Save	H	Power Save: OFF
	L	Power Save: ON (Mute)
	OPEN	Power Save: ON (Mute)

■ TEST CIRCUIT

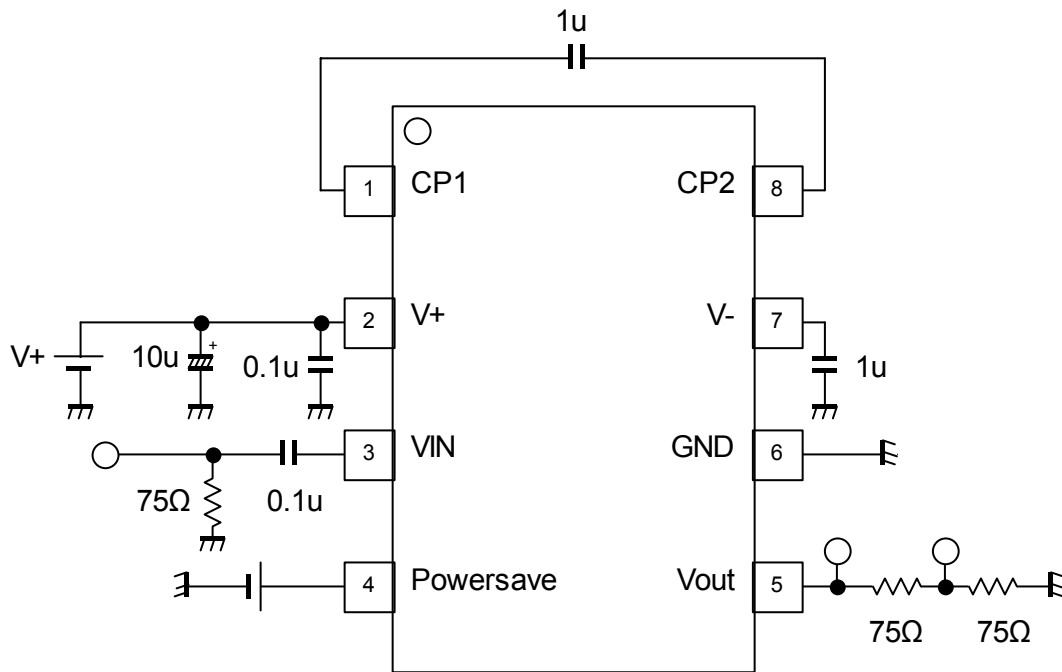

■ APPLICATION CIRCUIT 1 (Standard circuit)

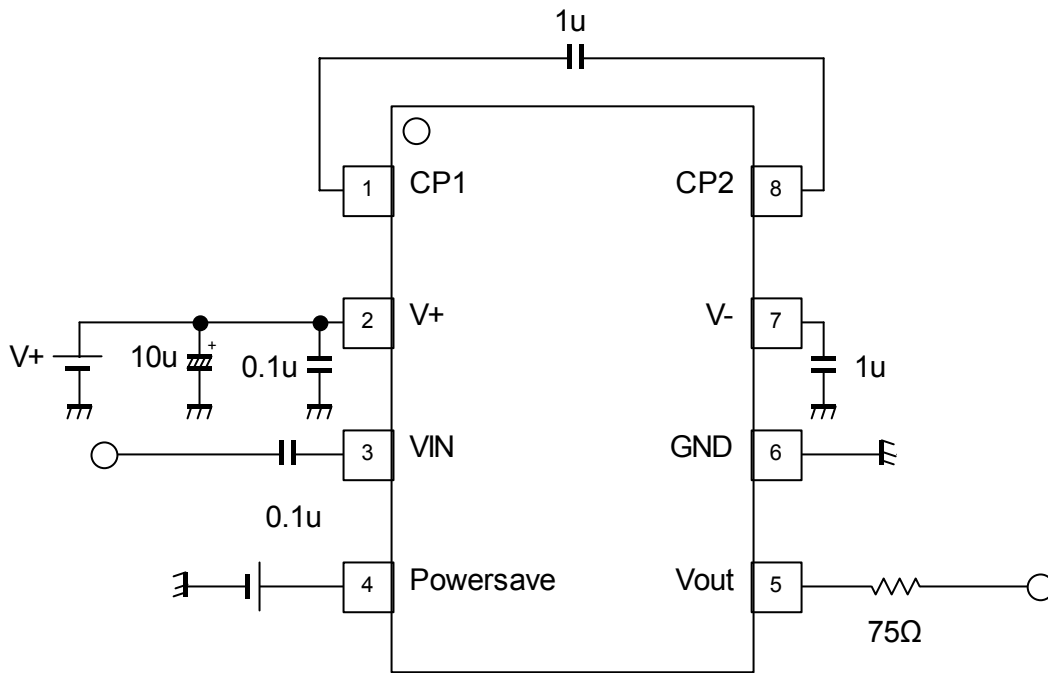

■ APPLICATION CIRCUIT 2 (Two-line drive circuit)

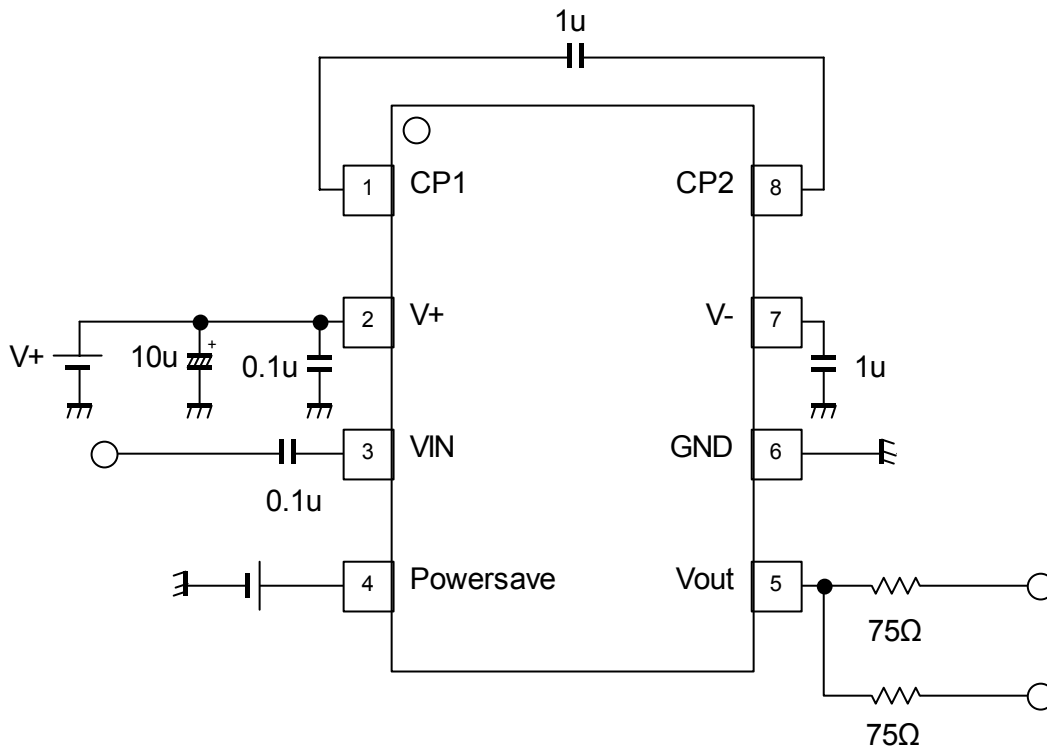

■ TERMINAL FUNCTION

PIN No.	PIN NAME	FUNCTION	EQUIVALENT CIRCUIT	DC VOLTAGE
1	CP1	Flying Capacitor Terminal		-
2	V+	V+ Power Supply	-	-
3	VIN	Input		0V
4	Power Save	Power Save		-
5	VOUT	Output		0V

Ver.2

NJU71032

PIN No.	PIN NAME	FUNCTION	EQUIVALENT CIRCUIT	DC VOLTAGE
6	GND	Ground	-	-
7	V-	V- Power Supply	-	-
8	CP2	Flying Capacitor Terminal		-

APPLICATION

When coax multiplex transmission, we recommend that you adjust the output signal. Please refer to figure1.

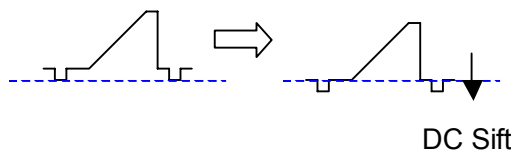
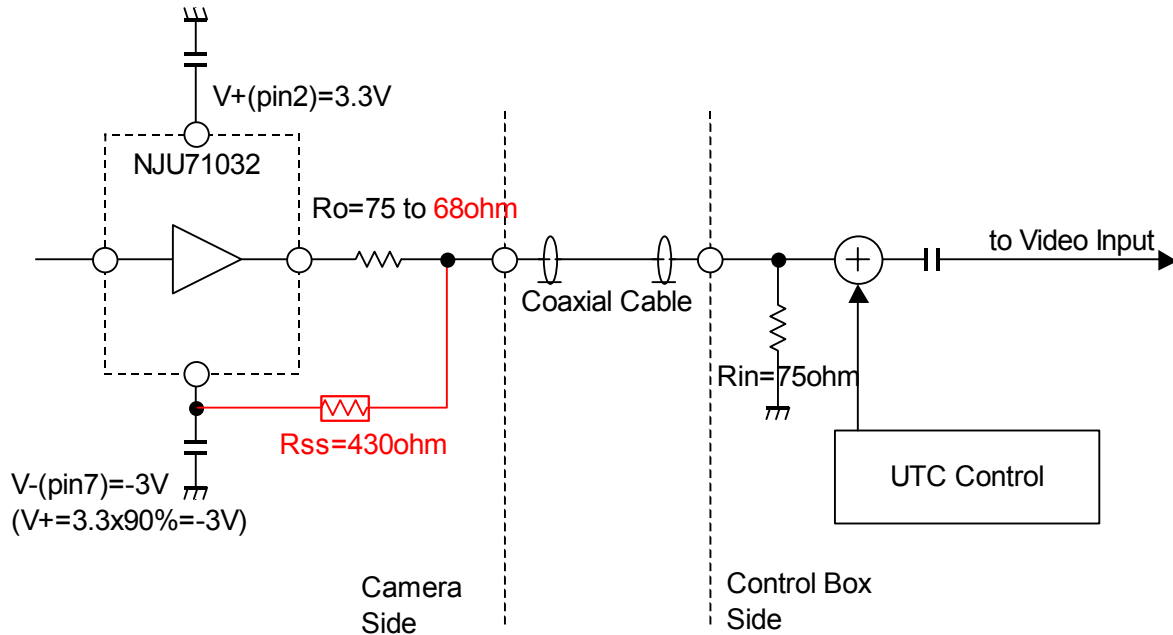

Figure1: How to shift the output DC signal

The rare case, there is to be superimposed the directly DC control signal on the video signal when superimposed a control signal to the video signal by using a coaxial cable.

In that case, the following symptoms will appear.

- The control signal appears on the screen.
- Loss of synchronization of the video signal

Shows the proposed measures on the next page.

A case of multiple coaxial transmission: UTC(Up The Coaxial)

This is one of a case at the multiplex coaxial transmission used in CCTV.

It is a system that control signals of camera multiplexing to the coaxial cable.

This system is superimposed on the control signal pulse in the vertical blanking period as shown in Figure 2.

This is because do not affect the video signal.

Case of Coaxitron

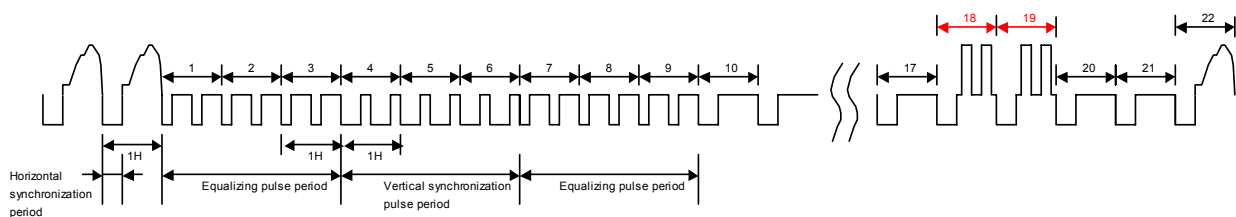

Figure2: A case of UTC

Ver.2

Proposed measures is shift the output DC signal by using the V- terminal (pin 7) of NJU71032.

The steps are as follows:

1. A resistor: Rss add between the Ro (75Ω) and V- terminal (7pin).

2. Reduce Ro (75Ω).

By adding a Rss, level of the video signal is attenuated.

Example: Level of the video signal will be reduced 5% at connected Rss = 430Ω and Ro = 75Ω.

Therefore, increase 5% of video output level by changed to 68Ω the Ro.

*Table 1 shows an external resistor value and the swing of video output signal at V+ (pin2) = 3.3V, 3V.

3. Please evaluation of S/N.

It is because the noise of the charge pump may change.

	Value (typ.)		UNIT
V+(pin2)	3.3	3	V
V-(pin7) (V+*90%)	-2.95	-2.67	V
Termination resistance	75	75	ohm
Resistance (between Vss and Vout)	430	430	ohm
Output resistance(Ro)	68	68	ohm
Sync. Voltage of Vout	-0.203	-0.19	V
Swing of Vout	0.975	0.975	Vpp

Table 1: external resistor value and the swind of video outout signal at V+ (pin2) = 3.3V, 3V.

• Case of 2-system 75ohm drive

Shown in Figure 3, 2-system drive will be possible at system 1 (75Ω for multiplex coaxial system) and system -2(75Ω system for monitoring).

However, shown in Figure 4, 2-system drive is not recommended, case of system 1and 2 (75Ω for multiplex coaxial system)

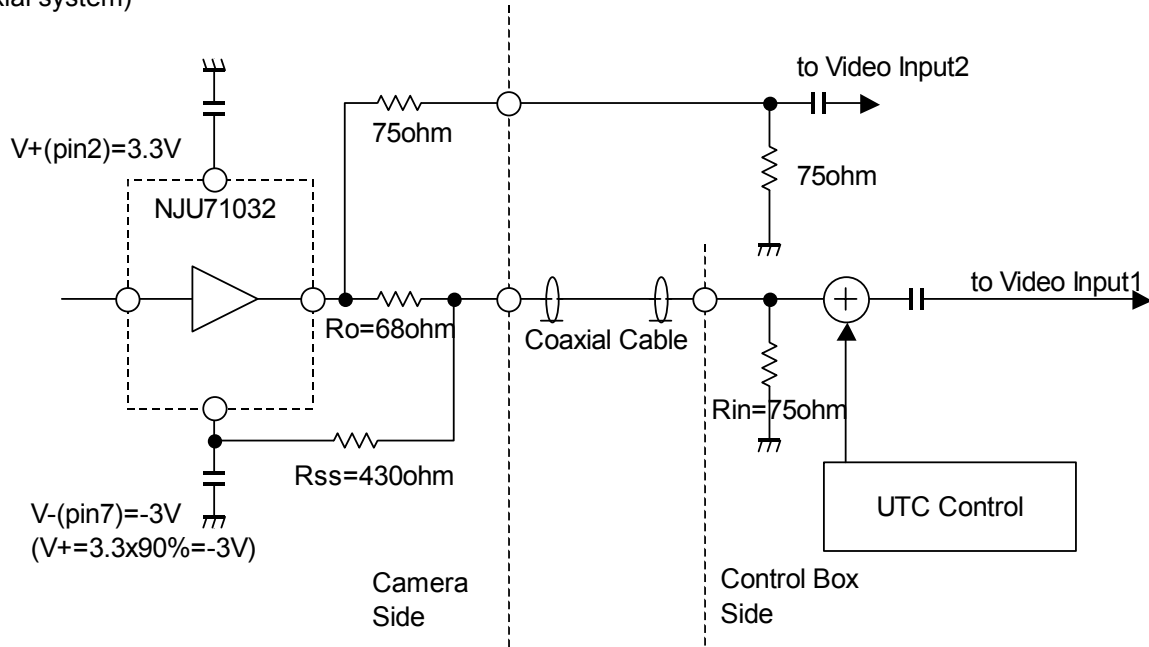

Figure 3: Recommended 2-system drive circuit

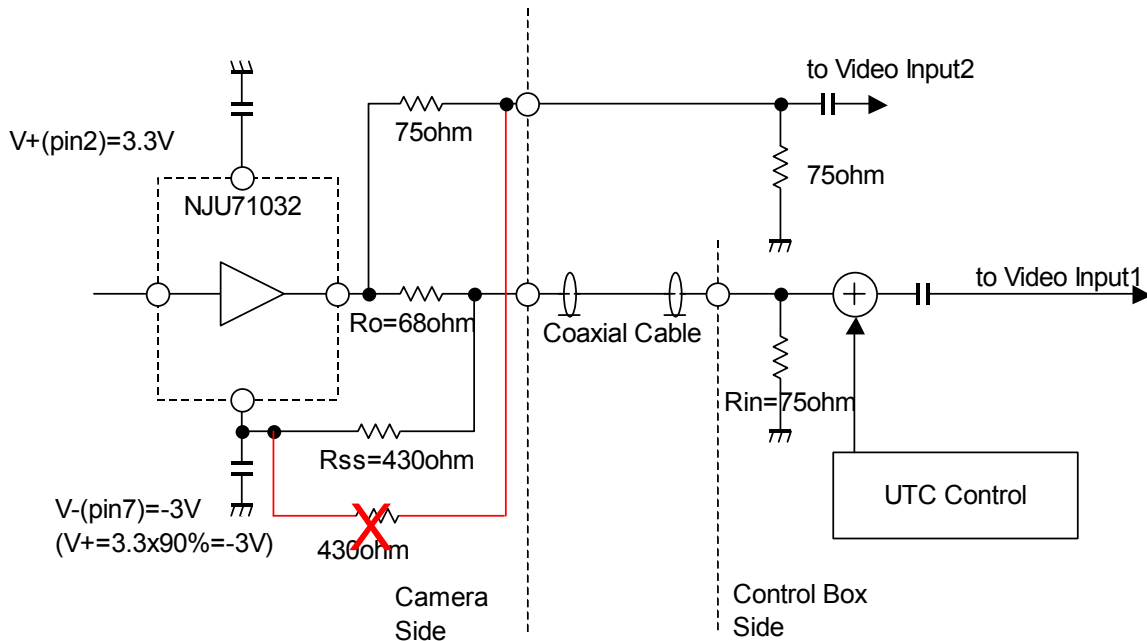
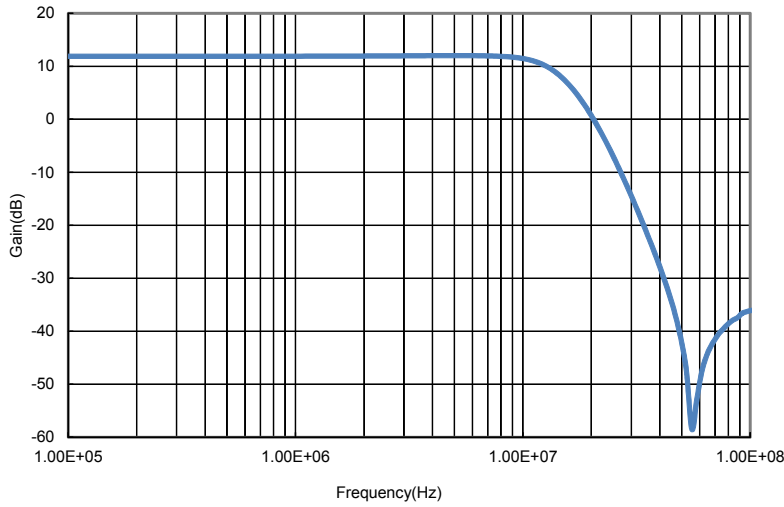

Figure 4: Not recommended 2-system drive circuit

■ TYPICAL CHARACTERISTICS

Gain vs Frequency



I_{cc} vs Supply Voltage

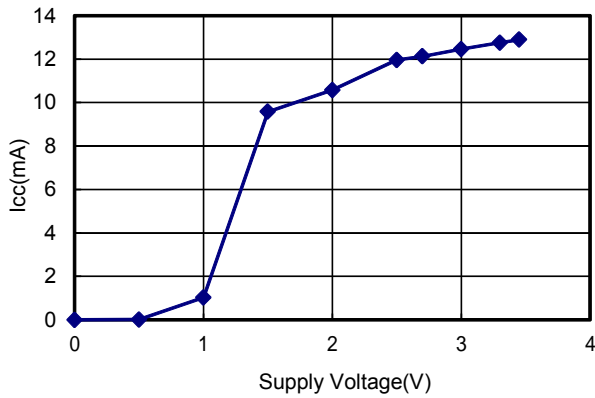

I_{save} vs Supply Voltage

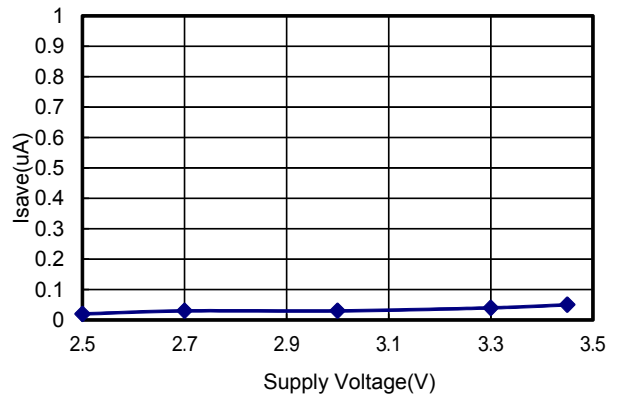

VOM vs Supply Voltage

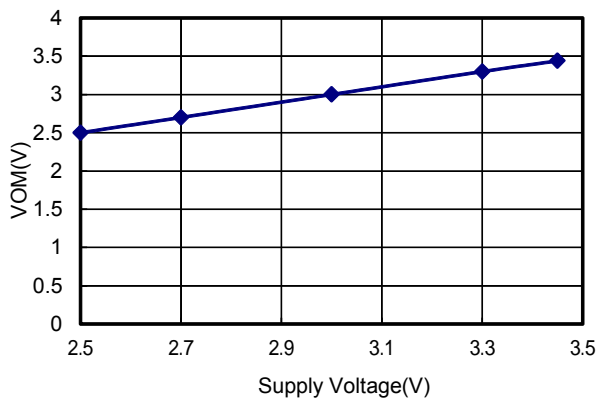

G_v vs Supply Voltage

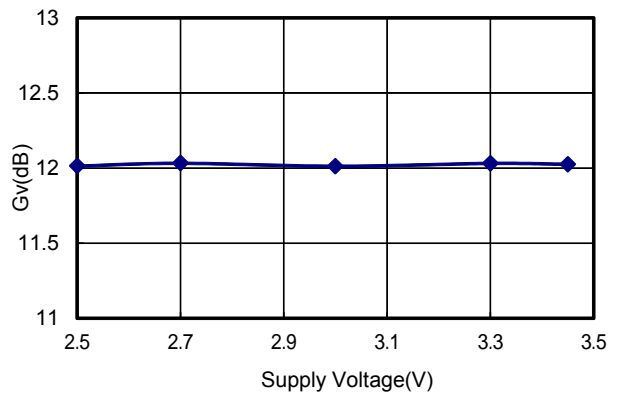

■ TYPICAL CHARACTERISTICS

Gf6.75MHz vs Supply Voltage

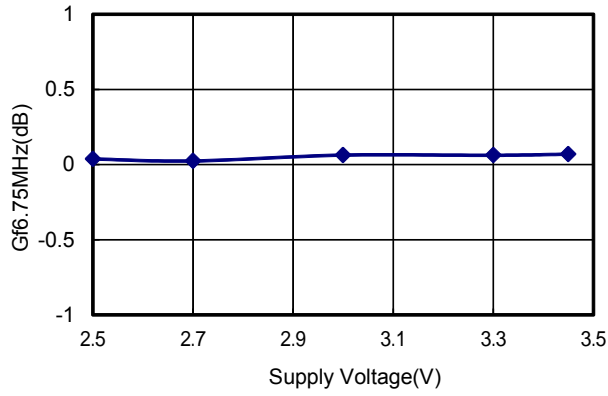

Gf54MHz vs Supply Voltage

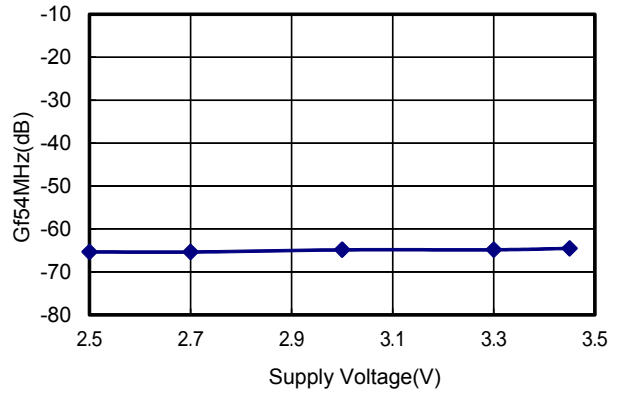

DG vs Supply Voltage

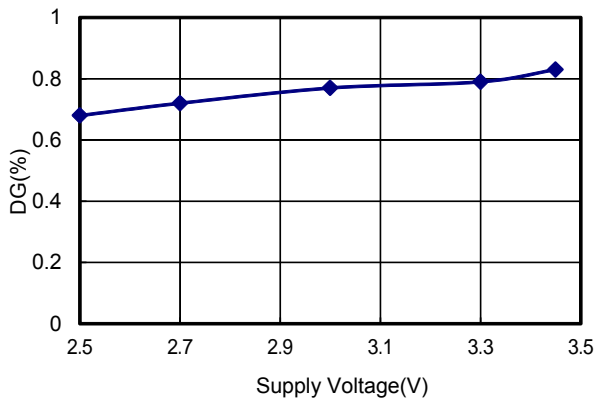

DP vs Supply Voltage

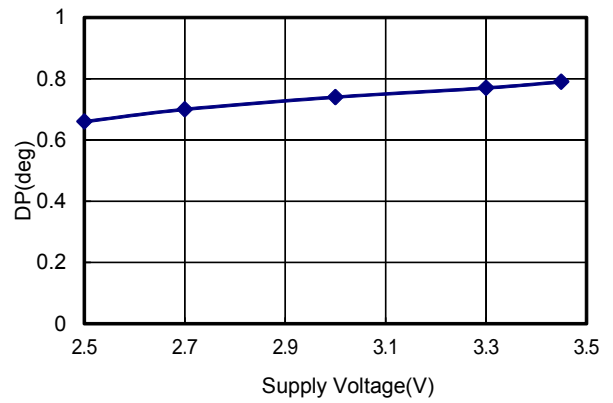

SN vs Supply Voltage

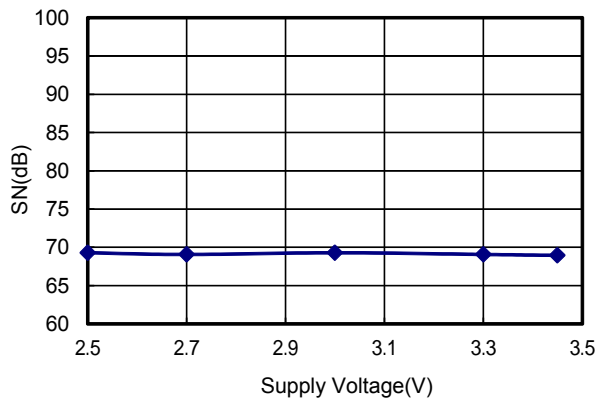

Nswpl vs Supply Voltage

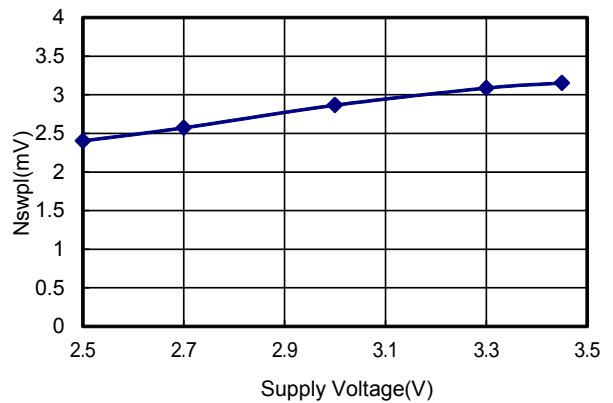

■ TYPICAL CHARACTERISTICS

VthH vs Supply Voltage

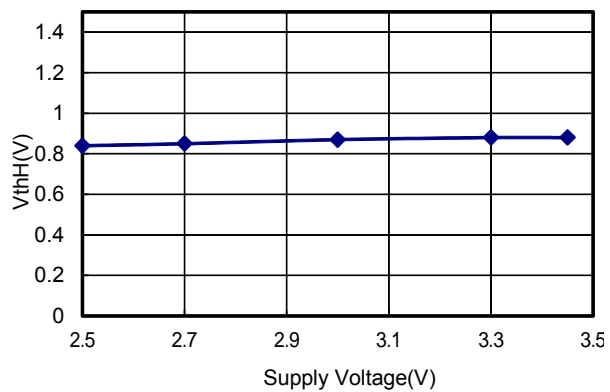

VthL vs Supply Voltage

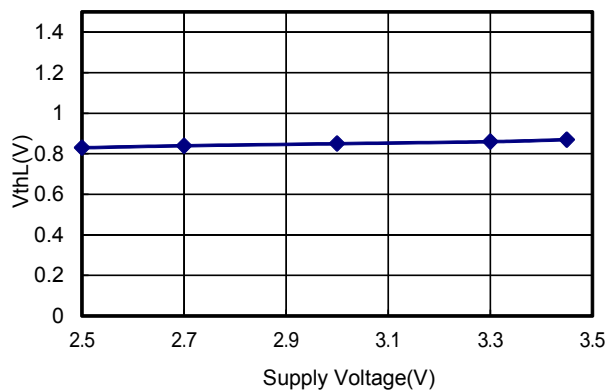

■ TYPICAL CHARACTERISTICS

Icc vs Temp

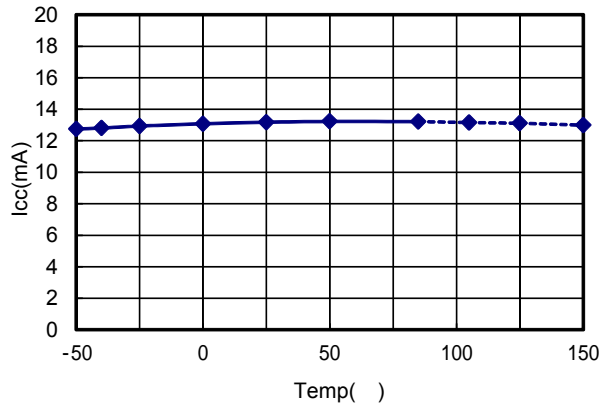

Isave vs Temp

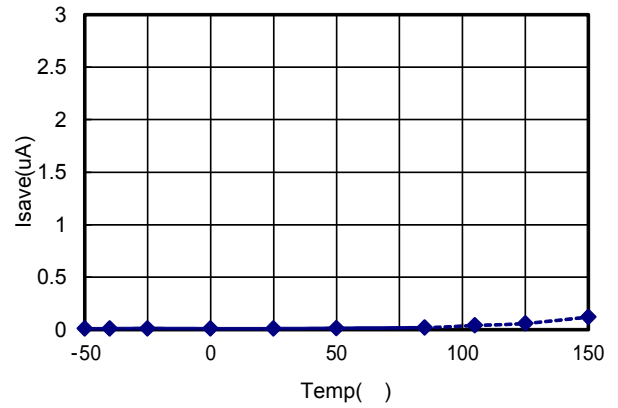

VOM vs Temp

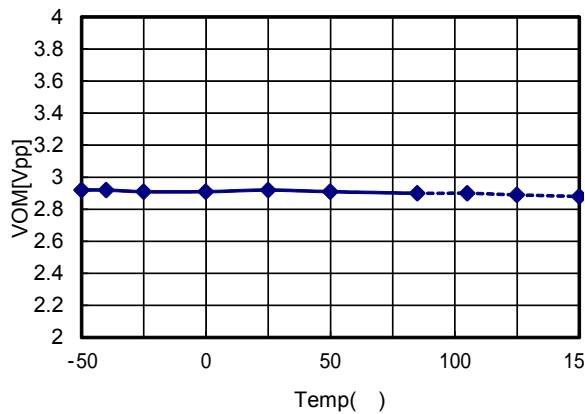

Gv vs Temp

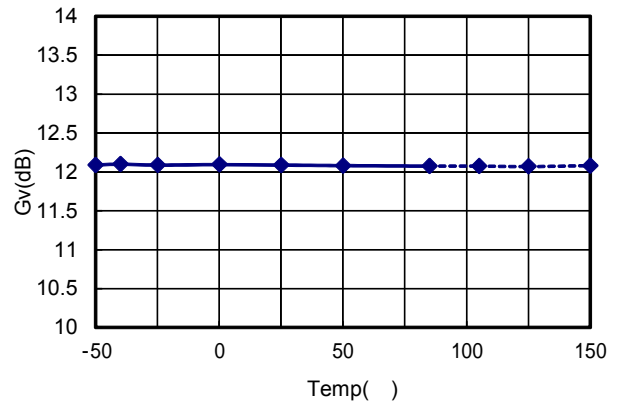

Gf6.75M vs Temp

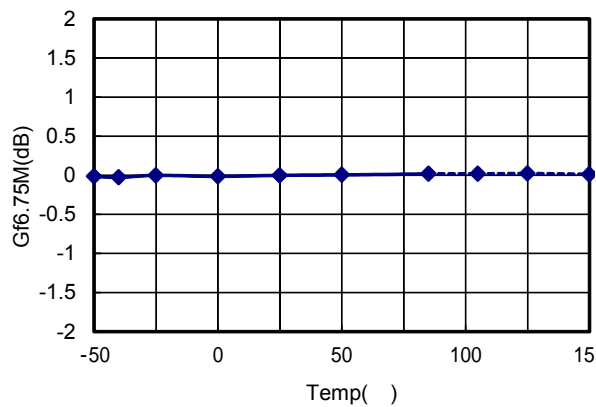

Gf54M vs Temp

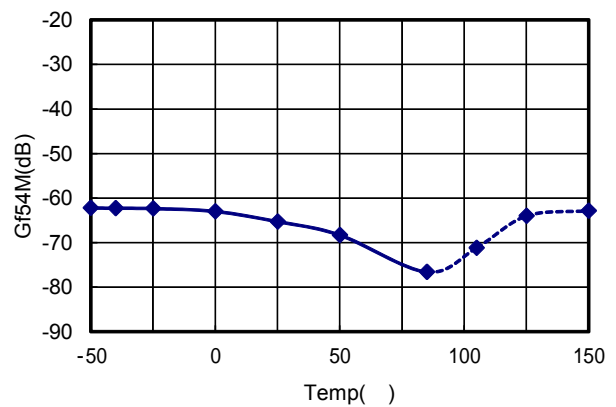

■ TYPICAL CHARACTERISTICS

DG vs Temp

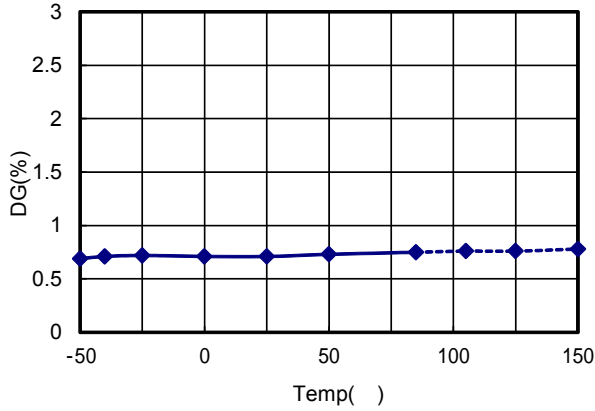

DP vs Temp

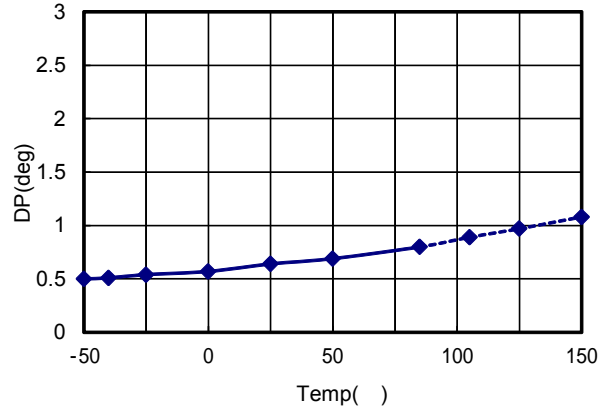

SN vs Temp

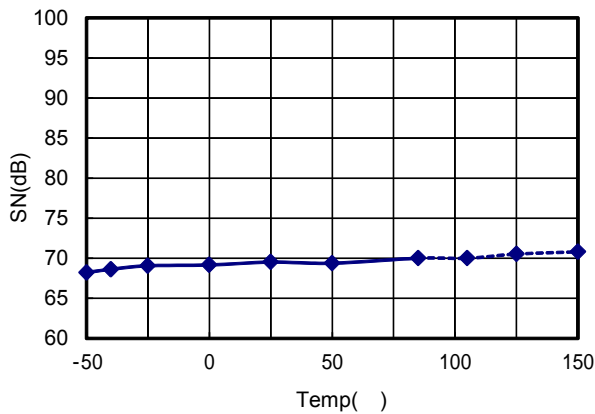

Nswpl vs Temp

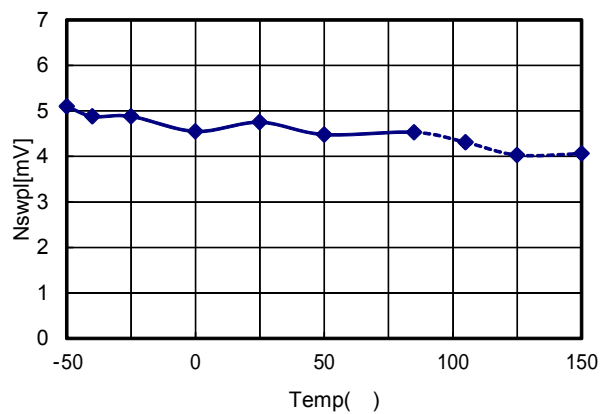

VthH vs Temp

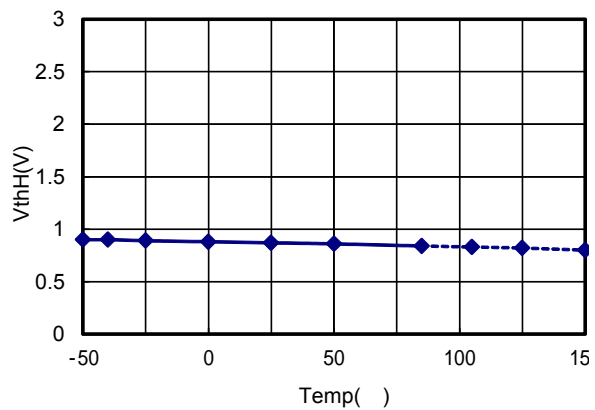

VthL vs Temp

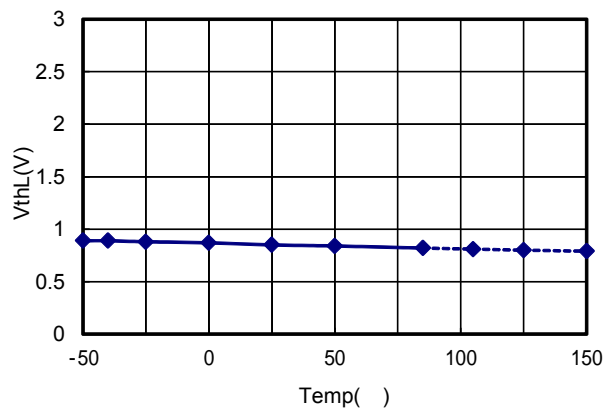

[CAUTION]

The specifications on this databook are only given for information, without any guarantee as regards either mistakes or omissions. The application circuits in this databook are described only to show representative usages of the product and not intended for the guarantee or permission of any right

Mouser Electronics

Authorized Distributor

Click to View Pricing, Inventory, Delivery & Lifecycle Information:

[NJR:](#)

[NJU71032RB1](#) [NJU71032RB1-TE2](#)

Данный компонент на территории Российской Федерации

Вы можете приобрести в компании MosChip.

Для оперативного оформления запроса Вам необходимо перейти по данной ссылке:

<http://moschip.ru/get-element>

Вы можете разместить у нас заказ для любого Вашего проекта, будь то серийное производство или разработка единичного прибора.

В нашем ассортименте представлены ведущие мировые производители активных и пассивных электронных компонентов.

Нашей специализацией является поставка электронной компонентной базы двойного назначения, продукции таких производителей как XILINX, Intel (ex.ALTERA), Vicor, Microchip, Texas Instruments, Analog Devices, Mini-Circuits, Amphenol, Glenair.

Сотрудничество с глобальными дистрибьюторами электронных компонентов, предоставляет возможность заказывать и получать с международных складов практически любой перечень компонентов в оптимальные для Вас сроки.

На всех этапах разработки и производства наши партнеры могут получить квалифицированную поддержку опытных инженеров.

Система менеджмента качества компании отвечает требованиям в соответствии с ГОСТ Р ИСО 9001, ГОСТ РВ 0015-002 и ЭС РД 009

Офис по работе с юридическими лицами:

105318, г.Москва, ул.Щербаковская д.3, офис 1107, 1118, ДЦ «Щербаковский»

Телефон: +7 495 668-12-70 (многоканальный)

Факс: +7 495 668-12-70 (доб.304)

E-mail: info@moschip.ru

Skype отдела продаж:

moschip.ru

moschip.ru_4

moschip.ru_6

moschip.ru_9