

D7E

Sealed Vibration Sensors and Tilt Sensor

Quickly Detect Vibration or Tilting to Help Prevent Secondary Disasters. Affordable Vibration/Tilt Sensors with Sealed Structure

- Sealing performance to IP67 degree of protection (switch section).
- Applicable to stoves, oil heaters, and other applications that require resistance to harsh environments.
- A Tilt Sensor is also provide in the lineup.

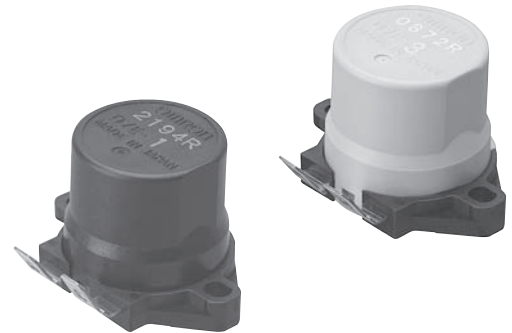

RoHS Compliant

Ordering Information

Type	Model
Vibration Sensors	D7E-1
	D7E-2
	D7E-5
Tilt Sensor	D7E-3

Performance

Item		Model Type	D7E-1	D7E-2	D7E-5	D7E-3
			Vibration Sensors			Tilt Sensor
Operating characteristic	Acceleration range		130 to 200 gals*	100 to 170 gals*	120 to 195 gals*	---
	Operating angle		---			50° to 80°
	Off time		50 ms min. (for periods of 0.3 s, 0.5 s, and 0.7 s at 200 gals for the D7E-1, 170 gals for the D7E-2, and 195 gals for the D7E-5)			---
Output	Contact form		SPST-NC			
	Electrical ratings		0.1mA at 5 VDC to 100mA at 30 VDC, resistive load			
	Contact resistance		Initial value: 100mΩ max.			
Basic specifications	Electrical life expectancy		5,000 operations (at 10 to 20 operations/min with resistive load of 100 mA at 30 VDC)			
	Degree of protection		IP67 (switch section)			
	Operating temperature		-25 to 60°C (with no icing or condensation)			
	Storage temperature		-25 to 60°C (with no icing or condensation)			-25 to 70°C (with no icing or condensation)
	Operating humidity		45% to 95%			
	Dielectric strength		250 VAC, 50/60 Hz for 1 min			

* These are the accelerations for operation at periods of 0.3 s, 0.5 s, and 0.7 s measured with the horizontal vibration method. Mounting standard: ±30' (±0.5°).

Note: Ask your OMRON representative for details.

■ Dimensions (Unit: mm)

D7E-□

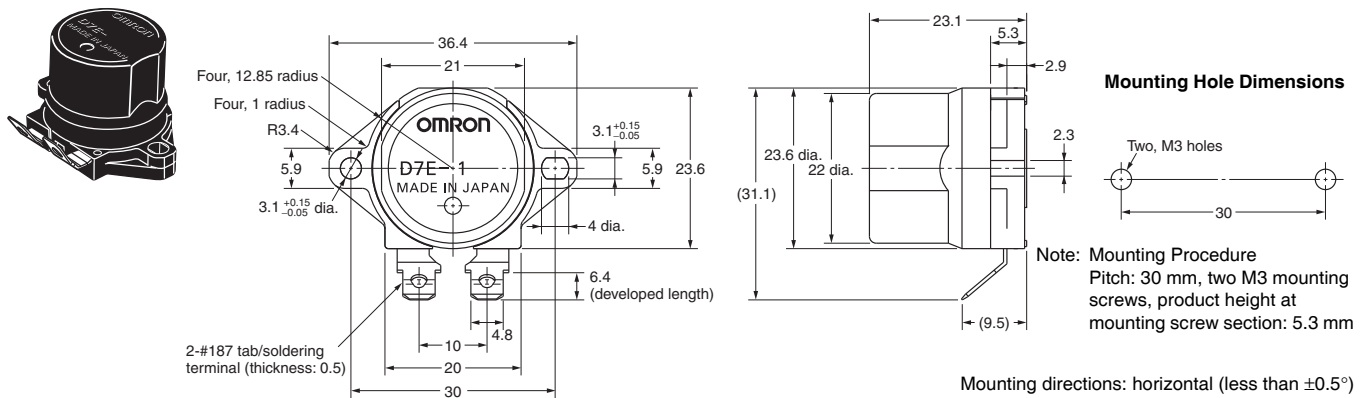

■ Safety Precautions

- If the mounting surface is not level, deformation from mounting may adversely affect operating characteristics.
Do not use a mounting surface with warpage of more than 0.3 mm. Use M3 mounting screws and tighten them to 0.39 to 0.59 N·m.
Use washers or other means to prevent loosening of the screws when mounting.
- Do not subject the Sensor to direct sunlight.
- Also, OMRON is not responsible for the deterioration of functions caused by washing with water, submersion in water, oil leaks, or contact with organic solvents.
- Do not use the Sensor in any location where vibration would adversely affect the operating acceleration or other mechanical characteristics (such as locations affected by opening and closing of doors, locations with passing vehicles, or other locations that are subject to vibration or shock from equipment or other sources).

Electronic and Mechanical Components Company

Regional Contact

Americas

<https://www.components.omron.com/>

Asia-Pacific

<https://ecb.omron.com.sg/>

Korea

<https://www.omron-ecb.co.kr/>

Europe

<http://components.omron.eu/>

China

<https://www.ecb.omron.com.cn/>

Japan

<https://www.omron.co.jp/ecb/>

Mouser Electronics

Authorized Distributor

Click to View Pricing, Inventory, Delivery & Lifecycle Information:

[Omron:](#)

[D7E-3](#)

Данный компонент на территории Российской Федерации

Вы можете приобрести в компании MosChip.

Для оперативного оформления запроса Вам необходимо перейти по данной ссылке:

<http://moschip.ru/get-element>

Вы можете разместить у нас заказ для любого Вашего проекта, будь то серийное производство или разработка единичного прибора.

В нашем ассортименте представлены ведущие мировые производители активных и пассивных электронных компонентов.

Нашей специализацией является поставка электронной компонентной базы двойного назначения, продукции таких производителей как XILINX, Intel (ex.ALTERA), Vicor, Microchip, Texas Instruments, Analog Devices, Mini-Circuits, Amphenol, Glenair.

Сотрудничество с глобальными дистрибьюторами электронных компонентов, предоставляет возможность заказывать и получать с международных складов практически любой перечень компонентов в оптимальные для Вас сроки.

На всех этапах разработки и производства наши партнеры могут получить квалифицированную поддержку опытных инженеров.

Система менеджмента качества компании отвечает требованиям в соответствии с ГОСТ Р ИСО 9001, ГОСТ РВ 0015-002 и ЭС РД 009

Офис по работе с юридическими лицами:

105318, г.Москва, ул.Щербаковская д.3, офис 1107, 1118, ДЦ «Щербаковский»

Телефон: +7 495 668-12-70 (многоканальный)

Факс: +7 495 668-12-70 (доб.304)

E-mail: info@moschip.ru

Skype отдела продаж:

moschip.ru

moschip.ru_4

moschip.ru_6

moschip.ru_9