

The S-57M1 Series, developed by CMOS technology, is a high-accuracy Hall IC that operates with a high-sensitivity, a high-speed detection and low current consumption.

The output voltage changes when the S-57M1 Series detects the intensity level of magnetic flux density and a polarity change. Using the S-57M1 Series with a magnet makes it possible to detect the rotation status in various devices.

High-density mounting is possible by using the small SOT-23-3 package.

Due to its high-accuracy magnetic characteristics, the S-57M1 Series can make operation's dispersion in the system combined with magnet smaller.

**Caution** This product is intended to use in general electronic devices such as consumer electronics, office equipment, and communications devices. Before using the product in medical equipment or automobile equipment including car audio, keyless entry and engine control unit, contact to ABLIC Inc. is indispensable.

## ■ Features

- |   |   |
|---|---|
| • Pole detection:                                 | Bipolar latch   |
| • Detection logic for magnetism <sup>*1</sup> :   | $V_{OUT} = "L"$ at S pole detection                   |
|   | $V_{OUT} = "H"$ at N pole detection                   |
| • Output form <sup>*1</sup> :                     | Nch open-drain output, CMOS output                    |
| • Magnetic sensitivity:                           | $B_{OP} = 3.0 \text{ mT typ.}$                        |
| • Operation cycle (current consumption):          | $t_{CYCLE} = 50 \mu\text{s (1400 } \mu\text{A) typ.}$ |
| • Power supply voltage range:                     | $V_{DD} = 2.7 \text{ V to } 5.5 \text{ V}$            |
| • Operation temperature range:                    | $T_a = -40^\circ\text{C to } +125^\circ\text{C}$      |
| • Lead-free (Sn 100%), halogen-free <sup>*2</sup> |   |

\*1. The option can be selected.

\*2. Refer to "■ Product Name Structure" for details.

## ■ Applications

- Motor
- Housing equipment
- Industrial equipment

## ■ Package

- SOT-23-3

■ Block Diagrams

1. Nch open-drain output product

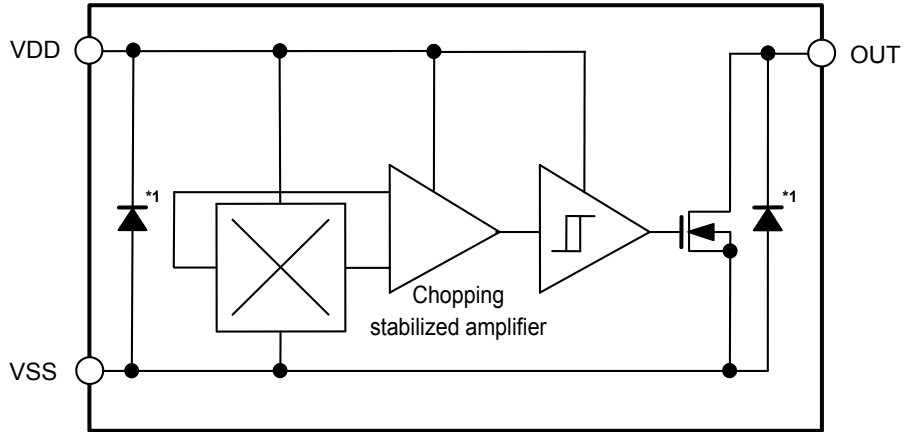

\*1. Parasitic diode

Figure 1

2. CMOS output product

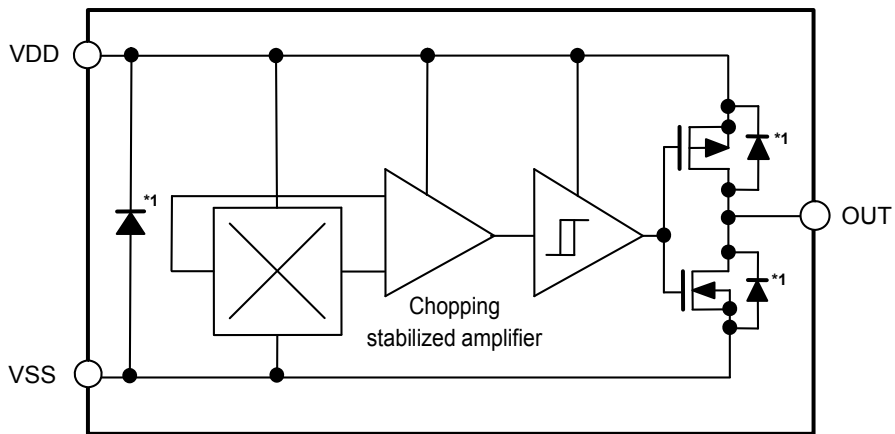

\*1. Parasitic diode

Figure 2

■ Product Name Structure

1. Product name

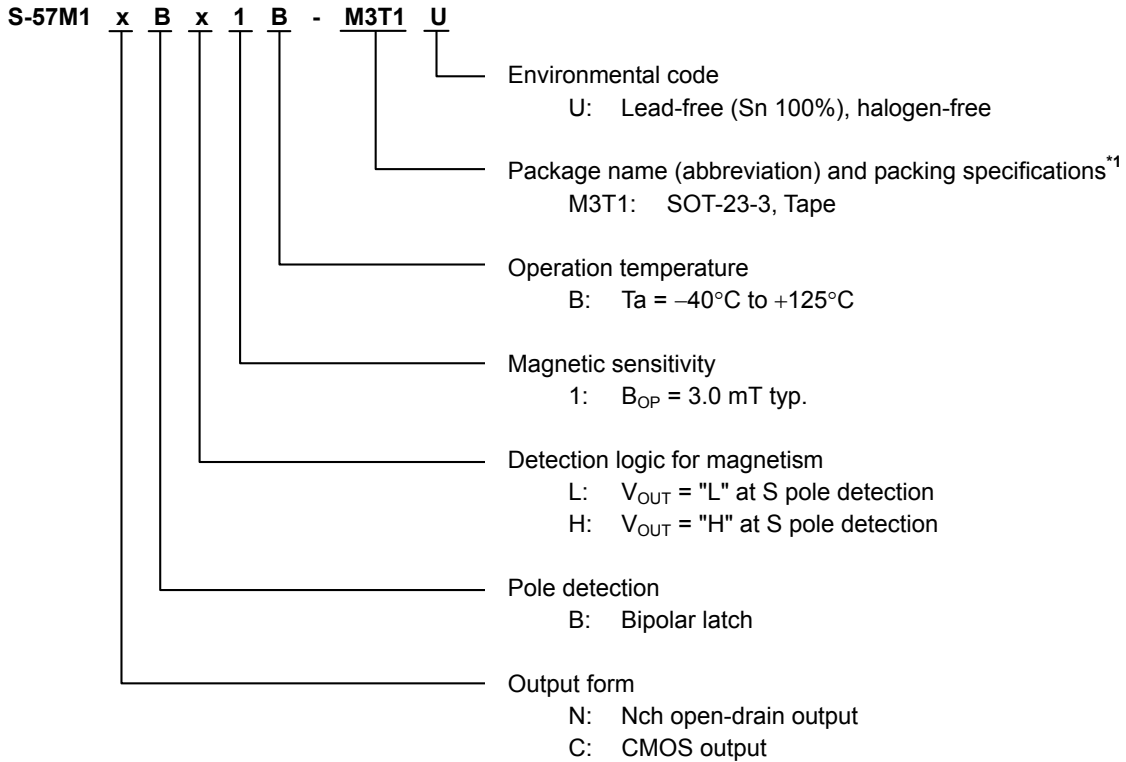

\*1. Refer to the tape drawing.

2. Package

Table 1 Package Drawing Codes

Package Name	Dimension	Tape	Reel
SOT-23-3	MP003-C-P-SD	MP003-C-C-SD	MP003-Z-R-SD

3. Product name list

Table 2

Product Name	Output Form	Pole Detection	Detection Logic for Magnetism	Magnetic Sensitivity ( $B_{OP}$ )
S-57M1NBL1B-M3T1U	Nch open-drain output	Bipolar latch	$V_{OUT} = "L"$ at S pole detection	3.0 mT typ.
S-57M1NBH1B-M3T1U	Nch open-drain output	Bipolar latch	$V_{OUT} = "H"$ at S pole detection	3.0 mT typ.
S-57M1CBH1B-M3T1U	CMOS output	Bipolar latch	$V_{OUT} = "H"$ at S pole detection	3.0 mT typ.

Remark Please contact our sales office for products other than the above.

■ **Pin Configuration**

1. SOT-23-3

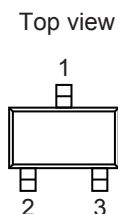

Figure 3

Table 3

Pin No.	Symbol	Description
1	VSS	GND pin
2	VDD	Power supply pin
3	OUT	Output pin

■ **Absolute Maximum Ratings**

Table 4

(Ta = +25°C unless otherwise specified)

Item	Symbol	Absolute Maximum Rating	Unit
Power supply voltage	$V_{DD}$	$V_{SS} - 0.3$ to $V_{SS} + 7.0$	V
Output current	$I_{OUT}$	$\pm 2.0$	mA
Output voltage	Nch open-drain output product	$V_{SS} - 0.3$ to $V_{SS} + 7.0$	V
	CMOS output product	$V_{SS} - 0.3$ to $V_{DD} + 0.3$	V
Power dissipation	$P_D$	$430^{*1}$	mW
Operation ambient temperature	$T_{opr}$	-40 to +125	°C
Storage temperature	$T_{stg}$	-40 to +150	°C

\*1. When mounted on board

[Mounted board]

(1) Board size: 114.3 mm × 76.2 mm × t1.6 mm

(2) Name: JEDEC STANDARD51-7

**Caution** The absolute maximum ratings are rated values exceeding which the product could suffer physical damage. These values must therefore not be exceeded under any conditions.

■ **Electrical Characteristics**

**Table 5**

(Ta = +25°C, V<sub>DD</sub> = 5.0 V, V<sub>SS</sub> = 0 V unless otherwise specified)

Item	Symbol	Condition		Min.	Typ.	Max.	Unit	Test Circuit
Power supply voltage	V <sub>DD</sub>	-		2.7	5.0	5.5	V	-
Current consumption	I <sub>DD</sub>	Average value		-	1400	2000	μA	1
Output voltage	V <sub>OUT</sub>	Nch open-drain output product	Output transistor Nch, I <sub>OUT</sub> = 2 mA	-	-	0.4	V	2
		CMOS output product	Output transistor Nch, I <sub>OUT</sub> = 2 mA	-	-	0.4	V	2
			Output transistor Pch, I <sub>OUT</sub> = -2 mA	V <sub>DD</sub> - 0.4	-	-	V	3
Leakage current	I <sub>LEAK</sub>	Nch open-drain output product Output transistor Nch, V <sub>OUT</sub> = 5.5 V		-	-	1	μA	4
Operation cycle	t <sub>CYCLE</sub>	-		-	50	100	μs	-

■ **Magnetic Characteristics**

**Table 6**

(Ta = +25°C, V<sub>DD</sub> = 5.0 V, V<sub>SS</sub> = 0 V unless otherwise specified)

Item	Symbol	Condition	Min.	Typ.	Max.	Unit	Test Circuit
Operation point*1	S pole	B <sub>OP</sub>	-	1.4	3.0	4.0	mT
Release point*2	N pole	B <sub>RP</sub>	-	-4.0	-3.0	-1.4	mT
Hysteresis width*3	B <sub>HYS</sub>	B <sub>HYS</sub> = B <sub>OP</sub> - B <sub>RP</sub>	-	6.0	-	mT	5

\*1. B<sub>OP</sub>: Operation point

B<sub>OP</sub> is the value of magnetic flux density when the output voltage (V<sub>OUT</sub>) changes after the magnetic flux density applied to the S-57M1 Series by the magnet (S pole) is increased (by moving the magnet closer).

V<sub>OUT</sub> retains the status until a magnetic flux density of the N pole higher than B<sub>RP</sub> is applied.

\*2. B<sub>RP</sub>: Release point

B<sub>RP</sub> is the value of magnetic flux density when the output voltage (V<sub>OUT</sub>) changes after the magnetic flux density applied to the S-57M1 Series by the magnet (N pole) is increased (by moving the magnet closer).

V<sub>OUT</sub> retains the status until a magnetic flux density of the S pole higher than B<sub>OP</sub> is applied.

\*3. B<sub>HYS</sub>: Hysteresis width

B<sub>HYS</sub> is the difference of magnetic flux density between B<sub>OP</sub> and B<sub>RP</sub>.

**Remark** The unit of magnetic density mT can be converted by using the formula 1 mT = 10 Gauss.

■ Test Circuits

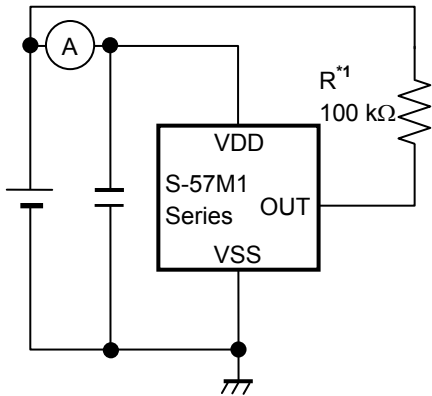

\*1. Resistor (R) is unnecessary for the CMOS output product.

Figure 4 Test Circuit 1

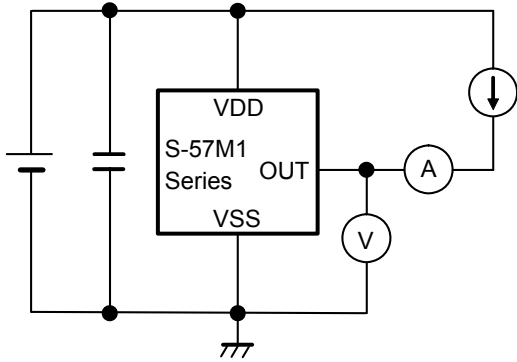

Figure 5 Test Circuit 2

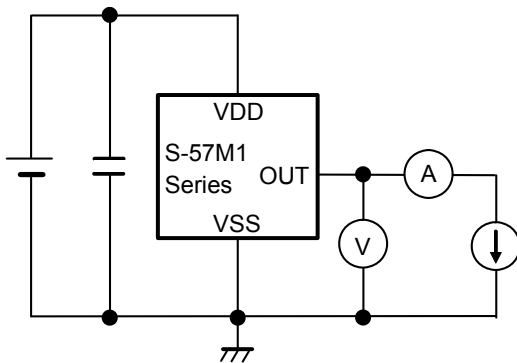

Figure 6 Test Circuit 3

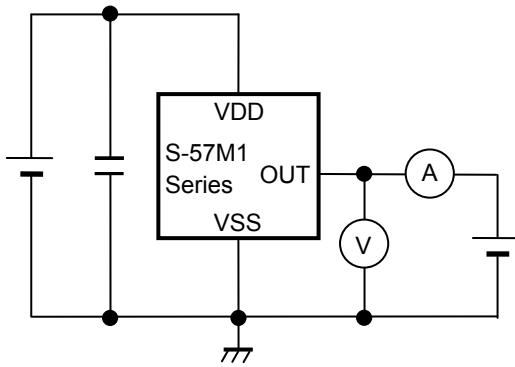
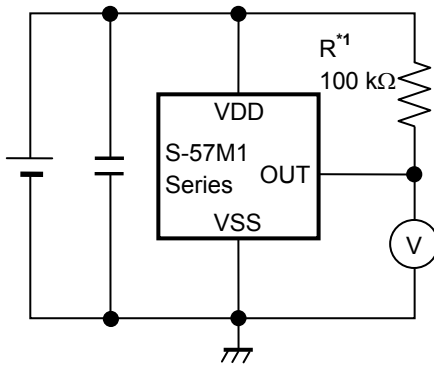

Figure 7 Test Circuit 4



\*1. Resistor (R) is unnecessary for the CMOS output product.

Figure 8 Test Circuit 5

■ Standard Circuit

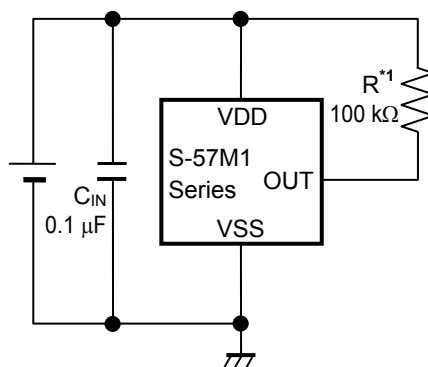

\*1. Resistor (R) is unnecessary for the CMOS output product.

Figure 9

**Caution** The above connection diagram and constant will not guarantee successful operation. Perform a thorough evaluation using the actual application to set the constant.



■ Operation

1. Direction of applied magnetic flux

The S-57M1 Series detects the magnetic flux density which is vertical to the marking surface.  
Figure 10 shows the direction in which magnetic flux is being applied.

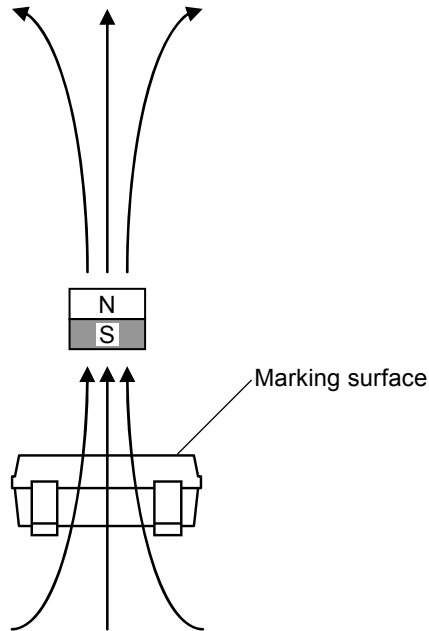

Figure 10

2. Position of Hall sensor

Figure 11 shows the position of Hall sensor.

The center of this Hall sensor is located in the area indicated by a circle, which is in the center of a package as described below.

The following also shows the distance (typ. value) between the marking surface and the chip surface of a package.

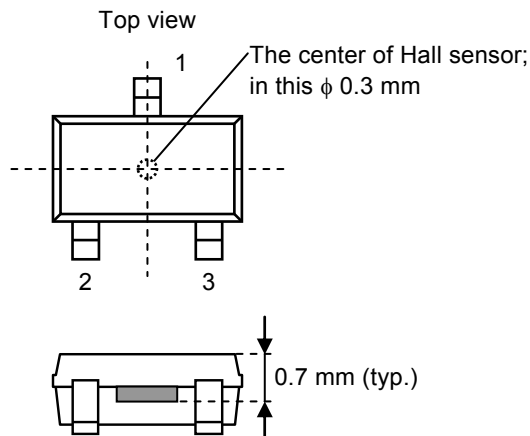

Figure 11

**3. Basic operation**

The S-57M1 Series changes the output voltage ( $V_{OUT}$ ) according to the level of the magnetic flux density and a polarity change (N pole or S pole) applied by a magnet. Definition of the magnetic field is performed every operation cycle indicated in "■ Electrical Characteristics".

**3.1 Product with  $V_{OUT} = "L"$  at S pole detection**

When the magnetic flux density of the S pole perpendicular to the marking surface exceeds the operation point ( $B_{OP}$ ) after the S pole of a magnet is moved closer to the marking surface of the S-57M1 Series,  $V_{OUT}$  changes from "H" to "L". When the N pole of a magnet is moved closer to the marking surface of the S-57M1 Series and the magnetic flux density of the N pole is higher than the release point ( $B_{RP}$ ),  $V_{OUT}$  changes from "L" to "H". In case of  $B_{RP} < B < B_{OP}$ ,  $V_{OUT}$  retains the status.

Figure 12 shows the relationship between the magnetic flux density and  $V_{OUT}$ .

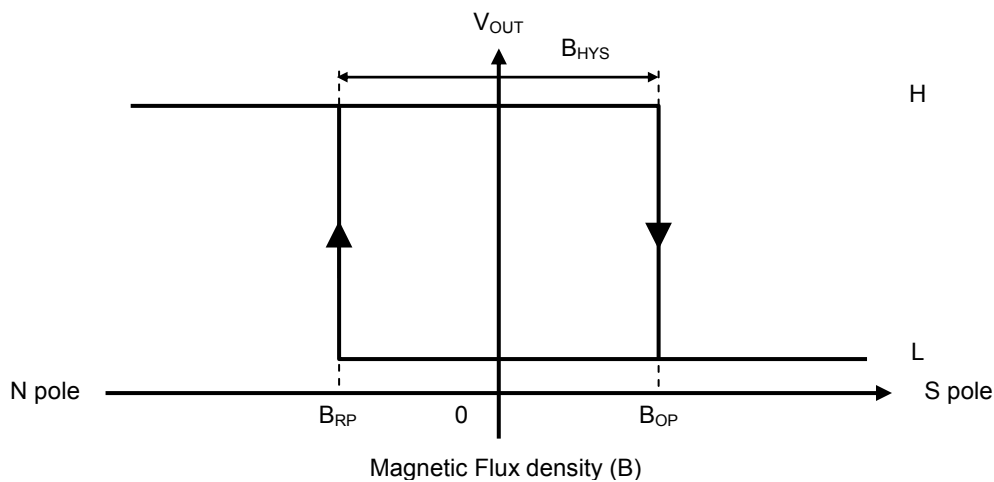
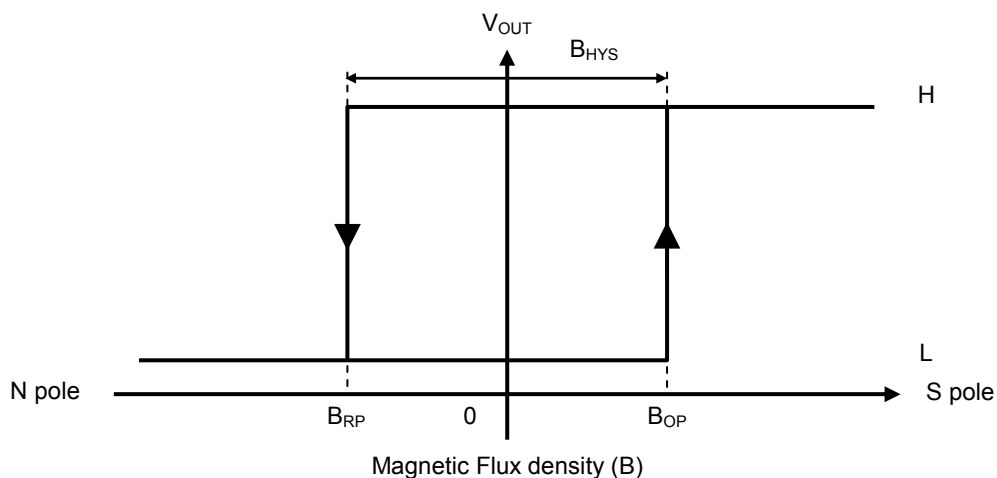

**Figure 12**

**3.2 Product with  $V_{OUT} = "H"$  at S pole detection**

When the magnetic flux density of the S pole perpendicular to the marking surface exceeds  $B_{OP}$  after the S pole of a magnet is moved closer to the marking surface of the S-57M1 Series,  $V_{OUT}$  changes from "L" to "H". When the N pole of a magnet is moved closer to the marking surface of the S-57M1 Series and the magnetic flux density of the N pole is higher than  $B_{RP}$ ,  $V_{OUT}$  changes from "H" to "L". In case of  $B_{RP} < B < B_{OP}$ ,  $V_{OUT}$  retains the status.

Figure 13 shows the relationship between the magnetic flux density and  $V_{OUT}$ .



**Figure 13**

**■ Precautions**

- If the impedance of the power supply is high, the IC may malfunction due to a supply voltage drop caused by feed-through current. Take care with the pattern wiring to ensure that the impedance of the power supply is low.
- Note that the IC may malfunction if the power supply voltage rapidly changes.
- Do not apply an electrostatic discharge to this IC that exceeds the performance ratings of the built-in electrostatic protection circuit.
- Large stress on this IC may affect on the magnetic characteristics. Avoid large stress which is caused by bend and distortion during mounting the IC on a board or handle after mounting.
- ABLIC Inc. claims no responsibility for any disputes arising out of or in connection with any infringement by products including this IC of patents owned by a third party.

■ **Marking Specification**

1. **SOT-23-3**

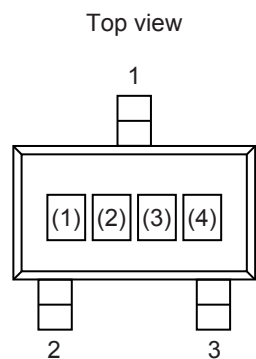

(1) to (3): Product code (Refer to **Product name vs. Product code.**)  
 (4): Lot number

**Product name vs. Product code**

Product Name	Product Code		
	(1)	(2)	(3)
S-57M1NBL1B-M3T1U	W	7	A
S-57M1NBH1B-M3T1U	W	7	B
S-57M1CBH1B-M3T1U	W	7	C

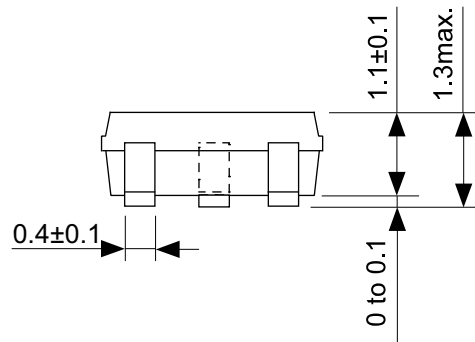
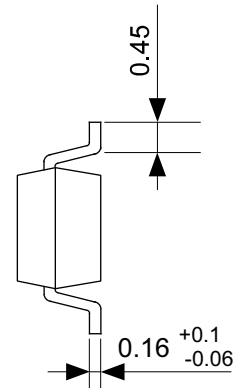
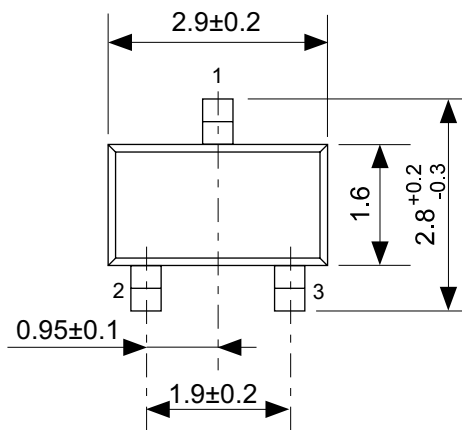

No. MP003-C-P-SD-1.1

TITLE	SOT233-C-PKG Dimensions
No.	MP003-C-P-SD-1.1
ANGLE	
UNIT	mm
<b>ABLIC Inc.</b>	

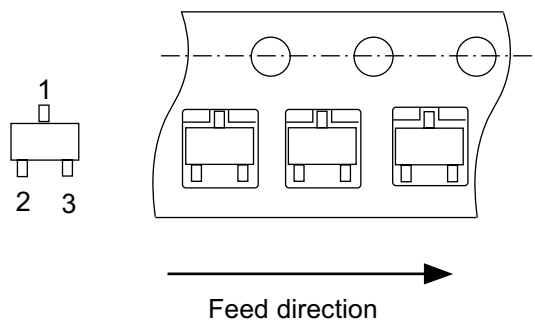
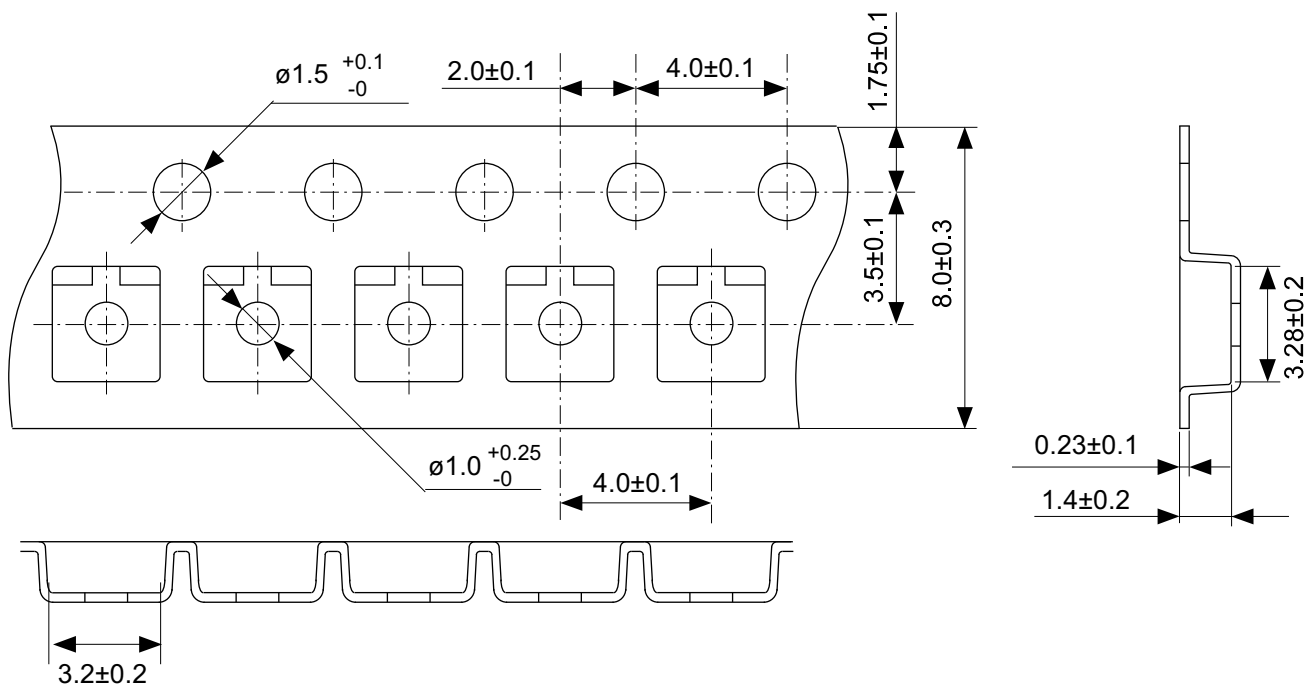

No. MP003-C-C-SD-2.0

TITLE	SOT233-C-Carrier Tape
No.	MP003-C-C-SD-2.0
ANGLE	
UNIT	mm
<b>ABLIC Inc.</b>	

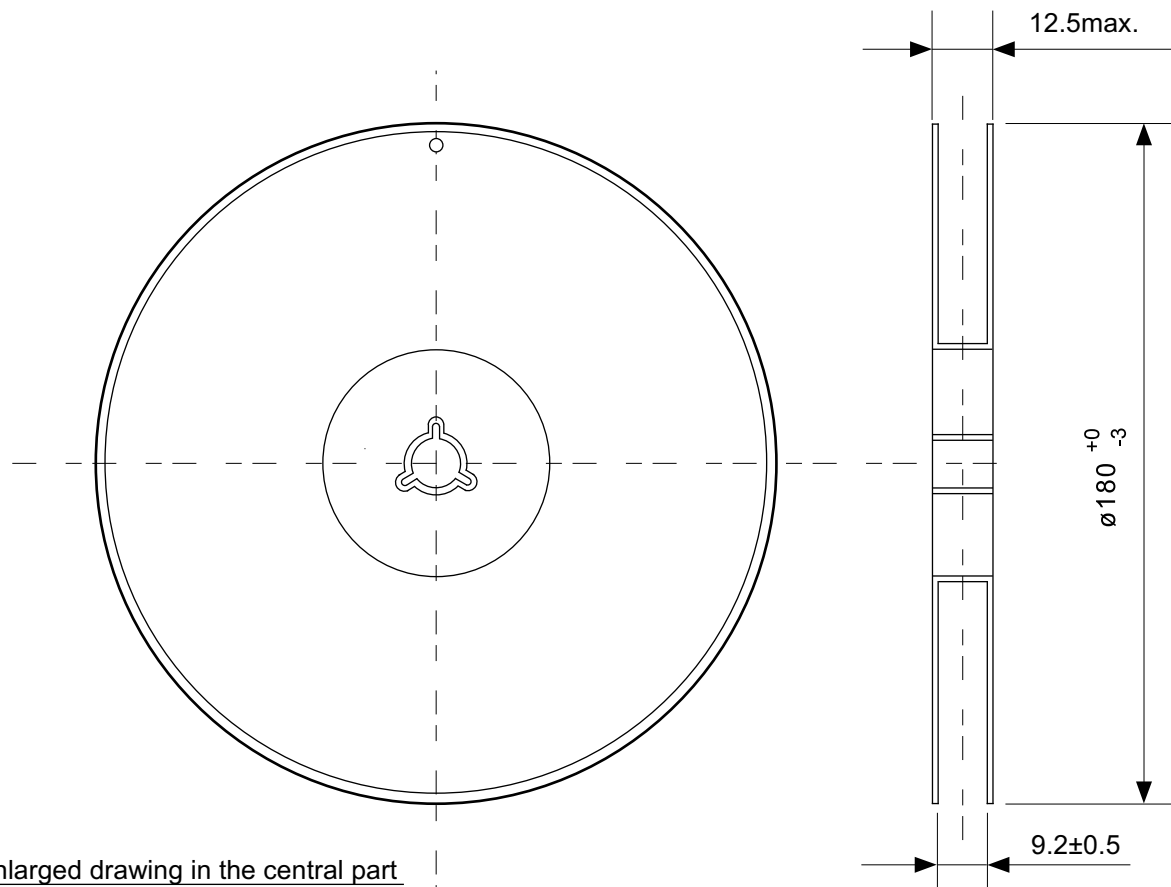

Enlarged drawing in the central part

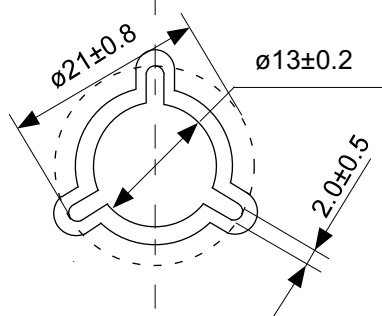

No. MP003-Z-R-SD-1.0

TITLE	SOT233-C-Reel		
No.	MP003-Z-R-SD-1.0		
ANGLE		QTY.	3,000
UNIT	mm		
<b>ABLIC Inc.</b>			

## Disclaimers (Handling Precautions)

1. All the information described herein (product data, specifications, figures, tables, programs, algorithms and application circuit examples, etc.) is current as of publishing date of this document and is subject to change without notice.
2. The circuit examples and the usages described herein are for reference only, and do not guarantee the success of any specific mass-production design.  
ABLIC Inc. is not liable for any losses, damages, claims or demands caused by the reasons other than the products described herein (hereinafter "the products") or infringement of third-party intellectual property right and any other right due to the use of the information described herein.
3. ABLIC Inc. is not liable for any losses, damages, claims or demands caused by the incorrect information described herein.
4. Be careful to use the products within their ranges described herein. Pay special attention for use to the absolute maximum ratings, operation voltage range and electrical characteristics, etc.  
ABLIC Inc. is not liable for any losses, damages, claims or demands caused by failures and / or accidents, etc. due to the use of the products outside their specified ranges.
5. Before using the products, confirm their applications, and the laws and regulations of the region or country where they are used and verify suitability, safety and other factors for the intended use.
6. When exporting the products, comply with the Foreign Exchange and Foreign Trade Act and all other export-related laws, and follow the required procedures.
7. The products are strictly prohibited from using, providing or exporting for the purposes of the development of weapons of mass destruction or military use. ABLIC Inc. is not liable for any losses, damages, claims or demands caused by any provision or export to the person or entity who intends to develop, manufacture, use or store nuclear, biological or chemical weapons or missiles, or use any other military purposes.
8. The products are not designed to be used as part of any device or equipment that may affect the human body, human life, or assets (such as medical equipment, disaster prevention systems, security systems, combustion control systems, infrastructure control systems, vehicle equipment, traffic systems, in-vehicle equipment, aviation equipment, aerospace equipment, and nuclear-related equipment), excluding when specified for in-vehicle use or other uses by ABLIC, Inc. Do not apply the products to the above listed devices and equipments.  
ABLIC Inc. is not liable for any losses, damages, claims or demands caused by unauthorized or unspecified use of the products.
9. In general, semiconductor products may fail or malfunction with some probability. The user of the products should therefore take responsibility to give thorough consideration to safety design including redundancy, fire spread prevention measures, and malfunction prevention to prevent accidents causing injury or death, fires and social damage, etc. that may ensue from the products' failure or malfunction.  
The entire system in which the products are used must be sufficiently evaluated and judged whether the products are allowed to apply for the system on customer's own responsibility.
10. The products are not designed to be radiation-proof. The necessary radiation measures should be taken in the product design by the customer depending on the intended use.
11. The products do not affect human health under normal use. However, they contain chemical substances and heavy metals and should therefore not be put in the mouth. The fracture surfaces of wafers and chips may be sharp. Be careful when handling these with the bare hands to prevent injuries, etc.
12. When disposing of the products, comply with the laws and ordinances of the country or region where they are used.
13. The information described herein contains copyright information and know-how of ABLIC Inc. The information described herein does not convey any license under any intellectual property rights or any other rights belonging to ABLIC Inc. or a third party. Reproduction or copying of the information from this document or any part of this document described herein for the purpose of disclosing it to a third-party is strictly prohibited without the express permission of ABLIC Inc.
14. For more details on the information described herein or any other questions, please contact ABLIC Inc.'s sales representative.
15. This Disclaimers have been delivered in a text using the Japanese language, which text, despite any translations into the English language and the Chinese language, shall be controlling.

2.4-2019.07



# Mouser Electronics

Authorized Distributor

Click to View Pricing, Inventory, Delivery & Lifecycle Information:

[ABLIC:](#)

[S-57M1CBH1B-M3T1U](#) [S-57M1NBH1B-M3T1U](#) [S-57M1NBL1B-M3T1U](#)

## Данный компонент на территории Российской Федерации

### Вы можете приобрести в компании MosChip.

Для оперативного оформления запроса Вам необходимо перейти по данной ссылке:

<http://moschip.ru/get-element>

Вы можете разместить у нас заказ для любого Вашего проекта, будь то серийное производство или разработка единичного прибора.

В нашем ассортименте представлены ведущие мировые производители активных и пассивных электронных компонентов.

Нашей специализацией является поставка электронной компонентной базы двойного назначения, продукции таких производителей как XILINX, Intel (ex.ALTERA), Vicor, Microchip, Texas Instruments, Analog Devices, Mini-Circuits, Amphenol, Glenair.

Сотрудничество с глобальными дистрибьюторами электронных компонентов, предоставляет возможность заказывать и получать с международных складов практически любой перечень компонентов в оптимальные для Вас сроки.

На всех этапах разработки и производства наши партнеры могут получить квалифицированную поддержку опытных инженеров.

Система менеджмента качества компании отвечает требованиям в соответствии с ГОСТ Р ИСО 9001, ГОСТ РВ 0015-002 и ЭС РД 009

### Офис по работе с юридическими лицами:

105318, г.Москва, ул.Щербаковская д.3, офис 1107, 1118, ДЦ «Щербаковский»

Телефон: +7 495 668-12-70 (многоканальный)

Факс: +7 495 668-12-70 (доб.304)

E-mail: [info@moschip.ru](mailto:info@moschip.ru)

Skype отдела продаж:

moschip.ru

moschip.ru\_4

moschip.ru\_6

moschip.ru\_9