

## 1. General description

---

The PCF2119x is a low power CMOS<sup>1</sup> LCD controller and driver, designed to drive a dot matrix LCD display of 2-lines by 16 characters or 1-line by 32 characters with 5 × 8 dot format. All necessary functions for the display are provided in a single chip, including on-chip generation of LCD bias voltages, resulting in a minimum of external components and lower system current consumption. The PCF2119x interfaces to most microcontrollers via a 4-bit or 8-bit bus or via the 2-wire I<sup>2</sup>C-bus. The chip contains a character generator and displays alphanumeric and kana (Japanese) characters.

The letter 'x' in PCF2119x characterizes the built-in character set. Various character sets can be manufactured on request. In addition 16 user defined symbols (5 × 8 dot format) are available.

For a selection of NXP LCD character drivers, see [Table 51 on page 78](#).

## 2. Features and benefits

---

- Single-chip LCD controller and driver
- 2-line display of up to 16 characters plus 160 icons or 1-line display of up to 32 characters plus 160 icons
- 5 × 7 character format plus cursor; 5 × 8 for kana (Japanese) and user defined symbols
- Reduced current consumption while displaying icons only
- Icon blink function
- On-chip:
  - ◆ Configurable 4, 3, or 2 times voltage multiplier generating LCD supply voltage, independent of V<sub>DD</sub>, programmable by instruction (external supply also possible)
  - ◆ Temperature compensation of on-chip generated V<sub>LCDOUT</sub>: -0.16 %/K to -0.24 %/K (programmable by instruction)
  - ◆ Generation of intermediate LCD bias voltages
  - ◆ Oscillator requires no external components (external clock also possible)
- Display Data RAM (DDRAM): 80 characters
- Character Generator ROM (CGROM): 240 characters (5 × 8)
- Character Generator RAM (CGRAM): 16 characters (5 × 8); 4 characters used to drive 160 icons, 8 characters used if icon blink feature is used in application
- 4-bit or 8-bit parallel bus and 2-wire I<sup>2</sup>C-bus interface
- Manufactured in silicon gate CMOS process
- 18 row and 80 column outputs

---

1. The definition of the abbreviations and acronyms used in this data sheet can be found in [Section 21](#).

- Multiplex rates 1:18 (2-line display or 1-line display), 1:9 (for 1-line display of up to 16 characters and 80 icons) and 1:2 (for icon only mode)
- Uses common 11 code instruction set (extended)
- Logic supply voltage:  $V_{DD1} - V_{SS1} = 1.5 \text{ V to } 5.5 \text{ V}$  (chip may be driven with two battery cells)
- LCD supply voltage:  $V_{LCDOUT} - V_{SS2} = 2.2 \text{ V to } 6.5 \text{ V}$
- $V_{LCD}$  generator supply voltage:  $V_{DD2} - V_{SS2} = 2.2 \text{ V to } 4 \text{ V}$  and  $V_{DD3} - V_{SS2} = 2.2 \text{ V to } 4 \text{ V}$
- Direct mode to save current consumption for icon mode and multiplex drive mode 1:9 (depending on  $V_{DD2}$  value and LCD liquid properties)
- Very low current consumption (20  $\mu\text{A}$  to 200  $\mu\text{A}$ ):
  - ◆ Icon mode: < 25  $\mu\text{A}$
  - ◆ Power-down mode: < 2  $\mu\text{A}$
- Icon mode is used to save current. When only icons are displayed, a much lower LCD operating voltage can be used and the switching frequency of the LCD outputs is reduced; in most applications it is possible to use  $V_{DD}$  as LCD supply voltage

### 3. Applications

---

- Telecom equipment
- Portable instruments
- Point-of-sale terminals

## 4. Ordering information

Table 1. Ordering information

Type number	Package		
	Name	Description	Version
PCF2119AU	bare die	168 bumps	PCF2119x
PCF2119DU	bare die	168 bumps	PCF2119x
PCF2119FU	bare die	168 bumps	PCF2119x
PCF2119IU	bare die	168 bumps	PCF2119x
PCF2119RU	bare die	168 bumps	PCF2119x
PCF2119SU	bare die	168 bumps	PCF2119x

### 4.1 Ordering options

Table 2. Ordering options

Product type number	IC revision	Sales item (12NC)	Delivery form
PCF2119AU/2DA/2	2	935273369033	chips in tray
PCF2119DU/2/2	2	935272743033	chips in tray
PCF2119FU/2/F2	2	935267829033	chips in tray
PCF2119IU/2DA/2	2	935294878033	chips in tray
PCF2119RU/2/F2	2	935263699033	chips in tray
PCF2119RU/2DB/2	2	935293133033	chips in tray
PCF2119SU/2/F2	2	935263700033	chips in tray

## 5. Marking

Table 3. Marking codes

Product type number	Marking code
PCF2119AU	PC2119-2
PCF2119DU	PC2119-2
PCF2119FU	PC2119-2
PCF2119IU	PC2119-2
PCF2119RU	PC2119-2
PCF2119SU	PC2119-2

6. Block diagram



Fig 1. Block diagram of PCF2119x

7. Pinning information

7.1 Pinning



## 7.2 Pin description

**Table 4. Pin description**

*Input or input/output pins must always be at a defined level ( $V_{SS}$  or  $V_{DD}$ ) unless otherwise specified.*

Symbol	Pin	Description
$V_{DD1}$	1 to 6	supply voltage 1 (logic)
$V_{DD2}$	7 to 14 <a href="#">[1]</a>	supply voltage 2 (for high voltage generator)
$V_{DD3}$	15 to 18 <a href="#">[1]</a>	supply voltage 3 (for high voltage generator)
E	19 <a href="#">[2]</a>	data bus clock input <ul style="list-style-type: none"> <li>• set HIGH to signal the start of a read or write operation</li> <li>• data is clocked in or out of the chip on the negative edge of the clock</li> </ul>
T1 and T2	20 and 21	test pins <ul style="list-style-type: none"> <li>• must be connected to <math>V_{SS1}</math></li> </ul>
$V_{SS1}$	22 to 29 <a href="#">[3]</a>	ground supply voltage 1 <ul style="list-style-type: none"> <li>• for all circuits, except of high voltage generator</li> </ul>
$V_{SS2}$	30 to 35 <a href="#">[3]</a>	ground supply voltage 2 <ul style="list-style-type: none"> <li>• for high voltage generator</li> </ul>
$V_{LCDSENSE}$	36	input for voltage multiplier regulation circuitry and for the bias level generation <ul style="list-style-type: none"> <li>• if <math>V_{LCD}</math> is generated internally then this pin must be connected to <math>V_{LCDOUT}</math> and <math>V_{LCDIN}</math></li> <li>• if <math>V_{LCD}</math> is generated externally then this pin must be connected to <math>V_{LCDIN}</math> only</li> </ul>
$V_{LCDOUT}$	37 to 43	$V_{LCD}$ output <ul style="list-style-type: none"> <li>• if <math>V_{LCD}</math> is generated internally then this pin must be connected to <math>V_{LCDIN}</math> and to <math>V_{LCDSENSE}</math></li> <li>• if <math>V_{LCD}</math> is generated externally then this pin must be left open-circuit</li> </ul>
$V_{LCDIN}$	44 to 49	input for LCD bias level generator <ul style="list-style-type: none"> <li>• if <math>V_{LCD}</math> is generated internally then this pin must be connected to <math>V_{LCDOUT}</math> and to <math>V_{LCDSENSE}</math></li> <li>• if <math>V_{LCD}</math> is generated externally then this pin must be connected to <math>V_{LCDSENSE}</math> and to the external <math>V_{LCD}</math> power supply</li> </ul>
dummy	50	-
R8 to R1, R17, R17DUP, R18, R9 to R16	51 to 58, 59, 100 141, 142 to 149	LCD row driver output <ul style="list-style-type: none"> <li>• R17 has two pins: R17 and R17DUP</li> <li>• R17 and R18 drive the icons</li> </ul>
C80 to C41, C40 to C1	60 to 99, 101 to 140	LCD column driver output
dummy	150	-
SCL	151 and 152 <a href="#">[4]</a>	I <sup>2</sup> C-bus serial clock input
T3	153	test pin <ul style="list-style-type: none"> <li>• open-circuit</li> <li>• not user accessible</li> </ul>

**Table 4. Pin description ...continued**

*Input or input/output pins must always be at a defined level ( $V_{SS}$  or  $V_{DD}$ ) unless otherwise specified.*

Symbol	Pin	Description
POR	154	external Power-On Reset (POR) input
PD	155	power-down mode select <ul style="list-style-type: none"> <li>for normal operation, pin PD must be LOW</li> </ul>
SDA	156 and 157 <a href="#">[4]</a>	I <sup>2</sup> C-bus serial data input/output
R/ $\overline{W}$	158	read/write input <ul style="list-style-type: none"> <li>pin R/<math>\overline{W}</math> = HIGH selects the read operation</li> <li>pin R/<math>\overline{W}</math> = LOW selects the write operation</li> <li>this pin has an internal pull-up resistor</li> </ul>
RS	159	register select pin <ul style="list-style-type: none"> <li>this pin has an internal pull-up resistor</li> </ul>
DB0 to DB2, DB3/SA0, DB4 to DB7	160 to 162, <a href="#">[5]</a> <a href="#">[6]</a> 163, 164 to 167	8 bit bidirectional data bus (bit 0 to bit 7) <ul style="list-style-type: none"> <li>the 8-bit bidirectional data bus (3-state) transfers data between the microcontroller and the PCF2119x</li> <li>pin DB7 may be used as the busy flag, signalling that internal operations are not yet completed</li> <li>4-bit operations the 4 higher order lines DB7 to DB4 are used, DB3 to DB0 must be left open-circuit</li> <li>data bus line DB3 has an alternative function (SA0) as the I<sup>2</sup>C-bus address pin</li> <li>each data line has its own internal pull-up resistor</li> </ul>
OSC	168	oscillator or external clock input <ul style="list-style-type: none"> <li>when the on-chip oscillator is used this pin must be connected to <math>V_{DD1}</math></li> </ul>

[1] Always put  $V_{DD2} = V_{DD3}$ .

[2] When the I<sup>2</sup>C-bus is used, the parallel interface pin E must be LOW.

[3] The substrate (rear side of the die) is wired to  $V_{SS}$  but should not be electrically connected.

[4] When the parallel bus is used, the pins SCL and SDA must be connected to  $V_{SS1}$  or  $V_{DD1}$ ; they must not be left open-circuit.

[5] In the I<sup>2</sup>C-bus read mode, ports DB7 to DB4 and DB2 to DB0 should be connected to  $V_{DD1}$  or left open-circuit.

[6] When the 4-bit interface is used without reading out from the PCF2119x (bit R/ $\overline{W}$  is set permanently to logic 0), the unused ports DB4 to DB0 can either be set to  $V_{SS1}$  or  $V_{DD1}$  instead of leaving them open-circuit.

## 8. Functional description

### 8.1 Oscillator and timing generator

The internal logic and the LCD drive signals of the PCF2119x are timed by the frequency  $f_{clk}$  which equals either the built in oscillator frequency  $f_{osc}$  or an external clock frequency  $f_{osc(ext)}$ .

#### 8.1.1 Timing generator

The timing generator produces the various signals required to drive the internal circuitry. Internal chip operation is not disturbed by operations on the data buses.

#### 8.1.2 Internal clock

To use the on-chip oscillator, pin OSC must be connected to  $V_{DD1}$ . The on-chip oscillator provides the clock signal for the display system. No external components are required.

#### 8.1.3 External clock

If an external clock will be used, the input is at pin OSC. The resulting display frame frequency is given by:

$$f_{fr} = \frac{f_{clk}}{3072} \quad (1)$$

**Remark:** Only in the power-down mode the clock is allowed to be stopped (pin OSC connected to  $V_{SS}$ ), otherwise the LCD is frozen in a DC state, which is not suitable for the liquid crystals.

### 8.2 Reset function and Power-On Reset (POR)

The PCF2119x must be reset externally when power is turned on. If no external reset is performed, the chip might start-up in an unwanted state.

For the external reset, pin POR has to be active HIGH. The reset has to be active for at least 3 oscillator periods in order for the reset to be executed. If the internal oscillator is used, the minimum reset activity time follows from the lowest possible oscillator frequency ( $f_{osc} = 140 \text{ kHz}$ ,  $t_{osc} \sim 7.1 \text{ } \mu\text{s}$ ,  $3 \times t_{osc} \sim 2.15 \text{ } \mu\text{s}$ ). The internal oscillator start-up time is  $200 \text{ } \mu\text{s}$  (typ) up to  $300 \text{ } \mu\text{s}$  (max) after power-on. In case that an external oscillator is used,  $t_{osc}$  is dependent from  $f_{osc(ext)}$ .

Afterwards the chip executes the Clear\_display instruction, which requires 165 oscillator cycles. After the reset the chip has the state shown in [Table 5](#) and is then ready for use.



Table 5. State after reset

Step	Function	Control bit and register state	Description	Reference
1	Clear_display	-	-	<a href="#">Table 17</a>
2	Entry_mode_set	bit I_D = 1	incremental cursor move direction	<a href="#">Table 19</a>
		bit S = 0	no display shift	
3	Display_ctl	bit D = 0	display off	<a href="#">Table 20</a>
		bit C = 0	cursor off	
		bit B = 0	cursor character blink off	
4	Function_set	bit DL = 1	8-bit interface	<a href="#">Table 13</a>
		bit M = 0	1-line display	
		bit SL = 0	1:18 multiplex drive mode	
		bit H = 0	normal instruction set	
5	default address pointer to DDRAM <sup>[1]</sup>	-	-	<a href="#">Table 23</a>
6	Icon_ctl	bit IM = 0	character mode, full display	<a href="#">Table 26</a>
		bit IB = 0	icon blink disabled	
7	Screen_conf	bit L = 0	default configuration	<a href="#">Table 24</a>
	Disp_conf	bit P = 0; bit Q = 0	default configurations	<a href="#">Table 25</a>
8	Temp_ctl	bit TC1 = 0; bit TC2 = 0	default temperature coefficient	<a href="#">Table 29</a>
9	VLCD_set	register V <sub>A</sub> = 0; register V <sub>B</sub> = 0	V <sub>LCD</sub> generator off	<a href="#">Table 33</a>
10	I <sup>2</sup> C-bus interface reset	-	-	-
11	HV_gen	bit S1 = 1; bit S0 = 0	V <sub>LCD</sub> generator set to 3 internal stages (4 voltage multipliers)	<a href="#">Table 31</a>

[1] The Busy Flag (BF) indicates the busy state (bit BF = 1) until initialization ends. The busy state lasts 2 ms. The chip may also be initialized by software (see [Table 45](#) and [Table 46](#)).

### 8.3 Power-down mode

The chip can be put into power-down mode by applying a HIGH-level to pin PD. In power-down mode all static currents are switched off (no internal oscillator, no bias level generation and all LCD outputs are internally connected to V<sub>SS</sub>).

During power-down, information in the RAM and the chip state are preserved. Instruction execution during power-down is possible when pin OSC is externally clocked.

### 8.4 LCD supply voltage generator

The LCD supply voltage may be generated on-chip. The V<sub>LCD</sub> generator is controlled by two internal 6-bit registers: V<sub>A</sub> and V<sub>B</sub>. Register V<sub>A</sub> is programmed with the voltage for character mode and register V<sub>B</sub> with the voltage for icon mode.

The nominal LCD operating voltage at room temperature is given by [Equation 2](#):

$$V_{LCD(nom)} = V_x \times 0.08 + 1.82 \quad (2)$$

Where V<sub>x</sub> is the integer value of the register V<sub>A</sub> or V<sub>B</sub>.

$V_{LCD}$  is sometimes referred as the LCD operating voltage ( $V_{oper}$ ).

### 8.4.1 Programming ranges

Possible values for  $V_A$  and  $V_B$  are between 0 to 63.

**Table 6. Values of  $V_A$  and  $V_B$  and the corresponding  $V_{LCD}$  values**

All values at  $T_{ref} = 27\text{ °C}$ ; allowed values are highlighted.

Integer values of $V_A$ and $V_B$	Corresponding value of $V_{LCD}$ in V	Integer values of $V_A$ and $V_B$	Corresponding value of $V_{LCD}$ in V	Integer values of $V_A$ and $V_B$	Corresponding value of $V_{LCD}$ in V
0	$V_{LCD}$ switched off	22	3.58	44	5.34
1	1.90	23	3.66	45	5.42
2	1.98	24	3.74	46	5.50
3	2.06	25	3.82	47	5.58
4	2.14	26	3.90	48	5.66
5	2.22	27	3.98	49	5.74
6	2.30	28	4.06	50	5.82
7	2.38	29	4.14	51	5.90
8	2.46	30	4.22	52	5.98
9	2.54	31	4.30	53	6.06
10	2.62	32	4.38	54	6.14
11	2.70	33	4.46	55	6.22
12	2.78	34	4.54	56	6.30
13	2.86	35	4.62	57	6.38
14	2.94	36	4.70	58	6.46
15	3.02	37	4.78	59	6.54
16	3.10	38	4.86	60	6.62
17	3.18	39	4.94	61	6.70
18	3.26	40	5.02	62	6.78
19	3.34	41	5.10	63	6.86
20	3.42	42	5.18		
21	3.50	43	5.26		

#### Remarks:

- Values producing more than 6.5 V at operating temperature are not allowed. Operation above this voltage may damage the device. When programming the operating voltage, the temperature coefficient of  $V_{LCDOUT}$  must be taken into account.
- Values below 2.2 V are below the specified operating range of the chip and are therefore not allowed.

When the LCD supply voltage is generated on-chip, the  $V_{LCD}$  pins should be decoupled to  $V_{SS}$  with a suitable capacitor. The generated  $V_{LCDOUT}$  is independent of  $V_{DD}$  and is temperature compensated.

In [Equation 2](#) the internal charge pump is not considered. However, if the supplied voltage to  $V_{DD2}$  and  $V_{DD3}$  is below the required  $V_{LCD}$ , it is necessary to use the internal charge pump. The multiplication factor indicates the number of stages used to increase the voltage. At multiplication factor 2 one, at multiplication factor 3 two and at multiplication

factor 4, three stages are used. A multiplication factor of for example, 4 does not mean that a voltage of  $4 \times V_{DD2,3}$  is generated in the internal high-voltage generator. The charge pump is part of a control loop. This means that the control loop aims to regulate  $V_{LCD}$  at the programmed value.

The ITO track resistance limit the speed by which the capacitors can be charged. The multiplication factor exceeds the required  $V_{LCD}$  under all circumstances (that is, at low temperatures and along with the temperature compensation, see [Section 10.2.2.4](#)). If still a higher multiplication factor is chosen,  $V_{LCD}$  will remain as set by [Equation 2](#) but the ripple will increase. The increase in ripple can be counteracted by increasing the external decoupling capacitor at  $V_{LCD}$ . A higher multiplication factor will also result in a higher current consumption (see [Section 16.6](#)). However the current that can be delivered will be higher, for example, for larger display area.

When the  $V_{LCD}$  generator and the direct mode are switched off, an external voltage may be supplied at connected pins  $V_{LCDIN}$  and  $V_{LCDOUT}$ .  $V_{LCDIN}$  and  $V_{LCDOUT}$  may be higher or lower than  $V_{DD2}$ .

In direct mode (see `Icon_ctl` instruction, [Section 10.2.3.3](#)) the internal  $V_{LCD}$  generator is turned off and the  $V_{LCDOUT}$  output voltage is directly connected to  $V_{DD2}$ . This reduces the current consumption depending on  $V_{DD2}$  value and LCD liquid properties.

The  $V_{LCD}$  generator ensures that, as long as  $V_{DD2}$  and  $V_{DD3}$  are in the valid range (2.2 V to 4 V), the required peak voltage  $V_{LCD} = 6.5$  V can be generated at any time.

### 8.5 LCD bias voltage generator

The intermediate bias voltages for the LCD display are also generated on-chip. This removes the need for an external resistive bias chain and significantly reduces the system current consumption. The optimum value of  $V_{LCD}$  depends on the multiplex rate, the LCD threshold voltage ( $V_{th}$ ) and the number of bias levels. Using a 5-level bias scheme for the 1:18 multiplex rate allows  $V_{LCD} < 5$  V for most LCD liquids.

The intermediate bias levels for the different multiplex rates are shown in [Table 7](#). These bias levels are automatically set to the given values when switching to the corresponding multiplex rate.

**Table 7. Bias levels as a function of multiplex rate**

Multiplex rate	Number of bias levels	Bias voltages					
		$V_1$	$V_2$	$V_3$	$V_4$	$V_5$	$V_6$
1:18	5	$V_{LCD}$	$\frac{3}{4}(V_{LCD} - V_{SS})$	$\frac{1}{2}(V_{LCD} - V_{SS})$	$\frac{1}{2}(V_{LCD} - V_{SS})$	$\frac{1}{4}(V_{LCD} - V_{SS})$	$V_{SS}$
1:9	5	$V_{LCD}$	$\frac{3}{4}(V_{LCD} - V_{SS})$	$\frac{1}{2}(V_{LCD} - V_{SS})$	$\frac{1}{2}(V_{LCD} - V_{SS})$	$\frac{1}{4}(V_{LCD} - V_{SS})$	$V_{SS}$
1:2	4	$V_{LCD}$	$\frac{2}{3}(V_{LCD} - V_{SS})$	$\frac{2}{3}(V_{LCD} - V_{SS})$	$\frac{1}{3}(V_{LCD} - V_{SS})$	$\frac{1}{3}(V_{LCD} - V_{SS})$	$V_{SS}$

The RMS on-state voltage ( $V_{on(RMS)}$ ) for the LCD is calculated with [Equation 3](#) and the RMS off-state voltage ( $V_{off(RMS)}$ ) with [Equation 4](#):

$$V_{on(RMS)} = V_{LCD} \sqrt{\frac{a^2 + 2a + n}{n \times (1 + a)^2}} \quad (3)$$

$$V_{off(RMS)} = V_{LCD} \sqrt{\frac{a^2 - 2a + n}{n \times (1 + a)^2}} \quad (4)$$

where the values of a are

a = 2 for 1/4 bias

a = 3 for 1/5 bias

and the values for n are

n = 2 for 1:2 multiplex rate

n = 9 for 1:9 multiplex rate

n = 18 for 1:18 multiplex rate.

Discrimination (D) is the ratio of  $V_{on(RMS)}$  to  $V_{off(RMS)}$  and is determined from [Equation 5](#).

Discrimination is a term which is defined as the ratio of the on and off RMS voltage across a segment. It can be thought of as a measurement of contrast.

$$D = \frac{V_{on(RMS)}}{V_{off(RMS)}} = \sqrt{\frac{(a + 1)^2 + (n - 1)}{(a - 1)^2 + (n - 1)}} \quad (5)$$

### 8.5.1 Electro-optical performance

Suitable values for  $V_{on(RMS)}$  and  $V_{off(RMS)}$  are dependant on the LCD liquid used. The RMS voltage, at which a pixel will be switched on or off, determine the transmissibility of the pixel.

For any given liquid, there are two threshold values defined. One point is at 10 % relative transmission (at  $V_{low}$ ) and the other at 90 % relative transmission (at  $V_{high}$ ), see [Figure 3](#). For a good contrast performance, the following rules should be followed:

$$V_{on(RMS)} \geq V_{high} \quad (6)$$

$$V_{off(RMS)} \leq V_{low} \quad (7)$$

$V_{on(RMS)}$  and  $V_{off(RMS)}$  are properties of the display driver and are affected by the selection of a, n (see [Equation 3](#) to [Equation 5](#)) and the  $V_{LCD}$  voltage.

$V_{low}$  and  $V_{high}$  are properties of the LCD liquid and can be provided by the module manufacturer.

It is important to match the module properties to those of the driver in order to achieve optimum performance.



Fig 3. Electro-optical characteristic: relative transmission curve of the liquid

### 8.6 LCD row and column drivers

The PCF2119x contains 18 row and 80 column drivers, which drive the appropriate LCD bias voltages in sequence to the display in accordance with the data to be displayed. R17 and R18 drive the icon rows. Unused outputs should be left open.

The bias voltages and the timing are selected automatically when the number of lines in the display is selected. [Figure 4](#) to [Figure 6](#) show typical waveforms.

The waveforms used to drive LC displays inherently produce a DC voltage across the display cell. The PCF2119x compensates for the DC voltage by inverting the waveforms on alternate frames (called frame inversion mode or driving scheme A).

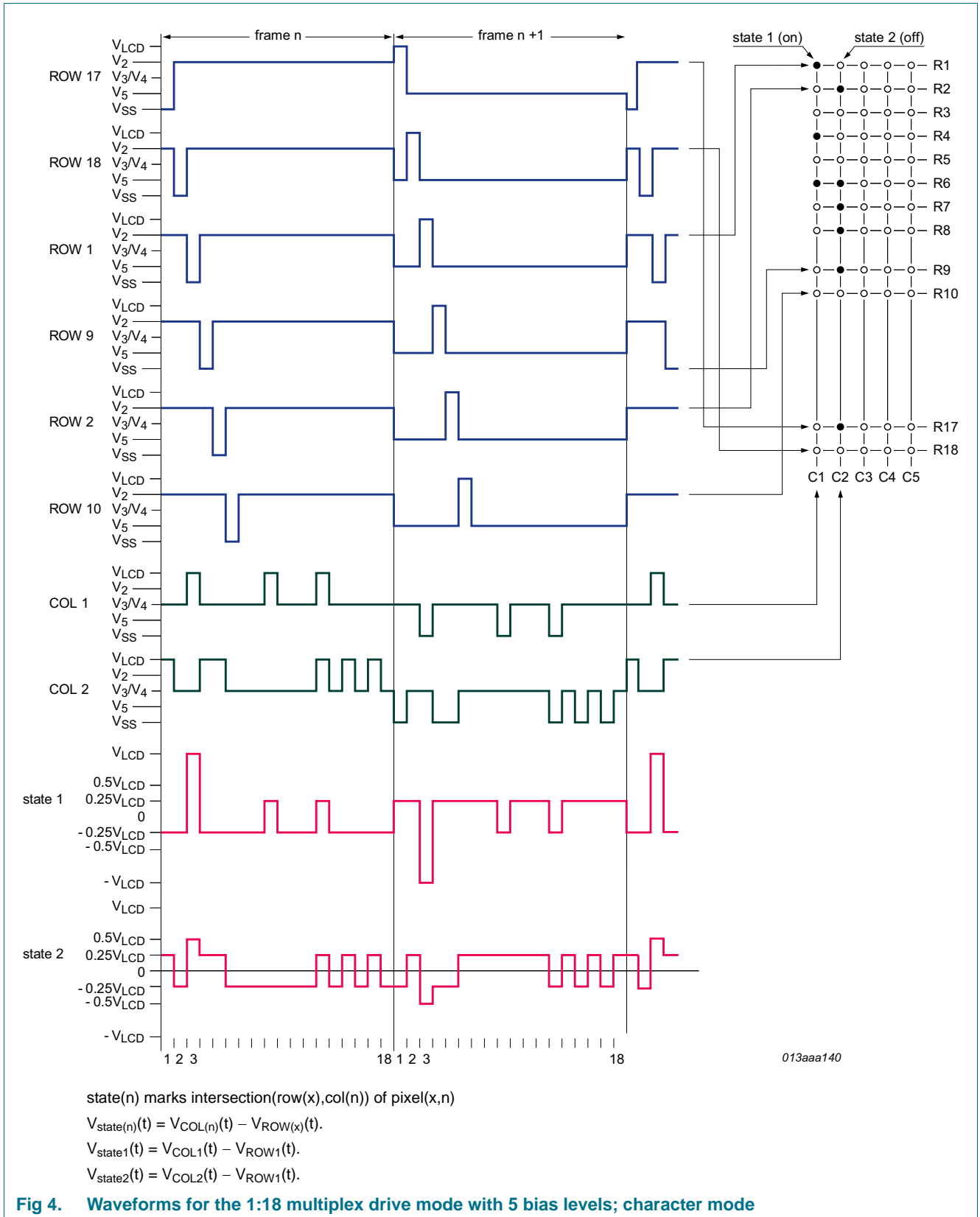

**Fig 4. Waveforms for the 1:18 multiplex drive mode with 5 bias levels; character mode**



**Fig 5. Waveforms for the 1:9 multiplex drive mode with 5 bias levels; character mode, R9 to R16 and R18 open**



state(n) marks intersection(row(x),col(n)) of pixel(x,n)

$$V_{state(n)}(t) = V_{COL(n)}(t) - V_{ROW(x)}(t).$$

$$V_{state1}(t) = V_{COL1}(t) - V_{ROW17}(t).$$

$$V_{state2}(t) = V_{COL2}(t) - V_{ROW17}(t).$$

$$V_{state3}(t) = V_{COL3}(t) - V_{ROW1\ to\ 16}(t).$$

Fig 6. Waveforms for the 1:2 multiplex drive mode with 4 bias levels; icon mode



## 9. Display data RAM and ROM

### 9.1 DDRAM

The Display Data RAM (DDRAM) stores up to 80 characters of display data represented by 8-bit character codes. RAM locations which are not used for storing display data can be used as general purpose RAM.

The basic RAM to display addressing scheme is shown in [Figure 7](#), [Figure 8](#) and [Figure 9](#). With no display shift the characters represented by the codes in the first 32 RAM locations starting at address 00h are displayed in line 1.

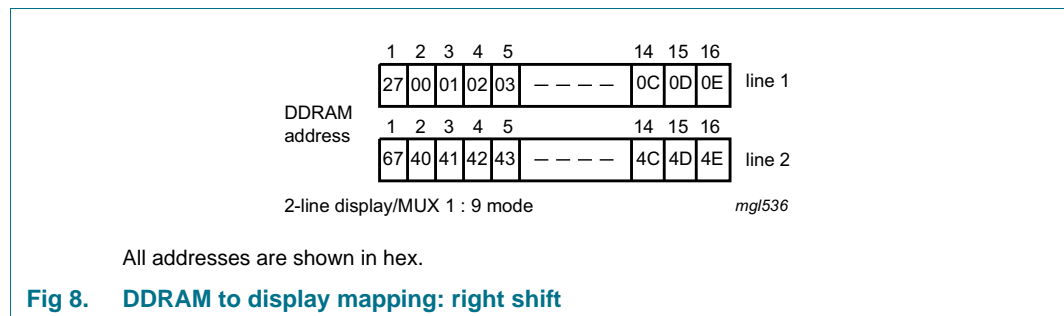
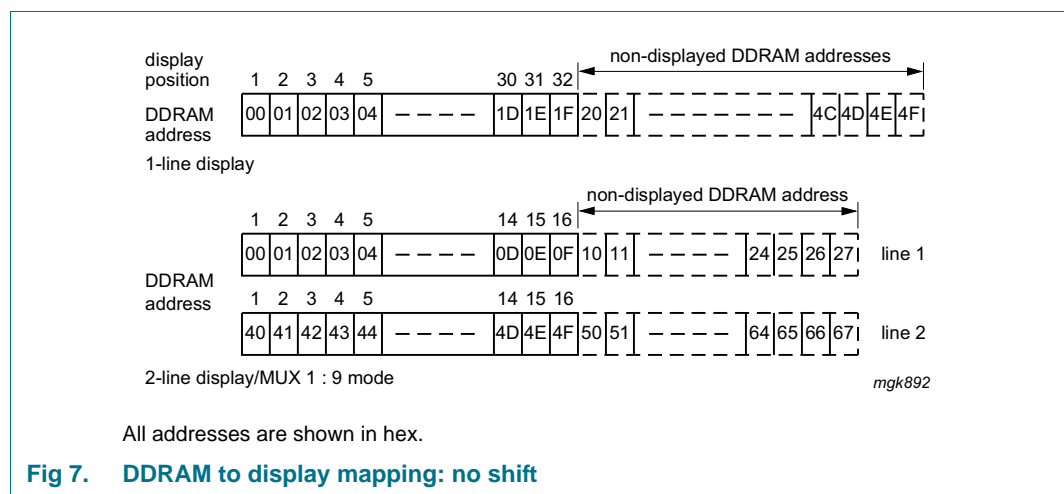



When data is written to or read from the DDRAM, wrap-around occurs from the end of one line to the start of the next line. When the display is shifted each line wraps around within itself, independently of the others. Thus all lines are shifted and wrapped around together. The address ranges and wrap-around operations for the various modes are shown in [Table 8](#).

**Table 8. Address space and wrap-around operation**

Mode	1 × 32	2 × 16	1 × 16
Address space	00h to 4Fh	00h to 27h; 40h to 67h	00h to 27h
Read/write wrap-around (moves to next line)	4Fh to 00h	27h to 40h; 67h to 00h	27h to 00h
Display shift wrap-around (stays within line)	4Fh to 00h	27h to 00h; 67h to 40h	27h to 00h

## 9.2 CGROM

The Character Generator ROM (CGROM) contains 240 character patterns in a 5 × 8 dot format from 8-bit character codes. [Figure 10](#) to [Figure 15](#) show the character sets that are currently implemented.

upper 4 bits lower 4 bits	0000	0001	0010	0011	0100	0101	0110	0111	1000	1001	1010	1011	1100	1101	1110	1111
xxxx 0000	1	0	1	2	3	4	5	6	7	8	9	:	;	<	=	>
xxxx 0001	2	!	"	#	\$	%	&	'	(	)	*	+	,	-	.	/
xxxx 0010	3	:	;	<	=	>	?	@	A	B	C	D	E	F	G	H
xxxx 0011	4	I	J	K	L	M	N	O	P	Q	R	S	T	U	V	W
xxxx 0100	5	X	Y	Z	[	\	]	^	_	`	{		}	~		
xxxx 0101	6															
xxxx 0110	7															
xxxx 0111	8															
xxxx 1000	9															
xxxx 1001	10															
xxxx 1010	11															
xxxx 1011	12															
xxxx 1100	13															
xxxx 1101	14															
xxxx 1110	15															
xxxx 1111	16															

mce190

The first column (0000) is the CGRAM, the other 15 columns (0001 to 1111) are the CGROM.

Fig 10. Character set 'A' in CGROM

upper 4 bits lower 4 bits	0000	0001	0010	0011	0100	0101	0110	0111	1000	1001	1010	1011	1100	1101	1110	1111	
xxxx 0000	1	.		O	P	Q	R	S	T	U	V	W	X	Y	Z		
xxxx 0001	2	[arrow]	!	1	2	3	4	5	6	7	8	9	:	;	<	>	
xxxx 0010	3	[arrow]	"	z	0	1	2	3	4	5	6	7	8	9	:	<	>
xxxx 0011	4	[arrow]	*	3	4	5	6	7	8	9	:	<	>	0	1	2	
xxxx 0100	5	[arrow]	x	4	5	6	7	8	9	:	<	>	y	z			
xxxx 0101	6	[arrow]	1	2	3	4	5	6	7	8	9	:	<	>	y	z	
xxxx 0110	7	[arrow]	2	3	4	5	6	7	8	9	:	<	>	0	1	2	
xxxx 0111	8	[arrow]	3	4	5	6	7	8	9	:	<	>	0	1	2	3	
xxxx 1000	9	[arrow]	4	5	6	7	8	9	:	<	>	0	1	2	3	4	
xxxx 1001	10	[arrow]	5	6	7	8	9	:	<	>	0	1	2	3	4	5	
xxxx 1010	11	[arrow]	6	7	8	9	:	<	>	0	1	2	3	4	5	6	
xxxx 1011	12	[arrow]	7	8	9	:	<	>	0	1	2	3	4	5	6	7	
xxxx 1100	13	[arrow]	8	9	:	<	>	0	1	2	3	4	5	6	7	8	
xxxx 1101	14	[arrow]	9	:	<	>	0	1	2	3	4	5	6	7	8	9	
xxxx 1110	15	[arrow]	:	<	>	0	1	2	3	4	5	6	7	8	9	:	
xxxx 1111	16	[arrow]	<	>	0	1	2	3	4	5	6	7	8	9	:	<	

mce173

The first column (0000) is the CGRAM, the other 15 columns (0001 to 1111) are the CGROM.

Fig 11. Character set 'D' in CGROM

upper lower 4 bits 4 bits	0000	0001	0010	0011	0100	0101	0110	0111	1000	1001	1010	1011	1100	1101	1110	1111
xxxx 0000	1	•		•	•	•	•	•	•	•	•	•	•	•	•	•
xxxx 0001	2	•	•	•	•	•	•	•	•	•	•	•	•	•	•	•
xxxx 0010	3	•	•	•	•	•	•	•	•	•	•	•	•	•	•	•
xxxx 0011	4	•	•	•	•	•	•	•	•	•	•	•	•	•	•	•
xxxx 0100	5	•	•	•	•	•	•	•	•	•	•	•	•	•	•	•
xxxx 0101	6	•	•	•	•	•	•	•	•	•	•	•	•	•	•	•
xxxx 0110	7	•	•	•	•	•	•	•	•	•	•	•	•	•	•	•
xxxx 0111	8	•	•	•	•	•	•	•	•	•	•	•	•	•	•	•
xxxx 1000	9	•	•	•	•	•	•	•	•	•	•	•	•	•	•	•
xxxx 1001	10	•	•	•	•	•	•	•	•	•	•	•	•	•	•	•
xxxx 1010	11	•	•	•	•	•	•	•	•	•	•	•	•	•	•	•
xxxx 1011	12	•	•	•	•	•	•	•	•	•	•	•	•	•	•	•
xxxx 1100	13	•	•	•	•	•	•	•	•	•	•	•	•	•	•	•
xxxx 1101	14	•	•	•	•	•	•	•	•	•	•	•	•	•	•	•
xxxx 1110	15	•	•	•	•	•	•	•	•	•	•	•	•	•	•	•
xxxx 1111	16	•	•	•	•	•	•	•	•	•	•	•	•	•	•	•

mgu552

The first column (0000) is the CGRAM, the other 15 columns (0001 to 1111) are the CGROM.

Fig 12. Character set 'F' in CGROM

upper lower 4 bits 4 bits	0000	0001	0010	0011	0100	0101	0110	0111	1000	1001	1010	1011	1100	1101	1110	1111
xxxx 0000	1	!	@	A	B	C	D	E	F	G	H	I	J	K	L	M
xxxx 0001	2	N	O	P	Q	R	S	T	U	V	W	X	Y	Z	[	]
xxxx 0010	3	^	_	`	a	b	c	d	e	f	g	h	i	j	k	l
xxxx 0011	4	m	n	o	p	q	r	s	t	u	v	w	x	y	z	{
xxxx 0100	5		~													
xxxx 0101	6															
xxxx 0110	7															
xxxx 0111	8															
xxxx 1000	9															
xxxx 1001	10															
xxxx 1010	11															
xxxx 1011	12															
xxxx 1100	13															
xxxx 1101	14															
xxxx 1110	15															
xxxx 1111	16															

001aan760

The first column (0000) is the CGRAM, the other 15 columns (0001 to 1111) are the CGROM.

Fig 13. Character set 'I' in CGROM

lower 4 bits \ upper 4 bits	0000	0001	0010	0011	0100	0101	0110	0111	1000	1001	1010	1011	1100	1101	1110	1111
xxxx 0000	1	•	•	•	•	P	Q	R	S	T	U	V	W	X	Y	Z
xxxx 0001	2	0	1	2	3	4	5	6	7	8	9	:	;	<	=	>
xxxx 0010	3	;	;	;	;	;	;	;	;	;	;	;	;	;	;	;
xxxx 0011	4	;	;	;	;	;	;	;	;	;	;	;	;	;	;	;
xxxx 0100	5	;	;	;	;	;	;	;	;	;	;	;	;	;	;	;
xxxx 0101	6	;	;	;	;	;	;	;	;	;	;	;	;	;	;	;
xxxx 0110	7	;	;	;	;	;	;	;	;	;	;	;	;	;	;	;
xxxx 0111	8	;	;	;	;	;	;	;	;	;	;	;	;	;	;	;
xxxx 1000	9	;	;	;	;	;	;	;	;	;	;	;	;	;	;	;
xxxx 1001	10	;	;	;	;	;	;	;	;	;	;	;	;	;	;	;
xxxx 1010	11	;	;	;	;	;	;	;	;	;	;	;	;	;	;	;
xxxx 1011	12	;	;	;	;	;	;	;	;	;	;	;	;	;	;	;
xxxx 1100	13	;	;	;	;	;	;	;	;	;	;	;	;	;	;	;
xxxx 1101	14	;	;	;	;	;	;	;	;	;	;	;	;	;	;	;
xxxx 1110	15	;	;	;	;	;	;	;	;	;	;	;	;	;	;	;
xxxx 1111	16	;	;	;	;	;	;	;	;	;	;	;	;	;	;	;

mgf535

The first column (0000) is the CGRAM, the other 15 columns (0001 to 1111) are the CGROM.

Fig 14. Character set 'R' in CGROM

upper 4 bits lower 4 bits	0000	0001	0010	0011	0100	0101	0110	0111	1000	1001	1010	1011	1100	1101	1110	1111
xxxx 0000	1	▀		□	▣	▤	▥	▦	▧	▨	▩	▪	▫	▬	▭	▮
xxxx 0001	2	⊕	⊖	⊗	⊘	⊙	⊚	⊛	⊜	⊝	⊞	⊟	⊠	⊡	⊢	⊣
xxxx 0010	3	⊤	⊥	⊦	⊧	⊨	⊩	⊪	⊫	⊬	⊭	⊮	⊯	⊰	⊱	⊲
xxxx 0011	4	⊳	⊴	⊵	⊶	⊷	⊸	⊹	⊺	⊻	⊼	⊽	⊾	⊿	Ⓚ	Ⓛ
xxxx 0100	5	Ⓜ	Ⓨ	Ⓩ	ⓐ	ⓑ	ⓓ	ⓔ	ⓖ	ⓗ	ⓘ	ⓙ	ⓚ	ⓛ	ⓜ	ⓞ
xxxx 0101	6	ⓟ	ⓠ	ⓡ	ⓢ	ⓣ	ⓤ	ⓥ	ⓦ	ⓧ	ⓨ	ⓩ	⓪	⓫	⓬	⓭
xxxx 0110	7	⓮	⓯	⓰	⓱	⓲	⓳	⓴	⓵	⓶	⓷	⓸	⓹	⓺	⓻	⓼
xxxx 0111	8	⓽	⓿	Ⓚ	Ⓛ	Ⓜ	Ⓨ	Ⓩ	ⓐ	ⓑ	ⓓ	ⓔ	ⓖ	ⓗ	ⓘ	ⓙ
xxxx 1000	9	ⓛ	ⓞ	ⓟ	ⓠ	ⓡ	ⓢ	ⓣ	ⓤ	ⓥ	ⓦ	ⓧ	ⓨ	ⓩ	⓪	⓫
xxxx 1001	10	⓬	⓭	⓮	⓯	⓰	⓱	⓲	⓳	⓴	⓵	⓶	⓷	⓸	⓹	⓺
xxxx 1010	11	⓻	⓼	⓽	⓿	Ⓚ	Ⓛ	Ⓜ	Ⓨ	Ⓩ	ⓐ	ⓑ	ⓓ	ⓔ	ⓖ	ⓗ
xxxx 1011	12	ⓟ	ⓠ	ⓡ	ⓢ	ⓣ	ⓤ	ⓥ	ⓦ	ⓧ	ⓨ	ⓩ	⓪	⓫	⓬	⓭
xxxx 1100	13	⓮	⓯	⓰	⓱	⓲	⓳	⓴	⓵	⓶	⓷	⓸	⓹	⓺	⓻	⓼
xxxx 1101	14	⓽	⓿	Ⓚ	Ⓛ	Ⓜ	Ⓨ	Ⓩ	ⓐ	ⓑ	ⓓ	ⓔ	ⓖ	ⓗ	ⓘ	ⓙ
xxxx 1110	15	ⓟ	ⓠ	ⓡ	ⓢ	ⓣ	ⓤ	ⓥ	ⓦ	ⓧ	ⓨ	ⓩ	⓪	⓫	⓬	⓭
xxxx 1111	16	⓮	⓯	⓰	⓱	⓲	⓳	⓴	⓵	⓶	⓷	⓸	⓹	⓺	⓻	⓼

mg1534

The first column (0000) is the CGRAM, the other 15 columns (0001 to 1111) are the CGROM.

Fig 15. Character set 'S' in CGROM



### 9.3 CGRAM

Up to 16 user defined characters may be stored in the Character Generator RAM (CGRAM). Some CGRAM characters (see [Figure 22](#)) are also used to drive icons:

- 8 CGRAM characters if icons blink and both icon rows are used in the application
- 4 CGRAM characters if no icons blink but both icon rows are used in the application
- 0 CGRAM characters if no icons are driven by the icon rows

When the icons blink option is enabled, double the number of CGRAM characters are used since both the on and off state of an icon is defined.

The CGROM and CGRAM use a common address space, of which the first column is reserved for the CGRAM (see [Figure 10](#) to [Figure 15](#)). An example of a user defined character is given in [Section 16.14 on page 67](#).

[Figure 16](#) shows the addressing principle for the CGRAM.

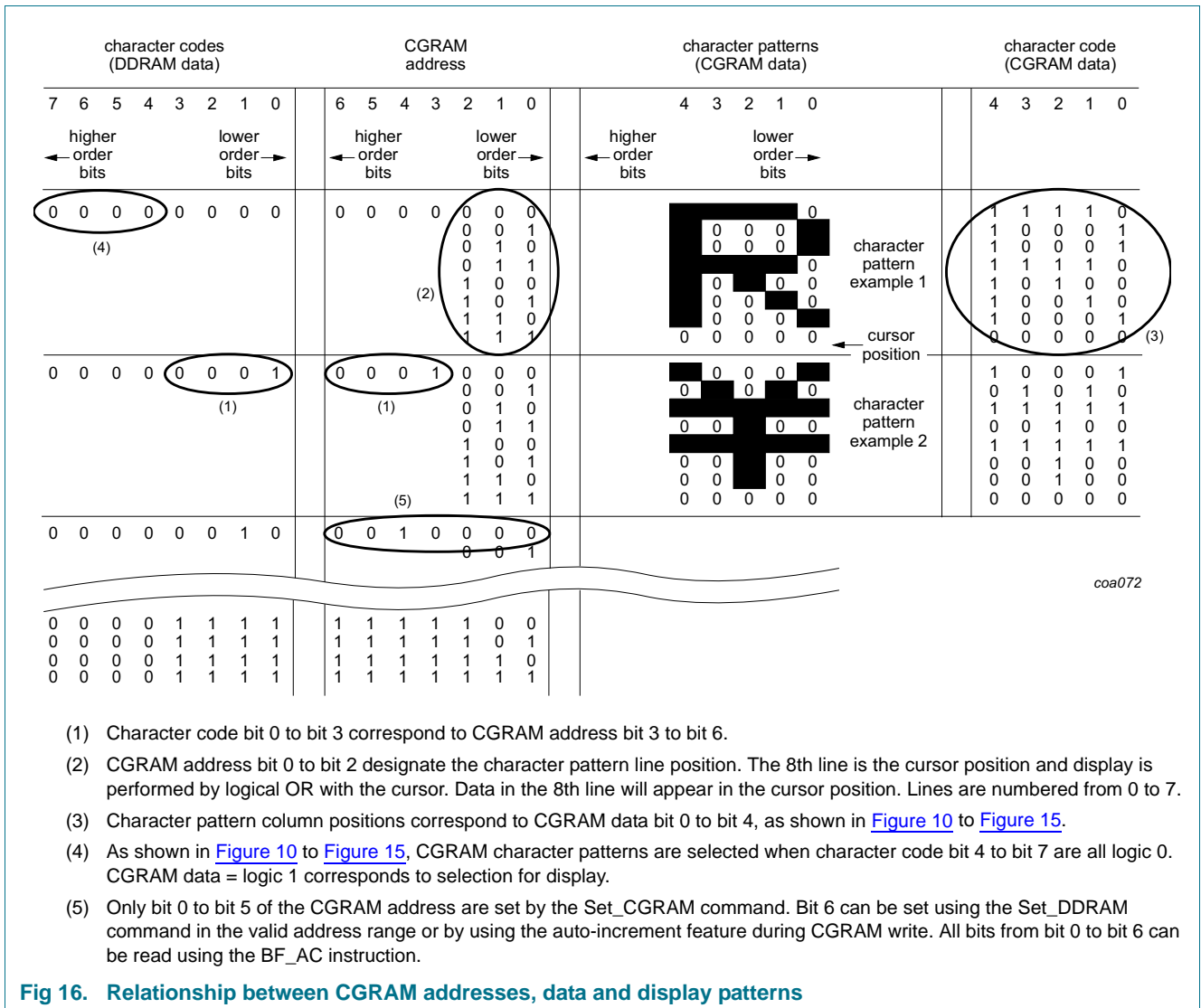

### 9.4 Cursor control circuit

The cursor control circuit generates the cursor underline and/or cursor blink as shown in [Figure 17](#) at the DDRAM address contained in the address counter.

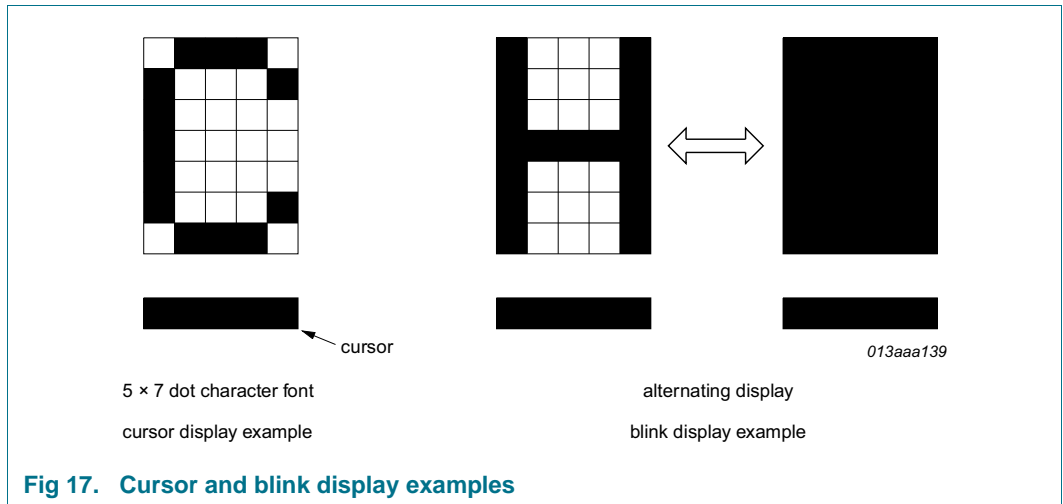

Fig 17. Cursor and blink display examples

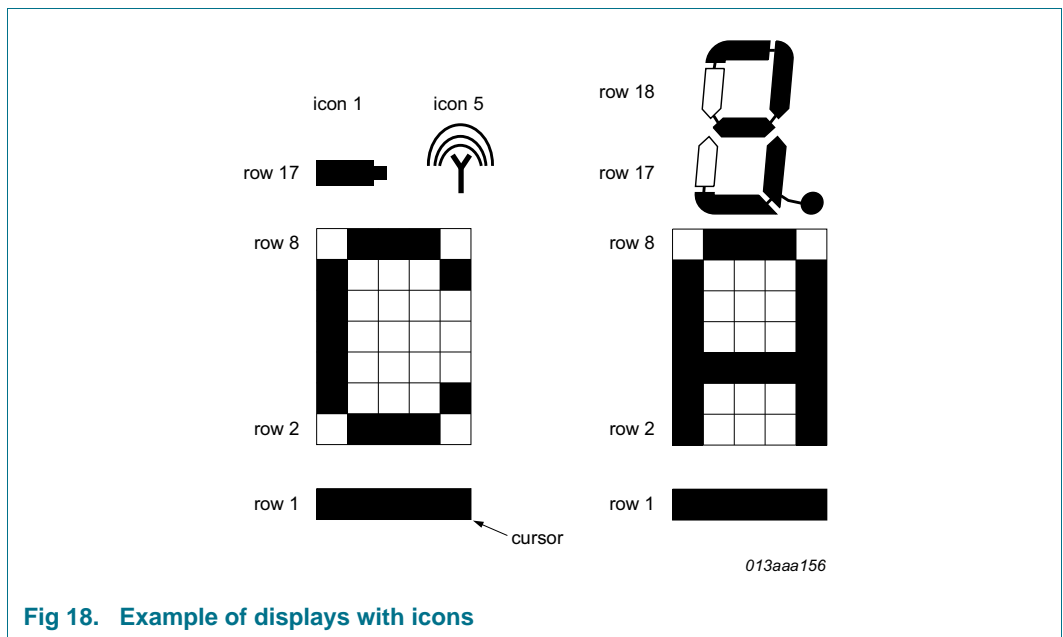

Fig 18. Example of displays with icons

## 10. Registers

The PCF2119x has two 8-bit registers, an instruction register and a data register. Only these two registers can be directly controlled by the microcontroller. Before an internal operation, the control information is stored temporarily in these registers, to allow interfacing to various types of microcontrollers which operate at different speeds or to allow interface to peripheral control ICs.

The instruction set for the parallel interface is shown in [Table 12](#) together with their execution time. Details about the parallel interface can be found in [Section 11.1](#). Examples of operations on a 4-bit bus are given in [Table 40](#), on a 8-bit bus in [Table 41](#), [Table 42](#) and [Table 43](#).

When using the I<sup>2</sup>C-bus, the instruction has to be commenced with a control byte as shown in [Table 9](#). Details about the I<sup>2</sup>C-bus interface can be found in [Section 11.2](#). An example of operations on the I<sup>2</sup>C-bus is given in [Table 44](#).

**Table 9. Instruction set for I<sup>2</sup>C-bus commands**

Control byte								Command byte								I <sup>2</sup> C-bus command
CO	RS	0	0	0	0	0	0	DB7	DB6	DB5	DB4	DB3	DB2	DB1	DB0	<a href="#">[1]</a>

[1]  $\overline{R/W}$  is set together with the slave address (see [Table 34](#)).

**Table 10. Control byte bit description**

Bit	Symbol	Value	Description
7	CO	0	last control byte
		1	another control byte follows after data/command
6	RS	0	instruction register selected
		1	data register selected
5 to 0	-	0	default logic 0

Instructions are of 4 types, those that:

1. Designate PCF2119x functions like display format, data length, etc.
2. Set internal RAM addresses
3. Perform data transfer with internal RAM
4. Others, like read 'busy flag' and read 'address counter'

In normal use, type 3 instructions are used most frequently. However, automatic incrementing by 1 (or decrementing by 1) of internal RAM addresses after each data write lessens the microcontroller program load. The display shift in particular can be performed concurrently with display data write, enabling the designer to develop systems in minimum time with maximum programming efficiency.

During internal operation, no instructions other than the BF\_AC instruction will be executed. Because the busy flag is set to logic 1 while an instruction is being executed, check to ensure it is logic 0 before sending the next instruction or wait for the maximum instruction execution time, as given in [Table 12](#). An instruction sent while the busy flag is logic 1 will not be executed.

The RS bit determines which register will be accessed and the  $\overline{R/W}$  bit indicates if it is a read or a write operation (see [Table 11](#)).

**Table 11. Register access selection**

Symbol	Value	Description
RS		<b>register select</b>
	0	instruction register <sup>[1]</sup>
	1	data register <sup>[2]</sup>
$\overline{R/W}$		<b>read/write</b>
	0	write operation
	1	read operation

[1] There is only write access to the instruction register, but read access to the busy flag (BF) and the address counter (AC) of the BF\_AC instruction (see [Section 10.2.1.2](#)).

[2] Write and read access.

Details of the instructions are explained in subsequent sections.

## 10.1 Data register

The data register temporarily stores data to be read from the DDRAM and CGRAM. Prior to being read by the Read\_data instruction, data from the DDRAM or CGRAM, corresponding to the address in the instruction register, is written to the data register.

## 10.2 Instruction register

The instruction register stores instruction codes such as Clear\_display, Curs\_disp\_shift, and address information for the Display Data RAM (DDRAM) and Character Generator RAM (CGRAM). The instruction register can be written to but not read from by the system controller.

The instruction register is sectioned into basic, standard and extended instructions. Bit H = 1 of the Function\_set instruction (see [Section 10.2.1.1](#)) sets the chip into extended instruction set mode.

Table 12. Instruction register overview

Instruction	Bits <sup>[1]</sup>											Required clock cycles <sup>[2]</sup>	Reference
	RS	R/W	7	6	5	4	3	2	1	0			
<b>Basic instructions (bit H = 0 or 1)</b>													
NOP <sup>[3]</sup>	0	0	0	0	0	0	0	0	0	0	0	3	-
Function_set	0	0	0	0	1	DL	0	M	SL	H	3	<a href="#">Section 10.2.1.1</a>	
BF_AC	0	1	BF	AC								0	<a href="#">Section 10.2.1.2</a>
Read_data	1	1	READ_DATA									3	<a href="#">Section 10.2.1.3</a>
Write_data	1	0	WRITE_DATA									3	<a href="#">Section 10.2.1.4</a>
<b>Standard instructions (bit H = 0)</b>													
Clear_display	0	0	0	0	0	0	0	0	0	0	1	165	<a href="#">Section 10.2.2.1</a>
Return_home	0	0	0	0	0	0	0	0	0	1	0	3	<a href="#">Section 10.2.2.2</a>
Entry_mode_set	0	0	0	0	0	0	0	1	I_D	S	3	<a href="#">Section 10.2.2.3</a>	
Display_ctl	0	0	0	0	0	0	1	D	C	B	3	<a href="#">Section 10.2.2.4</a>	
Curs_disp_shift	0	0	0	0	0	1	SC	RL	0	0	3	<a href="#">Section 10.2.2.5</a>	
Set_CGRAM	0	0	0	1	ACG							3	<a href="#">Section 10.2.2.6</a>
Set_DDRAM	0	0	1	ADD							3	<a href="#">Section 10.2.2.7</a>	
<b>Extended instructions (bit H = 1)</b>													
Reserved <sup>[4]</sup>	0	0	0	0	0	0	0	0	0	0	1	-	-
Screen_conf	0	0	0	0	0	0	0	0	0	1	L	3	<a href="#">Section 10.2.3.1</a>
Disp_conf	0	0	0	0	0	0	0	1	P	Q	3	<a href="#">Section 10.2.3.2</a>	
Icon_ctl	0	0	0	0	0	0	1	IM	IB	DM	3	<a href="#">Section 10.2.3.3</a>	
Temp_ctl	0	0	0	0	0	1	0	0	TC1	TC2	3	<a href="#">Section 10.2.3.4</a>	
HV_gen	0	0	0	1	0	0	0	0	S1	S0	3	<a href="#">Section 10.2.3.5</a>	
VLCD_set	0	0	1	V	VA or VB							3	<a href="#">Section 10.2.3.6</a>

[1] The bits 0 to 7 correspond with the data bus lines DB0 to DB7.

[2] f<sub>osc</sub> cycles.

[3] No operation.

[4] Do not use.

## 10.2.1 Basic instructions (bit H = 0 or 1)

### 10.2.1.1 Function\_set

Table 13. Function\_set bit description

Bit	Symbol	Value	Description
RS	-	0	see <a href="#">Table 11</a>
R/W	-	0	
7 to 5	-	001	fixed value
4	DL		<b>interface data length (for parallel mode only)</b>
		0 <sup>[1]</sup>	2 × 4 bits (DB7 to DB4)
		1 <sup>[2]</sup>	8 bits (DB7 to DB0)
3	-	0	unused

Table 13. Function\_set bit description ...continued

Bit	Symbol	Value	Description
2	M	[3]	<b>number of display lines</b>
		0	1 line × 32 characters
		1 [4]	2 line × 16 characters
1	SL		<b>multiplex mode</b>
		0	1:18 multiplex drive mode, 1 × 32 or 2 × 16 character display
		1 [4][5]	1:9 multiplex drive mode, 1 × 16 character display
0	H		<b>instruction set control</b>
		0	basic instruction set plus standard instruction set
		1 [4]	basic instruction set plus extended instruction set

- [1] When 4-bit width is selected, data is transmitted in two cycles using the parallel-bus. In a 4-bit application ports DB3 to DB0 should be left open-circuit (internal pull-ups).
- [2] Default value after power-on in I<sup>2</sup>C-bus mode.
- [3] No impact if SL = 1.
- [4] Due to the internal pull-ups on DB3 to DB0 in a 4-bit application, the first Function\_set after power-on sets bits M, SL and H to logic 1. A second Function\_set must be sent to set bits M, SL and H to the required values.
- [5] Independent of bit M and bit L of the Screen\_conf instruction (see Section 10.2.3.1). Only row 1 to row 8 and row 17 are used. All other rows must be left open-circuit. The DDRAM map is the same as in the 2 × 16 character display mode, however, the second line cannot be displayed.

### 10.2.1.2 BF\_AC instructions

Table 14. BF\_AC bit

Bit	Symbol	Value	Description
RS	-	0	see Table 11
R/W	-	1	
7	BF	[1]	<b>read busy flag</b>
		0	next instruction will be executed
		1	internal operation is in progress; next instruction will not be executed until BF = 0
6 to 0	AC	0000000 to 1111111	<b>read address counter</b>

- [1] It is recommended that the BF status is checked before the next write operation is started.

**Busy flag:** The busy flag indicates the internal status of the PCF2119x. A logic 1 indicates that the chip is busy and further instructions will not be accepted. The busy flag is output to pin DB7 when bit RS = 0 and bit R/W = 1. Instructions should only be started after checking that the busy flag is at logic 0 or after waiting for the required number of cycles.

**Address counter:** The address counter is used by both CGRAM and DDRAM, and its value is determined by the previous Set\_CGRAM and Set\_DDRAM instruction. After a read/write operation the address counter is automatically incremented or decremented by 1. The address counter value is output to the bus (DB6 to DB0) when bit RS = 0 and bit R/W = 1.

### 10.2.1.3 Read\_data

Table 15. Read\_data bit description

Bit	Symbol	Value	Description
RS	-	1	see <a href="#">Table 11</a>
R/W	-	1	
7 to 0	READ_DATA	00000000 to 11111111	<b>read data from CGRAM or DDRAM</b>

**Read\_data from CGRAM or DDRAM:** Read\_data reads binary 8-bit data from the CGRAM or DDRAM. The most recent 'set address' command (Set\_CGRAM or Set\_DDRAM) determines whether the CGRAM or DDRAM is to be read.

The Read\_data instruction gates the content of the data register to the bus while pin E is HIGH. After pin E goes LOW again, internal operation increments (or decrements) the address counter and stores RAM data corresponding to the new address counter into the data register.

There are only three instructions that update the data register:

- Set\_CGRAM
- Set\_DDRAM
- Read\_data from CGRAM or DDRAM

Other instructions (e.g. Write\_data, Curs\_disp\_shift, Clear\_display and Return\_home) do not modify the value of the data register.

### 10.2.1.4 Write\_data

Table 16. Write\_data bit description

Bit	Symbol	Value	Description
RS	-	1	see <a href="#">Table 11</a>
R/W	-	0	
7 to 0	WRITE_DATA	00000000 to 11111111	<b>write data to CGRAM or DDRAM</b>

**Write\_data to CGRAM or DDRAM:** Write\_data writes binary 8-bit data to the CGRAM or the DDRAM.

The previous Set\_CGRAM or Set\_DDRAM command determines if data is written into CGRAM or DDRAM. After writing, the address counter automatically increments or decrements by 1, in accordance with the Entry\_mode\_set (see [Section 10.2.2.3](#)). Only bit 4 to bit 0 of CGRAM data are valid, bit 7 to bit 5 are 'don't care'.

## 10.2.2 Standard instructions (bit H = 0)

### 10.2.2.1 Clear\_display

Table 17. Clear\_display bit description

Bit	Symbol	Value	Description
RS	-	0	see <a href="#">Table 11</a>
R/W	-	0	
7 to 0	-	00000001	fixed value

**Clear\_display:** writes usually the character code 20h (blank pattern) into all DDRAM addresses except for the character set 'R' where the character code 20h is not a blank pattern.

When using character set 'R', the following alternative instruction set has to be used:

1. Switch display off (Display\_ctl, bit D = 0).
2. Write a blank pattern into all DDRAM addresses (Write\_data).
3. Switch display on (Display\_ctl, bit D = 1).

In addition Clear\_display

- sets the DDRAM address counter to logic 0
- returns the display to its original position, if it was shifted. Thus, the display disappears and the cursor or blink position goes to the left edge of the display
- sets entry mode bit I\_D = 1 (increment mode); bit S of entry mode does not change

The instruction Clear\_display requires extra execution time. This may be allowed by checking the busy flag bit BF or by waiting until the 165 clock cycles have elapsed. The latter must be applied where no read-back options are foreseen, as in some Chip-On-Glass (COG) applications.

### 10.2.2.2 Return\_home

Table 18. Return\_home bit description

Bit	Symbol	Value	Description
RS	-	0	see <a href="#">Table 11</a>
R/W	-	0	
7 to 0	-	00000010	fixed value

**Return\_home:** Sets the DDRAM address counter to logic 0 and switches a shifted display back to an unshifted state. The DDRAM content remain unchanged. The cursor or blink position goes to the left of the first display line. Bit I\_D and bit S of the Entry\_mode\_set instruction remain unchanged.



### 10.2.2.3 Entry\_mode\_set

Table 19. Entry\_mode\_set bit description

Bit	Symbol	Value	Description
RS	-	0	see <a href="#">Table 11</a>
R/W	-	0	
7 to 2	-	000001	fixed value
1	I_D		<b>address increment or decrement</b>
		0	DDRAM or CGRAM address decrements by 1, cursor moves to the left
		1	DDRAM or CGRAM address increments by 1, cursor moves to the right
0	S		<b>shift display to the left or right</b>
		0	display does not shift
		1	display shifts

**Bit I\_D:** When bit I\_D = 1 the DDRAM or CGRAM address increments by 1 when data is written into or read from the DDRAM or CGRAM. The cursor or blink position moves to the right.

When bit I\_D = 0 the DDRAM or CGRAM address decrements by 1 when data is written into or read from the DDRAM or CGRAM. The cursor or blink position moves to the left.

The cursor underline and cursor character blink are inhibited when the CGRAM is accessed.

**Bit S:** When bit S = 0, the display does not shift.

During DDRAM write, when bit S = 1 and bit I\_D = 0, the entire display shifts to the right; when bit S = 1 and bit I\_D = 1, the entire display shifts to the left.

Thus it appears as if the cursor stands still and the display moves. The display does not shift when reading from the DDRAM, or when writing to or reading from the CGRAM.

### 10.2.2.4 Display\_ctl instructions

Table 20. Display\_ctl bit description

Bit	Symbol	Value	Description
RS	-	0	see <a href="#">Table 11</a>
R/W	-	0	
7 to 3	-	00001	fixed value
2	D		<b>display on or off</b>
		0	display is off; chip is in power-down mode
		1	display is on
1	C		<b>cursor on or off</b>
		0	cursor is off
		1	cursor is on
0	B		<b>character blink on or off</b>
		0	character blink is off
		1	character blink is on

**Bit D:** The display is on when bit D = 1 and off when bit D = 0. Display data in the DDRAM is not affected and can be displayed immediately by setting bit D = 1.

When the display is off (bit D = 0) the chip is in partial power-down mode:

- The LCD outputs are connected to V<sub>SS</sub>
- The V<sub>LCD</sub> generator and bias generator are turned off

Three oscillator cycles are required after sending the 'display off' instruction to ensure all outputs are at V<sub>SS</sub>, afterwards the oscillator can be stopped. If the oscillator is running during partial power-down mode ('display off') the chip can still execute instructions. Even lower current consumption is obtained by inhibiting the oscillator (pin OSC to V<sub>SS</sub>).

To ensure I<sub>DD</sub> < 1 μA:

- the parallel bus ports DB7 to DB0 should be connected to V<sub>DD</sub>
- pins RS and  $\overline{R/W}$  should be connected to V<sub>DD</sub> or left open-circuit
- pin PD should be connected to V<sub>DD</sub>

Recovery from power-down mode:

- pin PD should be connected back to V<sub>SS</sub>
- if necessary pin OSC should be connected back to V<sub>DD</sub>
- a Display\_ctl instruction with bit D = 1 should be sent

**Bit C:** The cursor is displayed when bit C = 1 and inhibited when bit C = 0. Even if the cursor disappears, bit I\_D and bit S (see [Section 10.2.2.3](#)) remain in operation during display data write. The cursor is displayed using 5 dots in the 8th line (see [Figure 17](#)).

**Bit B:** The character, indicated by the cursor, blinks when bit B = 1. The character blink is displayed by switching between display characters and all dots on with a frequency of

$$f_{blink} = \frac{f_{osc}}{52224}$$

### 10.2.2.5 Curs\_disp\_shift

Table 21. Curs\_disp\_shift bit description

Bit	Symbol	Value	Description
RS	-	0	see <a href="#">Table 11</a>
$\overline{R/W}$	-	0	
7 to 4	-	0001	fixed value
3	SC		<b>cursor move or display shift</b>
		0	move cursor
		1	shift display
2	RL		<b>shift or move to the right or left</b>
		0	left shift or move
		1	right shift or move
1 to 0	-	00	fixed value

**Bits SC and RL:** Curs\_disp\_shift moves the cursor position or the display to the right or left without writing or reading display data. This function is used to correct a character or move the cursor through the display.

In 2-line displays, the cursor moves to the next line when it passes the last position (40) of the line. When the displayed data is shifted repeatedly all lines shift at the same time; displayed characters do not shift into the next line.

The address counter content does not change if the only action performed is shift display (SC = 1) but increments or decrements with the shift cursor (SC = 0).

### 10.2.2.6 Set\_CGRAM

Table 22. Set\_CGRAM bit description

Bit	Symbol	Value	Description
RS	-	0	see <a href="#">Table 11</a>
R/W	-	0	
7 to 6	-	01	fixed value
5 to 0	ACG	000000 to 111111	set CGRAM address

**Set\_CGRAM:** Sets the CGRAM address bits ACG[5:0] into the address counter. Data can then be written to or read from the CGRAM.

**Remark:** The CGRAM address uses the same address register as the DDRAM address. This register consists of 7 bits. But with the Set\_CGRAM command, only bit 5 to bit 0 are set. Bit 6 can be set using the Set\_DDRAM command first, or by using the auto-increment feature during CGRAM write. All bits 6 to 0 can be read using the BF\_AC instruction.

When writing to the lower part of the CGRAM, ensure that bit 6 of the address is not set (e.g. by an earlier DDRAM write).

### 10.2.2.7 Set\_DDRAM

Table 23. Set\_DDRAM bit description

Bit	Symbol	Value	Description
RS	-	0	see <a href="#">Table 11</a>
R/W	-	0	
7	-	1	fixed value
6 to 0	ADD	0000000 to 1111111	set DDRAM address

**Set\_DDRAM:** Sets the DDRAM address bits ADD[6:0] into the address counter. Data can then be written to or read from the DDRAM.

## 10.2.3 Extended instructions (bit H = 1)

### 10.2.3.1 Screen\_conf

Table 24. Screen\_conf bit description

Bit	Symbol	Value	Description
RS	-	0	see <a href="#">Table 11</a>
R/W	-	0	
7 to 1	-	0000001	fixed value
0	L		<b>screen configuration</b>
		0	split screen standard connection
		1	split screen mirrored connection

#### Screen\_conf:

- If bit L = 0, then the two halves of a split screen are connected in a standard way i.e. column 1/81, 2/82 to 80/160.
- If bit L = 1, then the two halves of a split screen are connected in a mirrored way i.e. column 1/160, 2/159 to 80/81. This allows single layer PCB or glass layout.

### 10.2.3.2 Disp\_conf

Table 25. Disp\_conf bit description

Bit	Symbol	Value	Description
RS	-	0	see <a href="#">Table 11</a>
R/W	-	0	
7 to 2	-	000001	fixed value
1	P		<b>display column configuration</b>
		0	column data: left to right; column data is displayed from column 1 to column 80
		1	column data: right to left; column data is displayed from column 80 to column 1
0	Q		<b>display row configuration</b>
		0	row data: top to bottom; row data is displayed from row 1 to row 16 and icon row data in row 17 and row 18 in single line mode (SL = 1) row data is displayed from row 1 to row 8 and icon row data in row 17
		1	row data: bottom to top; row data is displayed from row 16 to row 1 and icon row data in row 18 and row 17 in single line mode (SL = 1) row data is displayed from row 8 to row 1 and icon row data in row 17

**Bit P:** The P bit is used to flip the display left to right by mirroring the column data, as shown in [Figure 19](#). This allows the display to be viewed from behind instead of front and enhances the flexibility in the assembly of equipment and avoids complicated data manipulation within the controller.

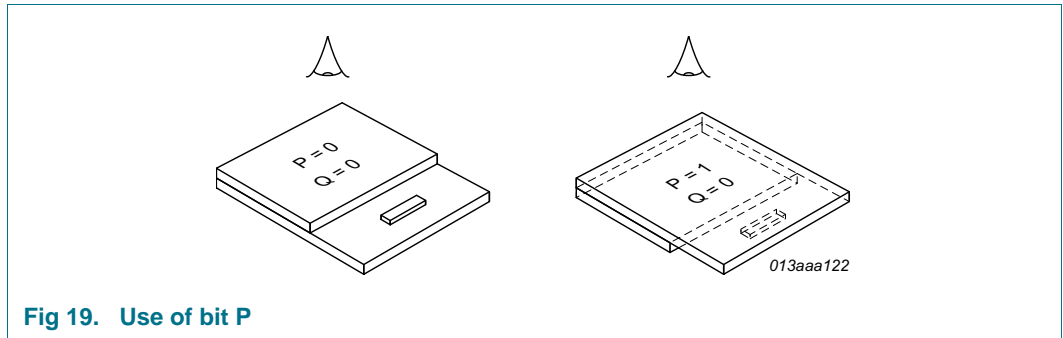

Fig 19. Use of bit P

**Bit Q:** The Q bit flips the display top to bottom by mirroring the row data, as shown in [Figure 20](#).

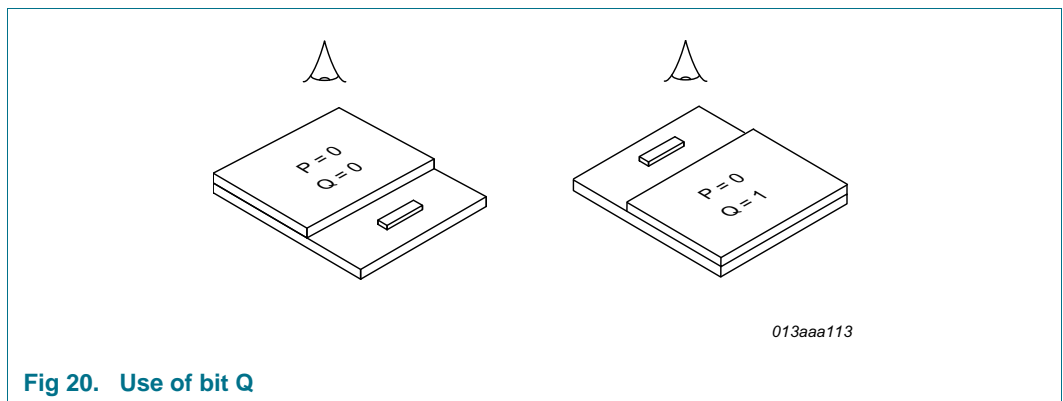

Fig 20. Use of bit Q

**Combination of bit P and bit Q:** A combination of P and Q allows the display to be rotated horizontally and vertically by 180 degree, as shown in [Figure 21](#). This is useful for viewing the display from the opposite edge.

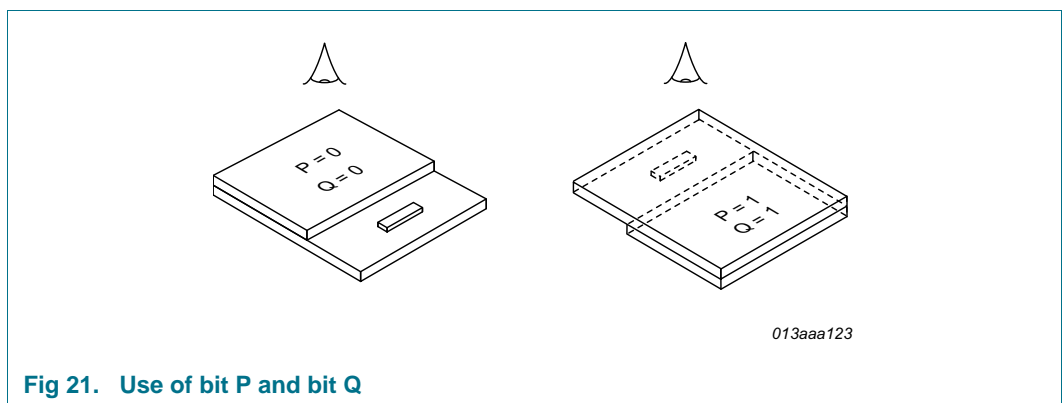

Fig 21. Use of bit P and bit Q

### 10.2.3.3 Icon\_ctl

Table 26. Icon\_ctl bit description

Bit	Symbol	Value	Description
RS	-	0	see <a href="#">Table 11</a>
R/W	-	0	
7 to 3	-	00001	fixed value

Table 26. Icon\_ctl bit description ...continued

Bit	Symbol	Value	Description
2	IM		<b>icon mode</b>
		0	character mode, full display
		1	icon mode, only icons displayed
1	IB		<b>icon blink</b>
		0	icon blink disabled
		1	icon blink enabled
0	DM		<b>direct mode</b>
		0	off
		1	on

The PCF2119x can drive up to 160 icons. See [Figure 22](#) and [Figure 23](#) for CGRAM to icon mapping.

**Bit IM:** When bit IM = 0, the chip is in character mode. In the character mode characters and icons are driven (multiplex drive mode 1:18 or 1:9). The V<sub>LCD</sub> generator, if used, produces the V<sub>LCDOUT</sub> voltage programmed with register V<sub>A</sub>.

When bit IM = 1, the chip is in icon mode. In the icon mode only the icons are driven (multiplex drive mode 1:2). The V<sub>LCD</sub> generator, if used, produces the V<sub>LCDOUT</sub> voltage as programmed with register V<sub>B</sub>.

Table 27. Normal/icon mode operation

Bit IM	Mode	V <sub>LCDOUT</sub>
0	character mode	generated from V <sub>A</sub>
1	icon mode	generated from V <sub>B</sub>

**Bit IB:** Icon blink control is independent of the cursor/character blink function.

When bit IB = 0, the icon blink is disabled. Icon data is stored in CGRAM character 0 to 3 (4 × 8 × 5 = 160 bits for 160 icons).

When bit IB = 1, the icon blink is enabled. In this case each icon is controlled by two bits. Blink consists of two half phases (corresponding to the cursor on and off phases called even and odd phases hereafter).

Icon states for the even phase are stored in CGRAM characters 0 to 3 (4 × 8 × 5 = 160 bits for 160 icons). These bits also define icon state when icon blink is not used (see [Table 28](#)).

Icon states for the odd phase are stored in CGRAM character 4 to 7 (another 160 bits for the 160 icons). When icon blink is disabled CGRAM characters 4 to 7 may be used as normal CGRAM characters.

Table 28. Blink effect for icons and cursor character blink

Parameter	Even phase	Odd phase
cursor character blink	block (all on)	normal (display character)
icons	state 1; CGRAM character 0 to 3	state 2; CGRAM character 4 to 7



Fig 22. CGRAM to icon mapping (a)

icon no.	phase	ROW/COL	character codes								CGRAM address								CGRAM data				icon view		
			7	6	5	4	3	2	1	0	MSB	LSB				MSB	LSB				MSB	LSB			
1-5	even	17/1-5	0	0	0	0	0	0	0	0	0	0	0	0	0	0	0	0	0	1	0	1	0	1	
6-10	even	17/6-10	0	0	0	0	0	0	0	0	0	0	0	0	0	0	0	0	1	0	1	0	1	0	
11-15	even	17/11-15	0	0	0	0	0	0	0	0	0	0	0	0	0	0	1	0	0	0	1	1	1	0	
76-80	even	17/76-80	0	0	0	0	0	0	0	0	1	0	0	0	1	1	1	1	1	1	1	1	1	1	
81-85	even	18/1-5	0	0	0	0	0	0	0	1	0	0	0	1	0	0	0	0	0	1	1	0	0	0	
156-160	even	18/76-80	0	0	0	0	0	0	0	1	1	0	0	1	1	1	1	1	1	1	1	1	0	1	
1-5	odd (blink)	17/1-5	0	0	0	0	0	0	1	0	0	0	1	0	0	0	0	0	0	0	0	0	0	0	
156-160	odd (blink)	18/76-80	0	0	0	0	0	0	1	1	1	0	1	1	1	1	1	1	1	0	0	1	1	0	

mgk999

CGRAM data: logic 1 of a data bit turns the icon on and logic 0 turns the icon off.

Character codes: bits 0 to 3 define the icon state when icon blink is disabled or during the even phase when icon blink is enabled. Bits 4 to 7 define the icon state during the odd phase when icon blink is enabled (not used for icons when icon blink is disabled)

Fig 23. CGRAM to icon mapping (b)

**Bit DM:** When DM = 0, the chip is not in the direct mode. Either the internal  $V_{LCD}$  generator or an external voltage may be used to achieve  $V_{LCD}$ .

When DM = 1, the chip is in direct mode. The internal  $V_{LCD}$  generator is turned off and the output  $V_{LCDOUT}$  is directly connected to  $V_{DD2}$  (i.e. the  $V_{LCD}$  generator supply voltage).

**Remark:** In direct mode, no external  $V_{LCD}$  is possible.

The direct mode can be used to reduce the current consumption when the required output voltage  $V_{LCDOUT}$  is close to the  $V_{DD2}$  supply voltage. This can be the case in icon mode or in MUX 1:9 (depending on LCD liquid properties).

### 10.2.3.4 Temp\_ctl

Table 29. Temp\_ctl bit description

Bit	Symbol	Value	Description
RS	-	0	see <a href="#">Table 11</a>
R/W	-	0	
7 to 2	-	000100	fixed value
1 to 0	TC[1:0]	00 to 11	<b>temperature coefficient</b>

The bit-field TC[1:0] selects the temperature coefficient for the internally generated  $V_{LCDOUT}$  (see [Table 30](#)).

Table 30. TC[1:0] selection of  $V_{LCD}$  temperature coefficient

TC[1:0]	Typical value	Description
00	-0.16 %/K	$V_{LCD}$ temperature coefficient 0 (default value)
10	-0.18 %/K	$V_{LCD}$ temperature coefficient 1
01	-0.21 %/K	$V_{LCD}$ temperature coefficient 2
11	-0.24 %/K	$V_{LCD}$ temperature coefficient 3

### 10.2.3.5 HV\_gen

Table 31. HV\_gen bit description

Bit	Symbol	Value	Description
RS	-	0	see <a href="#">Table 11</a>
R/W	-	0	
7 to 2	-	010000	fixed value
1 to 0	S[1:0]	00 to 11	<b>voltage multiplier</b>

A software configurable voltage multiplier is incorporated in the  $V_{LCD}$  generator and can be set via the HV\_gen command. The voltage multiplier control can be used to reduce current consumption by disconnecting internal voltage multiplier stages, depending on the required  $V_{LCDOUT}$  output voltage (see [Table 32](#)).

Table 32. Voltage multiplier control bits

S[1:0]	Description
00	set $V_{LCD}$ generator stages to 1 (2 × voltage multiplier)
01	set $V_{LCD}$ generator stages to 2 (3 × voltage multiplier)
10	set $V_{LCD}$ generator stages to 3 (4 × voltage multiplier)
11	do not use

### 10.2.3.6 VLCD\_set

Table 33. VLCD\_set bit description

Bit	Symbol	Value	Description
RS	-	0	see <a href="#">Table 11</a>
R/W	-	0	
7	-	1	fixed value



Table 33. VLCD\_set bit description ...continued

Bit	Symbol	Value	Description
6	V		<b>set register <math>V_A</math> or <math>V_B</math></b>
		0	set register $V_A$
		1	set register $V_B$
5 to 0	$V_A$ or $V_B$	000000 to 111111	<b>factor for calculating <math>V_{LCD}</math></b>

The  $V_{LCD}$  value is calculated with the [Equation 2 on page 9](#). The multiplication factor is programmed by instruction. Two on-chip registers ( $V_A$  and  $V_B$ ) hold the multiplication factor for the character mode and the icon mode, respectively. The generated  $V_{LCDOUT}$  value is independent of  $V_{DD}$ , allowing battery operation of the chip.

$V_x$  programming:

1. Send Function\_set instruction with bit H = 1.
2. Send VLCD\_set instruction to write to the voltage register:
  - a. Bit 7 = 1 and bit 6 = 0: bit 5 to bit 0 are the multiplication factor for  $V_{LCD}$  of character mode ( $V_A$ ).
  - b. Bit 7 = 1 and bit 6 = 1: bit 5 to bit 0 are the multiplication factor for  $V_{LCD}$  of icon mode ( $V_B$ ).
  - c. Bit 5 to bit 0 = 0 switches  $V_{LCD}$  generator off (when selected).
  - d. During 'display off'/power-down the  $V_{LCD}$  generator is also disabled.
3. Send Function\_set instruction with bit H = 0 to resume normal programming.

## 11. Basic architecture

### 11.1 Parallel interface

The PCF2119x can send data in either two 4-bit operations or one 8-bit operation and can thus interface to 4-bit or 8-bit microcontrollers.

In 8-bit mode data is transferred as 8-bit bytes using the 8 ports DB7 to DB0. Three further control lines E, RS and R/W are required.

In 4-bit mode data is transferred in two cycles of 4 bits each using ports DB7 to DB4 for the transaction. The higher order bits (corresponding to range of bit 7 to bit 4 in 8-bit mode) are sent in the first cycle and the lower order bits (bit 3 to bit 0 in 8-bit mode) in the second cycle. Data transfer is complete after two 4-bit data transfers. It should be noted that two cycles are also required for the busy flag check. 4-bit operation is selected by instruction (see [Figure 24](#) to [Figure 26](#) for examples of bus protocol).

In 4-bit mode, ports DB3 to DB0 must be left open-circuit. They are pulled up to  $V_{DD}$  internally.



Fig 24. 4-bit transfer example

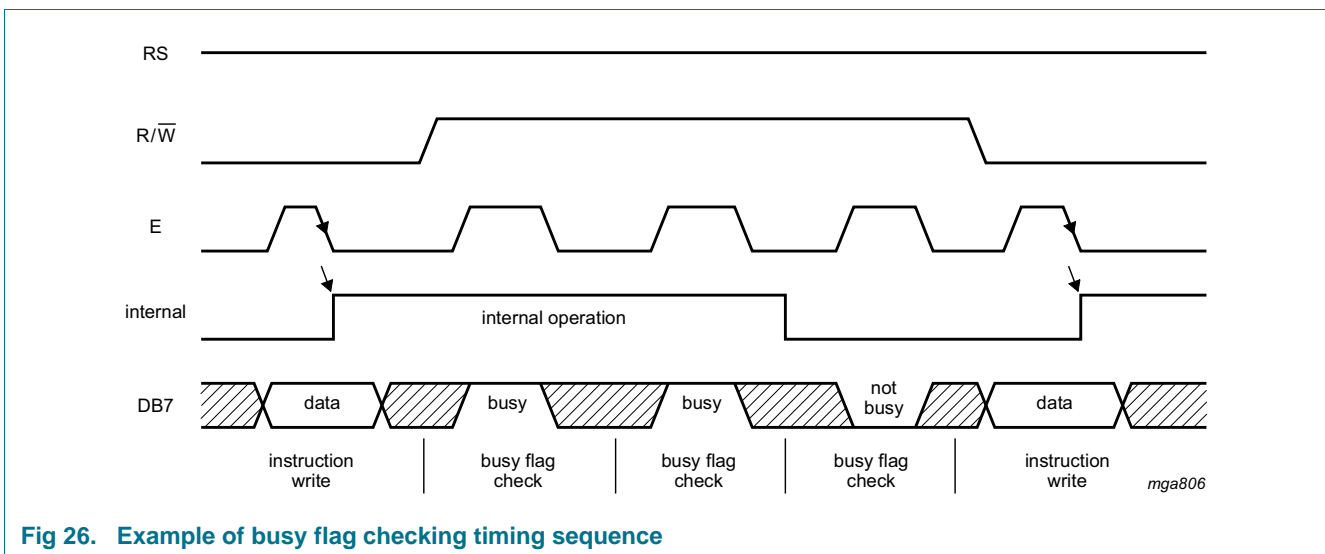

### 11.2 I<sup>2</sup>C-bus interface

The I<sup>2</sup>C-bus is for bidirectional, two-line communication between different ICs or modules. The two lines are the Serial DAta line (SDA) and the Serial CLock line (SCL). Both lines must be connected to a positive supply via pull-up resistors. Data transfer may be initiated only when the bus is not busy.

Each byte of eight bits is followed by an acknowledge bit. A slave receiver which is addressed must generate an acknowledge after the reception of each byte.

Also a master receiver must generate an acknowledge after the reception of each byte that has been clocked out of the slave transmitter.

The device that acknowledges must pull-down the SDA line during the acknowledge clock pulse, so that the SDA line is stable LOW during the HIGH period of the acknowledge related clock pulse (set-up and hold times must be taken into consideration).

A master receiver must signal an end of data to the transmitter by not generating an acknowledge bit on the last byte that has been clocked out of the slave. In this event the transmitter must leave the data line HIGH to enable the master to generate a STOP condition.

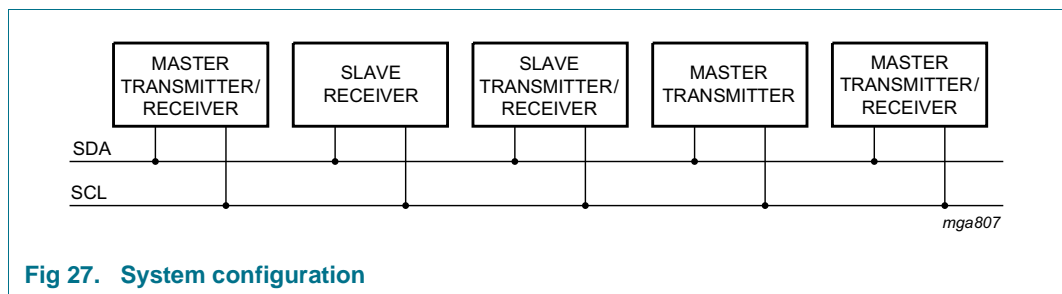

Fig 27. System configuration

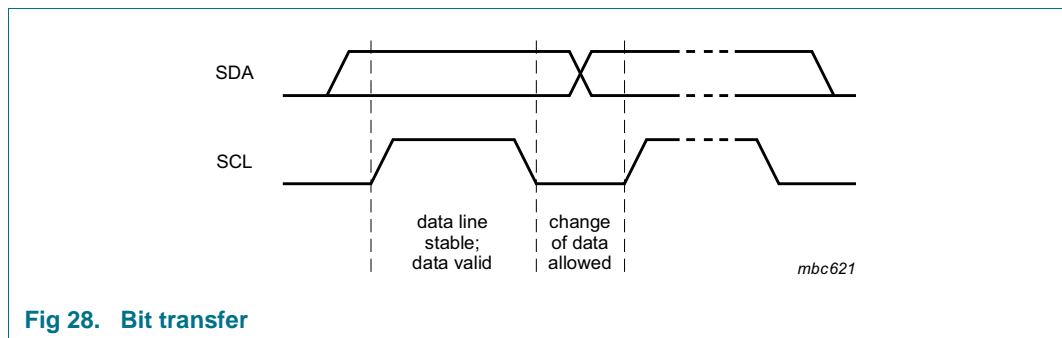

Fig 28. Bit transfer

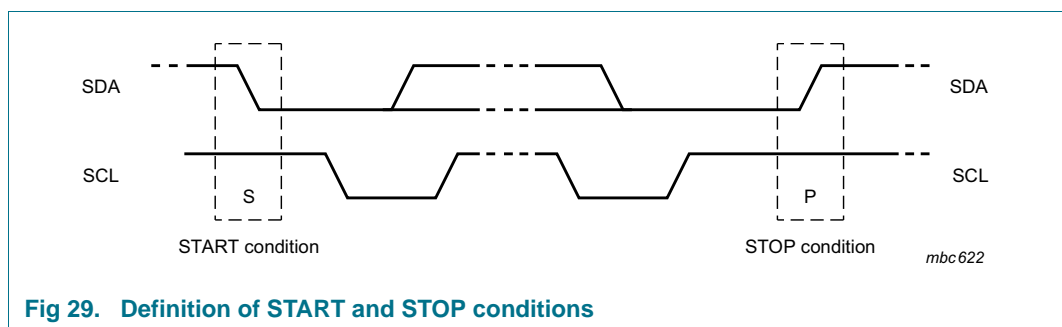

Fig 29. Definition of START and STOP conditions



Fig 30. Acknowledgement on the I<sup>2</sup>C-bus

### 11.2.1 I<sup>2</sup>C-bus protocol

Two I<sup>2</sup>C-bus slave addresses (0111 010 and 0111 011) are reserved for the PCF2119x. The entire I<sup>2</sup>C-bus slave address byte is shown in [Table 34](#).

Table 34. I<sup>2</sup>C slave address byte

Bit	Slave address							0
	7	6	5	4	3	2	1	
	MSB							LSB
	0	1	1	1	0	1	SA0	R/W

Bit 1 of the slave address byte, that a PCF2119x will respond to, is defined by the level tied to its SA0 input ( $V_{SS}$  for logic 0 and  $V_{DD}$  for logic 1).

Before any data is transmitted on the I<sup>2</sup>C-bus, the device which should respond is addressed first. The addressing is always carried out with the first byte transmitted after the START procedure.

The I<sup>2</sup>C-bus configuration for the different PCF2119x read and write cycles is shown in [Figure 31](#) to [Figure 33](#).

The slow down feature of the I<sup>2</sup>C-bus protocol (receiver holds SCL line LOW during internal operations) is not used in the PCF2119x.

### 11.2.2 I<sup>2</sup>C-bus definitions

Definitions:

- Transmitter: the device which sends the data to the bus.
- Receiver: the device which receives the data from the bus.
- Master: the device which initiates a transfer, generates clock signals and terminates a transfer.
- Slave: the device addressed by a master.
- Multi-master: more than one master can attempt to control the bus at the same time without corrupting the message.

- Arbitration: procedure to ensure that if more than one master simultaneously tries to control the bus, only one is allowed to do so and the message is not corrupted.
- Synchronization: procedure to synchronize the clock signals of two or more devices.



Fig 31. Master transmits to slave receiver; write mode



Last data byte is a dummy byte (may be omitted).

Fig 32. Master reads after setting word address; writes word address, set RS; Read\_data



Fig 33. Master reads slave immediately after first byte; read mode (RS previously defined)

### 11.3 Safety notes

**CAUTION**



This device is sensitive to ElectroStatic Discharge (ESD). Observe precautions for handling electrostatic sensitive devices. Such precautions are described in the *ANSI/ESD S20.20*, *IEC/ST 61340-5*, *JESD625-A* or equivalent standards.

**CAUTION**



Static voltages across the liquid crystal display can build up when the LCD supply voltage ( $V_{LCD}$ ) is on while the IC supply voltage ( $V_{DD}$ ) is off, or vice versa. This may cause unwanted display artifacts. To avoid such artifacts,  $V_{LCD}$  and  $V_{DD}$  must be applied or removed together.

**CAUTION**



Semiconductors are light sensitive. Exposure to light sources can cause the IC to malfunction. The IC must be protected against light. The protection must be applied to all sides of the IC.

## 12. Internal circuitry

Table 35. Device protection circuits

Symbol	Pin	Internal circuit
$V_{DD1}$	1 to 6	 013aaa169
$V_{DD2}$	7 to 14	 013aaa170
$V_{DD3}$	15 to 18	 013aaa171
$V_{SS1}$	22 to 29	 013aaa172
$V_{SS2}$	30 to 35	
$V_{LCDSENSE}$	36	 013aaa173
$V_{LCDIN}$	44 to 49	
$V_{LCDOUT}$	37 to 43	
SCL	151 to 152	
SDA	156 to 157	 013aaa174
OSC	168	
PD	155	
POR	154	
T1	20	
T2	21	
T3	153	
E	19	
RS	159	 013aaa175
$R/\overline{W}$	158	
DB0 to DB7	160 to 167	
R1 to R18	58, 57 to 51, 142 to 149, 59, 100, 141	
C1 to C80	140 to 101, 99 to 60	



## 13. Limiting values

**Table 36. Limiting values**

*In accordance with the Absolute Maximum Rating System (IEC 60134).*

Symbol	Parameter	Conditions	Min	Max	Unit
V <sub>DD1</sub>	supply voltage 1	logic	-0.5	+6.5	V
V <sub>DD2</sub>	supply voltage 2	V <sub>LCD</sub> generator	-0.5	+4.5	V
V <sub>DD3</sub>	supply voltage 3				
V <sub>LCD</sub>	LCD supply voltage		-0.5	+7.5	V
V <sub>I</sub>	input voltage	V <sub>DD</sub> related	-0.5	+6.5	V
		V <sub>LCD</sub> related	-0.5	+7.5	V
I <sub>I</sub>	input current	DC current [1]	-10	+10	mA
I <sub>O</sub>	output current	DC current [1]	-10	+10	mA
I <sub>DD</sub>	supply current		-50	+50	mA
I <sub>SS</sub>	ground supply current		-50	+50	mA
I <sub>DD(LCD)</sub>	LCD supply current		-50	+50	mA
P <sub>tot</sub>	total power dissipation		-	400	mW
P <sub>o</sub>	output power	dissipation per output	-	100	mW
V <sub>ESD</sub>	electrostatic discharge voltage	HBM [2]	-	±3000	V
		MM [3]	-	±300	V
I <sub>Iu</sub>	latch-up current	[4]	-	200	mA
T <sub>stg</sub>	storage temperature	[5]	-65	+150	°C
T <sub>amb</sub>	ambient temperature	operating device	-40	+85	°C

[1] For all diode protected input and output pins.

[2] Pass level; Human Body Model (HBM) according to [Ref. 7 "JESD22-A114"](#).

[3] Pass level; Machine Model (MM), according to [Ref. 8 "JESD22-A115"](#).

[4] Pass level; latch-up testing according to [Ref. 9 "JESD78"](#) at maximum ambient temperature (T<sub>amb(max)</sub>).

[5] According to the store and transport requirements (see [Ref. 12 "UM10569"](#)) the devices have to be stored at a temperature of +8 °C to +45 °C and a humidity of 25 % to 75 %.

## 14. Static characteristics

**Table 37. Static characteristics**

$V_{DD1} = 1.5\text{ V to }5.5\text{ V}$ ;  $V_{DD2} = V_{DD3} = 2.2\text{ V to }4.0\text{ V}$ ;  $V_{SS} = 0\text{ V}$ ;  $V_{LCD} = 2.2\text{ V to }6.5\text{ V}$ ;  $T_{amb} = -40\text{ }^{\circ}\text{C to }+85\text{ }^{\circ}\text{C}$ ; unless otherwise specified.

Symbol	Parameter	Conditions	Min	Typ	Max	Unit
<b>Supplies</b>						
$V_{DD1}$	supply voltage 1	logic	1.5	-	5.5	V
$V_{DD2}$	supply voltage 2	internal $V_{LCD}$ generation;	2.2	-	4.0	V
$V_{DD3}$	supply voltage 3	$V_{LCD} > V_{DD2} = V_{DD3}$				
$V_{LCD}$	LCD supply voltage	pins $V_{LCD}$ , $V_{LCDIN}$ , $V_{LCDOUT}$	2.2	-	6.5	V
Ground supply current using external $V_{LCD}$ [1]						
$I_{SS}$	ground supply current		-	70	120	$\mu\text{A}$
		$V_{DD} = 3\text{ V}$ ; $V_{LCD} = 5\text{ V}$ [2]	-	35	80	$\mu\text{A}$
		icon mode; $V_{DD} = 3\text{ V}$ ; $V_{LCD} = 2.5\text{ V}$ [2]	-	25	45	$\mu\text{A}$
		power-down mode; $V_{DD} = 3\text{ V}$ ; $V_{LCD} = 2.5\text{ V}$ ; DB7 to DB0, RS and $R/\overline{W} = 1$ ; OSC = 0; PD = 1	-	0.5	5	$\mu\text{A}$
Ground supply current using internal $V_{LCD}$ [1][3]						
$I_{SS}$	ground supply current		-	190	400	$\mu\text{A}$
		$V_{DD} = 3\text{ V}$ ; $V_{LCD} = 5\text{ V}$ [2]	-	135	400	$\mu\text{A}$
		icon mode; $V_{DD} = 2.5\text{ V}$ ; $V_{LCD} = 2.5\text{ V}$ [2]	-	85	-	$\mu\text{A}$
<b>Logic</b>						
$V_I$	input voltage		-0.5	-	$V_{DD1} + 0.5$	V
$V_{IL}$	LOW-level input voltage		$V_{SS1}$	-	$0.3V_{DD1}$	V
$V_{IH}$	HIGH-level input voltage		$0.7V_{DD1}$	-	$V_{DD1}$	V
Oscillator input; pin OSC						
$V_{IL}$	LOW-level input voltage		$V_{SS1}$	-	$V_{DD1} - 1.2$	V
$V_{IH}$	HIGH-level input voltage		$V_{DD1} - 0.1$	-	$V_{DD1}$	V
Data bus; pins DB7 to DB0						
$I_{OL}$	LOW-level output current	output sink current; $V_{OL} = 0.4\text{ V}$ ; $V_{DD1} = 5\text{ V}$	1.6	4	-	mA
$I_{OH}$	HIGH-level output current	output source current; $V_{OH} = 4\text{ V}$ ; $V_{DD1} = 5\text{ V}$	1	8	-	mA
$I_{pu}$	pull-up current	$V_I = V_{SS1}$	0.04	0.15	1	$\mu\text{A}$
$I_L$	leakage current	$V_I = V_{DD1, 2, 3}$ or $V_{SS1, 2}$	-1	-	+1	$\mu\text{A}$
<b>I<sup>2</sup>C-bus; pins SDA and SCL</b>						
Inputs: pins SDA and SCL						
$V_I$	input voltage	[4]	-0.5	-	5.5	V
$V_{IL}$	LOW-level input voltage		0	-	$0.3V_{DD1}$	V
$V_{IH}$	HIGH-level input voltage		$0.7V_{DD1}$	-	5.5	V
$I_{LI}$	input leakage current	$V_I = V_{DD1, 2, 3}$ or $V_{SS1, 2}$	-1	-	+1	$\mu\text{A}$

**Table 37. Static characteristics ...continued**

$V_{DD1} = 1.5\text{ V to }5.5\text{ V}$ ;  $V_{DD2} = V_{DD3} = 2.2\text{ V to }4.0\text{ V}$ ;  $V_{SS} = 0\text{ V}$ ;  $V_{LCD} = 2.2\text{ V to }6.5\text{ V}$ ;  $T_{amb} = -40\text{ }^{\circ}\text{C to }+85\text{ }^{\circ}\text{C}$ ; unless otherwise specified.

Symbol	Parameter	Conditions	Min	Typ	Max	Unit
$C_i$	input capacitance		-	5	-	pF
Output: pin SDA						
$I_{OL}$	LOW-level output current	output sink current				
		$V_{OL} = 0.4\text{ V}$ ; $V_{DD1} > 2\text{ V}$	3	-	-	mA
		$V_{OL} = 0.2\text{ V}$ ; $V_{DD1} < 2\text{ V}$	2	-	-	mA
LCD outputs						
$R_O$	output resistance	row output, pins R1 to R18 <a href="#">[5]</a>	-	10	30	k $\Omega$
		column output, pins C1 to C80 <a href="#">[5]</a>	-	15	40	k $\Omega$
$\Delta V_{bias}$	bias voltage variation	on pins R1 to R18 and C1 to C80 <a href="#">[6]</a>	-	20	130	mV
$\Delta V_{LCD}$	LCD voltage variation	$T_{amb} = 25\text{ }^{\circ}\text{C}$ <a href="#">[3]</a>				
		$V_{LCD} < 3\text{ V}$	-	-	160	mV
		$V_{LCD} < 4\text{ V}$	-	-	200	mV
		$V_{LCD} < 5\text{ V}$	-	-	260	mV
		$V_{LCD} < 6\text{ V}$	-	-	340	mV

- [1] LCD outputs are open-circuit; inputs at  $V_{DD}$  or  $V_{SS}$ ; bus inactive.
- [2]  $T_{amb} = 25\text{ }^{\circ}\text{C}$ ;  $f_{osc(ext)} = 200\text{ kHz}$ .
- [3] LCD outputs are open-circuit;  $V_{LCD}$  generator is on; load current  $I_{LCD} = 5\text{ }\mu\text{A}$ .
- [4] The I<sup>2</sup>C-bus interface of PCF2119x is 5 V tolerant.
- [5] Resistance of output pins (R1 to R18 and C1 to C80) with a load current of 10  $\mu\text{A}$ ; outputs measured one at a time; external LCD supply  $V_{LCD} = 3\text{ V}$ ;  $V_{DD1} = V_{DD2} = V_{DD3} = 3\text{ V}$ .
- [6] LCD outputs open-circuit; external LCD supply.

## 15. Dynamic characteristics

**Table 38. Dynamic characteristics**

$V_{DD1} = 1.5\text{ V to }5.5\text{ V}$ ;  $V_{DD2} = V_{DD3} = 2.2\text{ V to }4.0\text{ V}$ ;  $V_{SS} = 0\text{ V}$ ;  $V_{LCD} = 2.2\text{ V to }6.5\text{ V}$ ;  $T_{amb} = -40\text{ }^{\circ}\text{C to }+85\text{ }^{\circ}\text{C}$ ; unless otherwise specified.

Symbol	Parameter	Conditions	Min	Typ	Max	Unit
<b>Clock and oscillator</b>						
$f_{fr(LCD)}$	LCD frame frequency	internal clock; $V_{DD} = 5.0\text{ V}$	45	95	147	Hz
$f_{osc}$	oscillator frequency	not available at any pin	140	250	450	kHz
$f_{osc(ext)}$	external oscillator frequency		140	-	450	kHz
$t_{d(startup)(OSC)}$	start-up delay time on pin OSC	oscillator, after power-down <a href="#">[1]</a>	-	200	300	$\mu\text{s}$
<b>Timing characteristics of parallel interface</b> <a href="#">[2]</a>						
Write operation (writing data from microcontroller to PCF2119x); see <a href="#">Figure 34</a>						
$t_{cy(en)}$	enable cycle time		500	-	-	ns
$t_{w(en)}$	enable pulse width		220	-	-	ns
$t_{su(A)}$	address set-up time		50	-	-	ns
$t_{h(A)}$	address hold time		25	-	-	ns
$t_{su(D)}$	data input set-up time		60	-	-	ns
$t_{h(D)}$	data input hold time		25	-	-	ns
Read operation (reading data from PCF2119x to microcontroller); see <a href="#">Figure 35</a>						
$t_{cy(en)}$	enable cycle time		500	-	-	ns
$t_{w(en)}$	enable pulse width		220	-	-	ns
$t_{su(A)}$	address set-up time		50	-	-	ns
$t_{h(A)}$	address hold time		25	-	-	ns
$t_{d(DV)}$	data input valid delay time	$V_{DD1} > 2.2\text{ V}$	-	-	150	ns
		$V_{DD1} > 1.5\text{ V}$	-	-	250	ns
$t_{h(D)}$	data input hold time		20	-	100	ns
<b>Timing characteristics of I<sup>2</sup>C-bus interface</b> <a href="#">[2]</a> ; see <a href="#">Figure 36</a>						
$f_{SCL}$	SCL clock frequency		-	-	400	kHz
$t_{LOW}$	LOW period of the SCL clock		1.3	-	-	$\mu\text{s}$
$t_{HIGH}$	HIGH period of the SCL clock		0.6	-	-	$\mu\text{s}$
$t_{SU,DAT}$	data set-up time		100	-	-	ns
$t_{HD,DAT}$	data hold time		0	-	-	ns
$t_r$	rise time of both SDA and SCL signals	<a href="#">[1][3]</a>	$15 + 0.1 C_b$	-	300	ns
$t_f$	fall time of both SDA and SCL signals	<a href="#">[1][3]</a>	$15 + 0.1 C_b$	-	300	ns
$C_b$	capacitive load for each bus line		-	-	400	pF
$t_{SU,STA}$	set-up time for a repeated START condition		0.6	-	-	$\mu\text{s}$
$t_{HD,STA}$	hold time (repeated) START condition		0.6	-	-	$\mu\text{s}$

**Table 38. Dynamic characteristics ...continued**

$V_{DD1} = 1.5\text{ V to }5.5\text{ V}$ ;  $V_{DD2} = V_{DD3} = 2.2\text{ V to }4.0\text{ V}$ ;  $V_{SS} = 0\text{ V}$ ;  $V_{LCD} = 2.2\text{ V to }6.5\text{ V}$ ;  $T_{amb} = -40\text{ }^{\circ}\text{C to }+85\text{ }^{\circ}\text{C}$ ; unless otherwise specified.

Symbol	Parameter	Conditions	Min	Typ	Max	Unit
$t_{SU,STO}$	set-up time for STOP condition		0.6	-	-	$\mu\text{s}$
$t_{SP}$	pulse width of spikes that must be suppressed by the input filter		-	-	50	ns
$t_{BUF}$	bus free time between a STOP and START condition		1.3	-	-	$\mu\text{s}$

- [1] Tested on sample base.
- [2] All timing values are valid within the operating supply voltage and ambient temperature range and are referenced to  $V_{IL}$  and  $V_{IH}$  with an input voltage swing of  $V_{SS}$  to  $V_{DD}$ .
- [3]  $C_b$  = total capacitance of one bus line in pF.



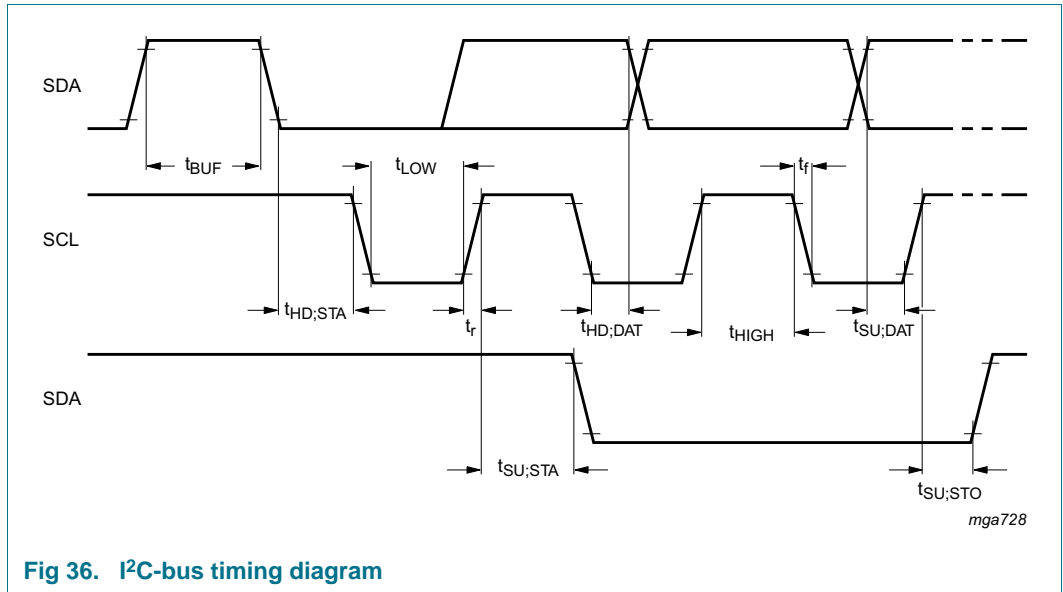

Fig 36. I<sup>2</sup>C-bus timing diagram

## 16. Application information

### 16.1 General application information

Experience showed that the external capacitors ( $C_{ext}$ ) in an application should be

- from pins  $V_{LCD}$  to  $V_{SS} \geq 100$  nF and
- for pins  $V_{DD}$  to  $V_{SS} \geq 470$  nF.

Higher capacitor values are recommended for ripple reduction, but depending on the application lower values may also lead to a good optical performance. The most suitable capacitor values can be found by testing the application and can be applied as long as they do not violate the specifications given in [Section 13](#) to [Section 15](#). The capacitors should be placed as close as possible to the display connections on the PCB.

For COG applications the recommended ITO track resistance is to be minimized for the I/O and supply connections. Optimized values for these tracks are below 50  $\Omega$  for the supply and below 100  $\Omega$  for the I/O connections. Higher track resistance reduce performance and increase current consumption. To avoid accidental triggering of Power-On Reset (POR) (especially in COG applications), the supplies must be adequately decoupled. Depending on power supply quality,  $V_{DD1}$  may have to be risen above the specified minimum.

When external LCD supply voltage is supplied,  $V_{LCDOUT}$  should be left open-circuit to avoid any stray current, and  $V_{LCDIN}$  must be connected to  $V_{LCDSENSE}$ .

The PCF2119x I<sup>2</sup>C-bus interface is compatible with systems, where the I<sup>2</sup>C pull-up resistors are connected to a 5 V  $\pm 10$  % supply.

16.2 Power supply connections for internal  $V_{LCD}$  generation



16.3 Power supply connections for external  $V_{LCD}$  generation



**Remark:** When using an external  $V_{LCD}$ , the internal  $V_{LCD}$  generator **must never** be switched on and direct mode must be avoided otherwise damages will occur.

### 16.4 Information about $V_{LCD}$ connections

**$V_{LCDIN}$**  — This input is used for generating the 5 LCD bias levels. It is the power supply for the bias level buffers.

**$V_{LCDOUT}$**  — This is the  $V_{LCD}$  output if  $V_{LCD}$  is generated internally. In this case pin  $V_{LCDOUT}$  must be connected to  $V_{LCDIN}$  and to  $V_{LCDSENSE}$ . If  $V_{LCD}$  is generated externally,  $V_{LCDOUT}$  must be left unconnected.

**$V_{LCDSENSE}$**  — This input is used for the voltage multiplier’s regulation circuitry. When using the internal  $V_{LCD}$  generation, this pin must be connected to  $V_{LCDOUT}$  and  $V_{LCDIN}$ . When using an external  $V_{LCD}$  supply it must be connected to  $V_{LCDIN}$  only.

### 16.5 Reducing current consumption

Reducing current consumption can be achieved by one of the options given in [Table 39](#).

When  $V_{LCD}$  lies outside the  $V_{DD}$  range and must be generated, it is usually more efficient to use the on-chip  $V_{LCD}$  generator than an external regulator.

**Table 39. Reducing current consumption**

Original mode	Alternative mode
character mode	icon mode (control bit IM)
display on	display off (control bit D)
$V_{LCD}$ generator operating	direct mode
any mode	power-down mode (pin PD)

### 16.6 Charge pump characteristics

Typical graphs of the total power consumption of the PCF2119x using the internal charge pump are illustrated in [Figure 41](#), [Figure 42](#) and [Figure 43](#).

The graphs were obtained under the following conditions:

- $T_{amb} = 25\text{ °C}$
- $V_{DD1} = V_{DD2} = V_{DD3} = 2.2\text{ V}$  (minimum), 2.7 V (typical) and 4.0 V (maximum)
- Normal mode
- $f_{osc} =$  internal oscillator
- multiplex drive mode 1:18
- Typical current load for  $I_{LCD} = 10\text{ }\mu\text{A}$ .

For each multiplication factor there is a separate line. The line ends where it is not possible to get a higher voltage under its conditions (a higher multiplication factor is needed to get higher voltages).

Connecting different displays may result in different current consumption. This affects the efficiency and the optimum multiplication factor to be used to generate a certain output voltage.







16.7 Interfaces





16.8 Connections with LCD modules





Fig 47. Connecting PCF2119x with 1 × 32 character LCD

### 16.9 4-bit operation, 1-line display using external reset

The program must set functions prior to a 4-bit operation (see [Table 40](#)). When power is turned on, 8-bit operation is automatically selected and the PCF2119x attempts to perform the first write as an 8-bit operation. Since nothing is connected to ports DB0 to DB3, a rewrite is then required. However, since one operation is completed in two accesses of 4-bit operation, a rewrite is required to set the functions (see [Table 40](#) step 3). Thus, DB4 to DB7 of the Function\_set are written twice.

Table 40. 4-bit operation, 1-line display example; using external reset (character set 'A')

Step	Instruction						Display	Operation
	RS	R/W	DB7	DB6	DB5	DB4		
1	power supply on							initialized by the external reset; no display appears
2	Function_set							sets to 4-bit operation; in this instance operation is handled as 8-bit by initialization and only this instruction completes with one write
	0	0	0	0	1	0		
3	Function_set							sets to 4-bit operation, selects 1-line display and $V_{LCD} = V_0$ ; 4-bit operation starts from this point and resetting is needed
	0	0	0	0	1	0		
	0	0	0	0	0	0		
4	Display_ctl							turns display and cursor on; entire display is blank after initialization
	0	0	0	0	0	0		
	0	0	1	1	1	0		
5	Entry_mode_set							sets mode to increment the address by 1 and to shift the cursor to the right at the time of write to the DDRAM or CGRAM; display is not shifted
	0	0	0	0	0	0		
	0	0	0	1	1	0		
6	Write_data to CGRAM/DDRAM							writes 'P'; the DDRAM has already been selected by initialization at power-on; the cursor is incremented by 1 and shifted to the right
	1	0	0	1	0	1		
	1	0	0	0	0	0		

### 16.10 8-bit operation, 1-line display using external reset

[Table 41](#) and [Table 42](#) show an example of a 1-line display in 8-bit operation. The PCF2119x functions must be set by the Function\_set instruction prior to display. Since the DDRAM can store data for 80 characters, the RAM can be used for advertising displays

when combined with display shift operation. Since the display shift operation changes display position only and the DDRAM contents remain unchanged, display data entered first can be displayed when the Return\_home operation is performed.

**Table 41. 8-bit operation, 1-line display example; using external reset (character set 'A')**

Step	Instruction											Display	Operation
	RS	R/W	DB7	DB6	DB5	DB4	DB3	DB2	DB1	DB0			
1	power supply on												initialized by the external reset; no display appears
2	Function_set												sets to 8-bit operation, selects 1-line display and $V_{LCD} = V_0$
	0	0	0	0	1	1	0	0	0	0			
3	Display_ctl												turns on display and cursor; entire display is blank after initialization
	0	0	0	0	0	0	1	1	1	0	_		
4	Entry_mode_set												sets mode to increment the address by 1 and to shift the cursor to the right at the time of the write to the DDRAM/CGRAM; display is not shifted
	0	0	0	0	0	0	0	1	1	0	_		
5	Write_data to CGRAM/DDRAM												writes 'P'; the DDRAM has already been selected by initialization at power-on; the cursor is incremented by 1 and shifted to the right
	1	0	0	1	0	1	0	0	0	0	P_		
6	Write_data to CGRAM/DDRAM												writes 'H'
	1	0	0	1	0	0	1	0	0	0	PH_		
7 to 10						:						PHILIP_	writes 'ILIP'
11	Write_data to CGRAM/DDRAM												writes 'S'
	1	0	0	1	0	1	0	0	1	1	PHILIPS_		
12	Entry_mode_set												sets mode for display shift at the time of write
	0	0	0	0	0	0	0	1	1	1	PHILIPS_		
13	Write_data to CGRAM/DDRAM												writes space
	1	0	0	0	1	0	0	0	0	0	HILIPS _		
14	Write_data to CGRAM/DDRAM												writes 'M'
	1	0	0	1	0	0	1	1	0	1	ILIPS M_		
15 to 19						:						MICROK_	writes 'ICROK'
20	Write_data to CGRAM/DDRAM												writes 'O'
	1	0	0	1	0	0	1	1	1	1	MICROKO_		
21	Curs_disp_shift												shifts only the cursor position to the left
	0	0	0	0	0	1	0	0	0	0	MICROK $\circ$		
22	Curs_disp_shift												shifts only the cursor position to the left
	0	0	0	0	0	1	0	0	0	0	MICRO $\circ$ KO		
23	Write_data to CGRAM/DDRAM												writes 'C' correction; display moves to the left
	1	0	0	1	0	0	0	0	1	1	ICRO $\circ$ K $\circ$		
24	Curs_disp_shift												shifts the display and cursor to the right
	0	0	0	0	0	1	1	1	0	0	MICRO $\circ$ C $\circ$		
25	Curs_disp_shift												shifts only the cursor to the right
	0	0	0	0	0	1	0	1	0	0	MICRO $\circ$ C $\circ$ _		

Table 41. 8-bit operation, 1-line display example; using external reset (character set 'A') ...continued

Step	Instruction										Display	Operation
	RS	R/W	DB7	DB6	DB5	DB4	DB3	DB2	DB1	DB0		
26	Write_data to CGRAM/DDRAM											writes 'M'
	1	0	0	1	0	0	1	1	0	1	ICROCOM_	
27	Return_home											returns both display and cursor to the original position (address 0)
	0	0	0	0	0	0	0	0	1	0	PHILIPS M	

Table 42. 8-bit operation, 1-line display and icon example; using external reset (character set 'A')

Step	Instruction										Display	Operation
	RS	R/W	DB7	DB6	DB5	DB4	DB3	DB2	DB1	DB0		
1	power supply on											initialized by the external reset; no display appears
2	Function_set											sets to 8-bit operation, selects 1-line display and $V_{LCD} = V_0$
	0	0	0	0	1	1	0	0	0	0		
3	Display_ctl											turns on display and cursor; entire display is blank after initialization
	0	0	0	0	0	0	1	1	1	0	_	
4	Entry_mode_set											sets mode to increment the address by 1 and to shift the cursor to the right at the time of the write to the DD/CGRAM; display is not shifted
	0	0	0	0	0	0	0	1	1	0	_	
5	Set_CGRAM											sets the CGRAM address to position of character 0; the CGRAM is selected
	0	0	0	1	0	0	0	0	0	0	_	
6	Write_data to CGRAM/DDRAM											writes data to CGRAM for icon even phase; icons appears
	1	0	0	0	0	0	1	0	1	0	_	
7	:										_	
8	Set_CGRAM											sets the CGRAM address to position of character 4; the CGRAM is selected
	0	0	0	1	1	1	0	0	0	0	_	
9	Write_data to CGRAM/DDRAM											writes data to CGRAM for icon odd phase
	1	0	0	0	0	0	1	0	1	0	_	
10	:										_	
11	Function_set											sets bit H = 1
	0	0	0	0	1	1	0	0	0	1	_	
12	Icon_ctl											icons blink
	0	0	0	0	0	0	1	0	1	0	_	
13	Function_set											sets bit H = 0
	0	0	0	0	1	1	0	0	0	1	_	
14	Set_DDRAM											sets the DDRAM address to the first position; DDRAM is selected
	0	0	1	0	0	0	0	0	0	0		
15	Write_data to CGRAM/DDRAM											writes 'P'; the cursor is incremented by 1 and shifted to the right
	1	0	0	1	0	1	0	0	0	0	P_	
16	Write_data to CGRAM/DDRAM											writes 'H'
	1	0	0	1	0	0	1	0	0	0	PH_	

Table 42. 8-bit operation, 1-line display and icon example; using external reset (character set 'A') ...continued

Step	Instruction										Display	Operation
	RS	R/W	DB7	DB6	DB5	DB4	DB3	DB2	DB1	DB0		
17 to 21	:										PHILIPS_	writes 'ILIPS'
22	Return_home											returns both display and cursor to the original position (address 0)
	0	0	0	0	0	0	0	0	1	0	PHILIPS	

### 16.11 8-bit operation, 2-line display

For a 2-line display the cursor automatically moves from the first to the second line after the 40th digit of the first line has been written. Thus, if there are only 8 characters in the first line, the DDRAM address must be set after the 8th character is completed (see Table 43). It should be noted that both lines of the display are always shifted together; data does not shift from one line to the other.

Table 43. 8-bit operation, 2-line display example; using external reset (character set 'A')

Step	Instruction										Display	Operation
	RS	R/W	DB7	DB6	DB5	DB4	DB3	DB2	DB1	DB0		
1	power supply on											initialized by the external reset; no display appears
2	Function_set											sets to 8-bit operation; selects 2-line display and V <sub>LCD</sub> generator off
	0	0	0	0	1	1	0	1	0	0		
3	display mode on/off control											turns on display and cursor; entire display is blank after initialization
	0	0	0	0	0	0	1	1	1	0	_	
4	Entry_mode_set											sets mode to increment the address by 1 and to shift the cursor to the right at the time of write to the CG/DDRAM; display is not shifted
	0	0	0	0	0	0	0	1	1	0	_	
5	Write_data to CGRAM/DDRAM											writes 'P'; the DDRAM has already been selected by initialization at power-on; the cursor is incremented by 1 and shifted to the right
	1	0	0	1	0	1	0	0	0	0	P_	
6 to 10	:										PHILIP_	writes 'HILIP'
11	Write_data to CGRAM/DDRAM											writes 'S'
	1	0	0	1	0	1	0	0	1	1	PHILIPS_	
12	Set_DDRAM											sets DDRAM address to position the cursor at the head of the 2nd line
	0	0	1	1	0	0	0	0	0	0	PHILIPS_	
13	Write_data to CGRAM/ DDRAM											writes 'M'
	1	0	0	1	0	0	1	1	0	1	PHILIPS M_	
14 to 18	:										PHILIPS MICROC_	writes 'ICROC'
19	Write_data to CGRAM/DDRAM											writes 'O'
	1	0	0	1	0	0	1	1	1	1	PHILIPS MICROCO_	

Table 43. 8-bit operation, 2-line display example; using external reset (character set 'A') ...continued

Step	Instruction										Display	Operation
	RS	R/W	DB7	DB6	DB5	DB4	DB3	DB2	DB1	DB0		
20	Write_data to CGRAM/DDRAM											sets mode for display shift at the time of write
	0	0	0	0	0	0	0	1	1	1	PHILIPS MICROCO_	
21	Write_data to CGRAM/DDRAM											writes 'M'; display is shifted to the left; the first and second lines shift together
	1	0	0	1	0	0	1	1	0	1	HILIPS ICROCOM_	
22	:										:	
23	Return_home											returns both display and cursor to the original position (address 0)
	0	0	0	0	0	0	0	0	1	0	PHILIPS MICROCOM	

### 16.12 I<sup>2</sup>C-bus operation, 1-line display

A control byte is required with most commands (see [Table 44](#)).

Table 44. Example of I<sup>2</sup>C-bus operation; 1-line display (using external reset, assuming pin SA0 = V<sub>SS</sub>)<sup>[1]</sup>

Step	I <sup>2</sup> C-bus byte									Display	Operation
1	I <sup>2</sup> C-bus start										initialized; no display appears
2	slave address for write										during the acknowledge cycle SDA will be pulled-down by the PCF2119x
	SA6	SA5	SA4	SA3	SA2	SA1	SA0	R/W	Ack		
	0	1	1	1	0	1	0	0	1		
3	send a control byte for Function_set										control byte sets RS for following data bytes
	CO	RS	0	0	0	0	0	0	Ack		
	0	0	0	0	0	0	0	0	1		
4	Function_set										selects 1-line display and V <sub>LCD</sub> = V <sub>0</sub> ; SCL pulse during acknowledge cycle starts execution of instruction
	DB7	DB6	DB5	DB4	DB3	DB2	DB1	DB0	Ack		
	0	0	1	X	0	0	0	0	1		
5	Display_ctl										turns on display and cursor; entire display shows character code 20h (blank in ASCII-like character sets)
	DB7	DB6	DB5	DB4	DB3	DB2	DB1	DB0	Ack	—	
	0	0	0	0	1	1	1	0	1		
6	Entry_mode_set										sets mode to increment the address by 1 and to shift the cursor to the right at the time of write to the DDRAM or CGRAM; display is not shifted
	DB7	DB6	DB5	DB4	DB3	DB2	DB1	DB0	Ack	—	
	0	0	0	0	0	1	1	0	1		
7	I <sup>2</sup> C-bus start									—	for writing data to DDRAM, RS must be set to 1; therefore a control byte is needed
8	slave address for write										
	SA6	SA5	SA4	SA3	SA2	SA1	SA0	R/W	Ack	—	
	0	1	1	1	0	1	0	0	1		
9	send a control byte for Write_data										
	CO	RS	0	0	0	0	0	0	Ack	—	
	0	1	0	0	0	0	0	0	1		



Table 44. Example of I<sup>2</sup>C-bus operation; 1-line display (using external reset, assuming pin SA0 = V<sub>SS</sub>)<sup>[1]</sup> ...continued

Step	I <sup>2</sup> C-bus byte										Display	Operation
10	Write_data to DDRAM										P_	writes 'P'; the DDRAM has been selected at power-on; the cursor is incremented by 1 and shifted to the right
	DB7	DB6	DB5	DB4	DB3	DB2	DB1	DB0	Ack			
	0	1	0	1	0	0	0	0	1			
11	Write_data to DDRAM										PH_	writes 'H'
	DB7	DB6	DB5	DB4	DB3	DB2	DB1	DB0	Ack			
	0	1	0	0	1	0	0	0	1			
12 to 15	:										PHILIP_	writes 'ILIP'
16	Write_data to DDRAM										PHILIPS_	writes 'S'
	DB7	DB6	DB5	DB4	DB3	DB2	DB1	DB0	Ack			
	0	1	0	1	0	0	1	1	1			
17	optional I <sup>2</sup> C-bus STOP										PHILIPS_	
18	I <sup>2</sup> C-bus start										PHILIPS_	
19	slave address for write										PHILIPS_	
	SA6	SA5	SA4	SA3	SA2	SA1	SA0	R/W	Ack			
	0	1	1	1	0	1	0	0	1			
20	control byte										PHILIPS_	
	CO	RS	0	0	0	0	0	0	Ack			
	1	0	0	0	0	0	0	0	1			
21	Return_home										PHILIPS	sets DDRAM address 0 in address counter (also returns shifted display to original position; DDRAM contents unchanged); this instruction does not update the data register
	DB7	DB6	DB5	DB4	DB3	DB2	DB1	DB0	Ack			
	0	0	0	0	0	0	1	0	1			
22	I <sup>2</sup> C-bus start										PHILIPS	
23	slave address for read										PHILIPS	during the acknowledge cycle the content of the data register is loaded into the internal I <sup>2</sup> C-bus interface to be shifted out; in the previous instruction neither a 'set address' nor a Read_data has been performed; therefore the content of the data register was unknown; bit R/W has to be set to logic 1 while still in I <sup>2</sup> C-write mode
	SA6	SA5	SA4	SA3	SA2	SA1	SA0	R/W	Ack			
	0	1	1	1	0	1	0	1	1			
24	control byte for read										PHILIPS	DDRAM content will be read from following instructions
	CO	RS	0	0	0	0	0	0	Ack			
	0	1	1	0	0	0	0	0	1			
25	Read_data: 8 × SCL + master acknowledge <sup>[2]</sup>										PHILIPS	8 × SCL; content loaded into interface during previous acknowledge cycle is shifted out over SDA; MSB is DB7; during master acknowledge content of DDRAM address 01 is loaded into the I <sup>2</sup> C-bus interface
	DB7	DB6	DB5	DB4	DB3	DB2	DB1	DB0	Ack			
	X	X	X	X	X	X	X	X	0			
26	Read_data: 8 × SCL + master acknowledge <sup>[2]</sup>										PHILIPS	8 × SCL; code of letter 'H' is read first; during master acknowledge code of 'I' is loaded into the I <sup>2</sup> C-bus interface
	DB7	DB6	DB5	DB4	DB3	DB2	DB1	DB0	Ack			
	0	1	0	0	1	0	0	0	0			

**Table 44. Example of I<sup>2</sup>C-bus operation; 1-line display (using external reset, assuming pin SA0 = V<sub>SS</sub>)<sup>[1]</sup> ...continued**

Step	I <sup>2</sup> C-bus byte										Display	Operation
27	Read_data: 8 × SCL + no master acknowledge <sup>[2]</sup>										PHILIPS	no master acknowledge; after the content of the I <sup>2</sup> C-bus interface register is shifted out no internal action is performed; no new data is loaded to the interface register, data register is not updated, address counter is not incremented and cursor is not shifted
	DB7	DB6	DB5	DB4	DB3	DB2	DB1	DB0	Ack			
	0	1	0	0	1	0	0	1	1			
28	I <sup>2</sup> C-bus STOP										PHILIPS	

[1] X = don't care.

[2] SDA is left at high-impedance by the microcontroller during the read acknowledge.

### 16.13 Initialization

**Table 45. Initialization by instruction, 8-bit interface (1)**

Step	Instruction										Description
	RS	R/W	DB7	DB6	DB5	DB4	DB3	DB2	DB1	DB0	
1	power-on or unknown state										
2	wait 2 ms										after internal reset has been applied
3	Function_set										interface is 8 bits long; BF cannot be checked before this instruction
	0	0	0	0	1	1	X	X	X	X	
4	wait 2 ms										
5	Function_set										interface is 8 bits long; BF cannot be checked before this instruction
	0	0	0	0	1	1	X	X	X	X	
6	wait more than 40 μs										
7	Function_set										interface is 8 bits long; BF cannot be checked before this instruction
	0	0	0	0	1	1	X	X	X	X	
BF can be checked after the following instructions; when BF is not checked, the waiting time between instructions is the specified instruction time (see Table 12)											
8	Function_set (interface is 8 bits long)										specify number of display lines
	0	0	0	0	1	1	0	M	0	H	
9	Display_ctl										display off
	0	0	0	0	0	0	1	0	0	0	
10	Clear_display										
	0	0	0	0	0	0	0	0	0	1	
11	Entry_mode_set										
	0	0	0	0	0	0	0	1	I_D	S	
12	initialization ends										

[1] X = don't care.

**Table 46. Initialization by instruction, 4-bit interface; not applicable for I<sup>2</sup>C-bus operation**

Step	Instruction						Description
	RS	R/W	DB7	DB6	DB5	DB4	
1	power-on or unknown state						
2	wait 2 ms after internal reset has been applied						
3	Function_set						interface is 8 bits long; BF cannot be checked before this instruction
	0	0	0	0	1	1	
4	wait 2 ms						
5	Function_set						interface is 8 bits long; BF cannot be checked before this instruction
	0	0	0	0	1	1	
6	wait more than 40 μs						
7	Function_set						interface is 8 bits long; BF cannot be checked before this instruction
	0	0	0	0	1	1	
BF can be checked after the following instructions; when BF is not checked, the waiting time between instructions is the specified instruction time (see <a href="#">Table 12</a> )							
8	Function_set						set interface to 4 bit long interface is 8 bit long
	0	0	0	0	1	0	
9	Function_set						set interface to 4 bits long specify number of display line
	0	0	0	0	1	0	
	0	0	0	M	0	H	
10	Display_ctl						display off
	0	0	0	0	0	0	
	0	0	1	0	0	0	
11	Clear_display						
	0	0	0	0	0	0	
	0	0	0	0	0	1	
12	Entry_mode_set						
	0	0	0	0	0	0	
	0	0	0	1	I_D	S	
:							
13	Initialization ends						

### 16.14 User defined characters and symbols

Up to 16 user defined characters may be stored in the CGRAM. The content of the CGRAM is lost during power-down, therefore the CGRAM has to be rewritten after every power-on.

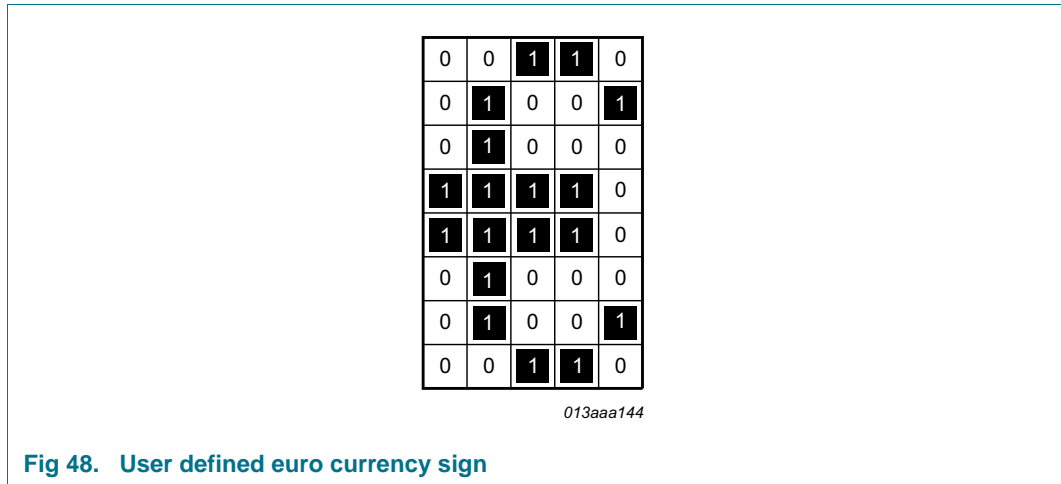

Below some source code is printed, which shows how a user defined character is defined - in this case the euro currency sign. The display used is a 2 lines by 16 characters display and the interface is the I<sup>2</sup>C-bus:

```
// Write a user defined character into the CGRAM
startI2C();
// PCF2119 slave address for write, SA0 is connected to Vdd
SendI2CAddress(0x76);
// MSB (Continuation bit Co) = 0, more than one byte may follow. Bit6, RS=0, next byte
// is command byte
i2c_write(0x00);
// 2 lines x 16, 1/18 duty, basic instruction set. Next byte will be another command.
i2c_write(0x24);
// Set CGRAM address to 0
i2c_write(0x40);
// Repeated Start condition
startI2C();
SendI2CAddress(0x76);
// RS=1, next byte is a data byte
i2c_write(0x40);

// Here the data bytes to define the character
// Behind the write commands the 5x8 dot matrix is shown, the 1 represents a on pixel.
// The Euro currency character can be recognized by the 0/1 pattern (see Figure 48)
i2c_write(0x06); // 00110
i2c_write(0x09); // 01001
i2c_write(0x08); // 01000
i2c_write(0x1E); // 11110
i2c_write(0x1E); // 11110
i2c_write(0x08); // 01000
i2c_write(0x09); // 01001
i2c_write(0x06); // 00110
i2c_stop();
// Until here the definition of the character and writing it into the CGRAM. Now it
// still needs to be displayed. See below.
```

```
// PCF2119, setting of proper display modes
startI2C();
// PCF2119 slave address for write, SA0 is connected to Vdd
SendI2CAddress(0x76);
// MSB (Continuation bit Co) = 0, more than one byte may follow. Bit6, RS=0, next byte
// is command byte
i2c_write(0x00);
// 2 lines x 16, 1/18 duty, extended instruction set. Next byte will be another
// command.
i2c_write(0x25);
// Set display configuration to right to left, column 80 to 1. Row data displ. top to
// bottom, 1 to 16.
i2c_write(0x06);
// Set to character mode, full display, icon blink disabled
i2c_write(0x08);
// Set voltage multiplier to 2
i2c_write(0x40);
// Set Vlcd and store in register VA
i2c_write(0xA0);
// Change from extended instruction set to basic instruction set
i2c_write(0x24);
// Display control: set display on, cursor off, no blink
i2c_write(0x0C);
// Entry mode set, increase DDRAM after access, no shift
i2c_write(0x06);
// Return home, set DDRAM address 0 in address counter
i2c_write(0x02);
// Clear entire display, set DDRAM address to 0 in address counter
i2c_write(0x01);

// Repeated Start condition because RS needs to be changed from 0 to 1
startI2C();
SendI2CAddress(0x76);
// RS=1, next byte is data
i2c_write(0x40);
// Write the character at address 0, which is the previously defined Euro currency
// character
i2c_write(0x00);
i2c_stop();
```

17. Bare die outline

Bare die: 168 bumps

PCF2119X



Fig 49. Bare die outline of PCF2119x

**Table 47. Dimensions of PCF2119x**

Original dimensions are in mm.

Unit (mm)	A	A <sub>1</sub>	b	b <sub>1</sub>	D	E	e	e <sub>1</sub>	L
max		0.0225							
nom	0.38 <sup>[1]</sup>	0.0175	0.05	0.1	7.6	1.7	0.07	0.35	0.09
min		0.0125							

[1] PCF2119RU/2DB/2 has a PI scratch protection coating, adding 3.6 μm to to the die thickness.

**Table 48. Pin location**

All X and Y coordinates are referenced to the center of the chip (dimensions in μm).

Symbol	Pin	X	Y	Description
V <sub>DD1</sub>	1	+745	-274	logic supply voltage 1
V <sub>DD1</sub>	2	+745	-204	
V <sub>DD1</sub>	3	+745	-134	
V <sub>DD1</sub>	4	+745	-64	
V <sub>DD1</sub>	5	+745	+6	
V <sub>DD1</sub>	6	+745	+76	
V <sub>DD2</sub>	7	+745	+146	V <sub>LCD</sub> generator supply voltage 2
V <sub>DD2</sub>	8	+745	+216	
V <sub>DD2</sub>	9	+745	+286	
V <sub>DD2</sub>	10	+745	+356	
V <sub>DD2</sub>	11	+745	+426	
V <sub>DD2</sub>	12	+745	+496	
V <sub>DD2</sub>	13	+745	+566	
V <sub>DD2</sub>	14	+745	+636	
V <sub>DD3</sub>	15	+745	+706	
V <sub>DD3</sub>	16	+745	+776	
V <sub>DD3</sub>	17	+745	+846	
V <sub>DD3</sub>	18	+745	+916	
E	19	+745	+986	data bus clock input
T1	20	+745	+1196	test pin 1
T2	21	+745	+1406	test pin 2
V <sub>SS1</sub>	22	+745	+1616	ground 1
V <sub>SS1</sub>	23	+745	+1686	
V <sub>SS1</sub>	24	+745	+1756	
V <sub>SS1</sub>	25	+745	+1826	
V <sub>SS1</sub>	26	+745	+1896	
V <sub>SS1</sub>	27	+745	+1966	
V <sub>SS1</sub>	28	+745	+2036	
V <sub>SS1</sub>	29	+745	+2106	

**Table 48. Pin location ...continued**

All X and Y coordinates are referenced to the center of the chip (dimensions in  $\mu\text{m}$ ).

Symbol	Pin	X	Y	Description
V <sub>SS2</sub>	30	+745	+2176	ground 2
V <sub>SS2</sub>	31	+745	+2246	
V <sub>SS2</sub>	32	+745	+2316	
V <sub>SS2</sub>	33	+745	+2386	
V <sub>SS2</sub>	34	+745	+2456	
V <sub>SS2</sub>	35	+745	+2666	
V <sub>LCDSENSE</sub>	36	+745	+2736	input for voltage multiplier regulation
V <sub>LCDOUT</sub>	37	+745	+2806	V <sub>LCD</sub> output
V <sub>LCDOUT</sub>	38	+745	+2876	
V <sub>LCDOUT</sub>	39	+745	+2946	
V <sub>LCDOUT</sub>	40	+745	+3016	
V <sub>LCDOUT</sub>	41	+745	+3086	V <sub>LCD</sub> output
V <sub>LCDOUT</sub>	42	+745	+3156	
V <sub>LCDOUT</sub>	43	+745	+3226	
V <sub>LCDIN</sub>	44	+745	+3296	input for generation of LCD bias levels
V <sub>LCDIN</sub>	45	+745	+3366	
V <sub>LCDIN</sub>	46	+745	+3436	
V <sub>LCDIN</sub>	47	+745	+3506	
V <sub>LCDIN</sub>	48	+745	+3576	
V <sub>LCDIN</sub>	49	+745	+3646	
dummy	50	-745	+3576	dummy
R8	51	-745	+3506	LCD row driver output
R7	52	-745	+3436	
R6	53	-745	+3366	
R5	54	-745	+3296	
R4	55	-745	+3226	
R3	56	-745	+3156	
R2	57	-745	+3086	
R1	58	-745	+3016	
R17	59	-745	+2946	
C80	60	-745	+2876	LCD column driver output
C79	61	-745	+2806	
C78	62	-745	+2736	
C77	63	-745	+2666	
C76	64	-745	+2596	
C75	65	-745	+2526	
C74	66	-745	+2456	
C73	67	-745	+2386	
C72	68	-745	+2316	
C71	69	-745	+2246	



**Table 48. Pin location ...continued**All X and Y coordinates are referenced to the center of the chip (dimensions in  $\mu\text{m}$ ).

Symbol	Pin	X	Y	Description
C70	70	-745	+2176	LCD column driver output
C69	71	-745	+2106	
C68	72	-745	+2036	
C67	73	-745	+1966	
C66	74	-745	+1896	
C65	75	-745	+1756	
C64	76	-745	+1686	
C63	77	-745	+1616	
C62	78	-745	+1546	
C61	79	-745	+1476	
C60	80	-745	+1406	
C59	81	-745	+1336	
C58	82	-745	+1266	
C57	83	-745	+1196	
C56	84	-745	+1126	
C55	85	-745	+1056	
C54	86	-745	+986	
C53	87	-745	+916	
C52	88	-745	+846	
C51	89	-745	+776	
C50	90	-745	+706	
C49	91	-745	+636	
C48	92	-745	+566	
C47	93	-745	+496	
C46	94	-745	+426	
C45	95	-745	+356	
C44	96	-745	+286	
C43	97	-745	+216	
C42	98	-745	+146	
C41	99	-745	+76	
R17DUP	100	-745	+6	LCD row driver output
C40	101	-745	-64	LCD column driver output
C39	102	-745	-134	
C38	103	-745	-204	
C37	104	-745	-274	
C36	105	-745	-344	
C35	106	-745	-414	
C34	107	-745	-484	
C33	108	-745	-554	
C32	109	-745	-624	

**Table 48. Pin location ...continued**

All X and Y coordinates are referenced to the center of the chip (dimensions in  $\mu\text{m}$ ).

Symbol	Pin	X	Y	Description
C31	110	-745	-694	LCD column driver output
C30	111	-745	-764	
C29	112	-745	-834	
C28	113	-745	-904	
C27	114	-745	-974	
C26	115	-745	-1044	
C25	116	-745	-1114	
C24	117	-745	-1184	
C23	118	-745	-1254	
C22	119	-745	-1324	
C21	120	-745	-1394	
C20	121	-745	-1464	
C19	122	-745	-1534	
C18	123	-745	-1604	
C17	124	-745	-1674	
C16	125	-745	-1744	
C15	126	-745	-1884	
C14	127	-745	-1954	
C13	128	-745	-2024	
C12	129	-745	-2094	
C11	130	-745	-2164	
C10	131	-745	-2234	
C9	132	-745	-2304	
C8	133	-745	-2374	
C7	134	-745	-2444	
C6	135	-745	-2514	
C5	136	-745	-2584	
C4	137	-745	-2654	
C3	138	-745	-2724	
C2	139	-745	-2794	
C1	140	-745	-2864	
R18	141	-745	-2934	LCD row driver output
R9	142	-745	-3004	
R10	143	-745	-3074	
R11	144	-745	-3144	
R12	145	-745	-3214	
R13	146	-745	-3284	
R14	147	-745	-3354	
R15	148	-745	-3424	
R16	149	-745	-3494	

**Table 48. Pin location ...continued**

All X and Y coordinates are referenced to the center of the chip (dimensions in  $\mu\text{m}$ ).

Symbol	Pin	X	Y	Description
dummy	150	-745	-3704	dummy
SCL	151	+745	-3704	I <sup>2</sup> C-bus serial clock input
SCL	152	+745	-3634	
T3	153	+745	-3494	test pin 3
POR	154	+745	-3424	external Power-On Reset (POR) input
PD	155	+745	-3214	power-down mode select input
SDA	156	+745	-3004	I <sup>2</sup> C-bus serial data input/output
SDA	157	+745	-2934	
R/W	158	+745	-2584	read/write input
RS	159	+745	-2374	register select input
DB0	160	+745	-2164	8-bit bidirectional data bus; bit 0
DB1	161	+745	-1954	8-bit bidirectional data bus; bit 1
DB2	162	+745	-1744	8-bit bidirectional data bus; bit 2
DB3/SA0	163	+745	-1534	8-bit bidirectional data bus; bit 3
DB4	164	+745	-1324	8-bit bidirectional data bus; bit 4
DB5	165	+745	-1114	8-bit bidirectional data bus; bit 5
DB6	166	+745	-904	8-bit bidirectional data bus; bit 6
DB7	167	+745	-694	8-bit bidirectional data bus; bit 7
OSC	168	+745	-484	oscillator or external clock input

**Table 49. Alignment mark location**

All X and Y coordinates are referenced to the center of the chip (dimensions in  $\mu\text{m}$ ).

Symbol	Pin	X	Y
AM1	-	+745	-2689
AM2	-	+745	+2561
AM3	-	-745	+3681
AM4	-	-745	-3599

## 18. Handling information

All input and output pins are protected against ElectroStatic Discharge (ESD) under normal handling. When handling Metal-Oxide Semiconductor (MOS) devices ensure that all normal precautions are taken as described in *JESD625-A*, *IEC 61340-5* or equivalent standards.

19. Packing information

19.1 Packing information on the tray



**Table 50. Specification of 3 inch tray details**

Tray details are shown in [Figure 50](#). Nominal values without production tolerances.

Tray details														
Dimensions														
A	B	C	D	E	F	G	H	J	K	L	M	N	O	Unit
9.5	3.0	7.69	1.81	76.0	68.0	57.0	6.5	9.5	63	4.2	2.6	3.2	0.50	mm
Number of pockets														
x direction								y direction						
7								22						



## 20. Appendix

### 20.1 LCD character driver selection

Table 51. Selection of LCD character drivers

Type name	Number of				Character set	V <sub>DD1</sub> (V)	V <sub>DD2</sub> (V)	V <sub>LCD</sub> (V)	f <sub>fr</sub> (Hz)	V <sub>LCD</sub> (V) charge pump	V <sub>LCD</sub> (V) temp. comp	T <sub>amb</sub> (°C)	Interface	AEC-Q100
	Lines × Characters	Icons												
PCF2113AU	1 × 24	2 × 12	-	120	A	1.8 to 5.5	2.2 to 4	2.2 to 6.5	95	Y	Y	-40 to 85	I <sup>2</sup> C / Parallel	N
PCF2113DU	1 × 24	2 × 12	-	120	D	1.8 to 5.5	2.2 to 4	2.2 to 6.5	95	Y	Y	-40 to 85	I <sup>2</sup> C / Parallel	N
PCF2113EU	1 × 24	2 × 12	-	120	E	1.8 to 5.5	2.2 to 4	2.2 to 6.5	95	Y	Y	-40 to 85	I <sup>2</sup> C / Parallel	N
PCF2113WU	1 × 24	2 × 12	-	120	W	1.8 to 5.5	2.2 to 4	2.2 to 6.5	95	Y	Y	-40 to 85	I <sup>2</sup> C / Parallel	N
PCF2116AU	1 × 24	2 × 24	4 × 12	-	A	2.5 to 6	2.5 to 6	3.5 to 9	65	Y	N	-40 to 85	I <sup>2</sup> C / Parallel	N
PCF2116CU	1 × 24	2 × 24	4 × 12	-	C	2.5 to 6	2.5 to 6	3.5 to 9	65	Y	N	-40 to 85	I <sup>2</sup> C / Parallel	N
PCF2119AU	1 × 32	2 × 16	-	160	A	1.5 to 5.5	2.2 to 4	2.2 to 6.5	95	Y	Y	-40 to 85	I <sup>2</sup> C / Parallel	N
PCF2119DU	1 × 32	2 × 16	-	160	D	1.5 to 5.5	2.2 to 4	2.2 to 6.5	95	Y	Y	-40 to 85	I <sup>2</sup> C / Parallel	N
PCF2119FU	1 × 32	2 × 16	-	160	F	1.5 to 5.5	2.2 to 4	2.2 to 6.5	95	Y	Y	-40 to 85	I <sup>2</sup> C / Parallel	N
PCF2119IU	1 × 32	2 × 16	-	160	I	1.5 to 5.5	2.2 to 4	2.2 to 6.5	95	Y	Y	-40 to 85	I <sup>2</sup> C / Parallel	N
PCF2119RU	1 × 32	2 × 16	-	160	R	1.5 to 5.5	2.2 to 4	2.2 to 6.5	95	Y	Y	-40 to 85	I <sup>2</sup> C / Parallel	N
PCF2119SU	1 × 32	2 × 16	-	160	S	1.5 to 5.5	2.2 to 4	2.2 to 6.5	95	Y	Y	-40 to 85	I <sup>2</sup> C / Parallel	N
PCF21219DUGR	1 × 32	2 × 16	-	160	R	1.5 to 5.5	2.2 to 4	2.2 to 6.5	220	Y	Y	-40 to 85	I <sup>2</sup> C / Parallel	N
PCA2117DUGR	1 × 40	2 × 20	-	200	R	2.5 to 5.5	2.5 to 5.5	4 to 16	45 to 360 <sup>[1]</sup>	Y	Y	-40 to 105	I <sup>2</sup> C / SPI	Y
PCA2117DUGS	1 × 40	2 × 20	-	200	S	2.5 to 5.5	2.5 to 5.5	4 to 16	45 to 360 <sup>[1]</sup>	Y	Y	-40 to 105	I <sup>2</sup> C / SPI	Y

[1] Software programmable.

## 21. Abbreviations

Table 52. Abbreviations

Acronym	Description
CGRAM	Character Generator RAM
CGROM	Character Generator ROM
CMOS	Complementary Metal-Oxide Semiconductor
COG	Chip-On-Glass
DC	Direct Current
DDRAM	Display Data RAM
HBM	Human Body Model
I <sup>2</sup> C	Inter-Integrated Circuit
IC	Integrated Circuit
ITO	Indium Tin Oxide
LCD	Liquid Crystal Display
LSB	Least Significant Bit
MM	Machine Model
MSB	Most Significant Bit
MUX	Multiplexer
PCB	Printed-Circuit Board
PI	Polyimide
POR	Power-On Reset
RAM	Random Access Memory
RMS	Root Mean Square
ROM	Read Only Memory
SCL	Serial CLock line
SDA	Serial DAta line



## 22. References

---

- [1] **AN10170** — Design guidelines for COG modules with NXP monochrome LCD drivers
- [2] **AN10706** — Handling bare die
- [3] **AN10853** — ESD and EMC sensitivity of IC
- [4] **AN11267** — EMC and system level ESD design guidelines for LCD drivers
- [5] **IEC 60134** — Rating systems for electronic tubes and valves and analogous semiconductor devices
- [6] **IEC 61340-5** — Protection of electronic devices from electrostatic phenomena
- [7] **JESD22-A114** — Electrostatic Discharge (ESD) Sensitivity Testing Human Body Model (HBM)
- [8] **JESD22-A115** — Electrostatic Discharge (ESD) Sensitivity Testing Machine Model (MM)
- [9] **JESD78** — IC Latch-Up Test
- [10] **JESD625-A** — Requirements for Handling Electrostatic-Discharge-Sensitive (ESDS) Devices
- [11] **UM10204** — I<sup>2</sup>C-bus specification and user manual
- [12] **UM10569** — Store and transport requirements

## 23. Revision history

Table 53. Revision history

Document ID	Release date	Data sheet status	Change notice	Supersedes
PCF2119X v.12	20150416	Product data sheet	-	PCF2119X v.11
Modifications:	<ul style="list-style-type: none"> <li>• The format of this data sheet has been redesigned to comply with the new identity guidelines of NXP Semiconductors.</li> <li>• Legal texts have been adapted to the new company name where appropriate.</li> <li>• Adjusted description in <a href="#">Section 16.1</a></li> <li>• Corrected description of the dummy pins in <a href="#">Table 4</a> and <a href="#">Table 48</a></li> </ul>			
PCF2119X v.11	20130715	Product data sheet	-	PCF2119X v.10
PCF2119X v.10	20111031	Product data sheet	-	PCF2119X v.9
PCF2119X v.9	20110414	Product data sheet	-	PCF2119X v.8
PCF2119X v.8	20110404	Product data sheet	-	PCF2119X v.7
PCF2119X v.7	20101115	Product data sheet	-	PCF2119X v.6
PCF2119X v.6	20100908	Product data sheet	-	PCF2119X_5
PCF2119X_5	20090813	Product data sheet	-	PCF2119X_4
PCF2119X_4	20030130	Product specification	-	PCF2119X_3
PCF2119X_3	20020116	Product specification	-	PCF2119X_2
PCF2119X_2	19990302	Product specification	-	PCF2119X_1
PCF2119X_1	19971121	Objective specification	-	-

## 24. Legal information

### 24.1 Data sheet status

Document status <sup>[1][2]</sup>	Product status <sup>[3]</sup>	Definition
Objective [short] data sheet	Development	This document contains data from the objective specification for product development.
Preliminary [short] data sheet	Qualification	This document contains data from the preliminary specification.
Product [short] data sheet	Production	This document contains the product specification.

[1] Please consult the most recently issued document before initiating or completing a design.

[2] The term 'short data sheet' is explained in section "Definitions".

[3] The product status of device(s) described in this document may have changed since this document was published and may differ in case of multiple devices. The latest product status information is available on the Internet at URL <http://www.nxp.com>.

### 24.2 Definitions

**Draft** — The document is a draft version only. The content is still under internal review and subject to formal approval, which may result in modifications or additions. NXP Semiconductors does not give any representations or warranties as to the accuracy or completeness of information included herein and shall have no liability for the consequences of use of such information.

**Short data sheet** — A short data sheet is an extract from a full data sheet with the same product type number(s) and title. A short data sheet is intended for quick reference only and should not be relied upon to contain detailed and full information. For detailed and full information see the relevant full data sheet, which is available on request via the local NXP Semiconductors sales office. In case of any inconsistency or conflict with the short data sheet, the full data sheet shall prevail.

**Product specification** — The information and data provided in a Product data sheet shall define the specification of the product as agreed between NXP Semiconductors and its customer, unless NXP Semiconductors and customer have explicitly agreed otherwise in writing. In no event however, shall an agreement be valid in which the NXP Semiconductors product is deemed to offer functions and qualities beyond those described in the Product data sheet.

### 24.3 Disclaimers

**Limited warranty and liability** — Information in this document is believed to be accurate and reliable. However, NXP Semiconductors does not give any representations or warranties, expressed or implied, as to the accuracy or completeness of such information and shall have no liability for the consequences of use of such information. NXP Semiconductors takes no responsibility for the content in this document if provided by an information source outside of NXP Semiconductors.

In no event shall NXP Semiconductors be liable for any indirect, incidental, punitive, special or consequential damages (including - without limitation - lost profits, lost savings, business interruption, costs related to the removal or replacement of any products or rework charges) whether or not such damages are based on tort (including negligence), warranty, breach of contract or any other legal theory.

Notwithstanding any damages that customer might incur for any reason whatsoever, NXP Semiconductors' aggregate and cumulative liability towards customer for the products described herein shall be limited in accordance with the *Terms and conditions of commercial sale* of NXP Semiconductors.

**Right to make changes** — NXP Semiconductors reserves the right to make changes to information published in this document, including without limitation specifications and product descriptions, at any time and without notice. This document supersedes and replaces all information supplied prior to the publication hereof.

**Suitability for use** — NXP Semiconductors products are not designed, authorized or warranted to be suitable for use in life support, life-critical or safety-critical systems or equipment, nor in applications where failure or malfunction of an NXP Semiconductors product can reasonably be expected to result in personal injury, death or severe property or environmental damage. NXP Semiconductors and its suppliers accept no liability for inclusion and/or use of NXP Semiconductors products in such equipment or applications and therefore such inclusion and/or use is at the customer's own risk.

**Applications** — Applications that are described herein for any of these products are for illustrative purposes only. NXP Semiconductors makes no representation or warranty that such applications will be suitable for the specified use without further testing or modification.

Customers are responsible for the design and operation of their applications and products using NXP Semiconductors products, and NXP Semiconductors accepts no liability for any assistance with applications or customer product design. It is customer's sole responsibility to determine whether the NXP Semiconductors product is suitable and fit for the customer's applications and products planned, as well as for the planned application and use of customer's third party customer(s). Customers should provide appropriate design and operating safeguards to minimize the risks associated with their applications and products.

NXP Semiconductors does not accept any liability related to any default, damage, costs or problem which is based on any weakness or default in the customer's applications or products, or the application or use by customer's third party customer(s). Customer is responsible for doing all necessary testing for the customer's applications and products using NXP Semiconductors products in order to avoid a default of the applications and the products or of the application or use by customer's third party customer(s). NXP does not accept any liability in this respect.

**Limiting values** — Stress above one or more limiting values (as defined in the Absolute Maximum Ratings System of IEC 60134) will cause permanent damage to the device. Limiting values are stress ratings only and (proper) operation of the device at these or any other conditions above those given in the Recommended operating conditions section (if present) or the Characteristics sections of this document is not warranted. Constant or repeated exposure to limiting values will permanently and irreversibly affect the quality and reliability of the device.

**Terms and conditions of commercial sale** — NXP Semiconductors products are sold subject to the general terms and conditions of commercial sale, as published at <http://www.nxp.com/profile/terms>, unless otherwise agreed in a valid written individual agreement. In case an individual agreement is concluded only the terms and conditions of the respective agreement shall apply. NXP Semiconductors hereby expressly objects to applying the customer's general terms and conditions with regard to the purchase of NXP Semiconductors products by customer.

**No offer to sell or license** — Nothing in this document may be interpreted or construed as an offer to sell products that is open for acceptance or the grant, conveyance or implication of any license under any copyrights, patents or other industrial or intellectual property rights.

**Export control** — This document as well as the item(s) described herein may be subject to export control regulations. Export might require a prior authorization from competent authorities.

**Non-automotive qualified products** — Unless this data sheet expressly states that this specific NXP Semiconductors product is automotive qualified, the product is not suitable for automotive use. It is neither qualified nor tested in accordance with automotive testing or application requirements. NXP Semiconductors accepts no liability for inclusion and/or use of non-automotive qualified products in automotive equipment or applications.

In the event that customer uses the product for design-in and use in automotive applications to automotive specifications and standards, customer (a) shall use the product without NXP Semiconductors' warranty of the product for such automotive applications, use and specifications, and (b) whenever customer uses the product for automotive applications beyond NXP Semiconductors' specifications such use shall be solely at customer's own risk, and (c) customer fully indemnifies NXP Semiconductors for any liability, damages or failed product claims resulting from customer design and use of the product for automotive applications beyond NXP Semiconductors' standard warranty and NXP Semiconductors' product specifications.

**Translations** — A non-English (translated) version of a document is for reference only. The English version shall prevail in case of any discrepancy between the translated and English versions.

**Bare die** — All die are tested on compliance with their related technical specifications as stated in this data sheet up to the point of wafer sawing and are handled in accordance with the NXP Semiconductors storage and transportation conditions. If there are data sheet limits not guaranteed, these will be separately indicated in the data sheet. There are no post-packing tests performed on individual die or wafers.

NXP Semiconductors has no control of third party procedures in the sawing, handling, packing or assembly of the die. Accordingly, NXP Semiconductors assumes no liability for device functionality or performance of the die or systems after third party sawing, handling, packing or assembly of the die. It is the responsibility of the customer to test and qualify their application in which the die is used.

All die sales are conditioned upon and subject to the customer entering into a written die sale agreement with NXP Semiconductors through its legal department.

## 24.4 Trademarks

Notice: All referenced brands, product names, service names and trademarks are the property of their respective owners.

**I<sup>2</sup>C-bus** — logo is a trademark of NXP Semiconductors N.V.

## 25. Contact information

For more information, please visit: <http://www.nxp.com>

For sales office addresses, please send an email to: [salesaddresses@nxp.com](mailto:salesaddresses@nxp.com)

## 26. Tables

Table 1. Ordering information	3	Table 47. Dimensions of PCF2119x	71
Table 2. Ordering options	3	Table 48. Pin location	71
Table 3. Marking codes	3	Table 49. Alignment mark location	75
Table 4. Pin description	6	Table 50. Specification of 3 inch tray details	77
Table 5. State after reset	9	Table 51. Selection of LCD character drivers	78
Table 6. Values of $V_A$ and $V_B$ and the corresponding $V_{LCD}$ values	10	Table 52. Abbreviations	80
Table 7. Bias levels as a function of multiplex rate	11	Table 53. Revision history	82
Table 8. Address space and wrap-around operation	18		
Table 9. Instruction set for I <sup>2</sup> C-bus commands	27		
Table 10. Control byte bit description	27		
Table 11. Register access selection	28		
Table 12. Instruction register overview	29		
Table 13. Function_set bit description	29		
Table 14. BF_AC bit	30		
Table 15. Read_data bit description	31		
Table 16. Write_data bit description	31		
Table 17. Clear_display bit description	32		
Table 18. Return_home bit description	32		
Table 19. Entry_mode_set bit description	33		
Table 20. Display_ctl bit description	33		
Table 21. Curs_disp_shift bit description	34		
Table 22. Set_CGRAM bit description	35		
Table 23. Set_DDRAM bit description	35		
Table 24. Screen_conf bit description	36		
Table 25. Disp_conf bit description	36		
Table 26. Icon_ctl bit description	37		
Table 27. Normal/icon mode operation	38		
Table 28. Blink effect for icons and cursor character blink	38		
Table 29. Temp_ctl bit description	40		
Table 30. TC[1:0] selection of $V_{LCD}$ temperature coefficient	40		
Table 31. HV_gen bit description	40		
Table 32. Voltage multiplier control bits	40		
Table 33. VLCD_set bit description	40		
Table 34. I <sup>2</sup> C slave address byte	45		
Table 35. Device protection circuits	48		
Table 36. Limiting values	49		
Table 37. Static characteristics	50		
Table 38. Dynamic characteristics	52		
Table 39. Reducing current consumption	56		
Table 40. 4-bit operation, 1-line display example; using external reset (character set 'A')	60		
Table 41. 8-bit operation, 1-line display example; using external reset (character set 'A')	61		
Table 42. 8-bit operation, 1-line display and icon example; using external reset (character set 'A')	62		
Table 43. 8-bit operation, 2-line display example; using external reset (character set 'A')	63		
Table 44. Example of I <sup>2</sup> C-bus operation; 1-line display (using external reset, assuming pin SA0 = $V_{SS}$ ) <sup>(1)</sup>	64		
Table 45. Initialization by instruction, 8-bit interface <sup>(1)</sup>	66		
Table 46. Initialization by instruction, 4-bit interface; not applicable for I <sup>2</sup> C-bus operation	67		

27. Figures

Fig 1.	Block diagram of PCF2119x	4		
Fig 2.	Pinning diagram of PCF2119x (bare die)	5		
Fig 3.	Electro-optical characteristic: relative transmission curve of the liquid	13		
Fig 4.	Waveforms for the 1:18 multiplex drive mode with 5 bias levels; character mode	14		
Fig 5.	Waveforms for the 1:9 multiplex drive mode with 5 bias levels; character mode, R9 to R16 and R18 open	15		
Fig 6.	Waveforms for the 1:2 multiplex drive mode with 4 bias levels; icon mode	16		
Fig 7.	DDRAM to display mapping: no shift	17		
Fig 8.	DDRAM to display mapping: right shift	17		
Fig 9.	DDRAM to display mapping: left shift	18		
Fig 10.	Character set 'A' in CGROM	19		
Fig 11.	Character set 'D' in CGROM	20		
Fig 12.	Character set 'F' in CGROM	21		
Fig 13.	Character set 'I' in CGROM	22		
Fig 14.	Character set 'R' in CGROM	23		
Fig 15.	Character set 'S' in CGROM	24		
Fig 16.	Relationship between CGRAM addresses, data and display patterns	25		
Fig 17.	Cursor and blink display examples	26		
Fig 18.	Example of displays with icons	26		
Fig 19.	Use of bit P	37		
Fig 20.	Use of bit Q	37		
Fig 21.	Use of bit P and bit Q	37		
Fig 22.	CGRAM to icon mapping (a)	39		
Fig 23.	CGRAM to icon mapping (b)	39		
Fig 24.	4-bit transfer example	42		
Fig 25.	An example of 4-bit data transfer timing sequence	43		
Fig 26.	Example of busy flag checking timing sequence	43		
Fig 27.	System configuration	44		
Fig 28.	Bit transfer	44		
Fig 29.	Definition of START and STOP conditions	44		
Fig 30.	Acknowledgement on the I <sup>2</sup> C-bus	45		
Fig 31.	Master transmits to slave receiver; write mode	46		
Fig 32.	Master reads after setting word address; writes word address, set RS; Read_data	46		
Fig 33.	Master reads slave immediately after first byte; read mode (RS previously defined)	47		
Fig 34.	Parallel bus write operation sequence; writing data from microcontroller to PCF2119x	53		
Fig 35.	Parallel bus read operation sequence; writing data from PCF2119x to microcontroller	53		
Fig 36.	I <sup>2</sup> C-bus timing diagram	54		
Fig 37.	Recommended V <sub>DD</sub> connections for internal V <sub>LCD</sub> generation	55		
Fig 38.	Recommended V <sub>LCD</sub> connections for internal V <sub>LCD</sub> generation	55		
Fig 39.	Recommended V <sub>DD</sub> connections for external V <sub>LCD</sub> generation	55		
Fig 40.	Recommended V <sub>LCD</sub> connections for external V <sub>LCD</sub> generation	55		
Fig 41.	Typical charge pump characteristics (a), V <sub>DD</sub> = 2.2 V	57		
Fig 42.	Typical charge pump characteristics (b), V <sub>DD</sub> = 2.7 V	57		
Fig 43.	Typical charge pump characteristics (c), V <sub>DD</sub> = 4.0 V	58		
Fig 44.	Typical application using parallel interface, 4 or 8 bit bus possible	58		
Fig 45.	Application using I <sup>2</sup> C-bus interface	59		
Fig 46.	Connecting PCF2119x with 2 × 16 character LCD	59		
Fig 47.	Connecting PCF2119x with 1 × 32 character LCD	60		
Fig 48.	User defined euro currency sign	68		
Fig 49.	Bare die outline of PCF2119x	70		
Fig 50.	Details of the 3 inch tray	76		
Fig 51.	Die alignment in the 3 inch tray	77		

## 28. Contents

<b>1</b>	<b>General description</b> . . . . .	<b>1</b>	10.2.3.3	Icon_ctl	37
<b>2</b>	<b>Features and benefits</b> . . . . .	<b>1</b>	10.2.3.4	Temp_ctl	40
<b>3</b>	<b>Applications</b> . . . . .	<b>2</b>	10.2.3.5	HV_gen	40
<b>4</b>	<b>Ordering information</b> . . . . .	<b>3</b>	10.2.3.6	VLCD_set	40
4.1	Ordering options . . . . .	3	<b>11</b>	<b>Basic architecture</b> . . . . .	<b>42</b>
<b>5</b>	<b>Marking</b> . . . . .	<b>3</b>	11.1	Parallel interface . . . . .	42
<b>6</b>	<b>Block diagram</b> . . . . .	<b>4</b>	11.2	I <sup>2</sup> C-bus interface . . . . .	44
<b>7</b>	<b>Pinning information</b> . . . . .	<b>5</b>	11.2.1	I <sup>2</sup> C-bus protocol . . . . .	45
7.1	Pinning . . . . .	5	11.2.2	I <sup>2</sup> C-bus definitions . . . . .	45
7.2	Pin description . . . . .	6	11.3	Safety notes . . . . .	47
<b>8</b>	<b>Functional description</b> . . . . .	<b>8</b>	<b>12</b>	<b>Internal circuitry</b> . . . . .	<b>48</b>
8.1	Oscillator and timing generator . . . . .	8	<b>13</b>	<b>Limiting values</b> . . . . .	<b>49</b>
8.1.1	Timing generator . . . . .	8	<b>14</b>	<b>Static characteristics</b> . . . . .	<b>50</b>
8.1.2	Internal clock . . . . .	8	<b>15</b>	<b>Dynamic characteristics</b> . . . . .	<b>52</b>
8.1.3	External clock . . . . .	8	<b>16</b>	<b>Application information</b> . . . . .	<b>54</b>
8.2	Reset function and Power-On Reset (POR) . . . . .	8	16.1	General application information . . . . .	54
8.3	Power-down mode . . . . .	9	16.2	Power supply connections for internal V <sub>LCD</sub> generation . . . . .	55
8.4	LCD supply voltage generator . . . . .	9	16.3	Power supply connections for external V <sub>LCD</sub> generation . . . . .	55
8.4.1	Programming ranges . . . . .	10	16.4	Information about V <sub>LCD</sub> connections . . . . .	56
8.5	LCD bias voltage generator . . . . .	11	16.5	Reducing current consumption . . . . .	56
8.5.1	Electro-optical performance . . . . .	12	16.6	Charge pump characteristics . . . . .	56
8.6	LCD row and column drivers . . . . .	13	16.7	Interfaces . . . . .	58
<b>9</b>	<b>Display data RAM and ROM</b> . . . . .	<b>17</b>	16.8	Connections with LCD modules . . . . .	59
9.1	DDRAM . . . . .	17	16.9	4-bit operation, 1-line display using external reset . . . . .	60
9.2	CGROM . . . . .	18	16.10	8-bit operation, 1-line display using external reset . . . . .	60
9.3	CGRAM . . . . .	25	16.11	8-bit operation, 2-line display . . . . .	63
9.4	Cursor control circuit . . . . .	26	16.12	I <sup>2</sup> C-bus operation, 1-line display . . . . .	64
<b>10</b>	<b>Registers</b> . . . . .	<b>27</b>	16.13	Initialization . . . . .	66
10.1	Data register . . . . .	28	16.14	User defined characters and symbols . . . . .	67
10.2	Instruction register . . . . .	28	<b>17</b>	<b>Bare die outline</b> . . . . .	<b>70</b>
10.2.1	Basic instructions (bit H = 0 or 1) . . . . .	29	<b>18</b>	<b>Handling information</b> . . . . .	<b>75</b>
10.2.1.1	Function_set . . . . .	29	<b>19</b>	<b>Packing information</b> . . . . .	<b>76</b>
10.2.1.2	BF_AC instructions . . . . .	30	19.1	Packing information on the tray . . . . .	76
10.2.1.3	Read_data . . . . .	31	<b>20</b>	<b>Appendix</b> . . . . .	<b>78</b>
10.2.1.4	Write_data . . . . .	31	20.1	LCD character driver selection . . . . .	78
10.2.2	Standard instructions (bit H = 0) . . . . .	32	<b>21</b>	<b>Abbreviations</b> . . . . .	<b>80</b>
10.2.2.1	Clear_display . . . . .	32	<b>22</b>	<b>References</b> . . . . .	<b>81</b>
10.2.2.2	Return_home . . . . .	32	<b>23</b>	<b>Revision history</b> . . . . .	<b>82</b>
10.2.2.3	Entry_mode_set . . . . .	33	<b>24</b>	<b>Legal information</b> . . . . .	<b>83</b>
10.2.2.4	Display_ctl instructions . . . . .	33	24.1	Data sheet status . . . . .	83
10.2.2.5	Curs_disp_shift . . . . .	34	24.2	Definitions . . . . .	83
10.2.2.6	Set_CGRAM . . . . .	35			
10.2.2.7	Set_DDRAM . . . . .	35			
10.2.3	Extended instructions (bit H = 1) . . . . .	36			
10.2.3.1	Screen_conf . . . . .	36			
10.2.3.2	Disp_conf . . . . .	36			

continued >>

24.3	Disclaimers .....	83
24.4	Trademarks .....	84
<b>25</b>	<b>Contact information .....</b>	<b>84</b>
<b>26</b>	<b>Tables .....</b>	<b>85</b>
<b>27</b>	<b>Figures .....</b>	<b>86</b>
<b>28</b>	<b>Contents .....</b>	<b>87</b>

---

Please be aware that important notices concerning this document and the product(s) described herein, have been included in section 'Legal information'.

---

© NXP Semiconductors N.V. 2015. **All rights reserved.**

For more information, please visit: <http://www.nxp.com>

For sales office addresses, please send an email to: [salesaddresses@nxp.com](mailto:salesaddresses@nxp.com)

Date of release: 16 April 2015

Document identifier: PCF2119X



## Данный компонент на территории Российской Федерации

### Вы можете приобрести в компании MosChip.

Для оперативного оформления запроса Вам необходимо перейти по данной ссылке:

<http://moschip.ru/get-element>

Вы можете разместить у нас заказ для любого Вашего проекта, будь то серийное производство или разработка единичного прибора.

В нашем ассортименте представлены ведущие мировые производители активных и пассивных электронных компонентов.

Нашей специализацией является поставка электронной компонентной базы двойного назначения, продукции таких производителей как XILINX, Intel (ex.ALTERA), Vicor, Microchip, Texas Instruments, Analog Devices, Mini-Circuits, Amphenol, Glenair.

Сотрудничество с глобальными дистрибьюторами электронных компонентов, предоставляет возможность заказывать и получать с международных складов практически любой перечень компонентов в оптимальные для Вас сроки.

На всех этапах разработки и производства наши партнеры могут получить квалифицированную поддержку опытных инженеров.

Система менеджмента качества компании отвечает требованиям в соответствии с ГОСТ Р ИСО 9001, ГОСТ РВ 0015-002 и ЭС РД 009

### Офис по работе с юридическими лицами:

105318, г.Москва, ул.Щербаковская д.3, офис 1107, 1118, ДЦ «Щербаковский»

Телефон: +7 495 668-12-70 (многоканальный)

Факс: +7 495 668-12-70 (доб.304)

E-mail: [info@moschip.ru](mailto:info@moschip.ru)

Skype отдела продаж:

moschip.ru

moschip.ru\_4

moschip.ru\_6

moschip.ru\_9