

Circuits from the Lab™
Reference Circuits

Circuits from the Lab™ reference circuits are engineered and tested for quick and easy system integration to help solve today's analog, mixed-signal, and RF design challenges. For more information and/or support, visit www.analog.com/CN0323.

Devices Connected/Referenced

AD7866	Dual Channel, 1MSPS, 12-bit, Simultaneous Sampling SAR ADC
AD8227	Wide Supply Range, Rail-to-Rail, Instrumentation Amplifier
AD8615	Low Offset, Low Noise, Precision Amplifier

Magnetostrictive Angle Measurement

EVALUATION AND DESIGN SUPPORT

Circuit Evaluation Boards

[CN-0323 Circuit Evaluation Board \(EVAL-CN0323-SDPZ\)](#)
[System Demonstration Platform \(EVAL-SDP-CB1Z\)](#)

Design and Integration Files

[Schematics, Layout Files, Bill of Materials](#)

CIRCUIT FUNCTION AND BENEFITS

The circuit shown in Figure 1 provides a contactless, AMR (anisotropic magnetostrictive) angle measurement solution with 1° angular accuracy over a 180° range. The circuit is ideal for applications where high speed, accurate, non-contact angle measurements are critical.

The circuit provides all necessary signal conditioning including instrumentation amplifiers, buffers, and a dual channel ADC that efficiently process the AMR sensor low level bridge outputs.

The result is an industry leading angle measurement solution suitable for machine tool speed control, crane angle control, motor speed measurement, and other industrial or automotive applications.

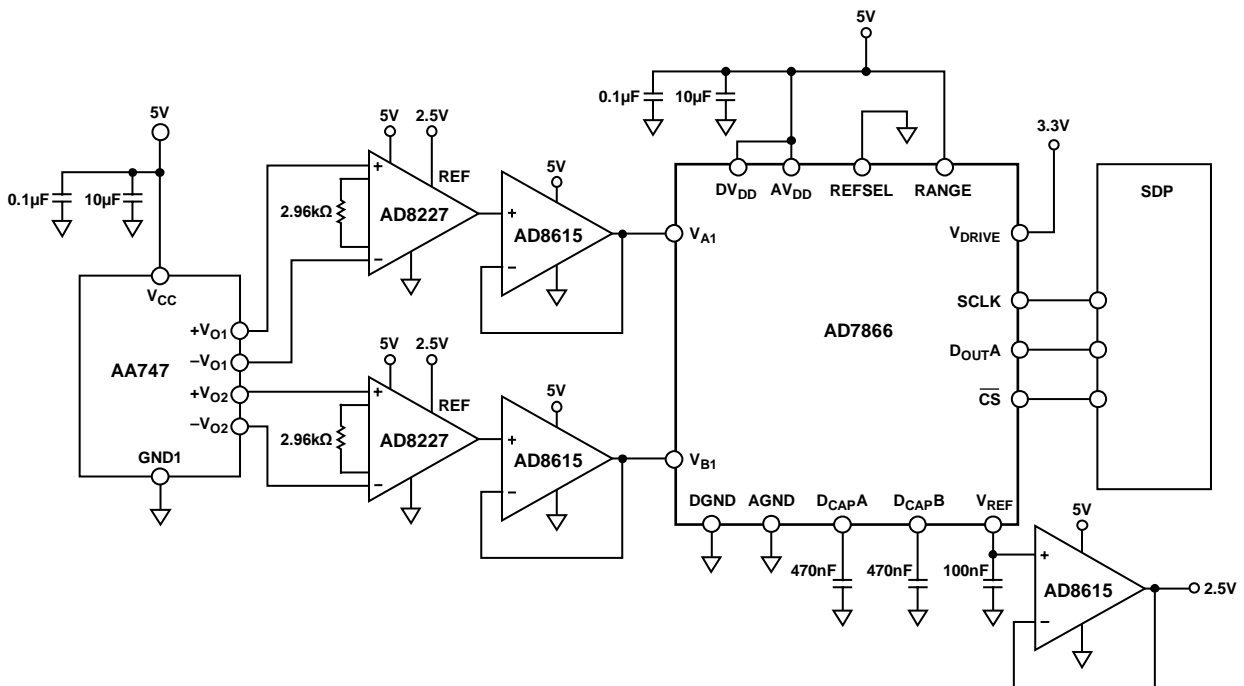

Figure 1. Magnetostrictive Angle Detection System (Simplified Schematic: Decoupling and All Connections Not Shown)

Rev. 0

Circuits from the Lab™ circuits from Analog Devices have been designed and built by Analog Devices engineers. Standard engineering practices have been employed in the design and construction of each circuit, and their function and performance have been tested and verified in a lab environment at room temperature. However, you are solely responsible for testing the circuit and determining its suitability and applicability for your use and application. Accordingly, in no event shall Analog Devices be liable for direct, indirect, special, incidental, consequential or punitive damages due to any cause whatsoever connected to the use of any Circuits from the Lab circuits. (Continued on last page)

CIRCUIT DESCRIPTION

The Sensitec AA747 is an AMR-based angular sensor containing two galvanically separated Wheatstone bridges at a relative angle of 45° to each other. The AA747 offers minimal offset voltage (± 2 mV) and high signal amplitude (65 mV). A rotating magnetic field stimulates the sensor, creating an output voltage of ± 65 mV.

An AD8227 instrumentation amplifier amplifies the signal of interest while rejecting the Wheatstone bridge common-mode voltage of 2.5 V. The common-mode output voltage of the in-amp is set to 2.5 V by driving the V_{REF} pin to 2.5 V. A 2.96 k Ω gain resistor sets the gain of 32. This creates an analog output voltage of 0.2 V to 4.8 V for a bridge output of $2.5 \text{ V} \pm 70$ mV.

The circuit signal bandwidth is determined by the AD8227 that has an approximate 100 kHz bandwidth for a gain of 32

A unity gain AD8615 op amp buffers the in-amp output voltage and connects directly to the ADC. This buffer has a rail-to-rail output stage that swings to within 200 mV of the supply rails.

The AD7866 is a dual channel 12-bit 1 MSPS SAR ADC. The polarity of the RANGE pin determines the analog input range and output coding. If this pin is tied to a logic high when the chip select goes low, the analog input range of the next conversion is 0 V to $2V_{REF}$ (0 V to 5 V), leaving approximately 200 mV headroom for the 0.2 V to 4.8 V input signal from the buffer amplifier.

Connecting the REFSEL pin low configures the ADC to use the internal 2.5 V reference voltage. This voltage is available on the V_{REF} pin but requires a buffer before it can be used elsewhere in the system. The D_{CAPA} pin and D_{CAPB} pin are decoupled with 470 nF capacitors to ensure proper operation of the ADC. The reference voltage is buffered by the AD8615 and sets the common-mode output voltage of the AD8227 in-amp.

The AD7866 simultaneously samples both channels of the magnetoresistive sensor. The digital words are normally available on D_{OUTA} and D_{OUTB} . Each data stream consists of one leading zero followed by three status bits and then twelve bits of conversion data. However, by holding the chip select low for an additional 16 clock cycles, both digital words are read from one channel, D_{OUTA} .

An SPI interface allows access to both channels on one data line.

Magnetostrictive (MR) Theory

Magnetostrictivity is the ability of a material to change the value of its resistance when subjected to an external magnetic field. The most commonly used MR sensors are based on the anisotropic magnetoresistive (AMR) effect.

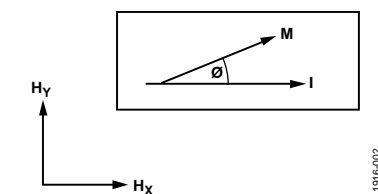

Figure 2. Anisotropic Magnetoresistive Example

An example of the AMR effect is shown in Figure 2. A current (I), flowing through a conductor, is subject to an external magnetic field (H_Y). The resistance of the conductor changes as a function of the angle (θ) between the magnetization vector (M) and the current flow vector (I). The magnetization vector is the net sum of the internal magnetic field (H_X) and the applied external magnetic field (H_Y).

The maximum resistance occurs when the magnetization vector (M) is parallel to the current vector (I). The minimum resistance occurs when the magnetization vector (M) is perpendicular to the current vector (I).

Effective utilization of the AMR effect requires the conductor itself to be a material insensitive to mechanical stress but sensitive to magneto-restriction. For these reasons, permalloy (80% nickel, 20% iron) is the most commonly used alloy in AMR sensor manufacturing.

Permalloy Properties

There are two properties of permalloy strips that provide design challenges when creating angular measurement systems.

First, permalloy has a narrow linear operating region (see Figure 3). Only when the angle (θ) between the magnetization vector (M) and current flow vector (I) becomes larger, does the response become linear. Unfortunately, shortly after the response becomes linear, it will saturate.

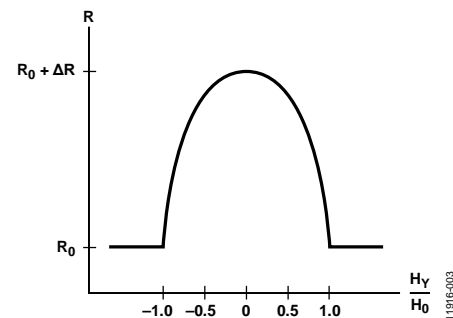

Figure 3. Permalloy Resistance vs. Magnetic Field

Secondly, permalloy is insensitive to polarity. The resistance of a permalloy strip decreases whether the angle (θ) between the magnetization vector (M) and the current flow vector (I) is positive or negative.

Barber Poles

A common method used to improve both the linearity and polar insensitivity of the permalloy strip is to add aluminum stripes angled at 45° to the strip axis called barber poles, as shown in Figure 4. Any current flowing between barber poles takes the shortest path—the perpendicular path, and the angle between the current flow vector (I) and magnetization vector (M) shifts by 45° .

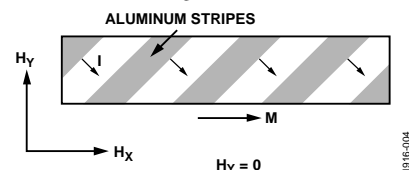

Figure 4. Barber Pole Effect in a Permalloy Strip

Figure 5 shows the result of adding Barber Poles to a permalloy strip. The current flow vector shifts by 45°, but the magnetization vector remains unchanged. Notice the linear behavior now present in the middle of the graph.

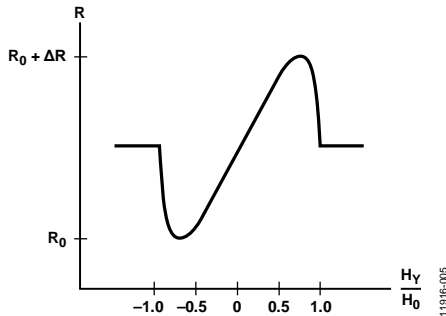

Figure 5. Barber Pole Permalloy Resistance vs. Magnetic Field

Magnetic Field Strength

The AA747 magnetoresistive sensor requires a minimum magnetic field strength of 25 kA/m to ensure the error specification found in the data sheet. This stimulating magnetic field must intersect the center of the sensor package.

When selecting a magnet, consider the air gap between the sensor and the magnet as shown in Figure 6. If the magnet is not in close proximity to the sensor (the distance, d, is very large), a larger magnetic field strength may be necessary to ensure the magnetic field strength at the sensor location and maintain the minimum error specification.

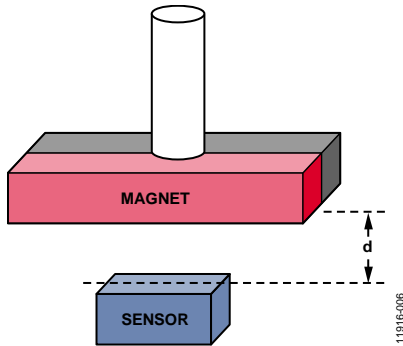

Figure 6. Magnet Orientation and Air Gap for Rotating Shaft Angle Measurement.

Sensor Basics

The standard AMR sensor consists of two Wheatstone bridges, with one bridge at a relative angle of 45° with respect to the other. Permalloy strips comprise each element of both bridges and have nominal resistance values of 3.2 kΩ.

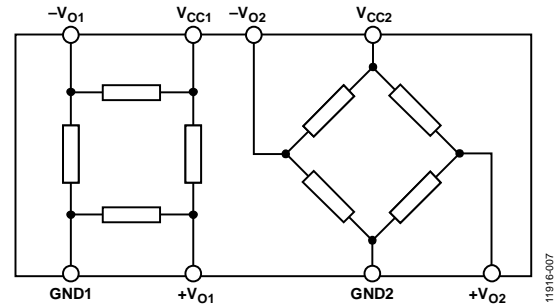

Figure 7. AA747 Dual Wheatstone Bridge Configuration

The maximum peak signal amplitude of the AA747 is 70 mV (14 mV/V_{CC} on a 5 V supply). The sensor offset voltage is ±10 mV (±2 mV/V_{CC} on a 5 V supply) giving a useable 2.5 V ±0.70 mV output signal. A rotating magnetic field produces the sin(2θ) and cos(2θ) outputs seen in Figure 8. Both signals are periodic over a 180° range, making the detection of full 360° measurements impossible without additional circuitry and components.

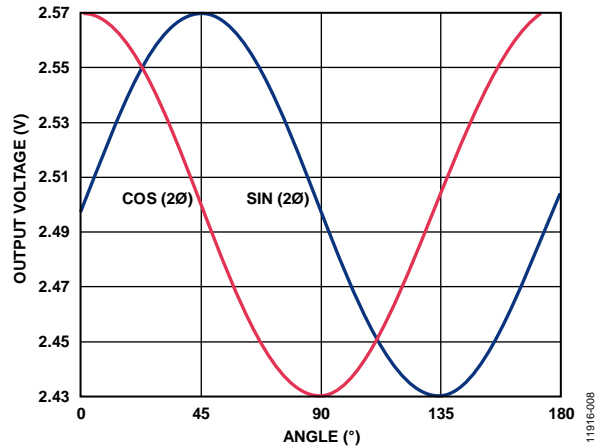

Figure 8. Magnetoresistive Sensor Output Voltage

Channel Sensitivity

The sensor has a nominal sensitivity of 2.35 mV/° for each channel. This means each degree of change between the magnetization vector and the sensor orientation produces an output voltage change of 2.35 mV. The sensitivity is not constant with respect to the angle. The areas of decreased sensitivity are the portions of each output where the slope of the line approaches zero.

Referring to Figure 8, channel one (the blue line) loses sensitivity as the magnetization vector angle nears 45° or 135°. Similarly, channel two (the red line) loses sensitivity around 0° and 90°. Fortunately, when one channel has reduced sensitivity, the other channel is in a region of high sensitivity.

The software takes advantage of this, measuring the angle based on whichever sensor is most accurate at the time. If channel one is approaching 45°, channel two is used to calculate the angle and maintain the system accuracy.

System Bandwidth, Magnetic Field Rotation

The angular velocity of the magnetic field is an important component in understanding the bandwidth of the circuit. The ADC converts one sample every microsecond. In order to achieve a resolution of 1°, the magnetic field can only move one degree in one microsecond (2.778 kHz); otherwise, the ADC cannot sample fast enough to keep up with the magnetic field. This sets the maximum useable angular velocity of the magnetic field at 2.778 kHz for a 1 MSPS ADC.

Test Results

The EVAL-CN0323-SDPZ PCB is tested by mounting a magnet to the end face of a rod capable of spinning freely through 360°. The EVAL-CN0323-SDPZ PCB sits in position with the face of the AA747 AMR sensor (U5) parallel to the face of the magnet. The EVAL-CN0189-SDPZ tilt sensor PCB attaches to the second end of the rod. Thus, as the rod spins, both CN-0189 and the magnet also spin through 360°. A functional diagram of the setup is shown in Figure 9, and a photo of the setup is shown in Figure 10.

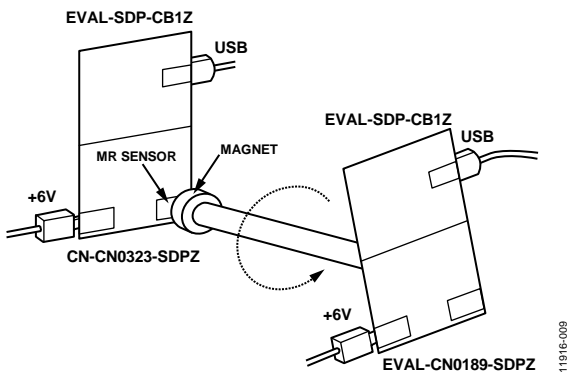

Figure 9. Data Collection Test Setup

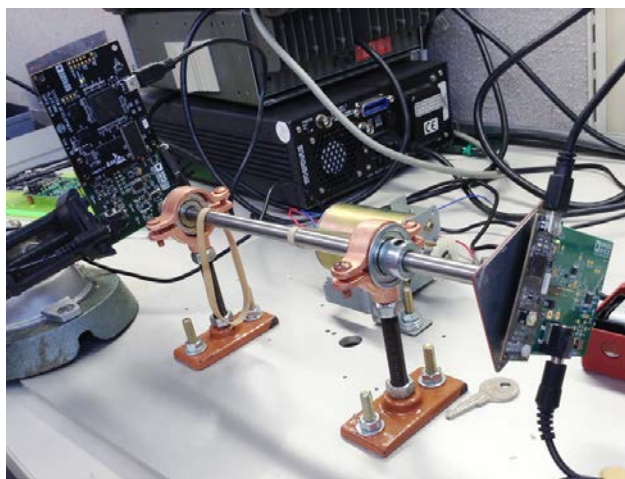

Figure 10. Photo of Bench Test Setup

The CN-0189 tilt measurement system provides a reference angle to test CN-0323. The center rod turns until the CN-0189 evaluation software reads 0°. The center rod is held in this

position while the magnet is rotated to produce a 0° angle reading in the CN-0323 evaluation software.

It is important to align the center of the magnet with the center of the face of the IC. Any misalignment shifts the magnetic field with respect to the sensor and cause errors in the final angle calculation of the CN-0323 evaluation software.

Data is collected by turning the center rod and comparing the two evaluation software display readings. Figure 11 shows the output angle error recorded through a ±90° range. The error is ±0.4° over the entire range. The LabVIEW evaluation software can be seen in Figure 12.

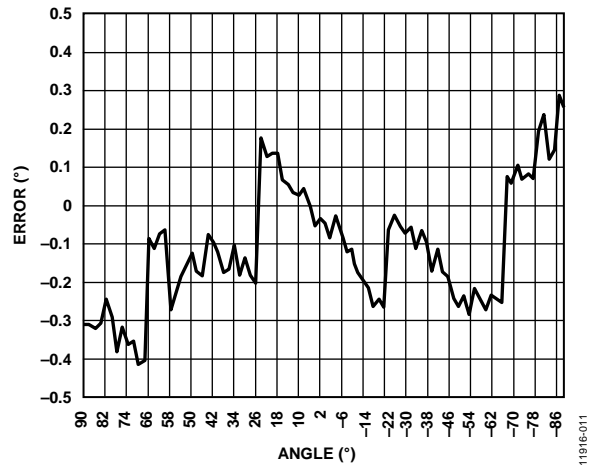

Figure 11. Magnetic Field Angle Error

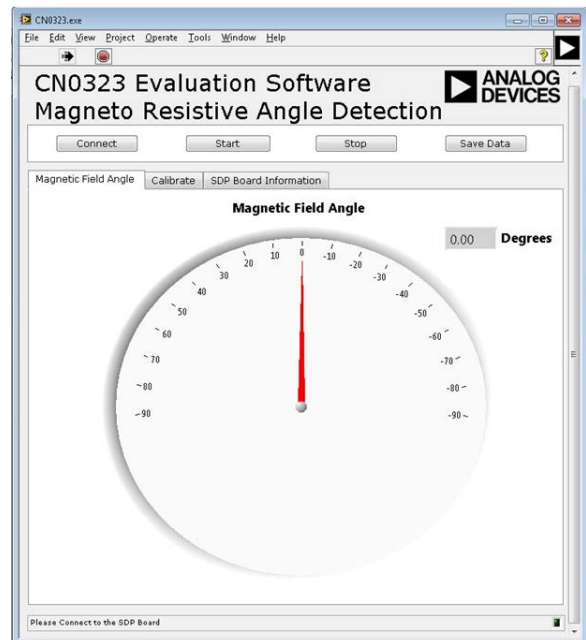

Figure 12. Screenshot of the CN-0323 evaluation software

The calibration tab determines the maximum and minimum voltage (V_{MAX} and V_{MIN}) output of each Wheatstone bridge. Knowing these values allows a more precise mapping of voltage to digital code. The user has two methods of determining the V_{MAX} and V_{MIN} values.

The first method is manually entering the values. The second method is to spin the magnet through a 180° range while the software automatically identifies the values. This method can be faster than manually identifying the values but can also introduce errors if the magnetic field is rotating too quickly.

PCB Layout Considerations

In any circuit where accuracy is crucial, it is important to consider the power supply and ground return layout on the board. The PCB should isolate the digital and analog sections as much as possible. The PCB for this system was constructed in a 4-layer stack up with large area ground plane layers and power plane polygons. See the [MT-031 Tutorial](#) for more discussion on layout and grounding, and the [MT-101 Tutorial](#) for information on decoupling techniques.

Decouple the power supply to all ICs with 1 μF and 0.1 μF capacitors to properly suppress noise and reduce ripple. Place the capacitors as close to the device as possible. Ceramic capacitors are advised for all high frequency decoupling.

Power supply lines should have as large a trace width as possible to provide low impedance paths and reduce glitch effects on the supply line. Shield clocks and other fast switching digital signals from other parts of the board by digital ground. Figure 13 is a photo of the PCB.

A complete design support package for this circuit note is at www.analog.com/CN0323-DesignSupport.

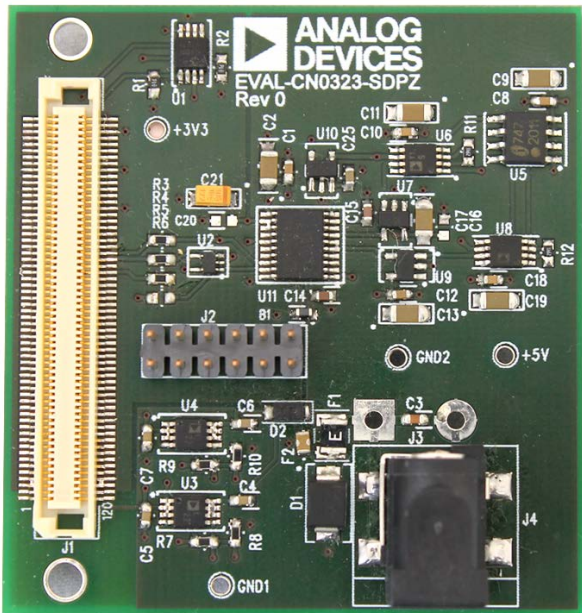

Figure 13. Photo of the [EVAL-CN0323-SDPZ](#) PCB

COMMON VARIATIONS

Two changes are required to create a linear position measurement system. First, replace the AA747 AMR sensor with the AA745. This sensor specifically senses linear movement and has identical electrical characteristics as the AA747. Second, replace the magnet with a multi-pole bar magnet consisting of a series of alternating north and south poles as shown in Figure 14.

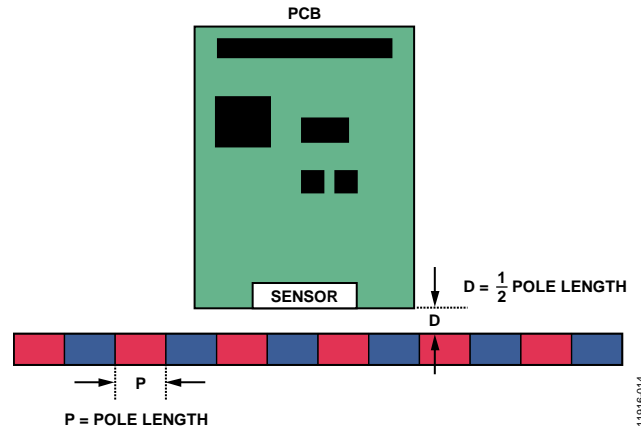

Figure 14. Linear Position Measurement Magnet, PCB, and Sensor

The AA745 comes in a horizontal package that mounts flush against the edge of the PCB. This allows optimization of the distance between the magnet and sensor, the ideal distance being one-half the pole length of the magnet.

As the sensor moves parallel to the magnet it detects the magnetic field which rotates 180° for every pole length travelled. The pole length of the magnet (P) and the angular accuracy of the sensor ($\Delta\theta = 0.05^\circ$) determine the theoretical accuracy (Δx).

$$\Delta x = P \times \Delta\theta / 180^\circ$$

This provides an absolute measurement system for only one pole length. If the magnet has more than one pole, counting the number of poles passed provides a more accurate reading. Additional electronics are required to implement this functionality, and traditionally a second magnet with different pole length provides a reference point for an additional sensor.

CIRCUIT EVALUATION AND TEST

This circuit uses the [EVAL-SDP-CB1Z](#) System Demonstration Platform (SDP) evaluation board and the [EVAL-CN0323-SDPZ](#) circuit board. The two boards have 120-pin mating connectors, allowing for the quick setup and evaluation of the performance of the circuit.

The [EVAL-CN0323-SDPZ](#) contains the circuit to be evaluated, as described in this note. The [EVAL-SDP-CB1Z](#) is used with the [CN-0323 evaluation software](#) to capture the data from the [EVAL-CN0323-SDPZ](#) evaluation board.

Equipment Needed

The following equipment is needed:

- PC with a USB port and Windows® XP or Windows Vista® (32-bit), or Windows® 7 (32-bit)
- [EVAL-CN0323-SDPZ](#) evaluation board
- [EVAL-SDP-CB1Z](#) evaluation board
- 6 V power supply or wall wart
- [CN-0323 evaluation software](#)
- Neodymium magnet with a minimum magnetic field strength of 25kA/m at the package of the sensor.

Getting Started

Load the evaluation software by placing the [CN-0323 evaluation software](#) CD into the PC. Using **My Computer**, locate the drive that contains the evaluation software CD and open the **Readme** file. Follow the instructions contained in the **Readme** file for installing and using the evaluation software.

Functional Block Diagram

Figure 15 shows the functional block diagram of the test setup.

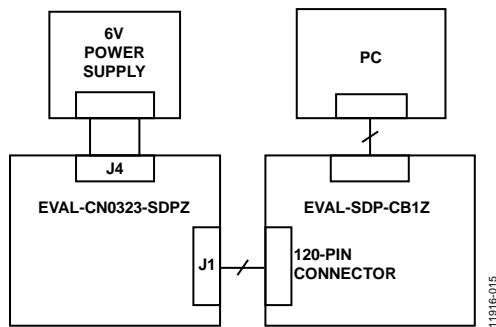

Figure 15. Test Setup Block Diagram

Setup

Connect the 120-pin connector on the [EVAL-CN0323-SDPZ](#) to the connector on the [EVAL-SDP-CB1Z](#). Use nylon hardware to firmly secure the two boards, using the holes provided at the ends of the 120-pin connectors.

With power to the supply off, connect a 6.0 V DC barrel jack to connector J4. Connect the USB cable supplied with the [EVAL-SDP-CB1Z](#) to the USB port on the PC. Note: Do not connect the USB cable to the mini-USB connector on the SDP board at this time.

Place the neodymium magnet directly on top of the IC or in some fixture designed to spin the magnet, which minimizes the distance between the IC and magnet itself.

It is important to keep other sources of magnetic fields away from the IC as any stray magnetic field can cause errors in the output voltage of the sensor.

Test

Apply power to the DC barrel jack, connector J4. Launch the [CN-0323 evaluation software](#) and connect the USB cable from the PC to the mini-USB connector on the [EVAL-SDP-CB1Z](#).

Once USB communications are established, the [EVAL-SDP-CB1Z](#) can now be used to send, receive, and capture serial data from the [EVAL-CN0323-SDPZ](#).

Information regarding the [EVAL-SDP-CB1Z](#) can be found in the [SDP User Guide](#).

Information and details regarding test setup and calibration, and how to use the evaluation software for data capture can be found in the [CN-0323 Software User Guide](#) at: www.analog.com/CN0323-UserGuide.

LEARN MORE

CN-0323 Design Support Package:

<http://www.analog.com/CN0323-DesignSupport>

MT-031 Tutorial, *Grounding Data Converters and Solving the Mystery of “AGND” and “DGND”*, Analog Devices.

MT-101 Tutorial, *Decoupling Techniques*, Analog Devices.

AN-688 Application Note, *Phase and Frequency Response of iMEMS Accelerometers and Gyros*, Analog Devices

AA700 Application Note, *AMR Freepitch Sensors for Angle and Length Measurement*, Sensitec

Data Sheets and Evaluation Boards

[CN-0323 Circuit Evaluation Board \(EVAL-CN0323-SDPZ\)](#)

[System Demonstration Platform \(EVAL-SDP-CB1Z\)](#)

[AD7866 Data Sheet](#)

[AD8227 Data Sheet](#)

[AD8615 Data Sheet](#)

REVISION HISTORY

10/13—Rev. 0: Initial Version

(Continued from first page) Circuits from the Lab circuits are intended only for use with Analog Devices products and are the intellectual property of Analog Devices or its licensors. While you may use the Circuits from the Lab circuits in the design of your product, no other license is granted by implication or otherwise under any patents or other intellectual property by application or use of the Circuits from the Lab circuits. Information furnished by Analog Devices is believed to be accurate and reliable. However, Circuits from the Lab circuits are supplied "as is" and without warranties of any kind, express, implied, or statutory including, but not limited to, any implied warranty of merchantability, noninfringement or fitness for a particular purpose and no responsibility is assumed by Analog Devices for their use, nor for any infringements of patents or other rights of third parties that may result from their use. Analog Devices reserves the right to change any Circuits from the Lab circuits at any time without notice but is under no obligation to do so.

Данный компонент на территории Российской Федерации

Вы можете приобрести в компании MosChip.

Для оперативного оформления запроса Вам необходимо перейти по данной ссылке:

<http://moschip.ru/get-element>

Вы можете разместить у нас заказ для любого Вашего проекта, будь то серийное производство или разработка единичного прибора.

В нашем ассортименте представлены ведущие мировые производители активных и пассивных электронных компонентов.

Нашей специализацией является поставка электронной компонентной базы двойного назначения, продукции таких производителей как XILINX, Intel (ex.ALTERA), Vicor, Microchip, Texas Instruments, Analog Devices, Mini-Circuits, Amphenol, Glenair.

Сотрудничество с глобальными дистрибьюторами электронных компонентов, предоставляет возможность заказывать и получать с международных складов практически любой перечень компонентов в оптимальные для Вас сроки.

На всех этапах разработки и производства наши партнеры могут получить квалифицированную поддержку опытных инженеров.

Система менеджмента качества компании отвечает требованиям в соответствии с ГОСТ Р ИСО 9001, ГОСТ РВ 0015-002 и ЭС РД 009

Офис по работе с юридическими лицами:

105318, г.Москва, ул.Щербаковская д.3, офис 1107, 1118, ДЦ «Щербаковский»

Телефон: +7 495 668-12-70 (многоканальный)

Факс: +7 495 668-12-70 (доб.304)

E-mail: info@moschip.ru

Skype отдела продаж:

moschip.ru

moschip.ru_4

moschip.ru_6

moschip.ru_9