



DS31415

3-Input, 4-Output, Single DPLL Timing IC with Sub-ps Output Jitter and 1588 Clock

General Description

The DS31415 is a flexible, high-performance timing IC for diverse frequency conversion and frequency synthesis applications. On each of its three input clocks and four output clocks, the device can accept or generate nearly any frequency between 2kHz and 750MHz.

The input clocks are divided down, fractionally scaled as needed, and continuously monitored for activity and frequency accuracy. The best input clock is selected, manually or automatically, as the reference clock for the rest of the device. A flexible, high-performance digital PLL locks to the selected reference and provides programmable bandwidth, very high resolution holdover capability, and truly hitless switching between input clocks. The digital PLL is followed by a clock synthesis subsystem that has two fully programmable digital frequency synthesis blocks, a high-speed low-jitter APLL, and four output clocks, each with its own 32-bit divider and phase adjustment. The APLL provides fractional scaling and output jitter less than 1ps RMS. For telecom systems, the DS31415 has all required features and functions to serve as a central timing function or as a line card timing IC.

In addition the DS31415 has an embedded IEEE 1588 clock that can be steered by system software to follow a time master elsewhere in the system or elsewhere in the network. This clock has all necessary features to be the central time clock in a 1588 ordinary clock, boundary clock or transparent clock.

Applications

Frequency Conversion and IEEE1588 Time/Frequency Applications in a Wide Variety of Equipment Types

Telecom Line Cards or Timing Cards with Any Mix of SONET/SDH, Synchronous Ethernet and/or OTN Ports in WAN Equipment Including MSPPs, Ethernet Switches, Routers, DSLAMs, and Base Stations

Ordering Information

PART	TEMP RANGE	PIN-PACKAGE
DS31415GN+	-40°C to +85°C	256 CSBGA

+Denotes a lead(Pb)-free/RoHS-compliant package.
SPI is a trademark of Motorola, Inc.

Features

- ◆ **Three Input Clocks**
 - ◆ Differential or CMOS/TTL Format
 - ◆ Any Frequency from 2kHz to 750MHz
 - ◆ Fractional Scaling for 64B/66B and FEC Scaling (e.g., 64/66, 237/255, 238/255) or Any Other Downscaling Requirement
 - ◆ Continuous Input Clock Quality Monitoring
 - ◆ Three 2/4/8kHz Frame Sync Inputs
- ◆ **High-Performance DPLL**
 - ◆ Hitless Reference Switching on Loss of Input
 - ◆ Automatic or Manual Phase Build-Out
 - ◆ Holdover on Loss of All Inputs
 - ◆ Programmable Bandwidth, 0.5mHz to 400Hz
- ◆ **Two Digital Frequency Synthesizers**
 - ◆ Produce Any 2kHz Multiple Up to 77.76MHz
 - ◆ Per-DFS Phase Adjustment
- ◆ **High-Performance Output APLL**
 - ◆ Output Frequencies to 750MHz
 - ◆ High Resolution Fractional Scaling for FEC and 64B/66B (e.g., 255/237, 255/238, 66/64) or Any Other Scaling Requirement
 - ◆ Less than 1ps RMS Output Jitter
- ◆ **Four Output Clocks in Two Groups**
 - ◆ Nearly Any Frequency from < 1Hz to 750MHz
 - ◆ Each Group Slaves to a DFS Clock, Any APLL Clock, or Any Input Clock (Divided and Scaled)
 - ◆ Each Has a Differential Output (3 CML, 4 LVDS/LVPECL) and Separate CMOS/TTL Output
 - ◆ 32-Bit Frequency Divider Per Output
 - ◆ Two Sync Pulse Outputs: 8kHz and 2kHz
- ◆ **IEEE 1588 Clock Features**
 - ◆ Steerable by Software with 2⁻⁸ns Time Resolution and 2⁻³²ns Frequency Resolution
 - ◆ 4ns Input Timestamp Accuracy and Output Edge Placement Accuracy
 - ◆ Programmable Clock and Time-Alignment I/O to Synchronize All 1588 Devices in Large Systems
 - ◆ Supports 1588 OC, BC, and TC Architectures
- ◆ **General Features**
 - ◆ Suitable Line Card IC or Timing Card IC for Stratum 2/3E/3/4E/4, SMC, SEC/EEC, or SSU
 - ◆ Accepts and Produces Nearly Any Frequency from 1Hz Up to 750MHz
 - ◆ Internal Compensation for Local Oscillator Frequency Error
 - ◆ SPI™ Processor Interface
 - ◆ 1.8V Operation with 3.3V I/O (5V Tolerant)

Application Example

Typical Application Example, Traditional Frequency Synchronization

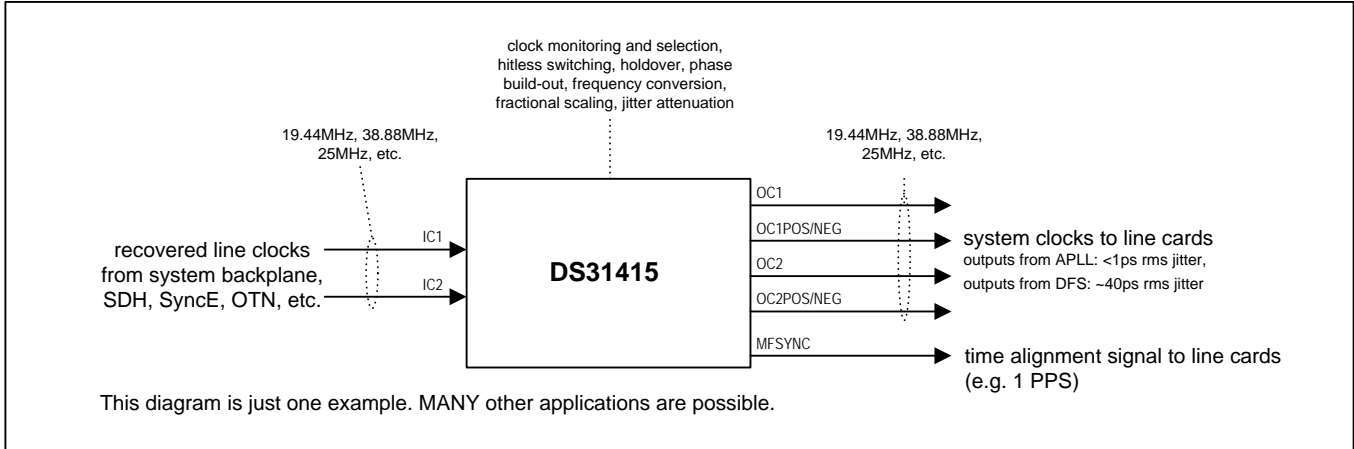

Typical Application Example, Frequency and Time Synchronization

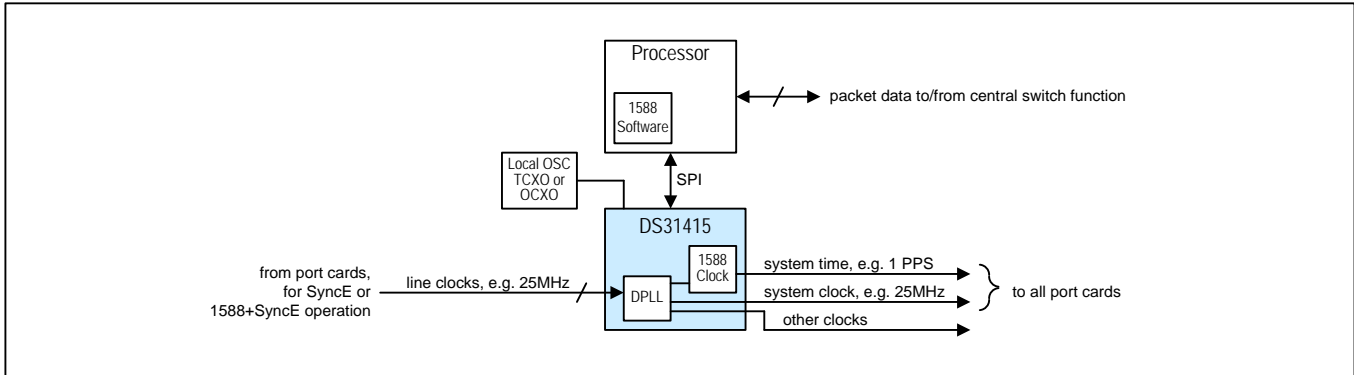

Block Diagram

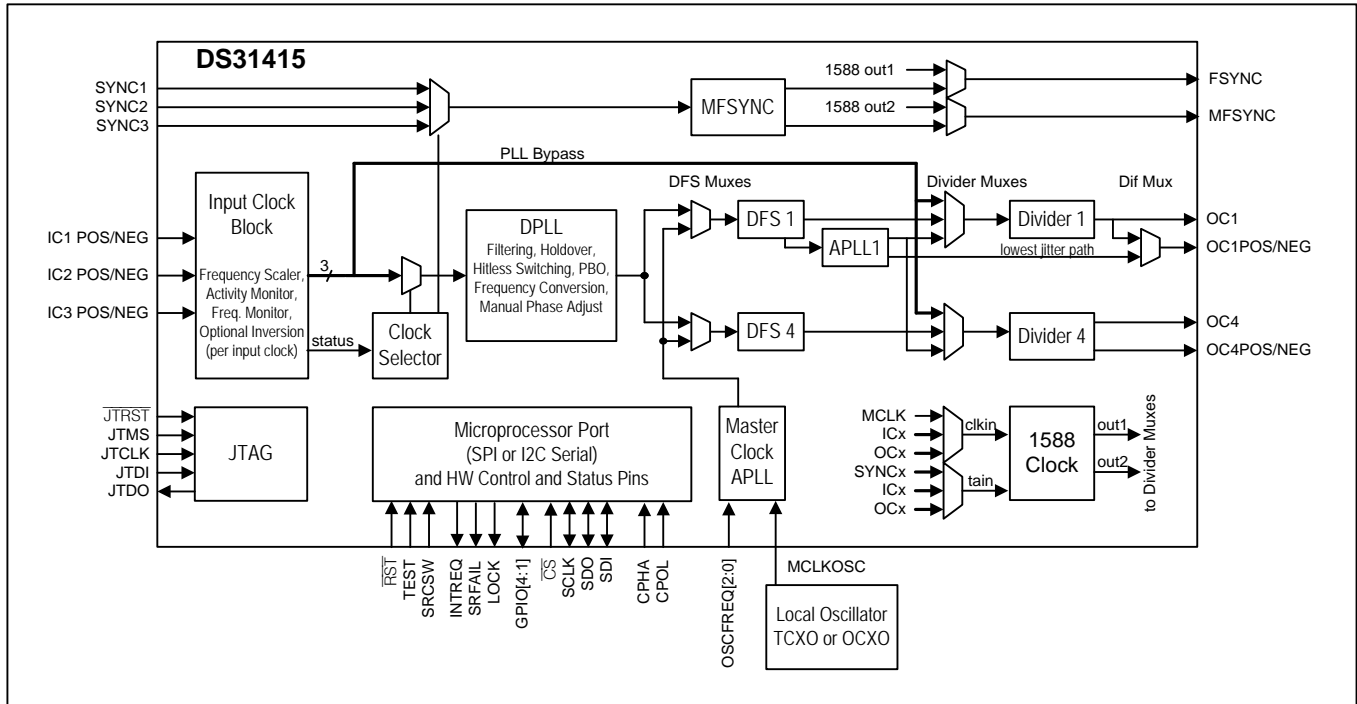

Detailed Features

Input Clock Features

- Three input clocks, differential or CMOS/TTL signal format
- Input clocks can be any frequency from 2kHz up to 750MHz
- Per-input fractional scaling (i.e., multiplying by N/D where N is a 16-bit integer and D is a 32-bit integer and $N < D$) to undo 64B/66B and FEC scaling (e.g., 64/66, 238/255, 237/255, 236/255)
- Special mode allows locking to 1Hz input clocks
- All inputs constantly monitored by programmable activity monitors and frequency monitors
- Fast activity monitor can disqualify the selected reference after a few missing clock cycles
- Frequency measurement and frequency monitor thresholds with 0.2ppm resolution
- Three optional 2/4/8kHz frame-sync inputs

DPLL Features

- Very high-resolution DPLL architecture
- Sophisticated state machine automatically transitions between free-run, locked, and holdover states
- Revertive or nonrevertive reference selection algorithm
- Programmable bandwidth from 0.5mHz to 400Hz
- Separately configurable acquisition bandwidth and locked bandwidth
- Programmable damping factor to balance lock time with peaking: 1.2, 2.5, 5, 10, or 20
- Multiple phase detectors: phase/frequency and multicycle
- Phase/frequency locking ($\pm 360^\circ$ capture) or nearest edge phase locking ($\pm 180^\circ$ capture)
- Multicycle phase detection and locking (up to ± 8191 UI) improves jitter tolerance and lock time
- Phase build-out in response to reference switching for true hitless switching
- Less than 1ns output clock phase transient during phase build-out
- Output phase adjustment up to ± 200 ns in 6ps steps with respect to selected input reference
- High-resolution frequency and phase measurement
- Holdover frequency averaging over 1-second, 5.8-minute, and 93.2-minute intervals
- Fast detection of input clock failure and transition to holdover mode
- Low-jitter frame sync (8kHz) and multiframe sync (2kHz) aligned with output clocks

Digital Frequency Synthesizer Features

- Two independently programmable DFS engines
- Each DFS can synthesize any 2kHz multiple up to 77.76MHz
- Per-DFS phase adjust (1/256UI steps)
- Approximately 40ps RMS output jitter

Output APLL Features

- Simultaneously produce four different output frequencies from the same reference clock
- Standard telecom output frequencies include 622.08MHz, 155.52MHz, and 19.44MHz for SONET/SDH and 156.25MHz, 125MHz, and 25MHz for Synchronous Ethernet
- Very high-resolution fractional scaling (i.e., noninteger multiplication)
- Less than 1ps RMS output jitter

Output Clock Features

- Four output clock signals in two groups
- Output clock group OC1 has a very high-speed differential output (current-mode logic, $\leq 750\text{MHz}$) and a separate CMOS/TTL output ($\leq 125\text{MHz}$)
- Output clock group OC4 has a high-speed differential output (LVDS/LVPECL, $\leq 312.5\text{MHz}$) and a separate CMOS/TTL output ($\leq 125\text{MHz}$)
- Each output can be any frequency from $< 1\text{Hz}$ to max frequency stated above
- Supported telecom frequencies include PDH, SDH, Synchronous Ethernet, OTN, microprocessor clock frequencies, and much more
- Internal clock muxing allows each output group to slave to its associated DFS block, an APLL output, or any input clock (after being divided and scaled)
- Outputs sourced directly from the APLL have less than 1ps RMS output jitter
- Outputs sourced directly from DFS engines have approximately 40ps RMS output jitter
- Optional 32-bit frequency divider per output
- 8kHz frame sync and 2kHz multiframe sync outputs have programmable polarity and pulse width and can be disciplined by a 2kHz or 8kHz frame sync input
- Per-output delay adjustment
- Per-output enable/disable
- All outputs disabled during reset

1588 Clock Features

- Initialized and steered by software on an external processor to follow an external 1588 master
- 2^{-8}ns time resolution and 2^{-32}ns frequency resolution
- 4ns accuracy for input signal timestamping and output signal edge placement
- Three time/frequency controls: direct time write, high-resolution frequency adjustment, and time adjustment (i.e., frequency adjustment for an exact duration to achieve gradual, precise time change)
- Programmable clock and time-alignment I/O to synchronize all 1588 elements in large systems
 - Can frequency-lock to an input clock signal from a master elsewhere in the system
 - Can timestamp (TS) an input alignment signal to time-lock to a master elsewhere in the system (e.g., 1PPS)
 - Can provide an output clock signal to slave components elsewhere in the system (e.g., 25MHz)
 - Can provide an output time alignment signal to slaves elsewhere in the system (e.g., 1PPS)
- Two flexible programmable event generators (PEG) can output one pulse per second (1PPS), one pulse per period, and a wide variety of clock signals
- Full support for dual redundant timing cards for high-reliability, fault-tolerant systems
- Compatible with a wide variety of 1588 system architectures for 1588 ordinary clocks, boundary clocks and transparent clocks

General Features

- SPI serial microprocessor interface
- Four general-purpose I/O pins
- Register set can be write protected
- Operates from a 12.8MHz, 25.6MHz, 10.24MHz, 20.48MHz, 10MHz, 20MHz, 19.44MHz, or 38.88MHz local oscillator
- On-chip watchdog circuit for the local oscillator
- Internal compensation for local oscillator frequency error



Microsemi Corporate Headquarters
One Enterprise, Aliso Viejo CA 92656 USA
Within the USA: +1 (949) 380-6100
Sales: +1 (949) 380-6136
Fax: +1 (949) 215-4996

Microsemi Corporation (NASDAQ: MSCC) offers a comprehensive portfolio of semiconductor solutions for: aerospace, defense and security; enterprise and communications; and industrial and alternative energy markets. Products include high-performance, high-reliability analog and RF devices, mixed signal and RF integrated circuits, customizable SoCs, FPGAs, and complete subsystems. Microsemi is headquartered in Aliso Viejo, Calif. Learn more at www.microsemi.com.

© 2012 Microsemi Corporation. All rights reserved. Microsemi and the Microsemi logo are trademarks of Microsemi Corporation. All other trademarks and service marks are the property of their respective owners.

Данный компонент на территории Российской Федерации

Вы можете приобрести в компании MosChip.

Для оперативного оформления запроса Вам необходимо перейти по данной ссылке:

<http://moschip.ru/get-element>

Вы можете разместить у нас заказ для любого Вашего проекта, будь то серийное производство или разработка единичного прибора.

В нашем ассортименте представлены ведущие мировые производители активных и пассивных электронных компонентов.

Нашей специализацией является поставка электронной компонентной базы двойного назначения, продукции таких производителей как XILINX, Intel (ex.ALTERA), Vicor, Microchip, Texas Instruments, Analog Devices, Mini-Circuits, Amphenol, Glenair.

Сотрудничество с глобальными дистрибьюторами электронных компонентов, предоставляет возможность заказывать и получать с международных складов практически любой перечень компонентов в оптимальные для Вас сроки.

На всех этапах разработки и производства наши партнеры могут получить квалифицированную поддержку опытных инженеров.

Система менеджмента качества компании отвечает требованиям в соответствии с ГОСТ Р ИСО 9001, ГОСТ РВ 0015-002 и ЭС РД 009

Офис по работе с юридическими лицами:

105318, г.Москва, ул.Щербаковская д.3, офис 1107, 1118, ДЦ «Щербаковский»

Телефон: +7 495 668-12-70 (многоканальный)

Факс: +7 495 668-12-70 (доб.304)

E-mail: info@moschip.ru

Skype отдела продаж:

moschip.ru

moschip.ru_4

moschip.ru_6

moschip.ru_9