

NOTES: UNLESS OTHERWISE SPECIFIED

1. CORNERS DRAWN SHARP TO BE R.005 MAXIMUM.
2. EXTERIOR SURFACE TEXTURE TO BE EQUIVALENT TO MT-11007. TEXTURE ON ENCLOSURE WILL VARY FROM TIME TO TIME AS THE TOOL WEARS AND IT BECOMES NECESSARY TO REAPPLY.
3. INTERIOR SURFACE TEXTURE TO BE: NONE.
4. ALL INSIDE RADII .010R. UNLESS OTHERWISE SPECIFIED.
5. ALL EXTERNAL DIMENSIONS AFFECTED BY THE DRAFT APPLY AT THE LARGE END OF THE FEATURE, AND ALL INTERNAL FEATURES AFFECTED BY THE DRAFT APPLY AT THE SMALL END OF THE FEATURE UNLESS OTHERWISE SPECIFIED.
6. 1 DEGREE DRAFT IN THE DIRECTION OF PULL IS PERMISSIBLE UNLESS OTHERWISE SPECIFIED.
7. MATERIAL / COLOR: ABS PLASTIC IS STANDARD IN BLACK OR WHITE. CUSTOM MATERIALS AND COLORS ARE AVAILABLE UPON REQUEST FOR QUOTE. ALTERNATE RESINS HAVE DIFFERENT SHRINK RATES, AND WILL EFFECT DIMENSIONS.
8. PCB SIZES ARE RECOMMENDATIONS ONLY. FINAL SIZES AND VERIFICATION OF ITS FIT ARE THE SOLE RESPONSIBILITY OF EACH CUSTOMER.
9. ASSEMBLY SCREWS FOR THE ENCLOSURE INCLUDED.
10. THIS DRAWING IS BASED ON A SOLID MODEL, AND IS FURTHER DEFINED BY THE SOLID MODEL FILE.
11. ALLOWABLE FLASH: 0.005 MAX.
12. ALL EJECTOR PIN MARKS TO BE WITHIN 0.010" OF FLUSH, PROTRUDING OR BELOW FLUSH.
14. TRIM GATE WITHIN 0.030" OF FLUSH.

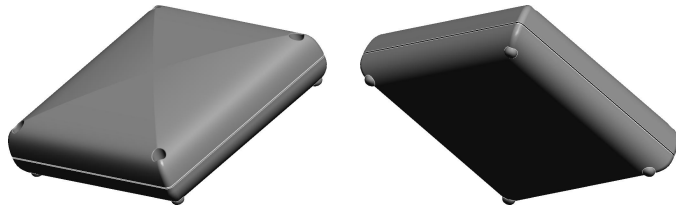

SCALE 0.250

R E V I S I O N					
REV.	DRAWN BY	ECO No	DESCRIPTION	DATE	APPROVED
A	M BOYER		PRELIMINARY RELEASE	2015-Feb-12	J.T.
B	M BOYER		REVISE PROJECT NAME AND NOTES	2015-Feb-25	

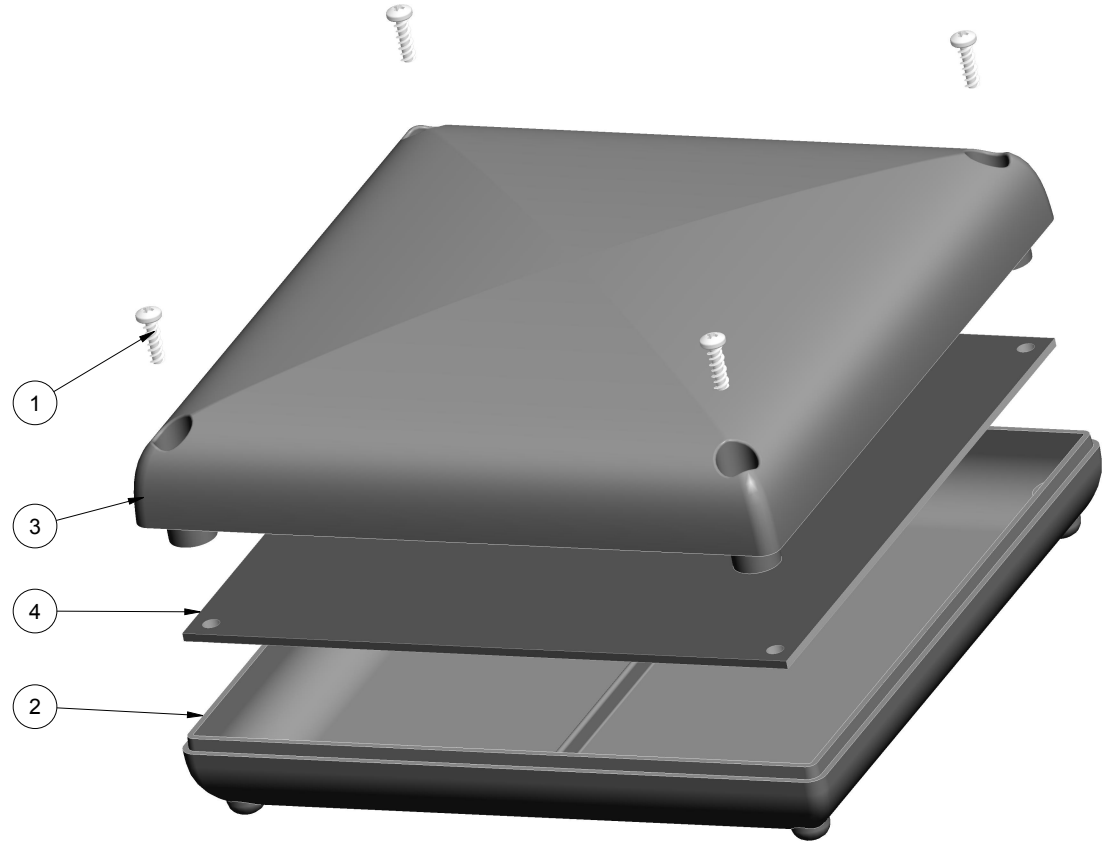

SCALE 0.750

ITEM	FILE NAME	DESCRIPTION	MATERIAL	COLOR	QTY.
4	505015_PCB	505015 PCB - REFERENCE	.062" THICK	CUSTOMER SUPPLIED	1
3	505015_COVER	505015 COVER - STANDARD	ABS	BLACK or WHITE	1
2	505015_BASE	505015 BASE - STANDARD	ABS	BLACK or WHITE	1
1	SCREW_HILO-N04X375	#4 HiLo x .375" SCREW	ZINK PLATED	.375" LONG	4

BILL OF MATERIALS

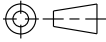
THIRD ANGLE PROJECTION  DO NOT SCALE DRAWING		TOLERANCES: UNLESS OTHERWISE SPECIFIED DIMENSIONS ARE IN U.S. INCHES. X.XX = .015 X.XXXX = .001 X.XXX = .010 X.X" = 1°		NEW AGE ENCLOSURES 4330 Santa Fe Road San Luis Obispo, CA. 93401 ph. (805) 595-1310 fax (805) 595-1024 www.newageenclosures.com	
NEW AGE ENCLOSURES Customer's Part No: 505015		APPROVAL BY DATE CHECK _____ ENG. _____ SCALE AS NOTED			
DRAWN BY M BOYER		DATE 2015-Feb-12		SIZE A	DRAWING NAME 505015_RB
SHEET 1 OF 6				REV.DOC B	

NEW AGE ENCLOSURES

TABLE TOP - STANDARD
SXX-505015-XXX

505015 ASSEMBLY

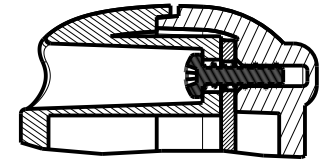
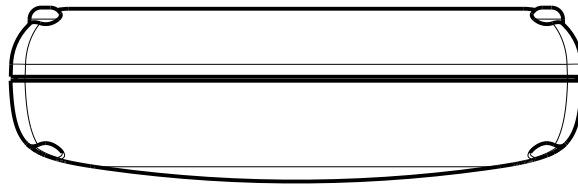

DETAIL B
SCALE 1.200

SEE DETAIL B

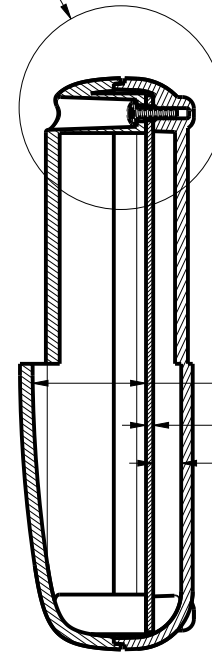
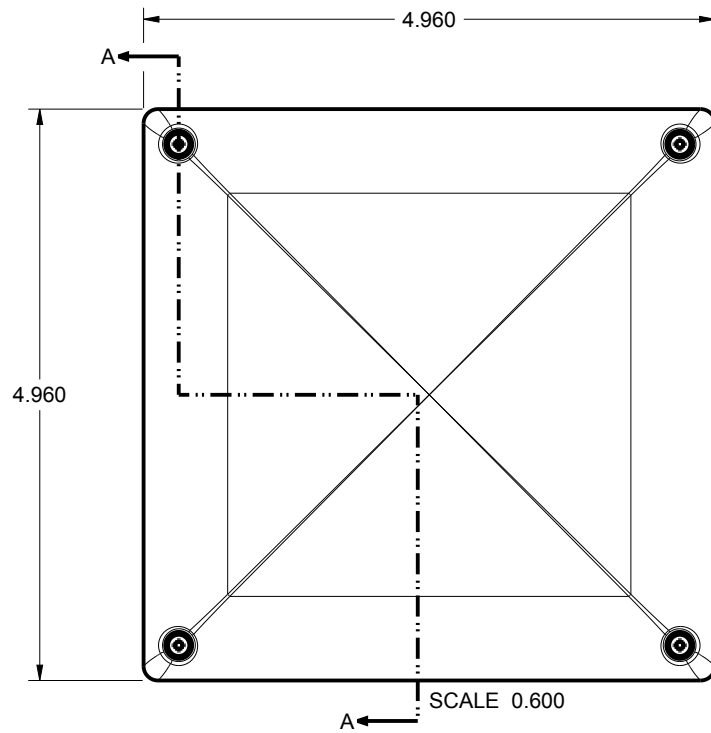

SECTION A-A

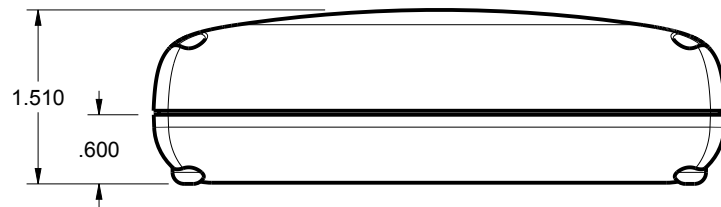
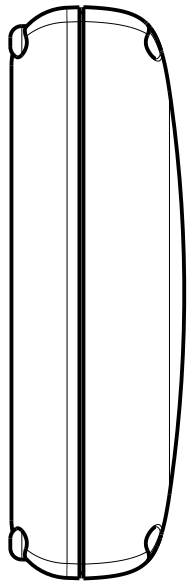
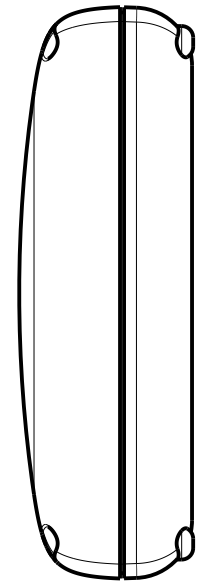

TOLERANCES: UNLESS OTHERWISE SPECIFIED
DIMENSIONS ARE IN U.S. INCHES.
X.XX = .015 X.XXXX = .001
X.XXX = .010 X.X° = 1°

NEW AGE ENCLOSURES

Customer's Part No: 505015

APPROVAL	BY	DATE
CHECK		
ENG.		
SCALE	AS NOTED	

DRAWN BY
M BOYER

2015-Feb-12

NEW AGE ENCLOSURES

4330 Santa Fe Road San Luis Obispo, CA. 93401
ph. (805) 595-1310 fax (805) 595-1024
www.newageenclosures.com

**TABLE TOP - STANDARD
SXX-505015-XXX**

SIZE A	DRAWING NAME 505015_RB	SHEET 2 OF 6	REV.DOC B
-----------	---------------------------	-----------------	--------------

505015 COVER

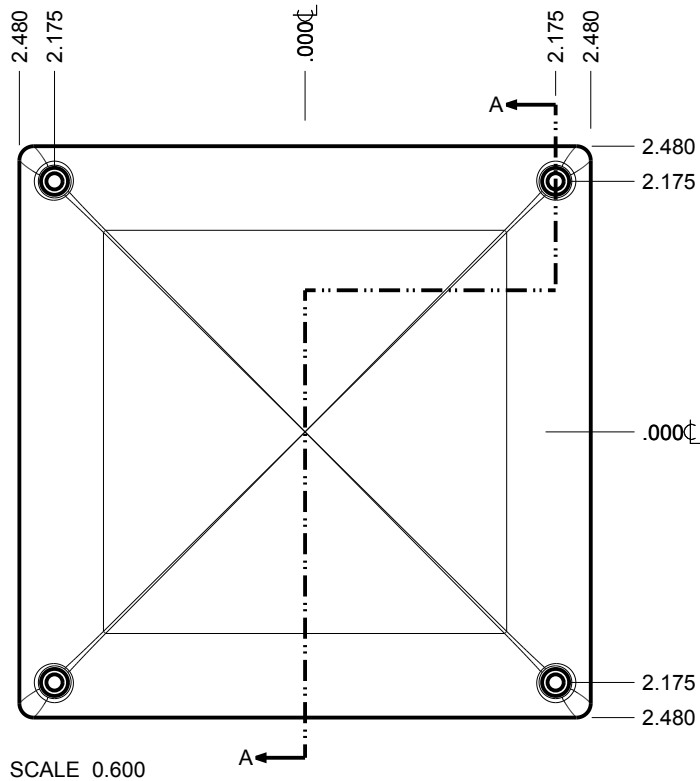

SCALE 0.600

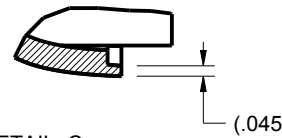
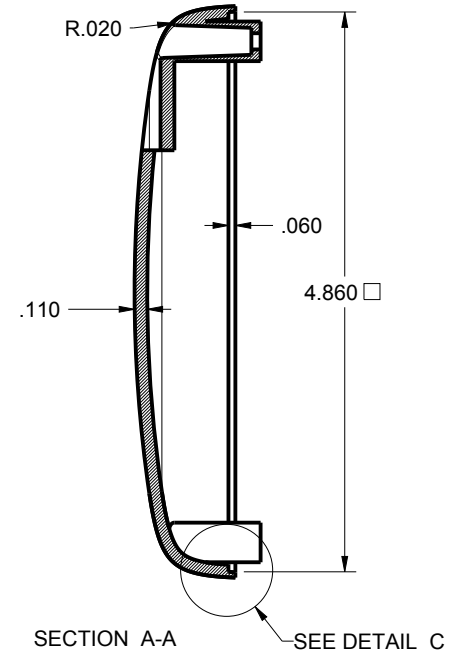

DETAIL C
SCALE 1.200

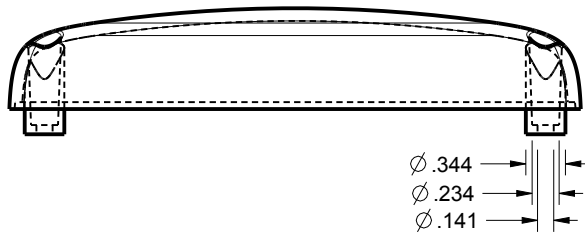

TOLERANCES: UNLESS OTHERWISE SPECIFIED DIMENSIONS ARE IN U.S. INCHES.	
X.XX = .015 X.XXXX = .001	
X.XXX = .010 X.X° = 1°	
NEW AGE ENCLOSURES	
Customer's Part No: 505015	
APPROVAL	BY DATE
CHECK	
ENG.	
SCALE	AS NOTED
DRAWN BY	2015-Feb-12
M BOYER	

NEW AGE ENCLOSURES
 4330 Santa Fe Road San Luis Obispo, CA. 93401
 ph. (805) 595-1310 fax (805) 595-1024
www.newageenclosures.com

TABLE TOP - STANDARD
SXX-505015-XXX

SIZE	DRAWING NAME	SHEET	REV.DOC
A	505015_RB	3 OF 6	B

505015 BASE

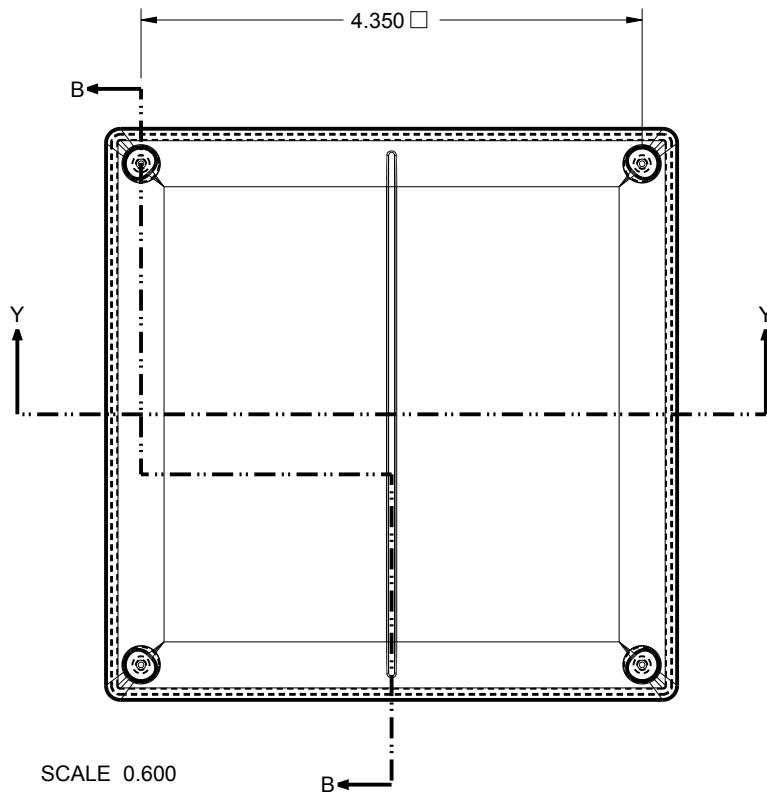

SCALE 0.600

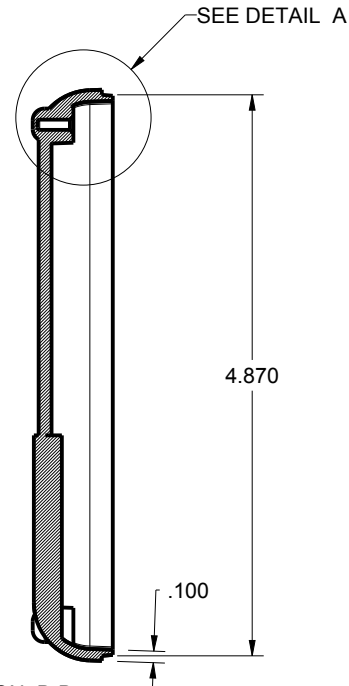
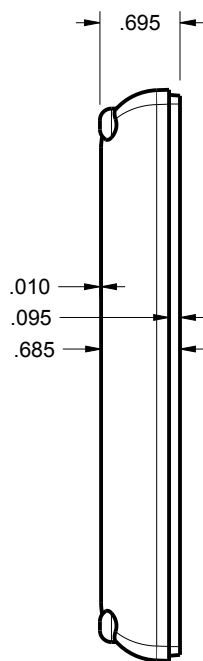

SECTION B-B

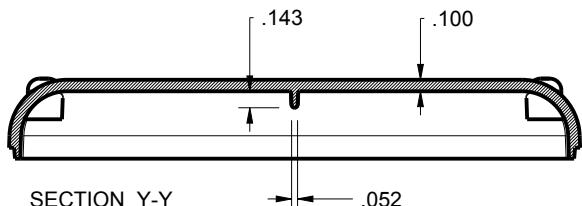
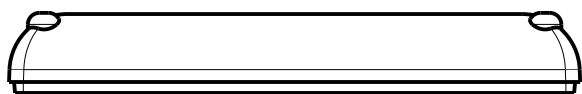

SECTION Y-Y

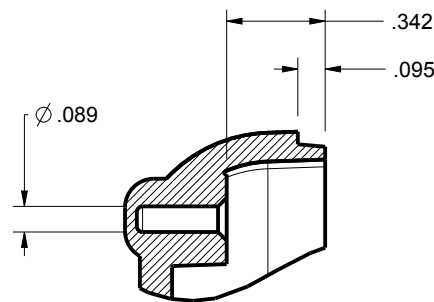

DETAIL A
SCALE 1.500

TOLERANCES: UNLESS OTHERWISE SPECIFIED
DIMENSIONS ARE IN U.S. INCHES.
X.XX = .015 X.XXXX = .001
X.XXX = .010 X.X° = 1°

NEW AGE ENCLOSURES
Customer's Part No: 505015

APPROVAL	BY	DATE
CHECK		
ENG.		
SCALE	AS NOTED	
DRAWN BY	M BOYER	
	2015-Feb-12	

NEW AGE ENCLOSURES
 4330 Santa Fe Road San Luis Obispo, CA. 93401
 ph. (805) 595-1310 fax (805) 595-1024
www.newageenclosures.com

**TABLE TOP - STANDARD
SXX-505015-XXX**

SIZE	DRAWING NAME	SHEET	REV.DOC
A	505015_RB	4 OF 6	B

505015 PCB - CUSTOMER SUPPLIED

PCB SIZES ARE RECOMMENDATIONS ONLY. FINAL SIZES AND VERIFICATION OF ITS FIT ARE THE SOLE RESPONSIBILITY OF THE OEM.

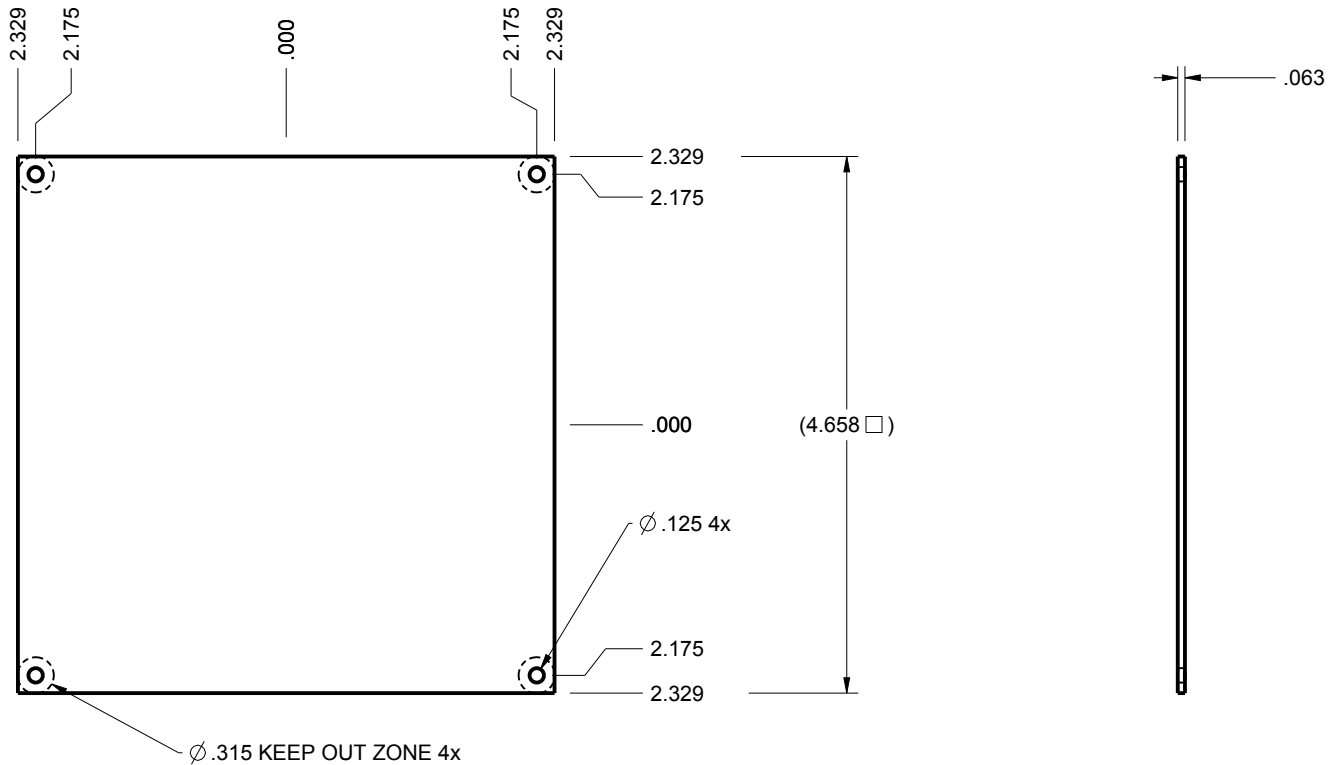

TOLERANCES: UNLESS OTHERWISE SPECIFIED DIMENSIONS ARE IN U.S. INCHES.
 X.XX = .015 X.XXXX = .001
 X.XXX = .010 X.X° = 1°

NEW AGE ENCLOSURES

Customer's Part No: 505015

APPROVAL	BY	DATE
CHECK		
ENG.		
SCALE	AS NOTED	

DRAWN BY
M BOYER 2015-Feb-12

NEW AGE ENCLOSURES

4330 Santa Fe Road San Luis Obispo, CA. 93401
 ph. (805) 595-1310 fax (805) 595-1024
www.newageenclosures.com

TABLE TOP - STANDARD
 SXX-505015-XXX

SIZE A	DRAWING NAME 505015_RB	SHEET 5 OF 6	REV.DOC B
-----------	---------------------------	-----------------	--------------

505015 - 2nd OPERATION DETAILS

NEW AGE ENCLOSURES DELIVERS YOUR ENCLOSURE MARKET-READY WITH IN-HOUSE
CNC MACHINING, PAD PRINTING, ASSEMBLY, AND FULFILLEMENT.
ALL SURFACES AND AREAS ARE AVAILABLE FOR CNC ALTERATION BY NEW AGE ENCLOSURES
CALL (805) 595-1310 FOR PRICING AND SCHEDULE.
THE INSIDE RADIUS OF ANY MACHINED FEATURES SHOULD BE NO SMALLER THAN .031"

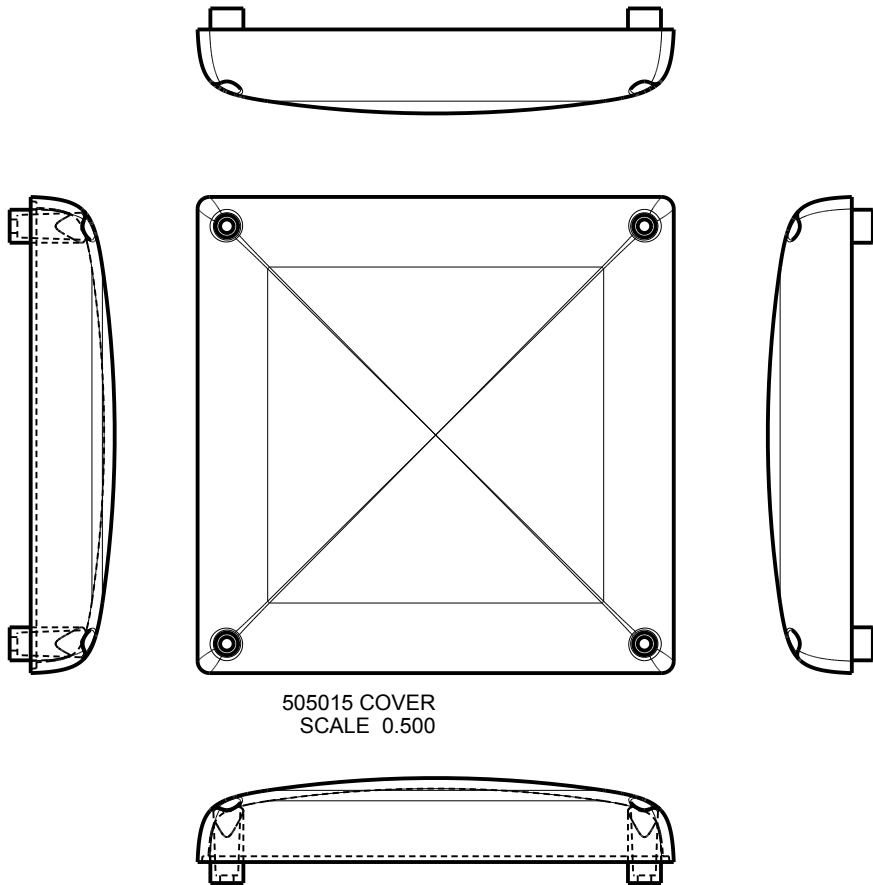

505015 COVER
SCALE 0.500

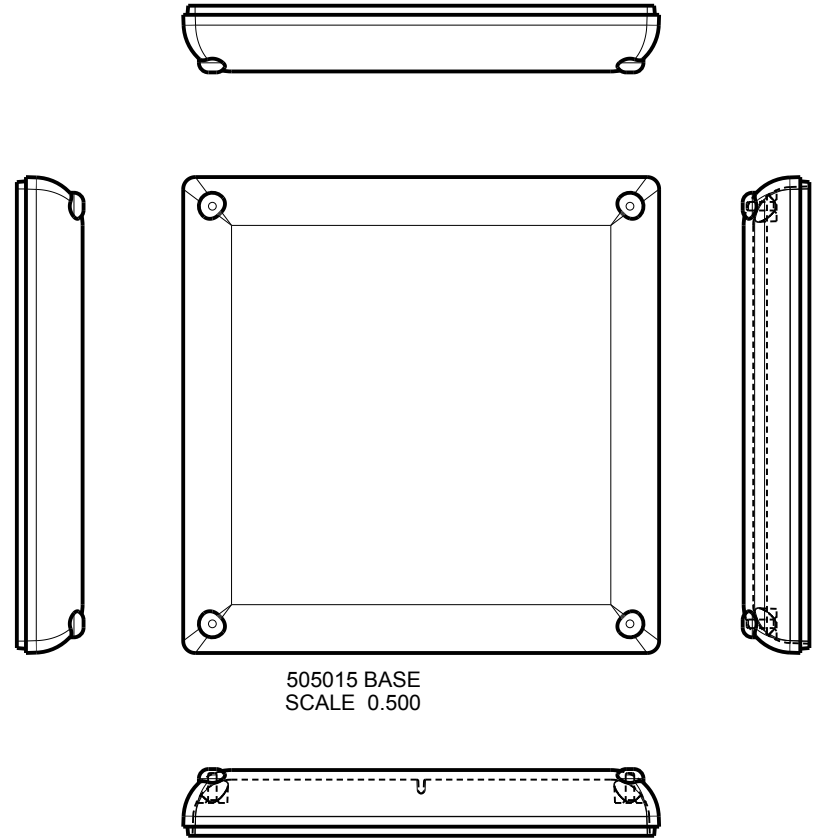

505015 BASE
SCALE 0.500

TOLERANCES: UNLESS OTHERWISE SPECIFIED
DIMENSIONS ARE IN U.S. INCHES.
X.XX = .015 X.XXXX = .001
X.XXX = .010 X.X° = 1°

NEW AGE ENCLOSURES

Customer's Part No: 505015

APPROVAL	BY	DATE
CHECK		
ENG.		
SCALE	AS NOTED	
DRAWN BY	2015-Feb-12	
M BOYER		

NEW AGE ENCLOSURES

4330 Santa Fe Road San Luis Obispo, CA. 93401
ph. (805) 595-1310 fax (805) 595-1024
www.newageenclosures.com

TABLE TOP - STANDARD
SXX-505015-XXX

SXX-505015-XXX COVER - ABS, BLACK					
STEP NO	DESCRIPTION	CUTTER	FIXTURE	ORIENTATION	PROGRAM
1-C-C1	-	T2 = .062" EM	-	-	01001
2-C-C2	-	T2 = .062" EM	-	-	01002

SIZE	DRAWING NAME	SHEET	REV.DOC
A	505015_RB	6 OF 6	B

Данный компонент на территории Российской Федерации

Вы можете приобрести в компании MosChip.

Для оперативного оформления запроса Вам необходимо перейти по данной ссылке:

<http://moschip.ru/get-element>

Вы можете разместить у нас заказ для любого Вашего проекта, будь то серийное производство или разработка единичного прибора.

В нашем ассортименте представлены ведущие мировые производители активных и пассивных электронных компонентов.

Нашей специализацией является поставка электронной компонентной базы двойного назначения, продукции таких производителей как XILINX, Intel (ex.ALTERA), Vicor, Microchip, Texas Instruments, Analog Devices, Mini-Circuits, Amphenol, Glenair.

Сотрудничество с глобальными дистрибьюторами электронных компонентов, предоставляет возможность заказывать и получать с международных складов практически любой перечень компонентов в оптимальные для Вас сроки.

На всех этапах разработки и производства наши партнеры могут получить квалифицированную поддержку опытных инженеров.

Система менеджмента качества компании отвечает требованиям в соответствии с ГОСТ Р ИСО 9001, ГОСТ РВ 0015-002 и ЭС РД 009

Офис по работе с юридическими лицами:

105318, г.Москва, ул.Щербаковская д.3, офис 1107, 1118, ДЦ «Щербаковский»

Телефон: +7 495 668-12-70 (многоканальный)

Факс: +7 495 668-12-70 (доб.304)

E-mail: info@moschip.ru

Skype отдела продаж:

moschip.ru

moschip.ru_4

moschip.ru_6

moschip.ru_9