

RAD-AI4-IFS

I/O extension module, 4 analog current inputs

INTERFACE

Data sheet
104839_en_01

© PHOENIX CONTACT 2013-01-21

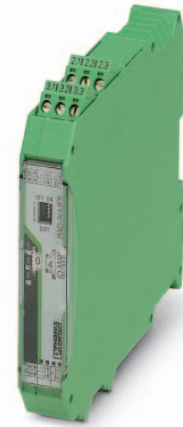

1 Description

The **RAD-AI4-IFS** I/O extension module can be used in conjunction with Radioline wireless modules and other Interface System (IFS) master devices. In a station structure, you can connect up to 32 I/O extension modules to a wireless module via the DIN rail connector.

The **RAD-AI4-IFS** analog I/O extension module is used for processing four input signals.

Features

- Easy and tool-free I/O mapping via thumb wheel on the front
- Modular design via TBUS DIN rail connector (hot-swap capable)
- Channel-to-channel electrical isolation
- 4 analog inputs (alternatively 0/4 ... 20 mA)
- 16-bit resolution of the analog inputs (accuracy < 0.02%)
- Loop-power function for passive sensors
- International approvals
- Installation in Ex-Zone 2



WARNING: Correct usage in potentially explosive areas

The module is a category 3 item of electrical equipment. Follow the instructions provided here during installation and observe the safety instructions.



Make sure you always use the latest documentation.
It can be downloaded from the product at www.phoenixcontact.net/products.



This data sheet is valid for all products listed on the following page:

2	Table of contents	
1	Description	1
2	Table of contents	2
3	Ordering data	3
4	Technical data	3
5	Safety regulations and installation notes.....	6
	5.1 Installation and operation.....	6
	5.2 Safety regulations for installation in potentially explosive areas	7
6	Installation	8
	6.1 Structure	8
	6.2 Basic circuit diagram	8
	6.3 Configuration	9
	6.4 Display and diagnostic elements	10
	6.5 Analog input	10
	6.6 Assembly/removal	11
	6.7 Connecting the cables	11
7	Process data.....	12

3 Ordering data

Description	Type	Order No.	Pcs. / Pkt.
Analog expansion module with 4 analog current inputs (0/4 mA ... 20 mA), with screw connection, incl. DIN rail connector	RAD-AI4-IFS	2901537	1
Accessories	Type	Order No.	Pcs. / Pkt.
2400 MHz wireless transceiver with RS-232, RS-485 2-wire interface, expandable with I/O extension modules, with screw connection, antenna connection: RSMA (female), including DIN rail connector	RAD-2400-IFS	2901541	1
Bidirectional, Radioline 900 MHz transceiver for wireless transmission of serial and I/O data	RAD-900-IFS	2901540	1
DIN rail connector for DIN rail power supply unit, gold-plated contacts, for DIN rail mounting, 5-pos.	ME 17,5 TBUS 1,5/ 5-ST-3,81 GN	2709561	10
Analog I/O extension module with 4 analog current/voltage outputs (0/4 mA ... 20 mA, 0...10 V), with screw connection, incl. DIN rail connector	RAD-AO4-IFS	2901538	1

4 Technical data

Dimensions (nominal sizes in mm)

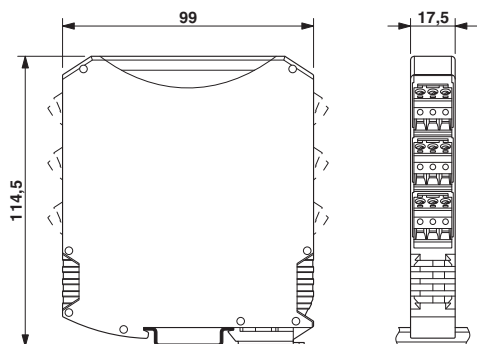

Dimensions W / H / D	17.5 mm / 99 mm / 114.5 mm
----------------------	----------------------------

General data

Surge voltage category	II
Mounting position	Any , on standard DIN rail NS 35 in accordance with EN 60715
Degree of protection	IP20
Pollution degree	2
Type of housing	PA 6.6-FR , green
Inflammability class according to UL 94	V0

Supply

Supply voltage range	19.2 V DC ... 30.5 V DC (T-connector)
Max. current consumption	max. 120 mA (At 24 V DC, at 25°C)
Transient surge protection	Yes

Analog input

Number of inputs	4
Current input signal	0 mA ... 20 mA (can be set via DIP switches) 4 mA ... 20 mA (can be set via DIP switches)
Max. current input signal	22 mA
Input resistance current input	< 70 Ω
Input frequency	Approx. 30 Hz
Precision	≤ 0.02 % (@25°C)
Temperature coefficient, typical	0.0025 %/K (At -40°C...+70°C)
Supply voltage	≥ 12 V DC (For passive sensors (via terminal PWR1, +I1))
Resolution (bit)	16 (Bit)
Protective circuit	Overload protection, short-circuit protection

Electrical isolation

Analog I/O	50 V (Rated insulation voltage (in each case between the TBUS analog outputs / supply, reinforced insulation according to EN 61010, EN 50178))
------------	--

Test voltage

Analog I/O	1.5 kV AC (50 Hz, 1 min.)
------------	---------------------------

Connection data

Connection method	Screw connection
Conductor cross section, solid	0.2 mm ² ... 2.5 mm ²
Conductor cross section, stranded	0.2 mm ² ... 2.5 mm ²
Conductor cross section AWG/kcmil	24 ... 14
Stripping length	7 mm
Tightening torque	0.6 Nm

Status indication

Status display	Green LED (supply voltage, PWR) Green LED (bus communication, DAT) Red LED (periphery error, ERR)
----------------	---

Ambient conditions

Ambient temperature (operation)	-40 °C ... 70 °C (>55°C Derating) -40 °F ... 158 °F (>131 °F derating)
Ambient temperature (storage/transport)	-40 °C ... 85 °C -40 °F ... 185 °F
Permissible humidity (operation)	20 % ... 85 %
Permissible humidity (storage/transport)	20 % ... 85 %
Altitude	2000 m
Vibration (operation)	In accordance with IEC 60068-2-6: 5 g, 10 Hz - 150 Hz
Shock	16 g, 11 ms

Operating conditions for the extended temperature range (+55°C ... 70°C)

No function restrictions for the extended temperature range if you keep a minimum distance of 17.5 mm between the modules. The minimum distance is the width of a DIN rail connector.
Otherwise please observe the following restrictions:
- Make sure that no more than 40 mA in total is drawn from the loop-powered PWR₁ ... PWR₄ outputs.
Individual operating conditions on request.

Certification

Conformance	CE-compliant
ATEX	Ⓜ II 3 G Ex nA IIC T4 Gc X
IECEX	Applied for
UL, USA / Canada	UL applied for

Conformance

EMC directive 2004/108/EC	EN 61000-6-2; EN 61000-6-4
Ex directive (ATEX)	EN 60079-0; EN 60079-15

Tolerances influenced by electromagnetic interference

Type of electromagnetic interference	Typical deviation of the measuring range final value (current input)	
	Relative	Absolute
-		
Electromagnetic fields according to EN 61000-4-3/IEC 61000-4-3	< ±0.2%	±40 µA
Conducted interference according to EN 61000-4-6/IEC 61000-4-6	< ±0.35%	±70 µA
Fast transients (burst) according to EN 61000-4-4/IEC 61000-4-4	< ±0.2%	±40 µA

5 Safety regulations and installation notes

5.1 Installation and operation

Follow the installation instructions.



NOTE: Installation, operation, and maintenance may only be carried out by qualified specialist personnel.

Error-free operation of this device can only be ensured if transport, storage, and assembly are carried out correctly and operation and maintenance are carried out with care.

When installing and operating the device, the applicable safety directives (including national safety directives), accident prevention regulations, as well as general technical regulations, must be observed.



WARNING: Risk of electric shock

During operation, certain parts of this device may carry hazardous voltages. Disregarding this warning may result in damage to equipment and/or serious personal injury.

For applications with high operating voltages, ensure sufficient distance or insulation and provide shock protection.



NOTE: Access to circuits within the device is not permitted.

Do not repair the device yourself but replace it with an equivalent device.

Repairs may only be carried out by the manufacturer. The manufacturer is not liable for damage resulting from a failure to comply.

Provide a switch/circuit breaker close to the device, which is labeled as the disconnect device for this device.

Provide overcurrent protection ($I \leq 6 \text{ A}$) in the installation.



During maintenance work, disconnect the device from all effective power sources.



NOTE: The IP20 degree of protection (IEC 60529/EN 60529) of the device is intended for a clean and dry environment. Do not subject the device to mechanical and/or thermal loads that exceed the specified limits.

For the safety data, please refer to the operating instructions and certificates (EC-type examination certificate, other approvals, if necessary).

5.2 Safety regulations for installation in potentially explosive areas

Installation in zone 2



WARNING: Explosion hazard

The device is designed for installation in zone 2 potentially explosive areas according to directive 94/9/EC. Observe the specified conditions for use in potentially explosive areas.



WARNING: Explosion hazard

Install the device into a housing (control or distributor box) that meets the requirements of EN 60079-0 and EN 60079-15 and has at least IP54 protection (EN 60529).



WARNING: Explosion hazard

When installing and connecting the supply and signal circuits observe the requirements of EN 60079-14. Only devices suitable for operation in Ex zone 2 and the conditions at the application site may be connected to the circuits in zone 2.



WARNING: Explosion hazard

In potentially explosive areas, only connect and disconnect cables when the power is disconnected.

Installation/removal of the devices on/from the TBUS DIN rail connector may only be performed when no voltage is applied.



WARNING: Explosion hazard

Only use category 3G devices (ATEX 94/9/EC).



WARNING: Explosion hazard

The device must be stopped and immediately removed from the Ex area if it is damaged or was subject to an impermissible load or stored incorrectly or if it malfunctions.

Installation in areas with a danger of dust explosions



WARNING: Explosion hazard

The device has not been designed for use in potentially dust-explosive atmospheres.

6 Installation



NOTE: electrostatic discharge!

The device contains components that can be damaged or destroyed by electrostatic discharge. When handling the device, observe the necessary safety precautions against electrostatic discharge (ESD) according to EN 61340-5-1 and EN 61340-5-1.

6.1 Structure



Bild 1 RAD-AI4-IFS

Pos.	Designation
1	Analog input 2 for 2, 3, 4-wire measuring transducer
2	Analog input 1 for 2, 3, 4-wire measuring transducer
3	DIP switches for configuring the analog inputs (current/voltage input)
4	I/O MAP address setting via thumb wheel
5	Connection option for TBUS DIN rail connector
6	DIN rail
7	Metal foot catch for DIN rail fixing
8	Analog input 3 for 2, 3, 4-wire measuring transducer
9	Analog input 4 for 2, 3, 4-wire measuring transducer
10	ERR status LED, red (communication error)
11	DAT status LED, green (BUS communication)
12	PWR status LED, green (supply voltage)

6.2 Basic circuit diagram

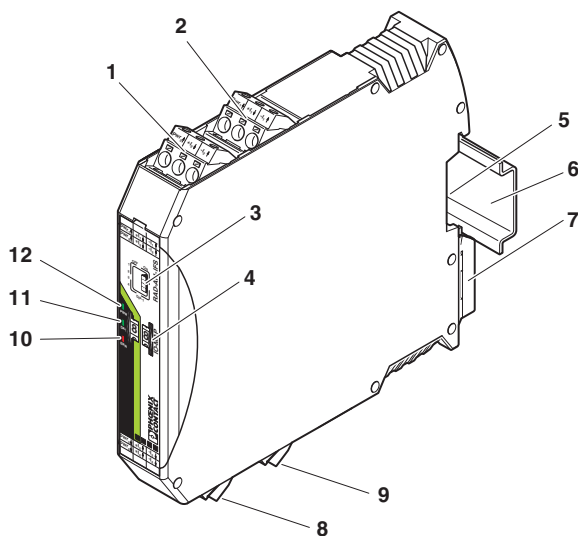

Bild 2 RAD-AI4-IFS basic circuit diagram

6.3 Configuration

The DIP switches on the front can be used to configure the input signals ranges (0 ... 20 mA or 4 ... 20 mA).

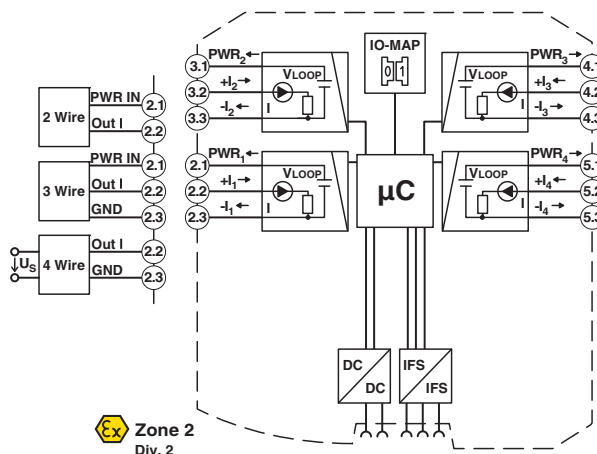

Bild 3 DIP switches

Input	Configuration	DIP switch			
		1	2	3	4
Analog IN1	0...20 mA	off			
Analog IN1	4...20 mA	on			
Analog IN2	0...20 mA		off		
Analog IN2	4...20 mA		on		
Analog IN3	0...20 mA			off	
Analog IN3	4...20 mA			on	
Analog IN4	0...20 mA				off
Analog IN4	4...20 mA				on

I/O MAP address

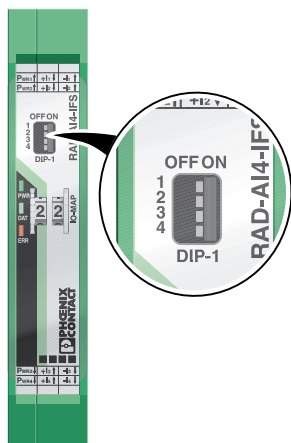

Bild 4 Thumb wheel

Use the thumb wheel to set the I/O MAP address. The address is used to address the I/O module for use in the Radioline wireless system.

The following conditions must be met:

On the entire wireless network, addresses 1 to 99 (I/O MAP) (maximum) may be assigned for the I/O extension modules.

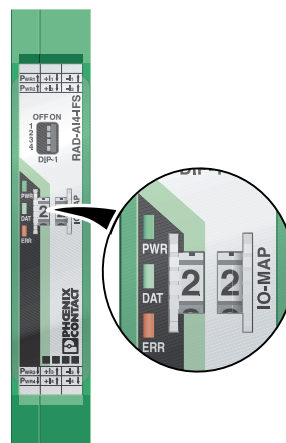
Thumb wheel settings	Description
01 - 99	I/O MAP address
00	Delivery state
** , 1* - 9*	Setting not permitted
1* - 9*	Interface System slave address, for use with Interface System (IFS) master devices

Wireless module in I/O data mode (wire in/wire out)

The input device must be provided with the same I/O MAP address as the assigned output device at the other wireless station (I/O mapping).

The I/O MAP address of an input module may only appear once in the network.

Example:	I/O MAP address
RAD-AI4-IFS	02
RAD-AO4-IFS	02

Only the RAD-AO4-IFS module can be assigned to the RAD-AI4-IFS module.

Wireless module in PLC/Modbus RTU mode

The I/O MAP address of an input module may only appear once in the network.

The input data is saved in a Modbus memory map in the master wireless module.

You can read or write the process data via the serial interface of the RAD-2400-IFS master wireless module (RAD-ID = 01) using the Modbus RTU command (see Section 7).

6.4 Display and diagnostic elements

3 LEDs on the RAD-AI4-IFS I/O extension module in total indicate the operating states.



Bild 5 Display and diagnostic elements

PWR LED

The green PWR LED indicates the supply voltage status.

Off: No supply voltage
On: Supply voltage OK

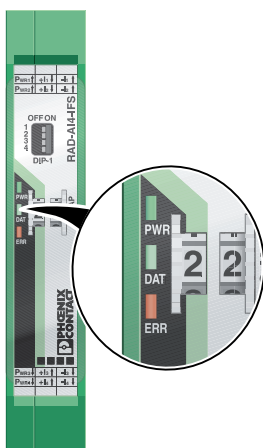
DAT LED

The green DAT LED indicates the bus communication status.

Off: No communication
Flashing: Configuration/addressing mode
On: Cyclic data communication

ERR LED

The red ERR LED indicates the error status, e.g., no corresponding output module found (e.g., incorrect addressing).

Off: No error
Flashing: Slow (1.4 Hz) I/O-MAP address changed
Fast (2.8 Hz) No bus communication
On: Critical internal error

6.5 Analog input

The analog input of the extension module is able to process standard signals (0/4...20 mA).

All the inputs are electrically isolated from one another, from the supply voltage (via bus foot), and from other electronic components.

A supply voltage of 12 V DC, minimum, is available at the connection terminal block (PWR₁) for the use of passive sensors (1 in Figure 1, connection assignment see Figure 2).

6.6 Assembly/removal



Bild 6 Mounting and removing

6.7 Connecting the cables



Bild 7 Connection of the cables

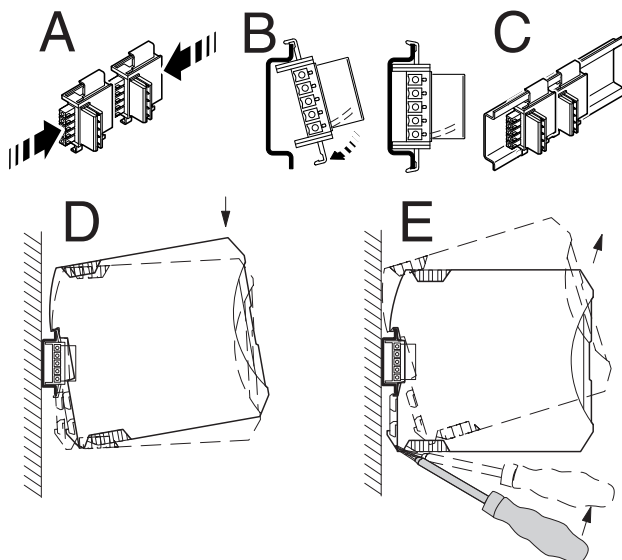

The use of the TBUS DIN rail connector for the supply of modules is only possible with 24 V DC devices.

- When using the DIN rail connector, first insert it in the 35 mm DIN rail according to EN 60715 (see Figure 6, A - C). The DIN rail connector is used to bridge the power supply and communication.

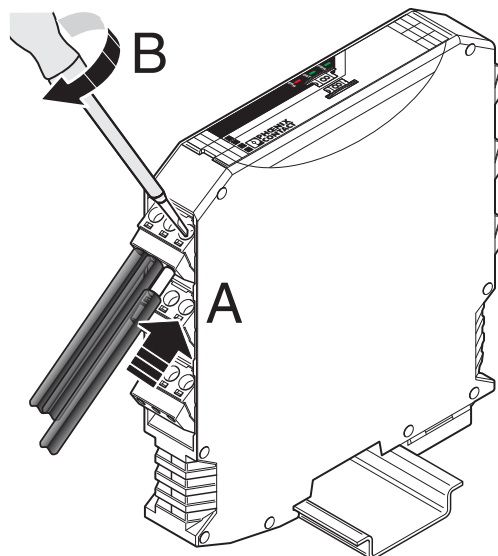

In this case, it is vital to observe the mounting direction of the module and DIN rail connector: snap-on foot at the bottom and connector on the left.

- Install the module in a suitable housing to meet the requirements for the protection class.
- Before startup, check that the RAD-AI4-IFS is operating and wired correctly, in particular with regard to the wiring and labeling.
- You can establish a connection between two DIN rail connectors using MINI COMBICON plug-in connectors: MC 1,5/5-ST-3,81 (female, 1803604); IMC 1,5/5-ST-3,81 (male, 1857919).



The maximum cable length is 10 m. Use shielded cables.

- Crimp ferrules to the wires. Permissible cable cross section: 0.2...2.5 mm².
- Insert the wire with ferrule into the corresponding connection terminal block.
- Use a screwdriver to tighten the screw in the opening above the connection terminal block. Tightening torque: 0.6 Nm

7 Process data

You can read the process data via the serial interface of the RAD-2400-IFS master wireless module (RAD-ID = 01) using the Modbus RTU command.

With the PSI-CONF software, you can set the wireless module's network application to "PLC/Modbus RTU mode".

The process image of the I/O module consists of ten data words of which six are being used.

I/O module	RAD-AI4-IFS
Module type	20 _{hex}
Number of registers	06 _{hex}
Address space	30xx0-30xx5
Modbus function code	fc04

xx = I/O-MAP address set using the thumbwheel

30xx0 Module type and currentness of data

Byte	Byte 0 (high byte)							
Bit	15	14	13	12	11	10	09	08
Module type								
Currentness of data								X
Byte	Byte 1 (low byte)							
Bit	07	06	05	04	03	02	01	00
Module type	0	0	1	0	0	0	0	0
Currentness of data								

Register values:

Module type	If the module type in the register is invalid or unavailable, then the register value is 0
Currentness of data	If the data in the register is not up-to-date, then the register value is 1. This is the case if, for example, the wireless connection fails. The IN process data is retained in the Modbus table, but is no longer updated.

The read I/O data is only valid if a valid module type value is returned by the slave and if bit 8 is not set.

30xx1 Reserved 30xx2 Analog input 1

Byte	Byte 0 (high byte)							
Bit	15	14	13	12	11	10	09	08
Channel	AI1	AI1	AI1	AI1	AI1	AI1	AI1	AI1
Terminal point								
Byte	Byte 1 (low byte)							
Bit	07	06	05	04	03	02	01	00
Channel	AI1	AI1	AI1	AI1	AI1	AI1	AI1	AI1
Terminal point								2.x

30xx3 Analog input 2

Byte	Byte 0 (high byte)							
Bit	15	14	13	12	11	10	09	08
Channel	AI2	AI2	AI2	AI2	AI2	AI2	AI2	AI2
Terminal point								
Byte	Byte 1 (low byte)							
Bit	07	06	05	04	03	02	01	00
Channel	AI2	AI2	AI2	AI2	AI2	AI2	AI2	AI2
Terminal point								3.x

30xx4 Analog input 3

Byte	Byte 0 (high byte)							
Bit	15	14	13	12	11	10	09	08
Channel	AI3	AI3	AI3	AI3	AI3	AI3	AI3	AI3
Terminal point								
Byte	Byte 1 (low byte)							
Bit	07	06	05	04	03	02	01	00
Channel	AI3	AI3	AI3	AI3	AI3	AI3	AI3	AI3
Terminal point								4.x

30xx5 Analog input 4

Byte	Byte 0 (high byte)							
Bit	15	14	13	12	11	10	09	08
Channel	AI4	AI4	AI4	AI4	AI4	AI4	AI4	AI4
Terminal point								
Byte	Byte 1 (low byte)							
Bit	07	06	05	04	03	02	01	00
Channel	AI4	AI4	AI4	AI4	AI4	AI4	AI4	AI4
Terminal point								5.x

30xx6 ... 30xx9 Reserved

Illustration of analog values			
Data word		0 ... 20 mA	4 ... 20 mA
hex	dec		
0000	0	0 mA	-
1770	6000	4 mA	4 mA
7530	30000	20 mA	20 mA
8001	Overrange (>32505)	> 21,67	> 21,67
8002	Open circuit (<4800)	-	<3,2 mA
8080	Underrange (<-15)	< 0 mA	-

Данный компонент на территории Российской Федерации

Вы можете приобрести в компании MosChip.

Для оперативного оформления запроса Вам необходимо перейти по данной ссылке:

<http://moschip.ru/get-element>

Вы можете разместить у нас заказ для любого Вашего проекта, будь то серийное производство или разработка единичного прибора.

В нашем ассортименте представлены ведущие мировые производители активных и пассивных электронных компонентов.

Нашей специализацией является поставка электронной компонентной базы двойного назначения, продукции таких производителей как XILINX, Intel (ex.ALTERA), Vicor, Microchip, Texas Instruments, Analog Devices, Mini-Circuits, Amphenol, Glenair.

Сотрудничество с глобальными дистрибьюторами электронных компонентов, предоставляет возможность заказывать и получать с международных складов практически любой перечень компонентов в оптимальные для Вас сроки.

На всех этапах разработки и производства наши партнеры могут получить квалифицированную поддержку опытных инженеров.

Система менеджмента качества компании отвечает требованиям в соответствии с ГОСТ Р ИСО 9001, ГОСТ РВ 0015-002 и ЭС РД 009

Офис по работе с юридическими лицами:

105318, г.Москва, ул.Щербаковская д.3, офис 1107, 1118, ДЦ «Щербаковский»

Телефон: +7 495 668-12-70 (многоканальный)

Факс: +7 495 668-12-70 (доб.304)

E-mail: info@moschip.ru

Skype отдела продаж:

moschip.ru

moschip.ru_4

moschip.ru_6

moschip.ru_9