

Digilent PmodDA2™ Digital To Analog Module Converter Board Reference Manual



www.digilentinc.com

Revision: September 25, 2006

215 E Main Suite D | Pullman, WA 99163
(509) 334 6306 Voice and Fax

Overview

The Digilent PmodDA2 Digital to Analog Module Converter, converts signals from digital values to analog voltages on two channels simultaneously with twelve bits of resolution. The PmodDA2 uses a 6-pin header connector and, at less than one square inch, is small enough to be located where the reconstructed signal is required.

Features include:

- two National Semiconductor DAC121S101, 12-bit D/A converters
- a 6-pin header and 6-pin connector
- two simultaneous D/A conversion channels
- very low power consumption
- small form factor (0.80" x 0.80").

Functional Description

The PmodDA2 can produce an analog output ranging from 0-3.3 volts when operated with a 3.3V power supply. It has two simultaneous D/A conversion channels, each with a 12-bit converter that can process separate digital signals.

The PmodDA2 is equipped with two DAC121S101 digital to analog converters. Sending commands via the SPI/MICROWIRE™ serial bus to the D/A converters produces outputs. The two converters are connected in parallel so that commands are sent to both converters simultaneously.

The PmodDA2 is designed to work with either Digilent programmable logic system boards or embedded control system boards. Most Digilent system boards, such as the Nexys, Basys, or Cerebot, have 6-pin



Figure 1
Digilent PmodDA2

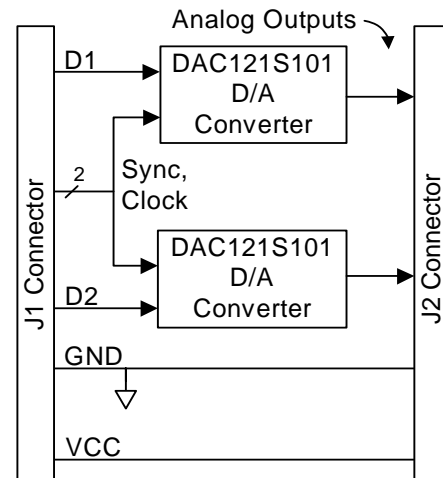

Figure 2
Block Diagram

connectors that allow the PmodDA2 to plug directly into the system board or to connect via a Digilent six-wire cable

Some older Digilent boards may need a Digilent Module Interface Board (MIB) and a 6-pin cable to connect to the PmodDA2. The MIB plugs into the system board and the cable connects the MIB to the PmodDA2.

See Table 1 for a description of the signals on the interface connectors J1 and J2. For additional information, refer to the PmodDA2 schematic available on the Digilent web site at www.digilentinc.com.

The PmodDA2 is usually powered from the Digilent system board connected to it. The power and ground connections are on pins five and six of the digital interface connector J1. Alternatively, the PmodDA2 can be powered from an external power supply provided through pins five and six of the analog interface connector J2. In this case the power select jumper on the system board should be set to disconnect power from the system board to J1. Damage may result if two power supplies are connected at the same time.

The Digilent convention is to provide 3.3V to power Pmod modules. The PmodDA2 can be operated at any power supply voltage between 2.7V and 5.5V, however caution should be exercised if using any voltage greater than 3.3V, as damage to the Digilent system board could result. For more information refer to reference manuals or schematics for the system board available at www.digilentinc.com.

For detailed information about the National Semiconductor data sheet refer to the National Semiconductor web site at www.national.com.

Table 1: Interface Connector Signal Descriptions

Digital Interface – J1	
1	SYNC (common)
2	DINA (converter IC1)
3	DINB (converter IC2)
4	SCLK (common)
5	GND
6	VCC
Analog Interface – J2	
1	VOUTA (converter IC1)
2	N/C
3	VOUTB (converter IC2)
4	N/C
5	GND
6	VCC

Данный компонент на территории Российской Федерации

Вы можете приобрести в компании MosChip.

Для оперативного оформления запроса Вам необходимо перейти по данной ссылке:

<http://moschip.ru/get-element>

Вы можете разместить у нас заказ для любого Вашего проекта, будь то серийное производство или разработка единичного прибора.

В нашем ассортименте представлены ведущие мировые производители активных и пассивных электронных компонентов.

Нашей специализацией является поставка электронной компонентной базы двойного назначения, продукции таких производителей как XILINX, Intel (ex.ALTERA), Vicor, Microchip, Texas Instruments, Analog Devices, Mini-Circuits, Amphenol, Glenair.

Сотрудничество с глобальными дистрибьюторами электронных компонентов, предоставляет возможность заказывать и получать с международных складов практически любой перечень компонентов в оптимальные для Вас сроки.

На всех этапах разработки и производства наши партнеры могут получить квалифицированную поддержку опытных инженеров.

Система менеджмента качества компании отвечает требованиям в соответствии с ГОСТ Р ИСО 9001, ГОСТ РВ 0015-002 и ЭС РД 009

Офис по работе с юридическими лицами:

105318, г.Москва, ул.Щербаковская д.3, офис 1107, 1118, ДЦ «Щербаковский»

Телефон: +7 495 668-12-70 (многоканальный)

Факс: +7 495 668-12-70 (доб.304)

E-mail: info@moschip.ru

Skype отдела продаж:

moschip.ru

moschip.ru_4

moschip.ru_6

moschip.ru_9