

Fast 100 Mbps Ethernet PICtail™ Plus Daughter Board

Overview

The Fast 100 Mbps Ethernet PICtail™ Plus Daughter Board (AC164132) is an Ethernet demonstration board for evaluating Microchip Technology's ENC424J600 and ENC624J600 stand-alone 10/100 Ethernet controllers. It is an expansion board compatible with many PICtail and PICtail Plus host boards, including the Explorer 16, PIC32 I/O Expansion Board, PICDEM.net™ 2 and PIC18 Explorer development boards.

Features

- ENC624J600 10/100 Ethernet Controller with factory preprogrammed MAC address (see “ENC424J600/624J600 Data Sheet” (DS39935) for additional information)
- 25 MHz oscillator and integrated magnetic RJ-45 connector
- PICtail Plus Daughter Board edge contacts for SPI or PSP connection to Explorer 16 and PIC32 I/O Expansion Boards
- PICtail Daughter Board headers for SPI connection to PICDEM.net 2 and PIC18 Explorer Boards
- Configuration jumpers for PSP Modes 1, 2, 3, 4, 5, 6, 9 and 10 under PMP control with automatic pinout remapping
- Current monitoring jumper
- Ethernet crossover switches
- 3.3V LDO regulator with shutdown for very low Sleep current
- 3.3V to 5V SPI level translation for the PIC18 Explorer
- SSL encryption add-on software CD for the Microchip TCP/IP Stack

Getting Started

The Fast 100 Mbps Ethernet PICtail Plus Daughter Board must be plugged into a Microchip Explorer 16, PIC32 I/O Expansion Board (with suitable PIC32 Starter Kit), PICDEM.net 2 or PIC18 Explorer development board. However, before making any connections, ensure that the JP2, “I SENSE”, jumper has a shunt installed, shorting the two pins.

The connection to the host motherboard differs based on the interface mode desired and motherboard type.

Explorer 16

For purposes of getting started, use the ENC624J600 in SPI mode. To do this, insert the Fast 100 Mbps Ethernet PICtail Plus J2 side edge contacts into the topmost position of the J5 slot on the Explorer 16. Pin 1 on J2 of the PICtail Daughter Board should align with Pin 1 on J5 of the Explorer 16. The Ethernet cable will connect to the PICtail Daughter Board on the side closest to the Explorer 16 Board's four push buttons.

PIC32 I/O Expansion Board

The PIC32 I/O Expansion Board is very similar to the Explorer 16. If using a PIC32MX360F512L based Starter Kit, insert the Fast 100 Mbps Ethernet PICtail Plus J2 side edge contacts into the topmost position of the J4 or J2 slots on the PIC32 I/O Expansion Board. Pin 1 of J2 on the PICtail Daughter Board should align with the Pin 1 slot on the PIC32 I/O Expansion Board. If using a PIC32MX460F512L based PIC32 USB Starter Board, insert the PICtail Daughter Board's J2 connector into the middle position of J4 or J2. This will result in Pin 1 of J2 on the PICtail Daughter Board aligning with Pin 33 on the PIC32 I/O Expansion Board.

PICDEM.net 2

The PICDEM.net 2 uses the PICtail Daughter Board thru-hole headers to interface using SPI mode. To make this connection, insert the Fast 100 Mbps Ethernet PICtail Plus J4 right angle header into the J5 female header on the PICDEM.net 2. Pin 1 on J4 of the PICtail Daughter Board, labeled “RE2”, must align with Pin 1 on J5 of the PICDEM.net 2 (also labeled “RE2”). This correct orientation does not connect the 2x3 J3 header to anything. The Ethernet cable will enter the PICtail Daughter Board from the same PICDEM.net 2 board edge that contains the two 10Base-T Ethernet jacks.

PIC18 Explorer

The PIC18 Explorer uses the PICtail Daughter Board thru-hole headers to interface using SPI mode, much like the PICDEM.net 2 connection. Insert the Fast 100 Mbps Ethernet PICtail Plus Daughter Board J3 and J4 right angle headers into the J9 and J3 female headers on the PIC18 Explorer, respectively. Pin 1 on J3 of the PICtail Daughter Board, labeled "ADJ", must align with Pin 1 on J9 of the PIC18 Explorer (also labeled "ADJ").

After appropriately connecting the PICtail Daughter Board to the host motherboard, apply power to the host motherboard. If an Ethernet cable is attached and a link partner is also attached at the far end of the cable, the green Ethernet link status LED will automatically turn on. The orange or amber RX/TX activity LED will also blink if Ethernet traffic is sent to the PICtail Daughter Board. If the link LED does not light as expected, it is possible that the TX and RX Ethernet data pairs are swapped. To test this, a crossover Ethernet cable could be used, or appropriate firmware may be written, to toggle the MDIX control signal which will swap the TX and RX data pairs on the PICtail Daughter Board.

Further evaluation will require the use of a TCP/IP Stack software library running on the host motherboard to appropriately control the Ethernet interface. Microchip TCP/IP Stack, Version 5.00 and later, can be used with this PICtail Daughter Board. The latest Microchip TCP/IP Stack version should be downloaded from the Microchip web site at www.microchip.com/tcpip. After obtaining and installing the stack, further getting started information is available in the TCP/IP Stack Help. Instead of building the stack, it is strongly recommended that first time testing be done using one of the stack's precompiled .hex files, if available, for the hardware and interface mode in use.

Schematic and Bill of Materials

The Fast 100 Mbps Ethernet PICtail Plus schematic and bill of materials are not provided here. They may be obtained from the Microchip web site at www.microchip.com/ethernet or by installing the latest Microchip TCP/IP Stack available from www.microchip.com/tcpip.

Jumper Configuration

The Fast 100 Mbps Ethernet PICtail Plus board has seven jumpers that control the operational mode of the ENC624J600 and enable various features. The jumper functions are summarized in the following table:

Jumper Functions

Jumper	Type	Description
JP2	Bridge	ENC624J600 Power Control and Current Sense
JP3	Bridge	ENC624J600 CLKOUT Enable to PICtail Interface
JP7	Bridge	PIC [®] MCU PMP PMA<x:8> to ENC624J600 AD<x:8> Connection Enable
JP8	Bridge	PIC MCU PMP PMA<x:8> to ENC624J600 A<x:8> Connection Enable
JP9	2-Way	ENC624J600 PSPCFG2 and Pinout Control
JP10	2-Way	ENC624J600 PSPCFG3 and Pinout Control
JP11	2-Way	ENC624J600 PSPCFG1/PSPCFG4 and Pinout Control

JP2

JP2 lies directly in series with the +3.3V power supply for the ENC624J600 and Ethernet magnetics (3V3ETH). To power the ENC624J600 from an external source, remove the JP2 shunt and connect an external power supply to the red 3V3ETH Test Point (TP2). To measure the ENC624J600 and magnetics current usage, replace the JP2 shunt with a current meter. Because the Ethernet solution will draw in excess of 200 mA when all features are enabled, apply caution before attempting to measure the current using a 200 mA fused current measurement scale, available on many handheld multimeters.

For normal device operation, JP2 must be shorted by a jumper shunt.

JP3

JP3, when shorted, will connect the ENC624J600 CLKOUT signal, after level shifting, to the PICtail connector (J4 Pin 5). If using the PIC18 Explorer, this function may be used to clock the PIC MCU via the OSC1 input. However, care must be taken to avoid violating the specifications of the Y1 crystal on the PIC18 Explorer. Ideally, the Y1 crystal should be removed, leaving the crystal soldered on will likely still work, but could force excessive current through the crystal, potentially damaging it.

Pin 5 of the PICtail Daughter Board interface is not connected on the PICDEM.net 2, so the state of JP3 will have no impact when using this host board.

If JP3 is left open, the leftmost pin (closest to the 'C' in "CLKOUT" on the board silkscreen) can be used as a convenient test point for measuring or using the ENC624J600 CLKOUT signal. Note, though, that this signal is level shifted by the U4 buffer, so the peak voltage will match the VPIC power supply (V_VAR for PIC18 Explorer, +5V for PICDEM.net 2).

The default state of JP3 is open (no jumper shunt).

JP7-JP11

JP7-JP11 control the pinout of the J1 PICtail Plus Daughter Board edge contacts required for the various Parallel Interface modes. If using the SPI interface, the states of JP7-JP11 are all unimportant. However, to avoid floating the ENC624J600 PSPCFGx input pins, it is recommended that the JP9-JP11 jumpers have a shunt installed at all times in either the 3V3 or GND configuration.

If using a Parallel Interface mode, set the jumpers according to the desired mode.

Parallel Interface Mode Jumper Settings

PSP Mode	PMA to AD	PMA to A	PSPCFG1&4	PSPCFG2	PSPCFG3
1 (8-bit)	—	Short	GND	GND	GND
2 (8-bit) ⁽¹⁾	—	Short	3V3	GND	GND
3 (16-bit)	—	Short	GND	3V3	GND
4 (16-bit) ⁽¹⁾	—	Short	3V3	3V3	GND
5 (8-bit MUX)	Short	—	GND	GND	3V3
6 (8-bit MUX) ⁽¹⁾	Short	—	3V3	GND	3V3
9 (16-bit MUX)	—	—	GND	3V3	3V3
10 (16-bit MUX) ⁽¹⁾	—	—	3V3	3V3	3V3

Legend: — = open; Short = shunt installed; GND = middle and GND peg shorted; 3V3 = middle and 3V3 peg shorted

Note 1: Do not use PSP Modes 2, 4, 6 or 10 with the Explorer 16. Bus contention with the Explorer 16 LCD will occur.

For convenient access, this table is also printed on the backside of the Fast 100 Mbps Ethernet PICtail Plus.

The prior table assumes that Direct Addressing mode is used (all address lines are connected). For Indirect Addressing modes, with a minimal number of address lines connected, leave the JP7 (PMA to AD) and JP8 (PMA to A) jumpers open.

Since the pinout changes with the different jumper settings, refer to the **"Signal Interface"** section for the associated connections that are required.

Signal Interface

The pinout of the Fast 100 Mbps Ethernet PICtail Plus depends upon the jumper settings and which physical connector is used.

PICtail Daughter Board Dual Row Right Angle Header (J3, J4, J5)

The J3 and J4 headers are designed to provide an SPI interface to the PIC18 Explorer and PICDEM.net 2 Development Boards. The J5 connector is not used; holes for J5 are present only to aid physical alignment. The PICtail Daughter Board is not wired to permit the ENC624J600 to interface to the PIC18 Explorer or PICDEM.net 2 using any Parallel modes.

When using the PICtail Daughter Board header, the pinout is as shown in the following table:

Pinout for the PICtail™ Daughter Board Header

J3 Pin	J4 Pin	Signal Name on Board			Function
		PICtail™ Daughter Board	PIC18 Explorer	PICDEM.net™ 2	
—	4	5VEXT	+5V	—	5V Power
—	5	GND	GND	—	Ground Reference
5	—	OSC1_PIC	OSC1	—	CLKOUT to PIC® MCU (optional) ⁽¹⁾
8	—	SI/RD/RW	RC5/SDO1		SPI Data from PIC MCU
10	—	SO_VPIC	RC4/SDI1		SPI Data to PIC MCU
12	—	SCK/AL	RC3/SCK1		SPI Clock from PIC MCU
17	—	SHDN	RB5		Shutdown from PIC MCU
19	—	MDIX	RB4		Ethernet Crossover from PIC MCU
21	—	CS/CS	RB3		SPI Chip Select from PIC MCU
23	—	INT_VPIC	RB2/INT2		Interrupt to PIC MCU
26	—	VPIC	V_VAR	+5V	5V Power
28	—	GND	GND		Ground Reference

Note 1: To enable CLKOUT, JP3 must be shorted.

If using the PIC18 Explorer with a PIM installed, be sure to check the PIM schematics for any renamed or remapped pins.

PICtail Plus (SPI, J2)

The J2 board edge contacts are designed to provide an SPI interface to the Explorer 16 and PIC32 I/O Expansion Boards. The J2 board edge is keyed such that there are only three possible ways to insert it into the Explorer 16 and PIC32 I/O expansion slot:

1. Pin 1 on J2 aligns with Pin 1 on host motherboard – use SPI1 pinout.
2. Pin 1 on J2 aligns with Pin 33 on host motherboard – use SPI2 pinout.
3. Pin 1 on J2 aligns with Pin 94 on host motherboard – illegal, do not connect.

SPI1

If the PICtail Daughter Board is mated to the topmost SPI1 slot on the Explorer 16 or PIC32 I/O Expansion Board, the following connections will be made:

SPI1 Mating Connections

J2 Pin	Mating Pin	Signal Name on Board		Function
		PICtail™ Daughter Board	Explorer 16 and PIC32 I/O Exp.	
3	3	SCK/AL	RF6/SCK1	SPI Clock from PIC® MCU
5	5	SO/WR/WRL/EN	RF7/SDI1_E	SPI Data to PIC MCU
7	7	SI/RD/RW	RF8/SDO1_E	SPI Data from PIC MCU
9, 10	9, 10	GND	GND	Ground Reference
13	13	MDIX	RB3/AN3	Ethernet Crossover from PIC MCU
15, 16	15, 16	GND	GND	Ground Reference
17	17	INT/SPISEL	RE9/INT2	Interrupt to PIC MCU
19	19	CS/CS	RD14/U1CTS_E	SPI Chip Select from PIC MCU
20	20	SHDN	RD15/U1RTS_E	Shutdown from PIC MCU
23, 24	23, 24	+5V	+5V	5V Power

If using the PIC32 I/O Expansion Board with a PIC32 USB Starter Board (Rev B), do not plug the PICtail Daughter Board into the SPI1 slot. The RD14/U1CTS signal is routed on the starter board to USB power control circuitry and will cause bus contention with the ENC624J600 chip select signal.

SPI2

If the PICtail Daughter Board is mated to the middle SPI2 slot on the Explorer 16 or PIC32 I/O Expansion Board, the following connections will be made:

SPI2 Mating Connections

J2 Pin	Mating Pin	Signal Name on Board		Function
		PICtail™ Daughter Board	Explorer 16 and PIC32 I/O Exp.	
3	35	SCK/AL	RG6/PMPA2/SCK2	SPI Clock from PIC® MCU
5	37	SOWR/WRL/EN	RG7/PMPA4/SDI2	SPI Data to PIC MCU
7	39	SI/RD/RW	RG8/PMPA3/SDO2	SPI Data from PIC MCU
9, 10	41, 42	GND	GND	Ground Reference
13	45	MDIX	RA9/PMPA7	Ethernet Crossover from PIC MCU
15, 16	47, 48	GND	GND	Ground Reference
17	49	INT/SPISEL	RA15/INT4	Interrupt to PIC MCU
19	51	CS/CS	RF12/U2CTS	SPI Chip Select from PIC MCU
20	52	SHDN	RF13/U2RTS	Shutdown from PIC MCU
23, 24	55, 56	+5V	+5V	5V Power

Note that Explorer 16 and PIC32 I/O Exp. signal names are with respect to the Explorer 16 schematic, which assumes the use of a PIC24FJ128GA010 PIM. Various other PIMs (e.g., PIC32MX460F512L) have a different pinout, making several of the pin names listed in the prior two tables inaccurate. Always check the PIM or PIC32 processor board schematics, or documentation to ensure that the signals have not been rewired.

PICtail Plus (Parallel, J1)

The J1 board edge contacts are available for evaluating the ENC624J600 device's Parallel Interface modes. Due to the large number of pins required to support a parallel interface, only the Explorer 16 and PIC32 I/O Expansion Boards are set up to use this feature. The pinout of the J1 connector is set up to be driven by the host microcontroller via the Parallel Master Port (PMP) peripheral available on select processors. In some cases, where the PMP peripheral or necessary mode is unavailable, it is possible to bit-bang the parallel interface at reduced performance. However, in other cases where not all of the necessary pins are connected, it is infeasible to use the J1 parallel interface and use of the J2 SPI connector is required instead.

Even when a host processor has all of the necessary pins, there are various limitations due to pin multiplexing performed on the host motherboard. At the time of the Fast 100 Mbps Ethernet PICtail Plus product development, there are several known issues:

- On the Explorer 16, it is not possible to use the LCD module with the ENC624J600 in Parallel mode. The LCD interfaces to the same PMP lines as required for the ENC624J600; however, unlike the ENC624J600, the LCD does not include a chip select line. Therefore, it remains listening on the parallel bus at all times and all communications to/from the ENC624J600 also get processed by the LCD controller.
- On the Explorer 16, PSP Modes 2, 4, 6 and 10 must not be used. For these interface modes, any read operation from the ENC624J600 will simultaneously cause a read from the LCD, causing bus contention. To avoid this, the RD5/PMPRD signal on the Explorer 16 must be disconnected from the LCD. The LCD R/W input should then be tied to VSS to force it into Write mode at all times.
- On the Explorer 16, PSP Modes 3 and 4 should not be used. For these 16-Bit Demultiplexed modes, the Explorer 16 board's U5 25LC256 EEPROM may become selected and cause bus contention or EEPROM data corruption while communicating with the ENC624J600. The EEPROM must be removed from the board to avoid this potential problem.
- On the Explorer 16, the RF4/PMPA9/U2RX and RF5/PMPA8/U2TX pins have UART2 peripheral features multiplexed onto the same pins, as required for the PMP Address 9 and 8 control lines. Therefore, in PSP Modes 1-6, with full direct addressing capability, the Explorer 16 board's RS-232 COM port (P1) cannot be used. However, with indirect addressing, the UART is still available.
- On the Explorer 16, the D8 LED cannot be used. The RA5/TDO control signal connected to D8 is used as the chip select control signal to the ENC624J600.
- On the Explorer 16, when using PSP Modes 3, 4, 9 or 10 (all 16-bit modes), the S4, S3 and S6 push buttons cannot be used while communicating with the ENC624J600. The I/O pins used for these buttons are required for PMD13, PMD14 and PMD15, respectively.
- On the PIC32 Starter Kit (Rev C) and PIC32 USB Starter Board (Rev B) for the PIC32 I/O Expansion Board, the S1, S2 and S3 push buttons short the PMPD14, PMPD15 and PMPD13 signals to GND. As a result, when the processor is communicating to the ENC624J600 using PSP Modes 3, 4, 9 or 10 (all 16-bit modes), these push buttons cannot be used. Also, since the buttons short the pins directly to GND without current limiting resistors, users must not push any of the buttons during communications as this will cause bus contention and corrupt communications with the ENC624J600.

Other compatibility restrictions may exist and may be created in the future for new PIMs and PIC32 starter boards. Be sure to check the appropriate schematics of all involved components to ensure compatibility.

All PSP Modes

The J1 parallel interface connector has several fixed power and control signals that apply to all PSP modes and do not change, regardless of the jumper settings. These common signals are shown below:

Common Signal Connections for All PSP Modes

J1 Pin	Signal Name on Board		Function
	PICtail™ Daughter Board	Explorer 16 and PIC32 I/O Exp.	
13	MDIX	RB3/AN3	Ethernet Crossover from PIC® MCU
17	$\overline{\text{INT}}/\text{SPISEL}$	RE/INT2	Interrupt to PIC MCU
23, 24	+5V	+5V	5V Power
41	GND	GND	Ground Reference
42	PSPSEL_VSS	GND	SPISEL Pull-Down for PSP
47, 48	GND	GND	Ground Reference
55, 56	+5V	+5V	5V Power
72	CS	RA5/TDO	Chip Select from PIC MCU
85	$\overline{\text{SHDN}}$	RC1	Shutdown from PIC MCU
119, 120	GND	GND	Ground Reference

PSP Modes 1 and 2

For PSP Mode 1 (PSPCFG1/4 = PSPCFG2 = PSPCFG3 = GND) and PSP Mode 2 (PSPCFG1/4 = V_{DD}, PSPCFG2 = PSPCFG3 = GND) with direct addressing (PMA to A shorted), the ENC624J600 PSP interface signals are connected as follows:

Interface Signal Connections for PSP Modes 1 and 2 (Direct Addressing)

J1 Pin	Signal Name		Function
	ENC624J600	Explorer 16 and PIC32 I/O Exp.	
33	A2	RG9/PMPA2/SS2	Address<2> from PIC [®] MCU
34	A9	RF4/PMA9/U2RX	Address<9> from PIC MCU
35	A5	RG6/PMPA5/SCK2	Address<5> from PIC MCU
36	A8	RF5/PMA8/U2TX	Address<8> from PIC MCU
37	A4	RG7/PMPA4/SDI2	Address<4> from PIC MCU
39	A3	RG8/PMPA3/SDO2	Address<3> from PIC MCU
45	A7	RA9/PMPA7	Address<7> from PIC MCU
46	A6	RA10/PMPA6	Address<6> from PIC MCU
79	A13	RB10/PMA13	Address<13> from PIC MCU
80	A12	RB11/PMA12	Address<12> from PIC MCU
81	A11	RB12/PMA11	Address<11> from PIC MCU
82	A10	RB13/PMA10	Address<10> from PIC MCU
83	A1	RB14/PMPA1	Address<1> from PIC MCU
84	A0	RB15/PMPA0	Address<0> from PIC MCU
97	WR ⁽¹⁾ or EN ⁽²⁾	RD4/PMPWR	Write ⁽¹⁾ or Enable ⁽²⁾ Strobe from PIC MCU
98	RD ⁽¹⁾ or R/ \overline{W} ⁽²⁾	RD5/PMPRD	Read Strobe ⁽¹⁾ or Read/ \overline{Write} ⁽²⁾ Select from PIC MCU
104	AD14	RD11/PMPCS1	Address<14> from PIC MCU
109-116	AD0-AD7	RE0/PMPD0-RE7/PMPD7	Bidirectional Data<0:7>

Note 1: PSP Mode 1.

2: PSP Mode 2.

When jumpered for indirect addressing (PMA to A is open), the ENC624J600 PSP connections simplify to the following:

Interface Signal Connections for PSP Modes 1 and 2 (Indirect Addressing)

J1 Pin	Signal Name		Function
	ENC624J600	Explorer 16 and PIC32 I/O Exp.	
33	A2	RG9/PMPA2/SS2	Address<2> from PIC [®] MCU
35	A5	RG6/PMPA5/SCK2	Address<5> from PIC MCU
37	A4	RG7/PMPA4/SDI2	Address<4> from PIC MCU
39	A3	RG8/PMPA3/SDO2	Address<3> from PIC MCU
45	A7	RA9/PMPA7	Address<7> from PIC MCU
46	A6	RA10/PMPA6	Address<6> from PIC MCU
83	A1	RB14/PMPA1	Address<1> from PIC MCU
84	A0	RB15/PMPA0	Address<0> from PIC MCU
97	WR ⁽¹⁾ or EN ⁽²⁾	RD4/PMPWR	Write ⁽¹⁾ or Enable ⁽²⁾ Strobe from PIC MCU
98	RD ⁽¹⁾ or R \overline{W} ⁽²⁾	RD5/PMPRD	Read Strobe ⁽¹⁾ or Read/ $\overline{\text{Write}}$ ⁽²⁾ Select from PIC MCU
104	A8	RD11/PMPCS1	Address<8> from PIC MCU
109-116	AD0-AD7	RE0/PMPD0-RE7/PMPD7	Bidirectional Data<0:7>

- Note 1:** PSP Mode 1.
2: PSP Mode 2.

Note that for the indirect PSP Modes 1 and 2, the ENC624J600 A8 address line is connected to RD11/PMPCS1 (PMP address line A14). This necessitates slightly unusual usage of the PMP module with address translation required in the application firmware. However, this translation can be performed at compile time, resulting in no run-time performance degradation. By not using the RF5/PMA8/U2TX pin for this address bit, the PIC MCU's UART2 module can still be used.

When indirect addressing is selected, the unconnected ENC624J600 A9-A14 address lines are automatically pulled high by pull-up resistors on the PICtail Daughter Board. A fixed application could tie these pins directly to VDD without the use of resistors.

PSP Modes 3 and 4

For PSP Mode 3 (PSPCFG2 = VDD, PSPCFG1/4 = PSPCFG3 = GND) and PSP Mode 4 (PSPCFG1/4 = PSPCFG2 = VDD, PSPCFG3 = GND) with direct addressing (PMA to A shorted), the ENC624J600 PSP interface signals are connected as follows:

Interface Signal Connections for PSP Modes 3 and 4 (Direct Addressing)

J1 Pin	Signal Name		Function
	ENC624J600	Explorer 16 and PIC32 I/O Exp.	
27	AD8	RG0 (PMPD8)	Bidirectional Data<8>
28	AD11	RF0 (PMPD11)	Bidirectional Data<11>
29	AD9	RG1 (PMPD9)	Bidirectional Data<9>
30	AD10	RF1 (PMPD10)	Bidirectional Data<10>
33	A2	RG9/PMPA2/SS2	Address<2> from PIC® MCU
34	A9	RF4/PMA9/U2RX	Address<9> from PIC MCU
35	A5	RG6/PMPA5/SCK2	Address<5> from PIC MCU
36	A8	RF5/PMA8/U2TX	Address<8> from PIC MCU
37	A4	RG7/PMPA4/SDI2	Address<4> from PIC MCU
39	A3	RG8/PMPA3/SDO2	Address<3> from PIC MCU
45	A7	RA9/PMPA7	Address<7> from PIC MCU
46	A6	RA10/PMPA6	Address<6> from PIC MCU
79	A13	RB10/PMA13	Address<13> from PIC MCU
80	A12	RB11/PMA12	Address<12> from PIC MCU
81	A11	RB12/PMA11	Address<11> from PIC MCU
82	A10	RB13/PMA10	Address<10> from PIC MCU
83	A1	RB14/PMPA1	Address<1> from PIC MCU
84	A0	RB15/PMPA0	Address<0> from PIC MCU
97	WRL & WRH ⁽¹⁾ or B0SEL & B1SEL ⁽²⁾	RD4/PMPWR	16-Bit Write ⁽¹⁾ or Both Byte Select ⁽²⁾ Strokes from PIC MCU
98	RD ⁽¹⁾ or R/W ⁽²⁾	RD5/PMPRD	16-Bit Read Strobe ⁽¹⁾ or Read/Write ⁽²⁾ Select from PIC MCU
99	AD14	RD6 (PMPD14)	Bidirectional Data<14>
100	AD15	RD7 (PMPD15)	Bidirectional Data<15>
105	AD12	RD12 (PMPD12)	Bidirectional Data<12>
106	AD13	RD13 (PMPD13)	Bidirectional Data<13>
109-116	AD0-AD7	RE0/PMPD0-RE7/PMPD7	Bidirectional Data<0:7>

Note 1: PSP Mode 3.

2: PSP Mode 4.

The PICtail Daughter Board has the WRL/B0SEL signal connected to WRH/B1SEL, so only 16-bit word writes are possible. Writes to the high or low byte, individually, cannot be performed.

When jumpered for indirect addressing (PMA to A is open), the ENC624J600 PSP connections simplify to the following:

Interface Signal Connections for PSP Modes 3 and 4 (Indirect Addressing)

J1 Pin	Signal Name		Function
	ENC624J600	Explorer 16 and PIC32 I/O Exp.	
27	AD8	RG0 (PMPD8)	Bidirectional Data<8>
28	AD11	RF0 (PMPD11)	Bidirectional Data<11>
29	AD9	RG1 (PMPD9)	Bidirectional Data<9>
30	AD10	RF1 (PMPD10)	Bidirectional Data<10>
33	A2	RG9/PMPA2/SS2	Address<2> from PIC [®] MCU
35	A5	RG6/PMPA5/SCK2	Address<5> from PIC MCU
37	A4	RG7/PMPA4/SDI2	Address<4> from PIC MCU
39	A3	RG8/PMPA3/SDO2	Address<3> from PIC MCU
45	A7	RA9/PMPA7	Address<7> from PIC MCU
46	A6	RA10/PMPA6	Address<6> from PIC MCU
83	A1	RB14/PMPA1	Address<1> from PIC MCU
84	A0	RB15/PMPA0	Address<0> from PIC MCU
97	WRL & WRH ⁽¹⁾ or B0SEL & B1SEL ⁽²⁾	RD4/PMPWR	16-Bit Write ⁽¹⁾ or Both Byte Select ⁽²⁾ Strokes from PIC MCU
98	RD ⁽¹⁾ or R/W ⁽²⁾	RD5/PMPRD	16-Bit Read Strobe ⁽¹⁾ or Read/Write ⁽²⁾ Select from PIC MCU
99	AD14	RD6 (PMPD14)	Bidirectional Data<14>
100	AD15	RD7 (PMPD15)	Bidirectional Data<15>
105	AD12	RD12 (PMPD12)	Bidirectional Data<12>
106	AD13	RD13 (PMPD13)	Bidirectional Data<13>
109-116	AD0-AD7	RE0/PMPD0-RE7/PMPD7	Bidirectional Data<0:7>

Note 1: PSP Mode 3.

2: PSP Mode 4.

PSP Modes 5 and 6

For PSP Mode 5 (PSPCFG1/4 = PSPCFG2 = GND, PSPCFG3 = VDD) and PSP Mode 6 (PSPCFG1/4 = PSPCFG3 = VDD, PSPCFG2 = GND) with direct addressing (PMA to AD shorted), the ENC624J600 PSP interface signals are connected as follows:

Interface Signal Connections for PSP Modes 5 and 6 (Direct Addressing)

J1 Pin	Signal Name		Function
	ENC624J600	Explorer 16 and PIC32 I/O Exp.	
34	AD9	RF4/PMA9/U2RX	Address<9> from PIC [®] MCU
36	AD8	RF5/PMA8/U2TX	Address<8> from PIC MCU
79	AD13	RB10/PMA13	Address<13> from PIC MCU
80	AD12	RB11/PMA12	Address<12> from PIC MCU
81	AD11	RB12/PMA11	Address<11> from PIC MCU
82	AD10	RB13/PMA10	Address<10> from PIC MCU
84	AL	RB15/PMPA0	Address Latch from PIC MCU
97	WR ⁽¹⁾ or EN ⁽²⁾	RD4/PMPWR	Write ⁽¹⁾ or Enable ⁽²⁾ Strobe from PIC MCU
98	RD ⁽¹⁾ or R \overline{W} ⁽²⁾	RD5/PMPRD	Read Strobe ⁽¹⁾ or Read/ \overline{Write} ⁽²⁾ Select from PIC MCU
104	AD14	RD11/PMPCS1	Address<14> from PIC MCU
109-116	AD0-AD7	RE0/PMPD0-RE7/PMPD7	Address<0:7> from PIC MCU and Bidirectional Data<0:7>

Note 1: PSP Mode 5.

2: PSP Mode 6.

When jumpered for indirect addressing (PMA to AD is open), the ENC624J600 PSP connections simplify to the following:

Interface Signal Connections for PSP Modes 5 and 6 (Indirect Addressing)

J1 Pin	Signal Name		Function
	ENC624J600	Explorer 16 and PIC32 I/O Exp.	
84	AL	RB15/PMPA0	Address Latch from PIC® MCU
97	WR ⁽¹⁾ or EN ⁽²⁾	RD4/PMPWR	Write ⁽¹⁾ or Enable ⁽²⁾ Strobe from PIC MCU
98	RD ⁽¹⁾ or R \bar{W} ⁽²⁾	RD5/PMPRD	Read Strobe ⁽¹⁾ or Read/Write ⁽²⁾ Select from PIC MCU
104	AD8	RD11/PMPCS1	Address<8> from PIC MCU
109-116	AD0-AD7	RE0/PMPD0-RE7/PMPD7	Address<0:7> from PIC MCU and Bidirectional Data<0:7>

Note 1: PSP Mode 5.

2: PSP Mode 6.

Like indirect PSP Modes 1 and 2, the indirect PSP Modes 5 and 6 have the ENC624J600 Address Line 8 connected to RD11/PMPCS1 instead of RF5/PMA8/U2TX to allow the UART2 module to be used concurrently.

Of all possible parallel combinations, PSP Modes 5 and 6, with indirect addressing, use the least I/O pins, but still provide very respectable performance. With minimal I/O pins used, it is the least likely combination to have multiplexed board and processor features causing unexpected behavior. It, therefore, should be the starting point when evaluating the ENC624J600 device's parallel interface for the first time. When using PSP Modes 5 and 6, the ENC624J600 behavior is representative of the lower pin count ENC424J600, which only supports SPI and PSP Modes 5 and 6.

PSP Modes 9 and 10

For PSP Mode 9 (PSPCFG1/4 = GND, PSPCFG2 = PSPCFG3 = VDD) and PSP Mode 10 (PSPCFG1&4 = PSPCFG2 = PSPCFG3 = VDD), the ENC624J600 PSP interface signals are connected as follows:

Interface Signal Connections for PSP Modes 9 and 10

J1 Pin	Signal Name		Function
	ENC624J600	Explorer 16 and PIC32 I/O Exp.	
27	AD8	RG0 (PMPD8)	Address<8> from PIC MCU and Bidirectional Data<8>
28	AD11	RF0 (PMPD11)	Address<11> from PIC MCU and Bidirectional Data<11>
29	AD9	RG1 (PMPD9)	Address<9> from PIC MCU and Bidirectional Data<9>
30	AD10	RF1 (PMPD10)	Address<10> from PIC MCU and Bidirectional Data<10>
84	AL	RB15/PMPA0	Address Latch from PIC MCU
97	WRL & WRH ⁽¹⁾ or B0SEL & B1SEL ⁽²⁾	RD4/PMPWR	16-Bit Write ⁽¹⁾ or Both Byte Select ⁽²⁾ Strokes from PIC MCU
98	RD ⁽¹⁾ or R/W ⁽²⁾	RD5/PMPRD	16-Bit Read Strobe ⁽¹⁾ or Read/Write ⁽²⁾ Select from PIC MCU
99	AD14	RD6 (PMPD14)	Bidirectional Data<14>
100	AD15	RD7 (PMPD15)	Bidirectional Data<15>
105	AD12	RD12 (PMPD12)	Address<12> from PIC MCU and Bidirectional Data<12>
106	AD13	RD13 (PMPD13)	Address<13> from PIC MCU and Bidirectional Data<13>
109-116	AD0-AD7	RE0/PMPD0-RE7/PMPD7	Address<0:7> from PIC MCU and Bidirectional Data<0:7>

Note 1: PSP Mode 9.

2: PSP Mode 10.

For PSP Modes 9 and 10, the 16-bit bidirectional data is carried by the PMPD0-PMPD15 I/O pins. This requires that all 16 pins be connected. Since the entire 14-bit address bus is multiplexed onto these same pins, the concept of indirect addressing using a limited set of address pins is unnecessary. When using PSP Mode 9 or 10, direct addressing is always performed.

Board Design Theory

Automatic Parallel Interface Pinout Changes

U1, U2, U3, U5, U13 and U14 are bus switches and glue logic for the purpose of changing the pinout of the parallel PICtail Plus board edge contacts. They are unnecessary and should be omitted in ordinary application circuits as the appropriate SPI or PSP interface pins, between the host processor and ENC424J600/624J600, can be directly connected.

Power Supply and Shutdown

U7 and its surrounding components form a 3.3V regulated power supply with shutdown capability. When plugged into a PICDEM.net 2, only a single 5V power supply is available. The MCP1825 LDO regulator supplies the needed 3.3V power for the ENC624J600, associated pull up resistors and the Ethernet magnetics. Because the ENCX24J600 draws considerable current in Sleep mode, it is beneficial in some applications to completely disconnect power from the ENCX24J600 and magnetics instead of using the ENCX24J600 Sleep feature.

Disconnecting power can be achieved by means of the $\overline{\text{SHDN}}$ signal. Care must be taken in software to also tri-state or drive all SPI/PSP interface signals to GND when power is removed to avoid having current enter the ENCX24J600 through the I/O pins.

If an application circuit already has a regulated 3.3V supply available, the MCP1825 can be replaced with a MOSFET to achieve the same shutdown functionality at lower cost, as shown in the following diagram. When using a MOSFET, the C6 and C7 capacitors would be unnecessary.

Replacing MCP1825 with a MOSFET

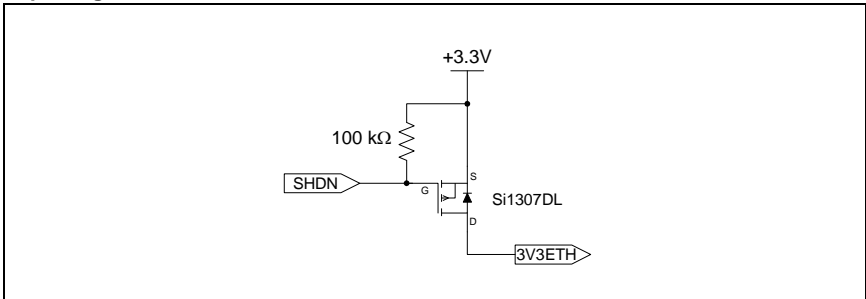

If using a circuit like this, be sure to power all ENCX24J600 VDD pins and the center tap of the Ethernet TX transformer through this power switch. It is invalid to disconnect VDD without removing power from the magnetics.

Ethernet Auto-Crossover

U8 is a quad 2:1 multiplexer bus switch capable of passing analog signals bidirectionally. Its purpose is to swap the TPOUT+/- interface pins with the TPIN+/- interface pins to the RJ-45 connector at run time under software control. If the user plugs in a crossover Ethernet cable when a straight through cable is required, or vice versa, the software can automatically swap the two data pairs via the MDIX signal. This feature permits a true plug-and-play experience for users who may not be aware of the internal differences between a crossover cable and a straight cable.

When MDIX is held low (MDI state), the TPOUT+/- signals are routed to Pins 1 and 2 at the RJ-45 connector, while the TPIN+/- signals are routed to Pins 3 and 6, respectively. These connections are the ordinary default required for end devices. When MDIX is pulled high (MDIX state), the TPOUT+/- signals are routed to Pins 3 and 6, while the TPIN+/- signals appear on Pins 1 and 2, respectively, of the RJ-45 connector. In this state, the wires are crossed as a crossover cable would do externally.

The Microchip TCP/IP Stack software automatically controls the MDIX state (if present) by randomly toggling the MDIX pin when no Ethernet link is detected. Random timing is used to ensure that two identical devices powered up at an identical time will not toggle in lock-step with each other, which would never converge on the correct routing.

If the target application does not need auto-crossover functionality, this feature may be disabled by leaving the MDIX signal tri-stated or by actively driving it low. If complete hardware removal of this feature is desired, unsolder and remove U8, and install 0Ω resistors at R10-R12 and R16.

The Fairchild FST3257 was used in this circuit due to its low-cost, low input/output capacitance and low on resistance. Low capacitance and resistance are necessary to ensure that the switches do not add a significant impedance discontinuity which would distort the high-speed signaling waveform and increase return loss. This circuit was tested to ensure that the transmit waveform in both 10Base-T and 100Base-TX speeds was not significantly altered or in violation of the IEEE 802.3™ standards (excluding the noted deviations in the ENC624J600 silicon errata documentation). Functional receive performance was also tested under worst case cable lengths of 100 meters.

If implementing a similar circuit in end products, take close note of the +5V power requirements. With 10Base-T signaling, the TPOUT+/- and TPIN+/- Common mode is forced, via R6, to roughly $3V3ETH - (80mA * 10\Omega)$ or 2.5V nominally, 2.8V max. The 10Base-T differential signaling adds up to +/-1.4V on top of this Common mode, resulting in a peak voltage of 4.2V that could be applied to the bus switches. The 100Base-TX signaling will also result in peak voltages that exceed 3V3ETH, but not as significantly as 10Base-T mode.

If 5V is not available in the target application, it is possible to create a crude voltage source by making a charge pump off of the ENCX24J600 CLKOUT output, as demonstrated here:

Voltage Source Using the ENCX24J600 CLKOUT Output

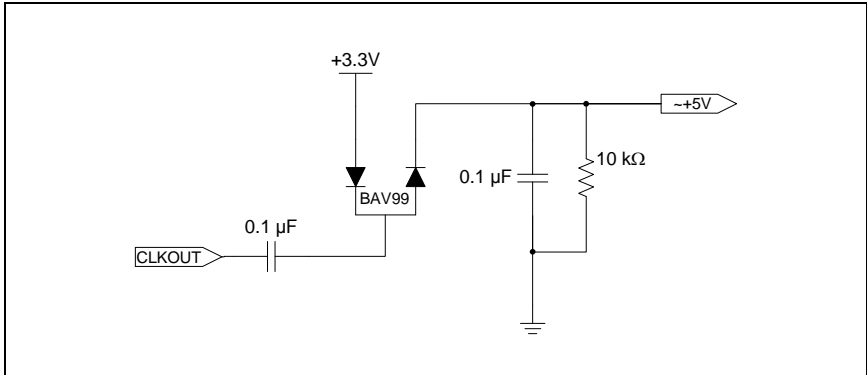

Most bus switches have extremely low-current requirements, so despite the limited current sourcing capability of CLKOUT, it can potentially be used to both generate ~5V required for the bus switches and still be used as a clock source for other circuitry in the application.

PICtail Daughter Board Power Interface

U6, D1 and R4 create a power switching circuit to allow both the PICDEM.net 2 and PIC18 Explorer motherboards to be automatically supported without using jumpers to select between the two. The +5V net powers almost the entire board, including all bus switches, and the 3.3V regulator for the Ethernet controller. Unfortunately, obtaining a 5V supply from the PICtail Daughter Board connectors differs based on the motherboard in use.

For the PICDEM.net 2, 5V is supplied on the VPIC net (J4 Pin 26). However, on the PIC18 Explorer, 5V is always supplied on the 5VEXT net (J3 Pin 4), but only supplied sometimes on VPIC. If a 3.3V PIM is used on the PIC18 Explorer (e.g., PIC18F87J11), then the VPIC net is only powered to 3.3V. This potential voltage difference makes it illegal to directly connect the 5VEXT and VPIC nets together.

When the PIC18 Explorer is used, the D1 shottkey diode provides a minimal voltage drop between the 5VEXT net and the +5V net required to power the Ethernet circuit. The application of voltage on 5VEXT also turns the U6 P-channel MOSFET off, so no current from the +5V net flows back into the PIC18 Explorer through the VPIC net.

When the PICDEM.net 2 is used, the 5VEXT net is not connected. 5V power is supplied on VPIC, which forward biases the body diode in U6, causing the +5V net to begin powering up. Without being driven, the R4 pull-down resistor on the 5VEXT net drops the gate voltage on U6 to GND. Partially powering +5V causes the U6 MOSFET to turn on and essentially short the VPIC and +5V nets together.

The U6 MOSFET could be replaced with another schottky diode, like D1, but the use of a MOSFET allows a wider motherboard voltage tolerance.

Other Information

To obtain the most recent and complete documentation for this demonstration board, including:

- Information Sheet
- Board Description
- Board Schematics
- Source Code
- Application Examples
- Links to Web Seminars

please refer to the Microchip web site: www.microchip.com/ethernet

NOTES:

NOTES:

Americas

Atlanta - 678-957-9614
Boston - 774-760-0087
Chicago - 630-285-0071
Cleveland - 216-447-0464
Dallas - 972-818-7423
Detroit - 248-538-2250
Kokomo - 765-864-8360
Los Angeles - 949-462-9523
Phoenix - 480-792-7200
Santa Clara - 408-961-6444
Toronto - 905-673-0699

Asia/Pacific

Australia - Sydney - 61-2-9868-6733
China - Beijing - 86-10-8528-2100
China - Chengdu - 86-28-8665-5511
China - Hong Kong SAR - 852-2401-1200
China - Nanjing - 86-25-8473-2460
China - Qingdao - 86-532-8502-7355
China - Shanghai - 86-21-5407-5533
China - Shenyang - 86-24-2334-2829
China - Shenzhen - 86-755-8203-2660
China - Wuhan - 86-27-5980-5300
China - Xiamen - 86-592-2388138
China - Xian - 86-29-8833-7252
China - Zhuhai - 86-756-3210040
India - Bangalore - 91-80-3090-4444
India - New Delhi - 91-11-4160-8631
India - Pune - 91-20-2566-1512
Japan - Yokohama - 81-45-471-6166
Korea - Daegu - 82-53-744-4301
Korea - Seoul - 82-2-554-7200
Malaysia - Kuala Lumpur - 60-3-6201-9857
Malaysia - Penang - 60-4-227-8870
Philippines - Manila - 63-2-634-9065
Singapore - 65-6334-8870
Taiwan - Hsin Chu - 886-3-6578-300
Taiwan - Kaohsiung - 886-7-536-4818
Taiwan - Taipei - 886-2-2500-6610
Thailand - Bangkok - 66-2-694-1351

Europe

Austria - Weis - 43-7242-2244-39
Denmark - Copenhagen - 45-4450-2828
France - Paris - 33-1-69-53-63-20
Germany - Munich - 49-89-627-144-0
Italy - Milan - 39-0331-742611
Netherlands - Drunen - 31-416-690399
Spain - Madrid - 34-91-708-08-90
UK - Wokingham - 44-118-921-5869

03/26/09



MICROCHIP

Microchip Technology Inc. • 2355 West Chandler Blvd. • Chandler, AZ 85224-6199
www.microchip.com

The Microchip name and logo and the Microchip logo are registered trademarks of Microchip Technology Incorporated in the U.S.A. and other countries. PICtail and PICDEM.net are trademarks of Microchip Technology Incorporated in the U.S.A. and other countries. All other trademarks mentioned herein are property of their respective companies. © 2009, Microchip Technology Incorporated, Printed in the U.S.A. All Rights Reserved. 07/09

DS51857A



Данный компонент на территории Российской Федерации

Вы можете приобрести в компании MosChip.

Для оперативного оформления запроса Вам необходимо перейти по данной ссылке:

<http://moschip.ru/get-element>

Вы можете разместить у нас заказ для любого Вашего проекта, будь то серийное производство или разработка единичного прибора.

В нашем ассортименте представлены ведущие мировые производители активных и пассивных электронных компонентов.

Нашей специализацией является поставка электронной компонентной базы двойного назначения, продукции таких производителей как XILINX, Intel (ex.ALTERA), Vicor, Microchip, Texas Instruments, Analog Devices, Mini-Circuits, Amphenol, Glenair.

Сотрудничество с глобальными дистрибьюторами электронных компонентов, предоставляет возможность заказывать и получать с международных складов практически любой перечень компонентов в оптимальные для Вас сроки.

На всех этапах разработки и производства наши партнеры могут получить квалифицированную поддержку опытных инженеров.

Система менеджмента качества компании отвечает требованиям в соответствии с ГОСТ Р ИСО 9001, ГОСТ РВ 0015-002 и ЭС РД 009

Офис по работе с юридическими лицами:

105318, г.Москва, ул.Щербаковская д.3, офис 1107, 1118, ДЦ «Щербаковский»

Телефон: +7 495 668-12-70 (многоканальный)

Факс: +7 495 668-12-70 (доб.304)

E-mail: info@moschip.ru

Skype отдела продаж:

moschip.ru

moschip.ru_4

moschip.ru_6

moschip.ru_9