

This drawing involves proprietary design rights of Tyco Electronics Corporation, and all design, manufacture, reproduction, use and sale rights regarding the same are expressly reserved. It is submitted for a specific purpose and the recipient by accepting this drawing, assumes custody and control and agrees to take reasonable precautions: (a) that this drawing will not be copied and reproduced, in whole or in part, or its contents revealed in any manner, or to any person except to meet the purpose for which it was delivered and (b) that any special features peculiar to this design will not be incorporated in other projects without the expressed written permission of Tyco Electronics Corporation.

REVISIONS			
EC	REV	DESCRIPTION	DATE
OS1Q-0211-04	A	INITIAL RELEASE DRAWING (PREVIOUSLY ESK-1692) ADDED INTEGRAL MOLDED POLARITY KEYS, OUTER/INNER	05/27/04
OS1Q-0320-04	B	CHG SOLDER LEAD GEOMETRY AND INCR LEAD LENGTH CHG ELCON PN TO 284-0472-15000B, WAS 284-0472-05000A	09/02/04
OS1Q-0360-04	C	RMV SIGNAL CONTACT NEAREST MOUNTING ALIGN FEATURE	10/18/04
OS1Q-0052-05	D	CHANGE TO REMAIN IN LINE WITH ASSEMBLY REVISION	02/23/05

7. PART NUMBER INFORMATION: TYCO PN 1766200-1 (ELCON PN 284-0472-15000D). REFER TO TYCO PN 1766201-1 (ELCON PN 284-0482-15000D) FOR INFORMATION REGARDING THIS CONNECTOR HAVING AN OPPOSING END 20.5 MM POLARITY KEY DISTANCE.

6. ITEMS PROVIDED TO THIS SPECIFICATION TO BE PERMANENTLY IDENTIFIED PER THE FOLLOWING IDENTIFIER:

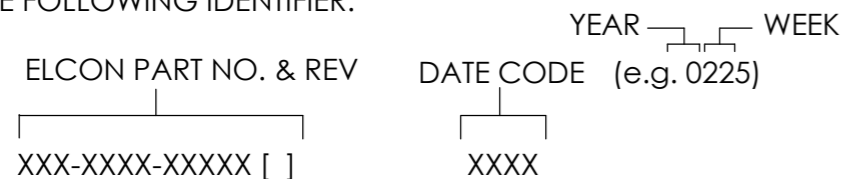

5. OUTLINE SPECIFICATION WHEN USED WITH MATING BOARDS DESIGNED (5 OZ COPPER) FOR COMPARABLE OPERATION

- CURRENT OF 17½ AMPS PER POWER CONTACT AT 30° TEMPERATURE RISE, 250 VOLTS.
- CURRENT OF 25 AMPS PER CONTACT UL
- CONNECTOR HOUSING GATHERABILITY OF ±1.02[.040] AT ZERO DEGREES PRIOR TO MATE.
- MATING FORCES OF 15-20 POUNDS TYPICAL.
- KEY POLARIZED INSULATOR HOUSING
- HEAT DEFLECTION TEMPERATURE, SHORT DURATION, ABOVE 235°C.

4. A REFERENCE DIMENSION (.XXX) IS WITHOUT TOLERANCE AND USED FOR INFORMATION PURPOSES ONLY.

3. FINISHES:
 CONTACT PLATING: SELECTIVE GOLD PLATE PER MIL-G-45204, 0.00076 MM THICK OVER NICKEL 0.00127 THICK.
 PCB TERMINATION: SELECTIVE TIN PLATE PER ASTM-B545, OVER NICKEL PER QQ-N-290 (PRE-PRODUCTION TERMINATION MAY BE TIN/LEAD PLATED)

2. MATERIALS:
 INSULATORS: THERMOPLASTIC, GLASS REINFORCED, COLOR-BLACK
 UL94V-0 FLAMMABILITY RATED
 (PRE-PRODUCTION PLASTIC MAYBE NON-REINFORCED, COLOR NATURAL)
 CONTACTS: COPPER ALLOY

1. PART NUMBER CHANGES AND OR DESIGN CHANGES AFFECTING ITEM INTERCHANGEABILITY REQUIRE PRIOR ELCON APPROVAL AND AUTHORIZATION BY REVISION TO THIS DRAWING.

NOTES: UNLESS OTHERWISE SPECIFIED

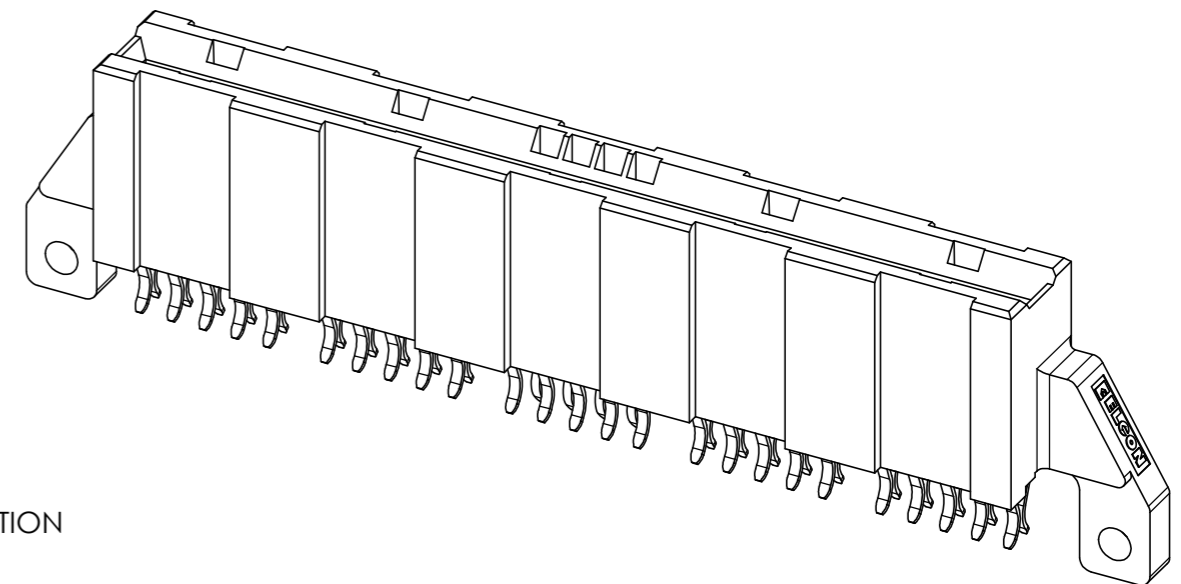

<p>THIRD ANGLE PROJECTION</p> <p>UNLESS OTHERWISE SPECIFIED DIMENSIONS ARE IN MILLIMETERS [INCH]</p> <p>TOLERANCES</p> <p>ANGLES ± 2.0°</p> <p>DECIMALS</p> <p>.XX ± 0.13 [.005]</p> <p>.X ± 0.25 [.01]</p>	<p>DRAWN</p> <p>R. Larsen</p>	<p>DATE</p> <p>05/25/04</p>	<p>tyco Tyco Electronics Corporation Menlo Park, CA 94025</p> <p>ELCON</p>		
	<p>CHECKED</p>		<p>TITLE</p> <p>CROWN EDGE STRADDLEMOUNT CONNECTOR P4S2, POLARITY KEY 23 MM RT PN 284-0472-15000D (TIN PLATED LEADS) PN 284-0472-00900 (PRE-PRODUCTION)</p>		
	<p>APPROVED</p>		<p>APPROVED</p> <p>D. CHAU</p> <p>02/23/05</p>	<p>SIZE</p> <p>B</p>	<p>DWG NUMBER</p> <p>C = 1766200</p>
	<p>DCA APPROVED</p> <p>M. ALIM</p> <p>02/24/05</p>		<p>REV.</p> <p>D</p>		
	<p>FILE NAME</p> <p>SC1766200D.SLDDRW</p>	<p>DWG SCALE: 2=1</p>	<p>SH 1 OF 5</p>		

This drawing involves proprietary design rights of Tyco Electronics Corporation, and all design, manufacture, reproduction, use and sale rights regarding the same are expressly reserved. It is submitted for a specific purpose and the recipient by accepting this drawing, assumes custody and control and agrees to take reasonable precautions: (a) that this drawing will not be copied and reproduced, in whole or in part, or its contents revealed in any manner, or to any person except to meet the purpose for which it was delivered and (b) that any special features peculiar to this design will not be incorporated in other projects without the expressed written permission of Tyco Electronics Corporation.

REVISIONS			
EC	REV	DESCRIPTION	DATE
		SEE SHEET 1	

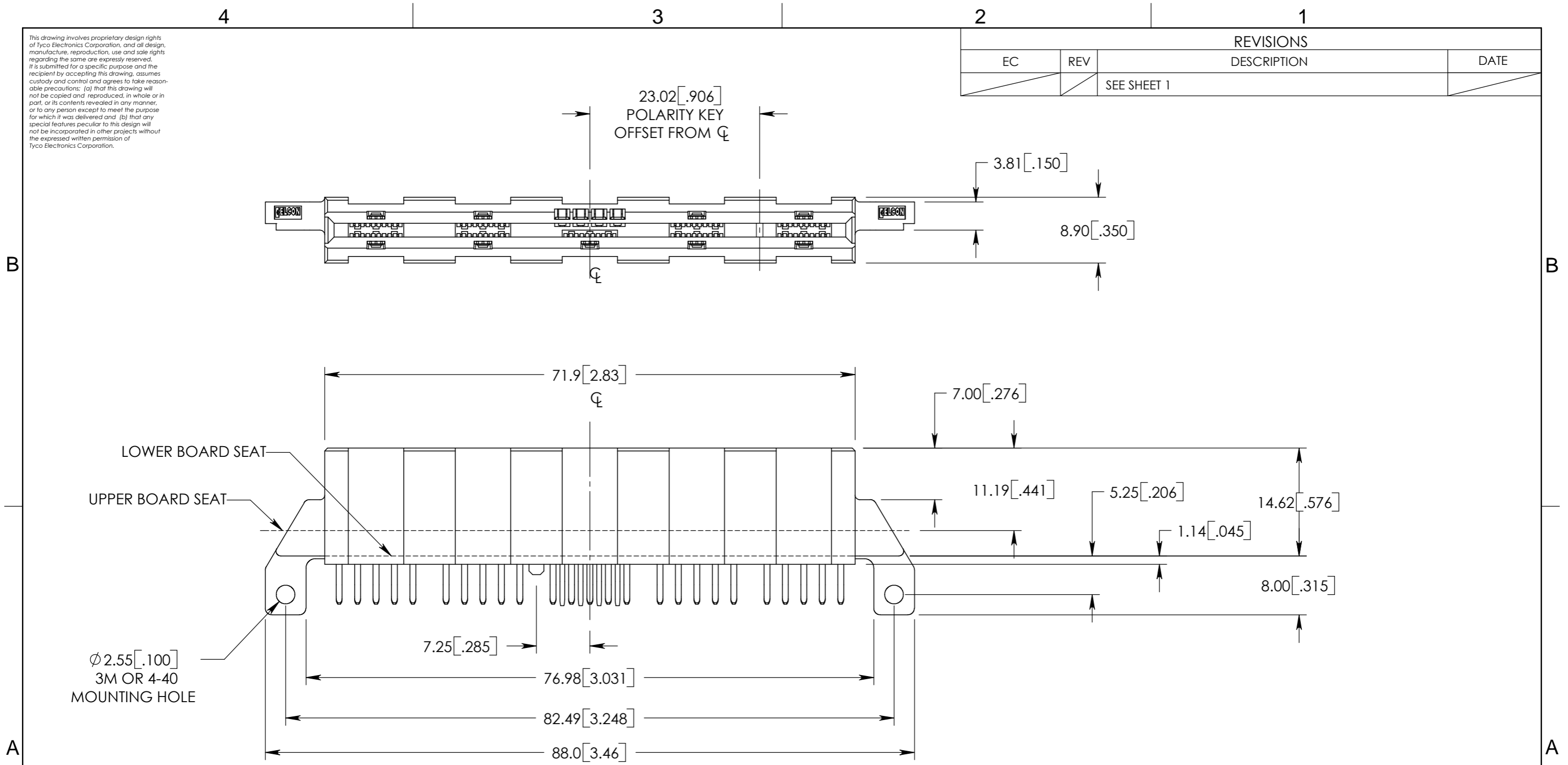

<p>THIRD ANGLE PROJECTION</p> <p>UNLESS OTHERWISE SPECIFIED DIMENSIONS ARE IN MILLIMETERS [INCH]</p> <p>TOLERANCES</p> <p>ANGLES $\pm 2.0^\circ$</p> <p>DECIMALS</p> <p>.XX ± 0.08 [.003]</p> <p>.X ± 0.2 [.008]</p>	<p>DRAWN</p> <p>R. Larsen</p>	<p>DATE</p> <p>05/25/04</p>	<p>tyco Tyco Electronics Corporation Menlo Park, CA 94025</p> <p>ELCON</p> <p>Electronics</p>	<p>TITLE</p> <p>CROWN EDGE STRADDLEMOUNT CONNECTOR P4S2, POLARITY KEY 23 MM RT PN 284-0472-15000D (TIN PLATED LEADS) PN 284-0472-00900 (PRE-PRODUCTION)</p>	
	<p>CHECKED</p>	<p>APPROVED</p>			<p>APPROVED</p> <p>D. CHAU</p> <p>02/23/05</p>
	<p>DCA APPROVED</p> <p>M. ALIM</p> <p>02/24/05</p>	<p>APPROVED</p>	<p>SIZE</p> <p>B</p>	<p>DWG NUMBER</p> <p>C = 1766200</p>	<p>REV</p> <p>D</p>
	<p>FILE NAME</p> <p>SC1766200D.SLDDRW</p>		<p>DWG SCALE: 2 = 1</p>	<p>SH 2 OF 5</p>	

This drawing involves proprietary design rights of Tyco Electronics Corporation, and all design, manufacture, reproduction, use and sale rights regarding the same are expressly reserved. It is submitted for a specific purpose and the recipient by accepting this drawing, assumes custody and control and agrees to take reasonable precautions: (a) that this drawing will not be copied and reproduced, in whole or in part, or its contents revealed in any manner, or to any person except to meet the purpose for which it was delivered and (b) that any special features peculiar to this design will not be incorporated in other projects without the expressed written permission of Tyco Electronics Corporation.

REVISIONS			
EC	REV	DESCRIPTION	DATE
		SEE SHEET 1	

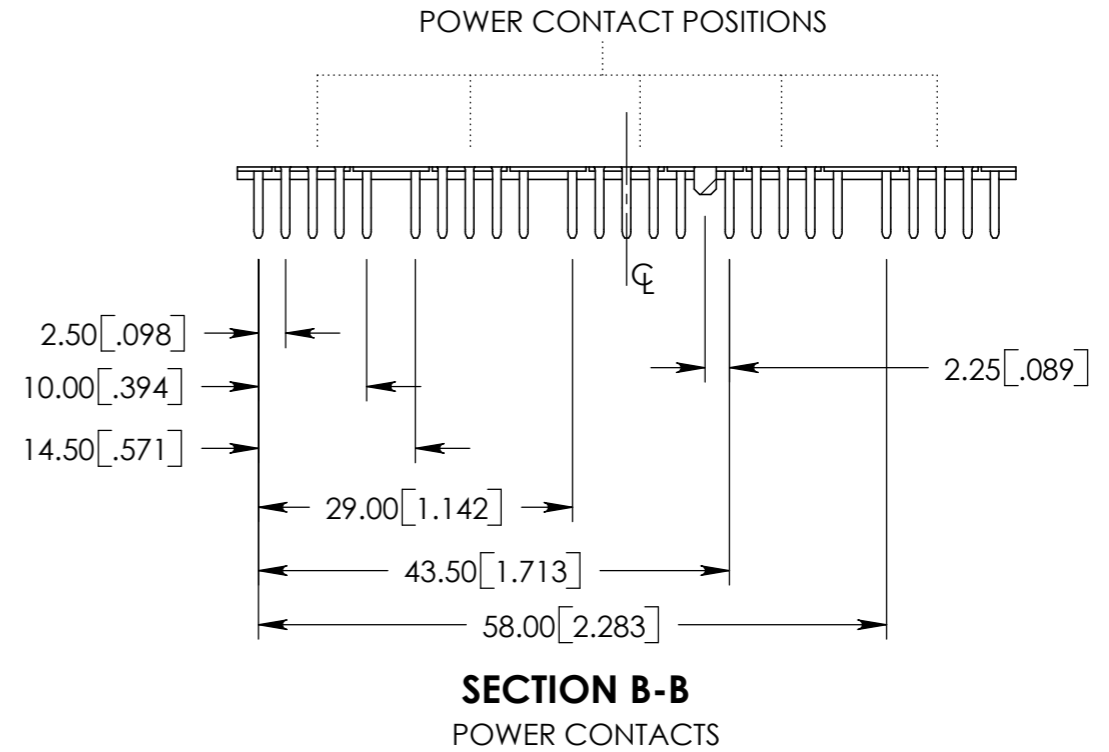
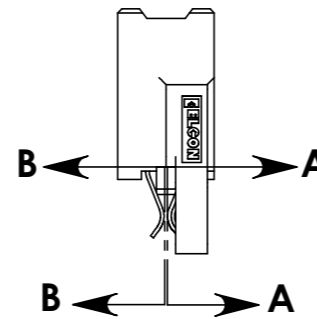
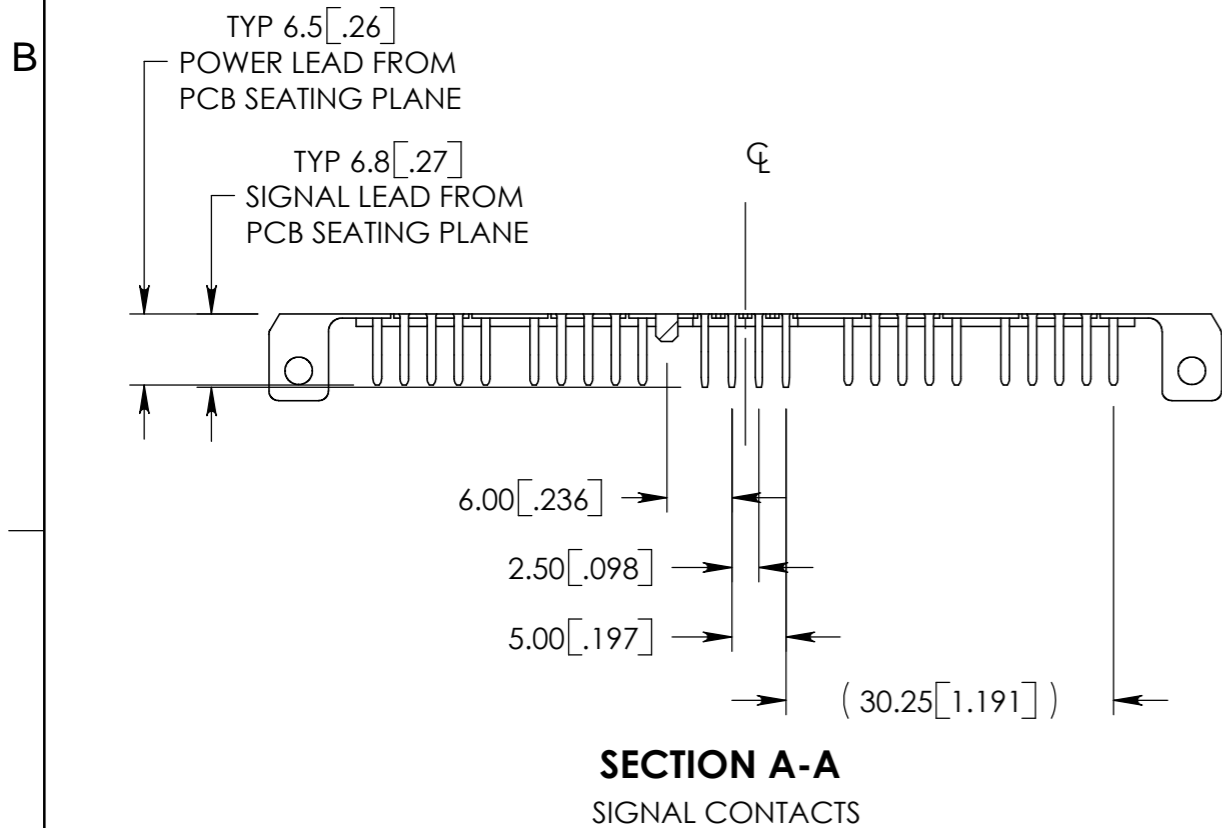

<p>THIRD ANGLE PROJECTION</p> <p>UNLESS OTHERWISE SPECIFIED DIMENSIONS ARE IN MILLIMETERS [INCH]</p> <p>TOLERANCES</p> <p>ANGLES ± 2.0°</p> <p>DECIMALS</p> <p>.XX ± 0.13 [.005]</p> <p>.X ± 0.25 [.01]</p>	<p>← MM OR MM [INCH]</p> <p>INCH</p>	<p>DRAWN</p> <p>R. Larsen</p>	<p>DATE</p> <p>05/25/04</p>	<p>tyco Tyco Electronics Corporation Electronics Menlo Park, CA 94025</p>	<p>ELCON</p>
	<p>CHECKED</p>	<p>APPROVED</p>	<p>TITLE</p> <p>CROWN EDGE STRADDLEMOUNT CONNECTOR P4S2, POLARITY KEY 23 MM RT PN 284-0472-15000D (TIN PLATED LEADS) PN 284-0472-00900 (PRE-PRODUCTION)</p>		
	<p>APPROVED</p> <p>D. CHAU</p> <p>02/23/05</p>	<p>APPROVED</p> <p>M. ALIM</p> <p>02/24/05</p>	<p>SIZE</p> <p>B</p>	<p>DWG NUMBER</p> <p>Ⓒ = 1766200</p>	<p>REV</p> <p>D</p>
	<p>DCA APPROVED</p>	<p>FILE NAME</p> <p>SC1766200D.SLDDRW</p>	<p>DWG SCALE: 1.5 = 1</p>	<p>SH 3 OF 5</p>	

This drawing involves proprietary design rights of Tyco Electronics Corporation, and all design, manufacture, reproduction, use and sale rights regarding the same are expressly reserved. It is submitted for a specific purpose and the recipient by accepting this drawing, assumes custody and control and agrees to take reasonable precautions: (a) that this drawing will not be copied and reproduced, in whole or in part, or its contents revealed in any manner, or to any person except to meet the purpose for which it was delivered and (b) that any special features peculiar to this design will not be incorporated in other projects without the expressed written permission of Tyco Electronics Corporation.

REVISIONS			
EC	REV	DESCRIPTION	DATE
		SEE SHEET 1	

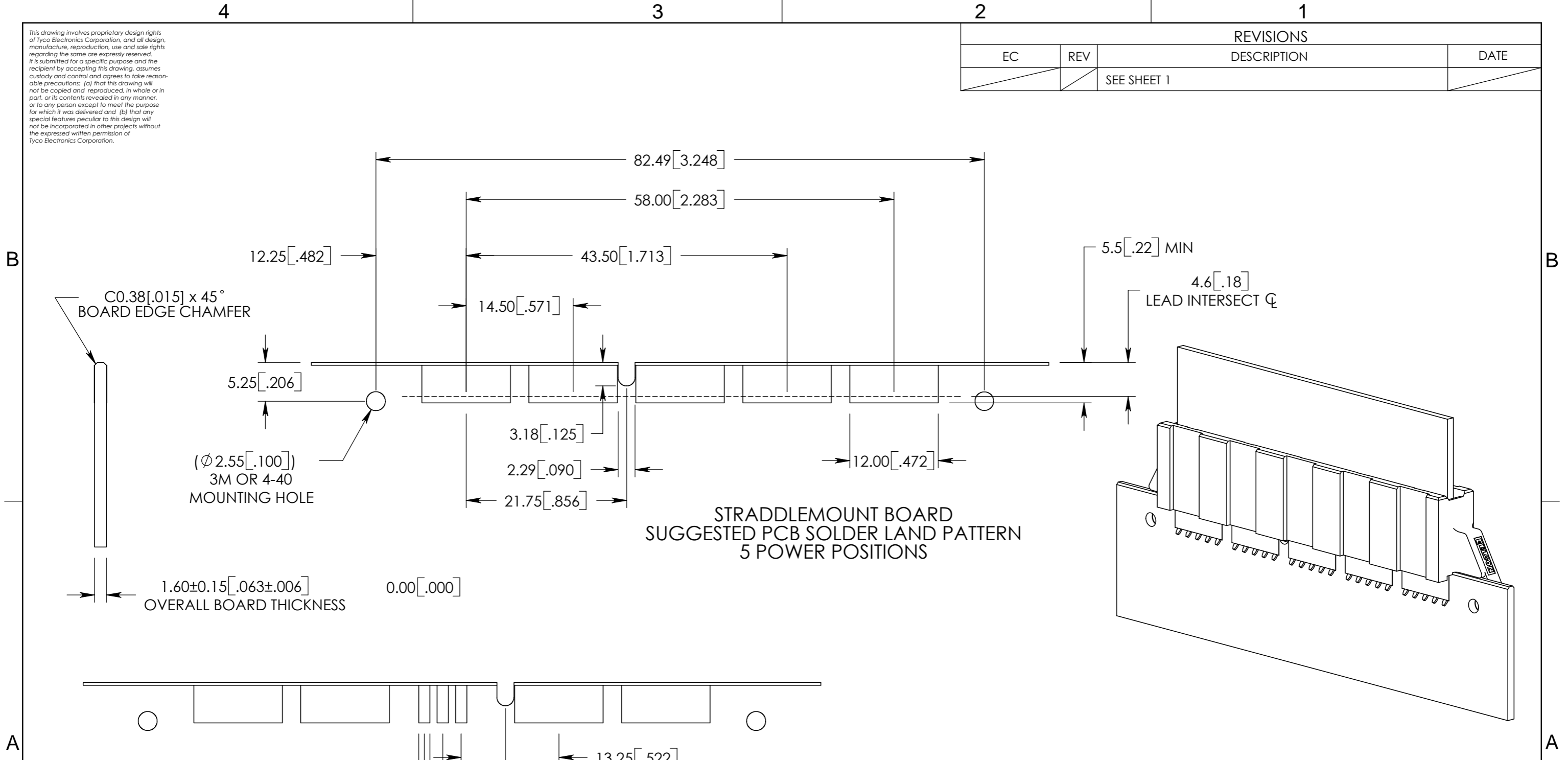

STRADDLEMOUNT BOARD
SUGGESTED PCB SOLDER LAND PATTERN
5 POWER POSITIONS

STRADDLEMOUNT BOARD
SUGGESTED PCB SOLDER LAND PATTERN
4 POWER & 3 SIGNAL POSITIONS

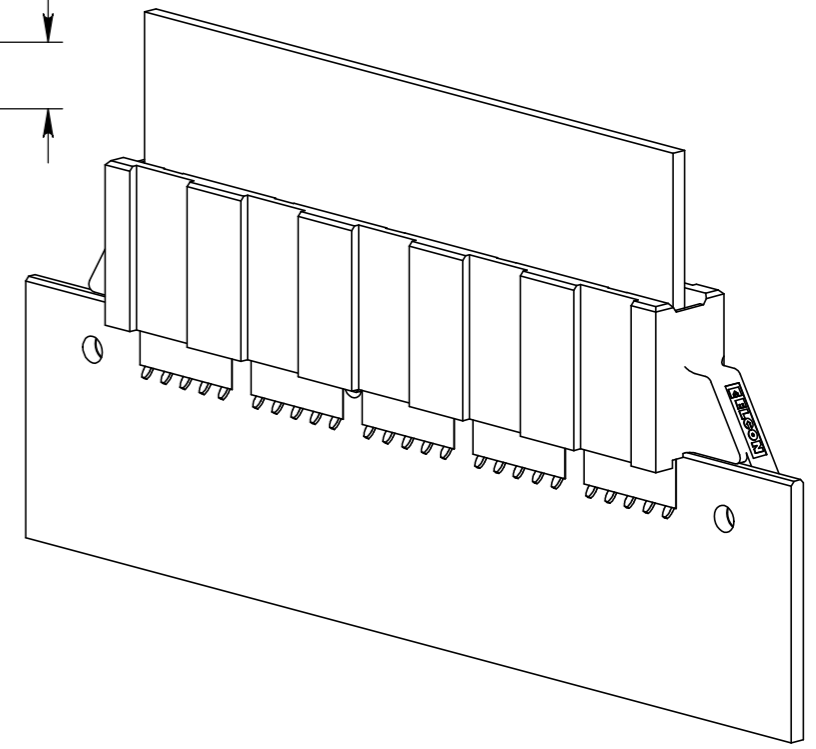

<p>THIRD ANGLE PROJECTION</p> <p>UNLESS OTHERWISE SPECIFIED DIMENSIONS ARE IN MILLIMETERS [INCH]</p> <p>TOLERANCES</p> <p>ANGLES ± 2.0°</p> <p>DECIMALS</p> <p>.XX ± 0.08 [.003]</p> <p>.X ± 0.2 [.008]</p>	<p>DRAWN</p> <p>R. Larsen</p>	<p>DATE</p> <p>05/25/04</p>	<p>tyco Tyco Electronics Corporation Electronics Menlo Park, CA 94025</p>	<p>ELCON</p>	
	<p>CHECKED</p>		<p>TITLE</p> <p>CROWN EDGE STRADDLEMOUNT CONNECTOR P4S2, POLARITY KEY 23 MM RT MOUNTING PCB SOLDER LAND GUIDELINES</p>		
	<p>APPROVED</p> <p>D. CHAU</p>	<p>APPROVED</p> <p>M. ALIM</p>	<p>DATE</p> <p>02/23/05</p>	<p>SIZE</p> <p>B</p>	<p>DWG NUMBER</p> <p>C = 1766200</p>
	<p>FILE NAME</p> <p>SC1766200D.SLDDRW</p>	<p>DWG SCALE: 2 = 1</p>	<p>REV</p> <p>D</p>	<p>SH 4 OF 5</p>	

This drawing involves proprietary design rights of Tyco Electronics Corporation, and all design, manufacture, reproduction, use and sale rights regarding the same are expressly reserved. It is submitted for a specific purpose and the recipient by accepting this drawing, assumes custody and control and agrees to take reasonable precautions: (a) that this drawing will not be copied and reproduced, in whole or in part, or its contents revealed in any manner, or to any person except to meet the purpose for which it was delivered and (b) that any special features peculiar to this design will not be incorporated in other projects without the expressed written permission of Tyco Electronics Corporation.

REVISIONS			
EC	REV	DESCRIPTION	DATE
		SEE SHEET 1	

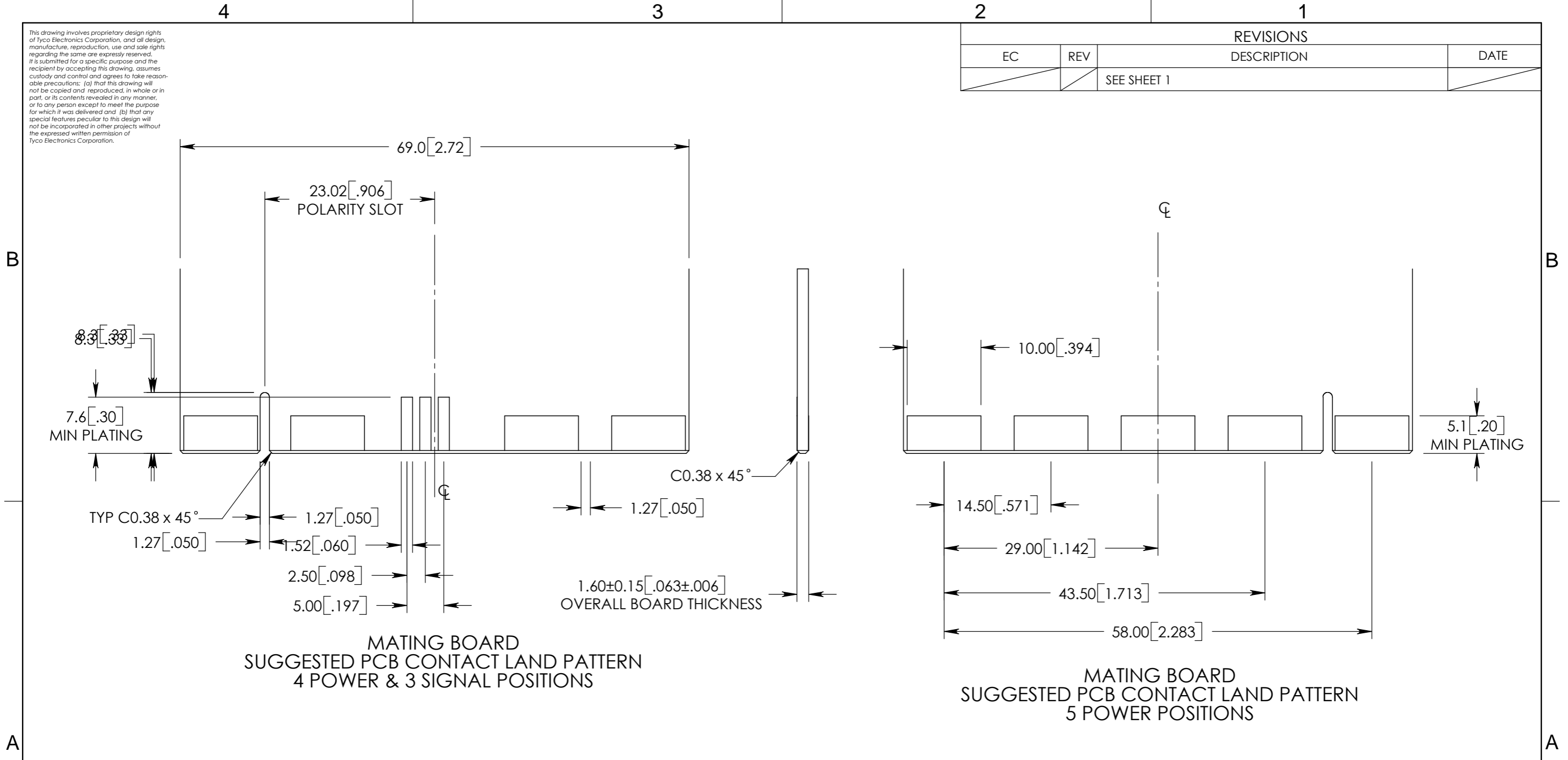

MATING BOARD
SUGGESTED PCB CONTACT LAND PATTERN
4 POWER & 3 SIGNAL POSITIONS

MATING BOARD
SUGGESTED PCB CONTACT LAND PATTERN
5 POWER POSITIONS

<p>THIRD ANGLE PROJECTION</p> <p>UNLESS OTHERWISE SPECIFIED DIMENSIONS ARE IN MILLIMETERS [INCH]</p> <p>TOLERANCES</p> <p>ANGLES ± 2.0°</p> <p>DECIMALS</p> <p>.XX ± 0.08 [.003]</p> <p>.X ± 0.2 [.008]</p>	<p>← MM OR MM [INCH]</p> <p>← INCH</p>	<p>DRAWN</p> <p>R. Larsen</p>	<p>DATE</p> <p>05/25/04</p>	<p>tyco Tyco Electronics Corporation Electronics Menlo Park, CA 94025</p>	<p>ELCON</p>	
	<p>CHECKED</p>	<p>APPROVED</p>	<p>APPROVED</p> <p>D. CHAU</p> <p>02/23/05</p>	<p>TITLE</p> <p>CROWN EDGE STRADDLEMOUNT CONNECTOR P4S2, POLARITY KEY 23 MM RT MATING PCB CONTACT LAND GUIDELINES</p>		
	<p>DCA APPROVED</p> <p>M. ALIM</p> <p>02/24/05</p>	<p>SIZE</p> <p>B</p>	<p>DWG NUMBER</p> <p>C = 1766200</p>	<p>REV</p> <p>D</p>		
	<p>FILE NAME</p> <p>SC1766200D.SLDDRW</p>	<p>DWG SCALE: 2 = 1</p>	<p>SH 5 OF 5</p>			

Данный компонент на территории Российской Федерации

Вы можете приобрести в компании MosChip.

Для оперативного оформления запроса Вам необходимо перейти по данной ссылке:

<http://moschip.ru/get-element>

Вы можете разместить у нас заказ для любого Вашего проекта, будь то серийное производство или разработка единичного прибора.

В нашем ассортименте представлены ведущие мировые производители активных и пассивных электронных компонентов.

Нашей специализацией является поставка электронной компонентной базы двойного назначения, продукции таких производителей как XILINX, Intel (ex.ALTERA), Vicor, Microchip, Texas Instruments, Analog Devices, Mini-Circuits, Amphenol, Glenair.

Сотрудничество с глобальными дистрибьюторами электронных компонентов, предоставляет возможность заказывать и получать с международных складов практически любой перечень компонентов в оптимальные для Вас сроки.

На всех этапах разработки и производства наши партнеры могут получить квалифицированную поддержку опытных инженеров.

Система менеджмента качества компании отвечает требованиям в соответствии с ГОСТ Р ИСО 9001, ГОСТ РВ 0015-002 и ЭС РД 009

Офис по работе с юридическими лицами:

105318, г.Москва, ул.Щербаковская д.3, офис 1107, 1118, ДЦ «Щербаковский»

Телефон: +7 495 668-12-70 (многоканальный)

Факс: +7 495 668-12-70 (доб.304)

E-mail: info@moschip.ru

Skype отдела продаж:

moschip.ru

moschip.ru_4

moschip.ru_6

moschip.ru_9