

Audio Control Switch Clap On/Off Model GSK-409

Classified as a remote controlled circuit this product uses an audio signal (clap on) to activate the on/off function of the switch. A sensitivity/volume controlled microphone picks up audio signal activating a relay generating an electrical signal to the switch.

Technical Specifications

- Power Source: 12 VDC
- Power Consumption: 50 mA max.
- Sensitivity Adjustment: potentiometer
- Maximum Load: 10 A, 125 VAC or 5 A, 220 VAC
- PCB Dimensions: 2.92 x 1.49 inches

Operating Principles

This circuit utilizes a sensitivity microphone to obtain an audio signal and a flip-flop circuit to turn the switch to the on and off position. The audio signal enters from the microphone to transistor 1 through capacitor 2 entering variable resistor 1 allowing sensitivity adjustments. The collector of transistor 2 is connected through capacitor 3 and 4 creating a flip-flop sector comprising of transistor 3 and 4 both taking turn functioning to the signal transmitted by the microphone. The transmittal of an audio signal through transistor 1 and 2 causes the collector of transistor 2 to be amplified creating a momentary low voltage while current at the base of transistor 4 is drawn through diode 2 and capacitor 4 to ground at collector transistor 2 making transistor 4 stop inducing current. The higher voltage will cause transistor 3 to draw current through the base of transistor 4 and ground causing transistor 3 to work in place of transistor 4. At this point the relay will release the contact face so the LED will be turned off. Transistor 4 will be inactive until an audio signal is present to cause transistor 3 to stop induction and then transistor 4 will start functioning.

PCB Assembly

Please refer to Figures 1, 2, and 3 for aid in component placement. It is recommended to start with lower components i.e. diodes, resistors, electrolyte capacitors, and transistors. Be careful to check polarity with Figure 3 before soldering. Take extra precaution to ensure electrolytic capacitors are inserted correctly. If a problem is detected it is best too use a desoldering pump or desoldering braids to remove component. This will minimize potential damage to the printed circuit board.

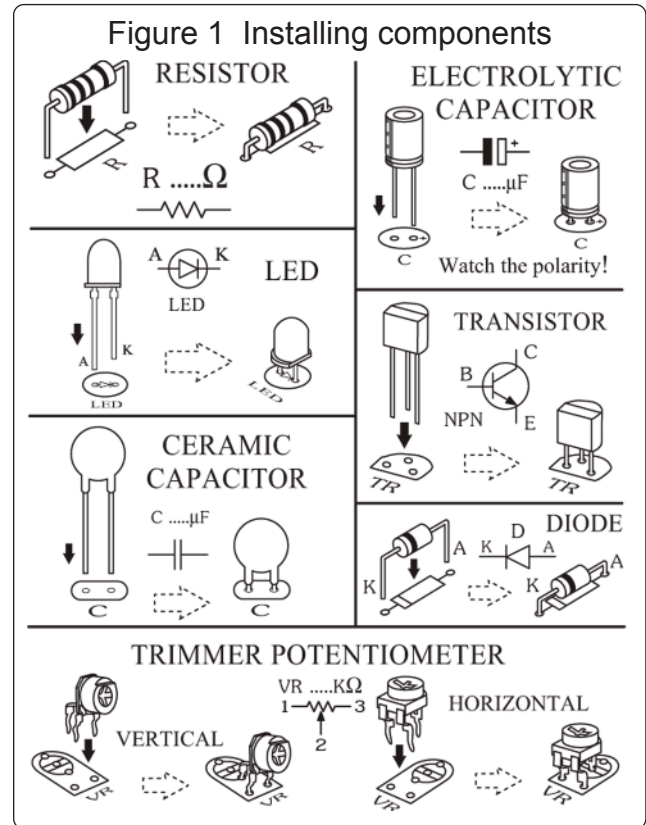

Testing

Connect the 12VDC power source and adjust variable resistor 1 to just past neutral. The LED may be on or off; test by clapping your hands; LED should change from previous condition; clap hands once more and LED should return to original position. The LED should go on and off by clapping your hands if so, the circuit is working. Connect the audio control switch at "OUT" terminal and connect the unit to the "IN" terminal.

Troubleshooting

The main cause of problems will come from misplaced components or faulty soldering. Utilize figure 2 and 3 to ensure proper placement, polarity and then check solder points for connectivity.

Accessories

Use GSB-04 (sold separately) to house the PCB and batteries.

Figure 2 Audio control switch circuit

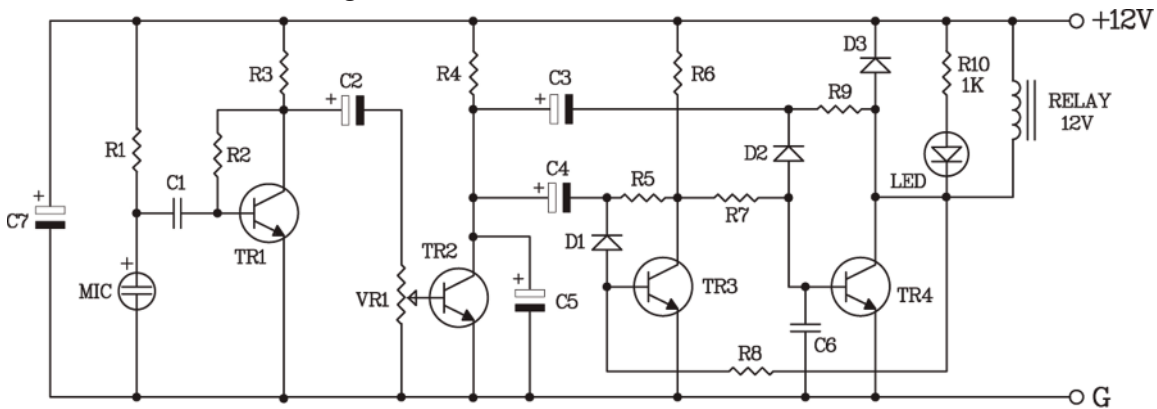
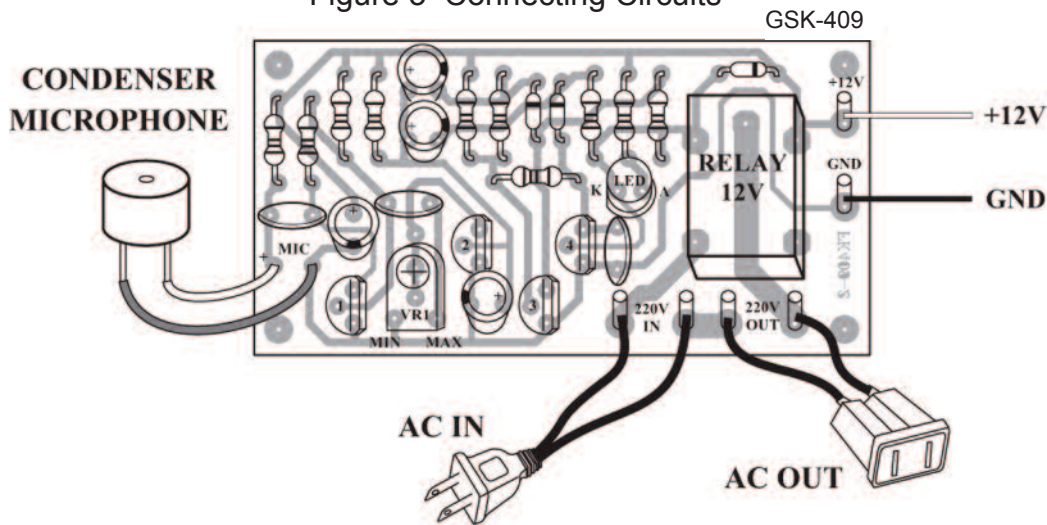

Figure 3 Connecting Circuits



Resistors

R1, R10	1 kΩ	brown – black – red – gold
R2	1 MΩ	brown – black – green – gold
R3, R8	10 kΩ	brown – black – orange – gold
R4	56 kΩ	green – blue – orange – gold
R5, R9	47 kΩ	yellow – violet – orange – gold
R6	3 kΩ	orange – black – red – gold
R7	5 kΩ	green – black – red – gold

Potentiometer

VR1	103 or 14 or 10 kΩ
-----	--------------------

Ceramic Capacitors

C1	104 or 0.1 μF
C6	273 or 0.027 μF

Electrolytic Capacitors

C2	0.1 μF
C3, C4, C5	2.2 μF
C7	10 μF

Transistor

TR1, TR2, TR3, TR4	C458, C828, C945, C1815
--------------------	-------------------------

Diodes

D1, D2, D3	1N4148
------------	--------

Данный компонент на территории Российской Федерации

Вы можете приобрести в компании MosChip.

Для оперативного оформления запроса Вам необходимо перейти по данной ссылке:

<http://moschip.ru/get-element>

Вы можете разместить у нас заказ для любого Вашего проекта, будь то серийное производство или разработка единичного прибора.

В нашем ассортименте представлены ведущие мировые производители активных и пассивных электронных компонентов.

Нашей специализацией является поставка электронной компонентной базы двойного назначения, продукции таких производителей как XILINX, Intel (ex.ALTERA), Vicor, Microchip, Texas Instruments, Analog Devices, Mini-Circuits, Amphenol, Glenair.

Сотрудничество с глобальными дистрибьюторами электронных компонентов, предоставляет возможность заказывать и получать с международных складов практически любой перечень компонентов в оптимальные для Вас сроки.

На всех этапах разработки и производства наши партнеры могут получить квалифицированную поддержку опытных инженеров.

Система менеджмента качества компании отвечает требованиям в соответствии с ГОСТ Р ИСО 9001, ГОСТ РВ 0015-002 и ЭС РД 009

Офис по работе с юридическими лицами:

105318, г.Москва, ул.Щербаковская д.3, офис 1107, 1118, ДЦ «Щербаковский»

Телефон: +7 495 668-12-70 (многоканальный)

Факс: +7 495 668-12-70 (доб.304)

E-mail: info@moschip.ru

Skype отдела продаж:

moschip.ru

moschip.ru_4

moschip.ru_6

moschip.ru_9