

3M™ HM PRESS-FIT HEADER, 8-ROW, HM SERIES  
FOR HARD METRIC APPLICATIONS

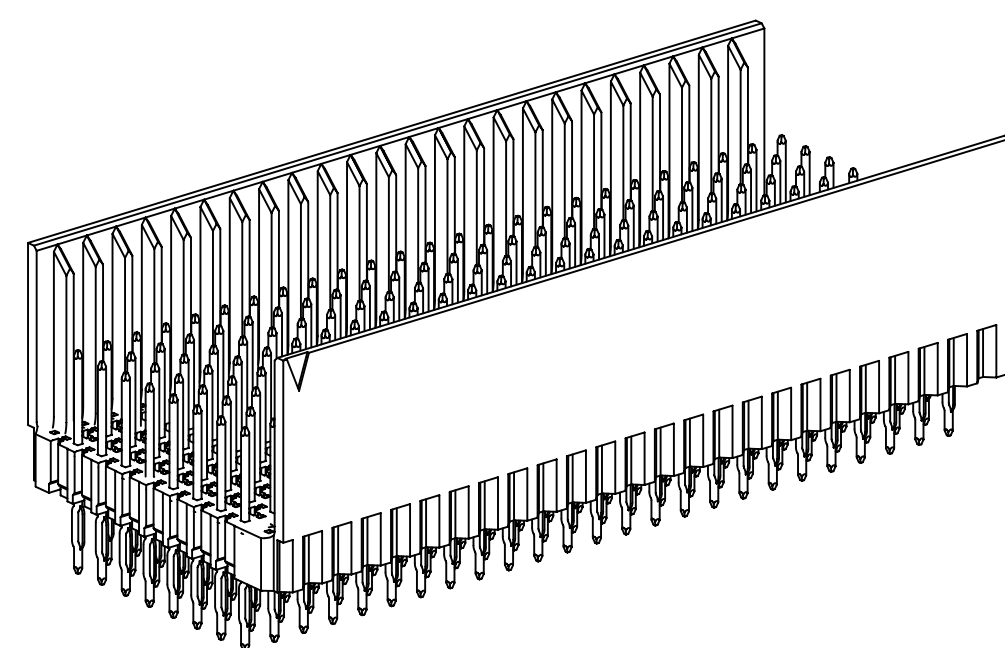

HM-H200E1-8CX1  
HM-H244E2-8BX1

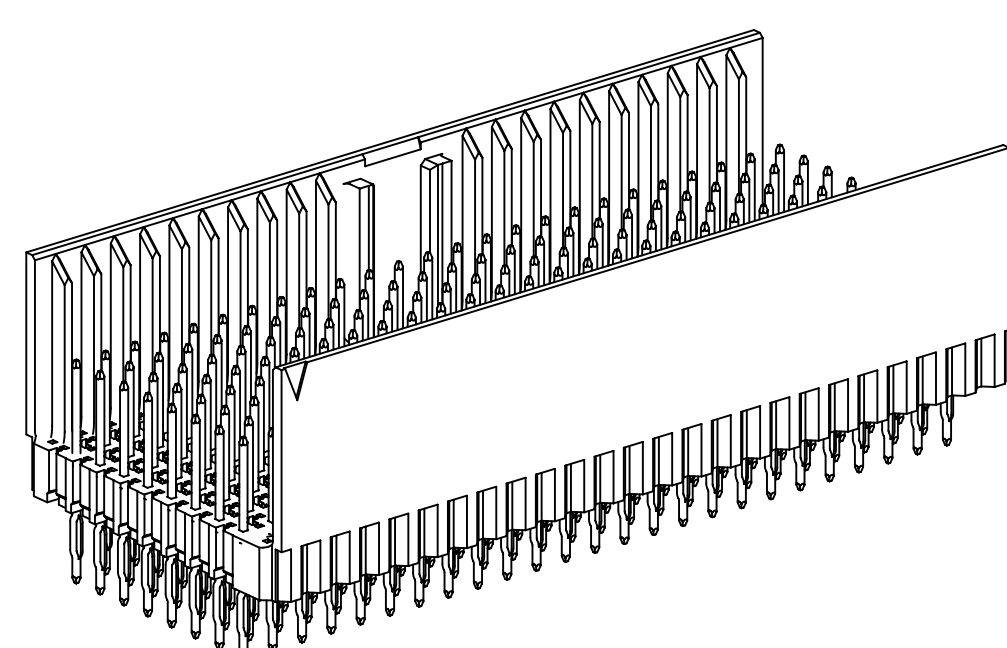

HM-H200DE1-8CX1  
HM-H244DE2-8BX1

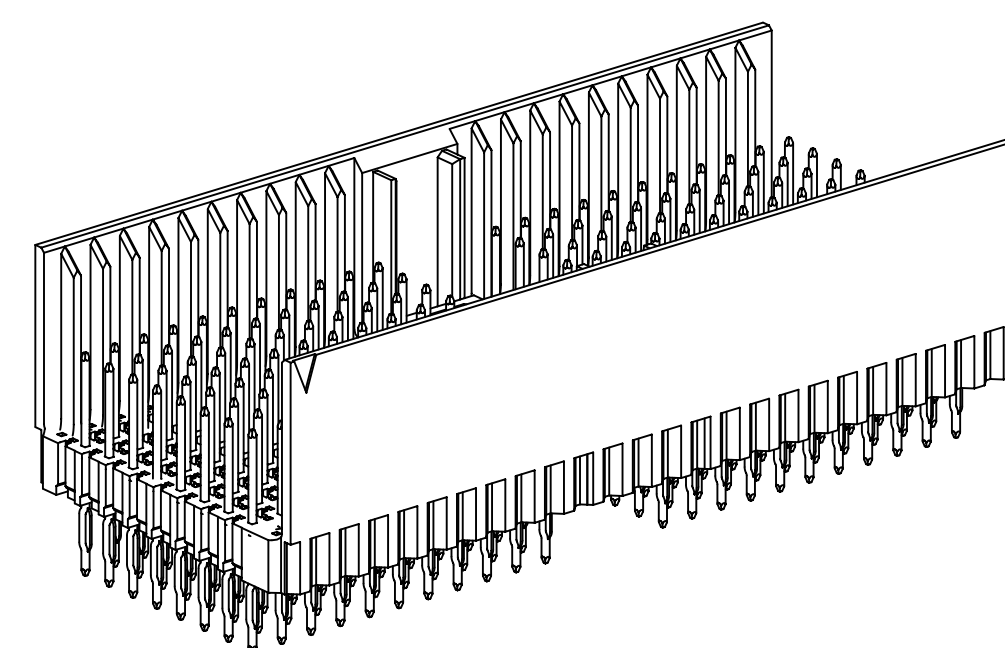

HM-H176D1-8CX1  
HM-H220D2-8BX1

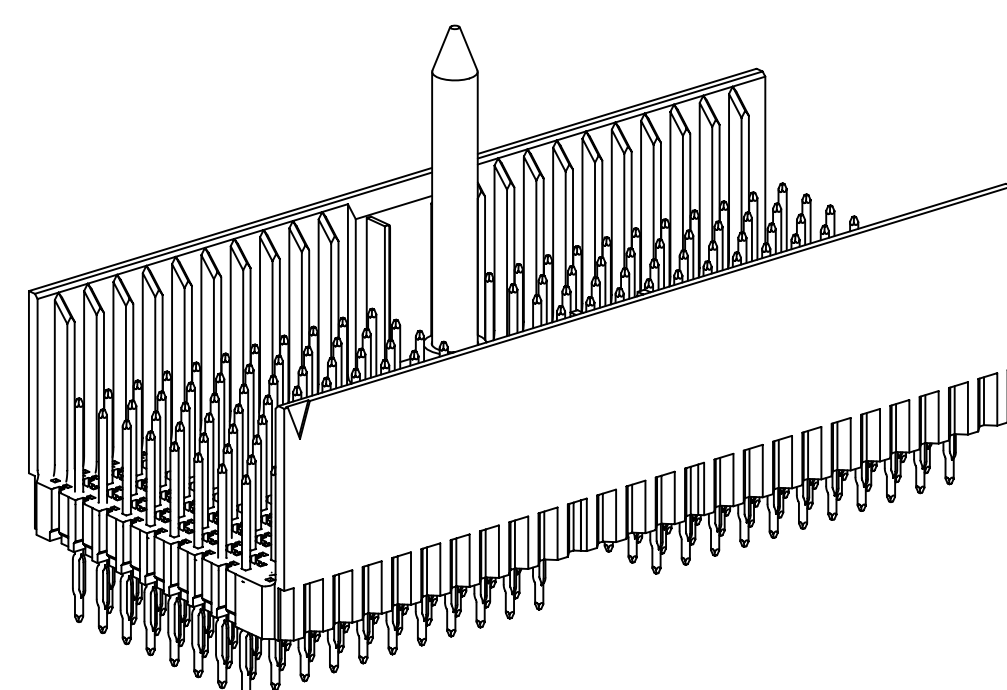

HM-H176DG1-8CX1  
HM-H220DG2-8BX1

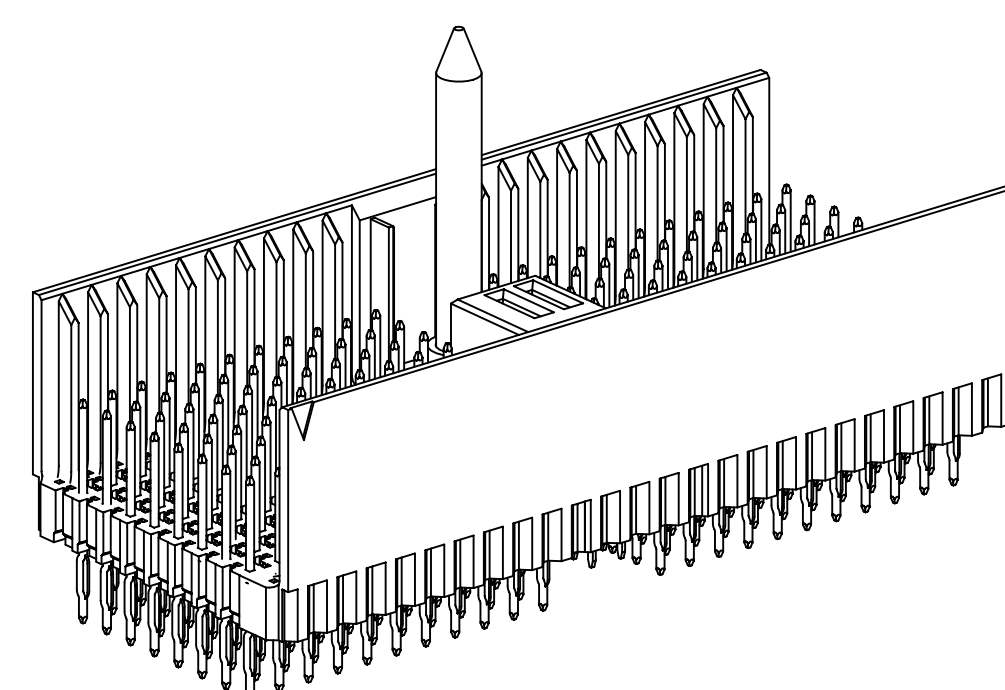

HM-H176DPWR1-8CX1  
HM-H220DPWR2-8BX1

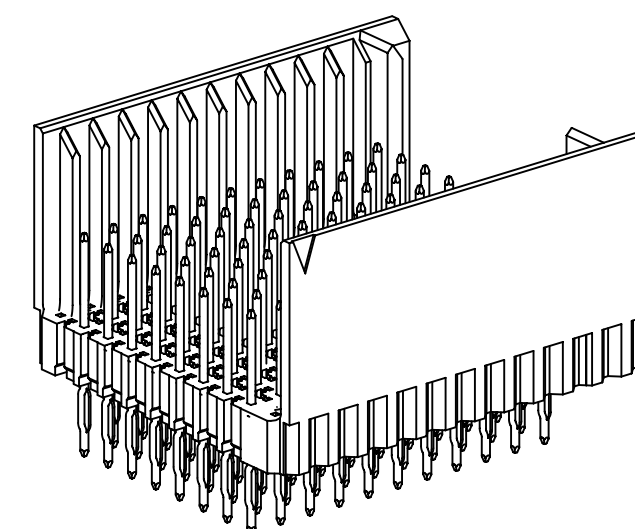

HM-H088FL1-8CX1  
HM-H110FL2-8BX1

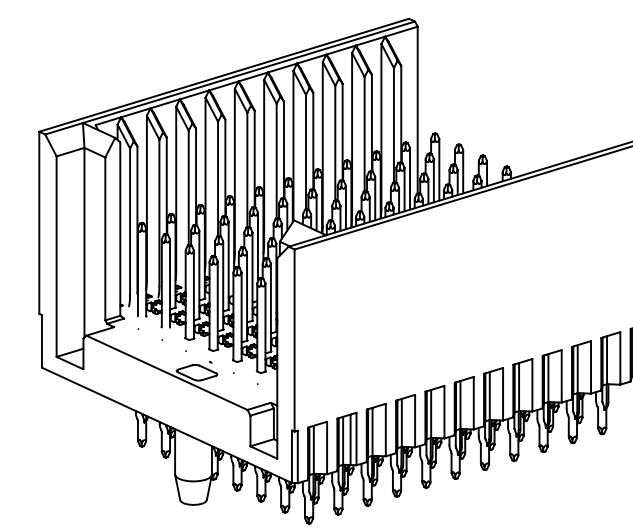

HM-H088FR1-8CX1  
HM-H110FR2-8BX1

(UNLESS OTHERWISE SHOWN)  
ORDERING INFORMATION  
(ROWS I AND Z NOT LOADED)

HM-HXXXXX1-8CX1-XXXXX

HEADER POSITION AND TYPE      TAIL STYLE:  
P = PRESS-FIT TAIL  
S = SOLDER TAIL      PLATING

(UNLESS OTHERWISE SHOWN)  
ORDERING INFORMATION  
(ROWS I AND Z LOADED, 8.3MM MATE LENGTH)

HM-HXXXXX2-8BX1-XXXXX

HEADER POSITION AND TYPE      TAIL STYLE:  
P = PRESS-FIT TAIL  
S = SOLDER TAIL      PLATING

PLATING SPECIFICATIONS:

TG30L = .76µM [30µIN] MIN. GOLD ON CONTACT AREA, LUBRICATED  
2.54µM [100µIN] MIN. TIN/LEAD ON TERMINAL AREA (RIA C2 & E2 APPLY)  
1.27µM [50µIN] MIN. NICKEL ALL OVER.  
TYPICALLY HIGHER MAKE ORDER QUANTITIES AS COMPARED TO TG30.

TG30 = .76µM [30µIN] MIN. GOLD ON CONTACT AREA  
2.54µM [100µIN] MIN. TIN/LEAD ON TERMINAL AREA (RIA C2 & E2 APPLY)  
1.27µM [50µIN] MIN. NICKEL ALL OVER.  
STANDARD OPTION.

TG50 = 1.27µM [50µIN] MIN. GOLD ON CONTACT AREA, LUBRICATED  
2.54µM [100µIN] MIN. TIN/LEAD ON TERMINAL AREA (RIA C2 & E2 APPLY)  
1.27µM [50µIN] MIN. NICKEL ALL OVER.  
NON-STANDARD OPTION (AVAILABLE WITH LONGER LEAD TIMES AND HIGHER MAKE ORDER QUANTITIES, MOQ)

KR = .76µM [30µIN] MIN. GOLD ON CONTACT AREA  
2.54µM [100µIN] MIN. MATTE TIN ON TERMINAL AREA (RIA C2 & E2 APPLY)  
1.27µM [50µIN] MIN. NICKEL ALL OVER.

- \* MODULAR/SCALABLE FORMAT IEC 61076-4-101
- \* PRESS-FIT OF SOLDER TAIL VERSION
- \* 101 MATED LINES PER INCH
- \* SHIPS WITH PROTECTIVE CAP, WHICH ALSO SERVES AS AN INSERTION TOOL
- \* END-TO-END STACKABLE WITH 8 ROW 3M™ HM AND HSHM PRODUCTS
- \* INTEGRATED GUIDE AND GUIDE PIN
- \* MULTI-PURPOSE CENTER (MPC) KEYING AND GUIDANCE
- \* FOUR INTEGRATED 8.25 A POWER CONTACTS AND GUIDE PIN

- NOTES
1. MATERIAL:  
PLASTIC: HIGH TEMP LCP, UL94V-0  
PINS: COPPER ALLOY.
  2. REGULATORY INFORMATION:  
ROHS COMPLIANT. SEE THE REGULATORY INFORMATION APPENDIX (RIA) IN THE "ROHS COMPLIANCE" SECTION OF WWW.3MCONNECTORS.COM FOR COMPLIANCE INFORMATION (RIA E1 & C1 APPLY)
  3. IN THE EVENT OF CONFLICT BETWEEN THIS DATA AND THAT CONTAINED IN THE PRODUCT SPECIFICATION, THE PRODUCT SPECIFICATION TAKES PRECEDENT.

MECHANICAL:

NORMAL FORCE (NOMINAL): .57N [58g] SIGNAL  
ENGAGEMENT FORCE (NOMINAL): .32N [33g] SIGNAL  
SEPARATION FORCE (NOMINAL): .20N [20g] SIGNAL  
WIPE (NOMINAL, SHORTEST CONTACT): 2.67 [.105] SIGNAL  
MATE/UNMATE CYCLES: 250  
APPLICATION: THIS MODULE IS NOT SUITABLE FOR STAND-ALONE USE. (REFER TO IEC-61076-4-101)

ELECTRICAL:

CURRENT RATING (FULLY LOADED): 1A @ 70°C SIGNAL  
INSULATION RESISTANCE: 1 X 10<sup>4</sup> MΩ @ 100 V<sub>DC</sub>  
WITHSTANDING VOLTAGE: 750V<sub>RMS</sub>

ENVIRONMENTAL:

TEMPERATURE RATING: -55°C TO 125°C  
PROCESS RATING: MAX. 260°C (PER J-STD-020C)  
WITHSTANDING VOLTAGE: 1 (PER J-STD-020C)

3M™ ELECTRONIC SOLUTIONS DIVISION  
INTERCONNECT SOLUTIONS  
<http://www.3mconnectors.com>

3M IS A TRADEMARK OF 3M COMPANY.  
FOR TECHNICAL, SALES OR ORDERING INFORMATION CALL 800-225-5373

**CAUS**  
UL FILE NO: E68080

DESIGN REFERENCE		NEXT ASSEMBLY		REV	ECO	ISSUE DATE AND DESCRIPTION	DRFT	CHKD
CAGD		CAGD		001		MAR 28, 2012		
DIVISION		DIVISION CODE		DATE		DATE		
Interconnect Solutions		ISD		T. SUNIGA		MAR 28, 2012		
DO NOT SCALE DRAWING	SCALE 5/2	TOLERANCES EXCEPT AS NOTED		3M		© 3M COPYRIGHT 2012		
THIRD ANGLE PROJECTION		INCHES		St. Paul, MN 55144		This document and the information it contains are 3M property and may not be reproduced or further distributed without 3M permission, or used or disclosed other than for 3M authorized purposes. All rights reserved.		
INTERPRET PER ASME Y14.5 - 1994		MILLIMETERS		TITLE		HM PRESS-FIT HEADER, 8-ROW, HM SERIES		
MAX SURFACE ROUGHNESS		.00 ± .13		CAGE NUMBER		D78-5100-2517-0		
SURFACES		.000 ±		DRAWING NO.		78-5100-2517-0		
MARKED ONLY		ANGLES		REV.		A		

78-5100-2517-0  
DRAWING NUMBER

REVISION

A

B

C

D

A

SHT 1 OF 4

3M™ HM PRESS-FIT HEADER, 8-ROW, HM SERIES  
FOR HARD METRIC APPLICATIONS

NOTES  
1 CAPS TO BE REMOVED AFTER PRESS-FIT INSTALLATION PROCESS.

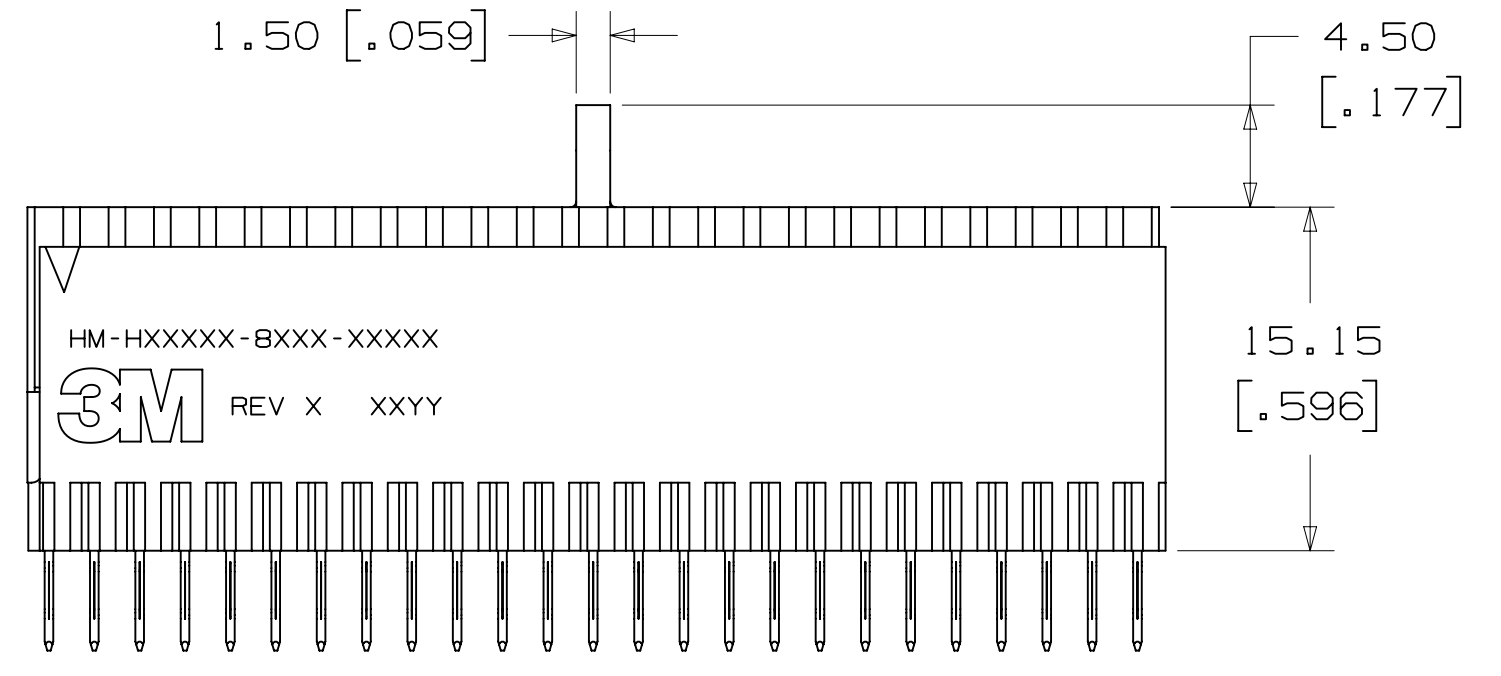
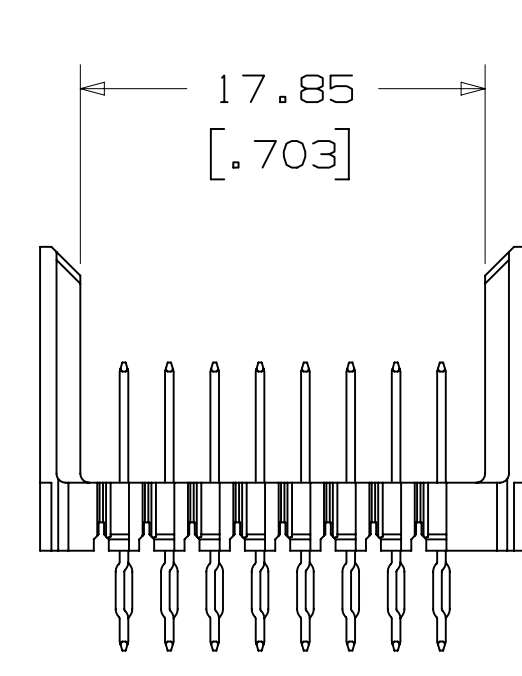
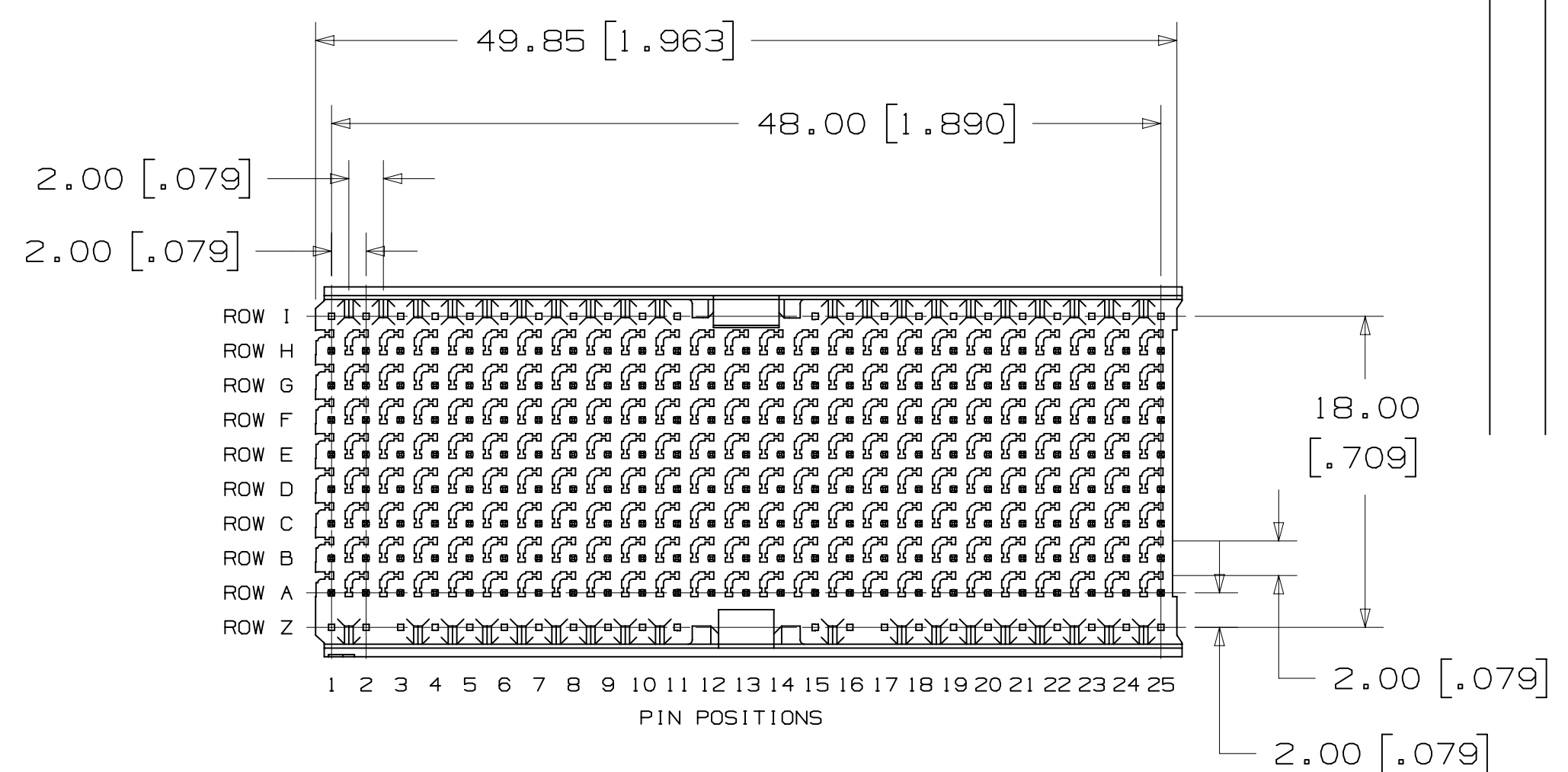
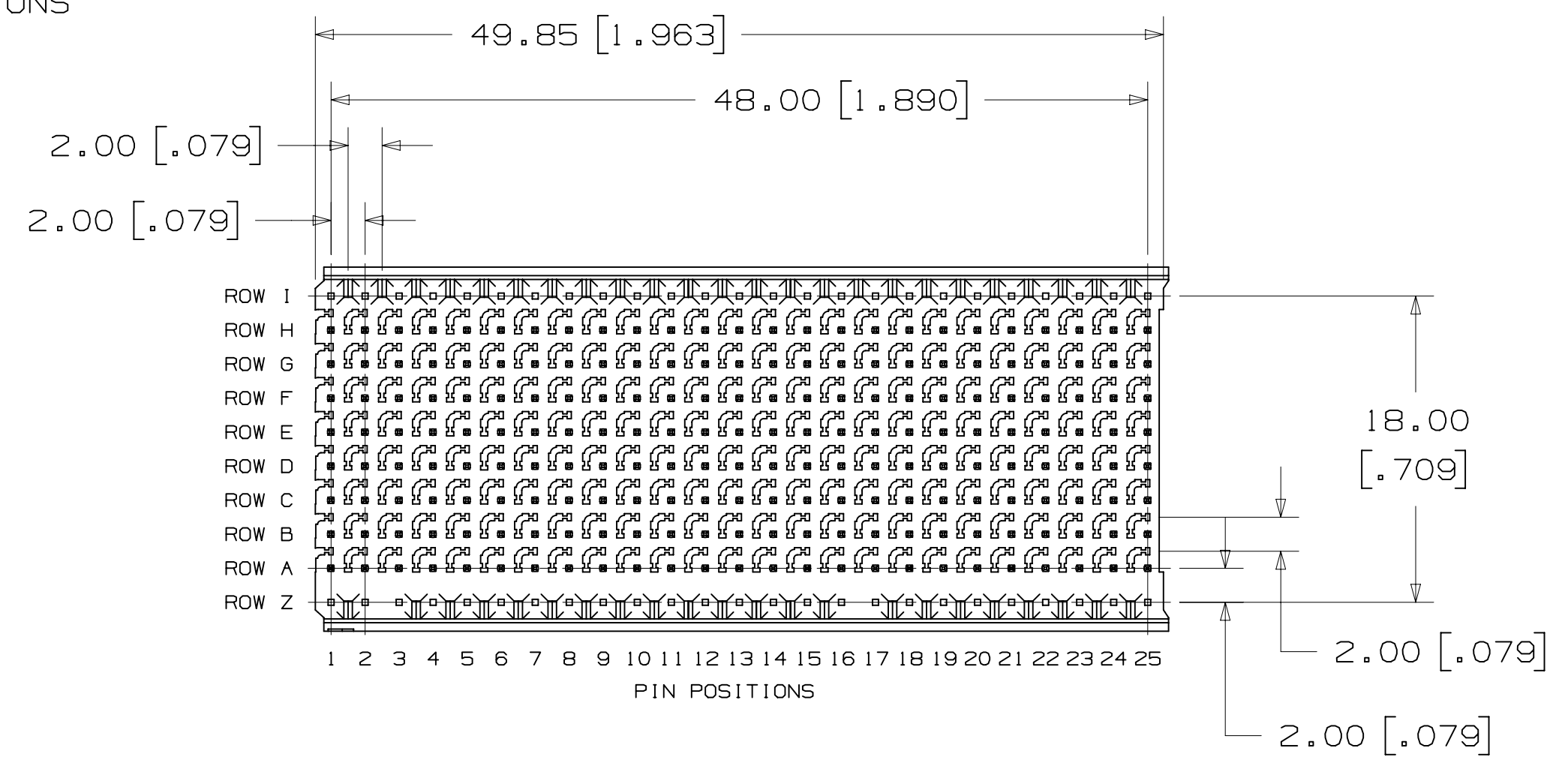

HM-H200E1-8CX1  
HM-H244E2-8BX1

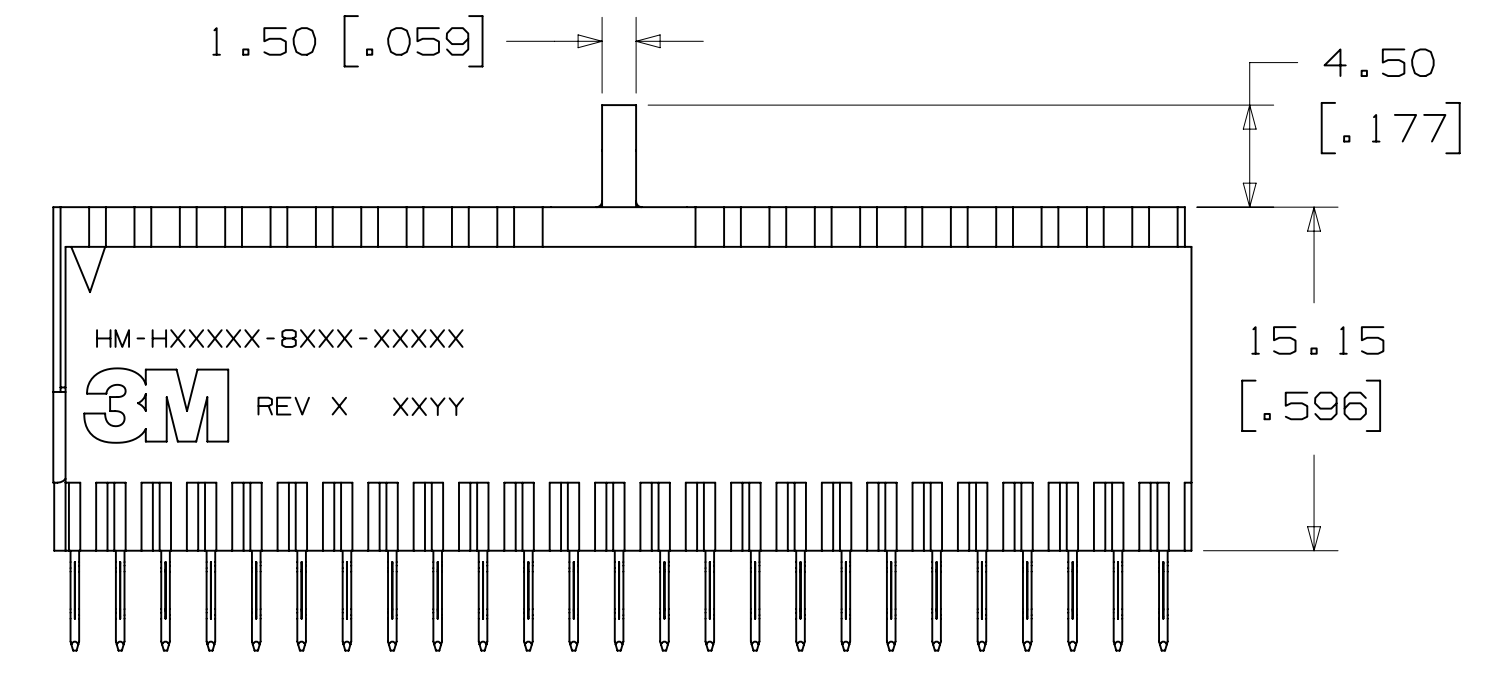
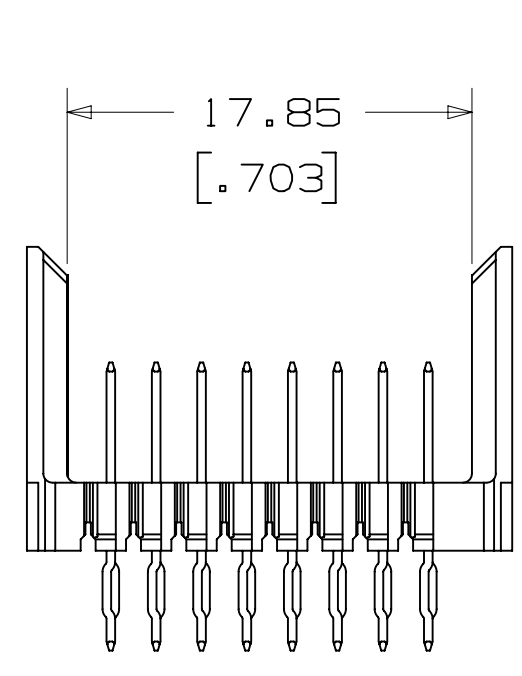

HM-H200DE1-8CX1  
HM-H244DE2-8BX1

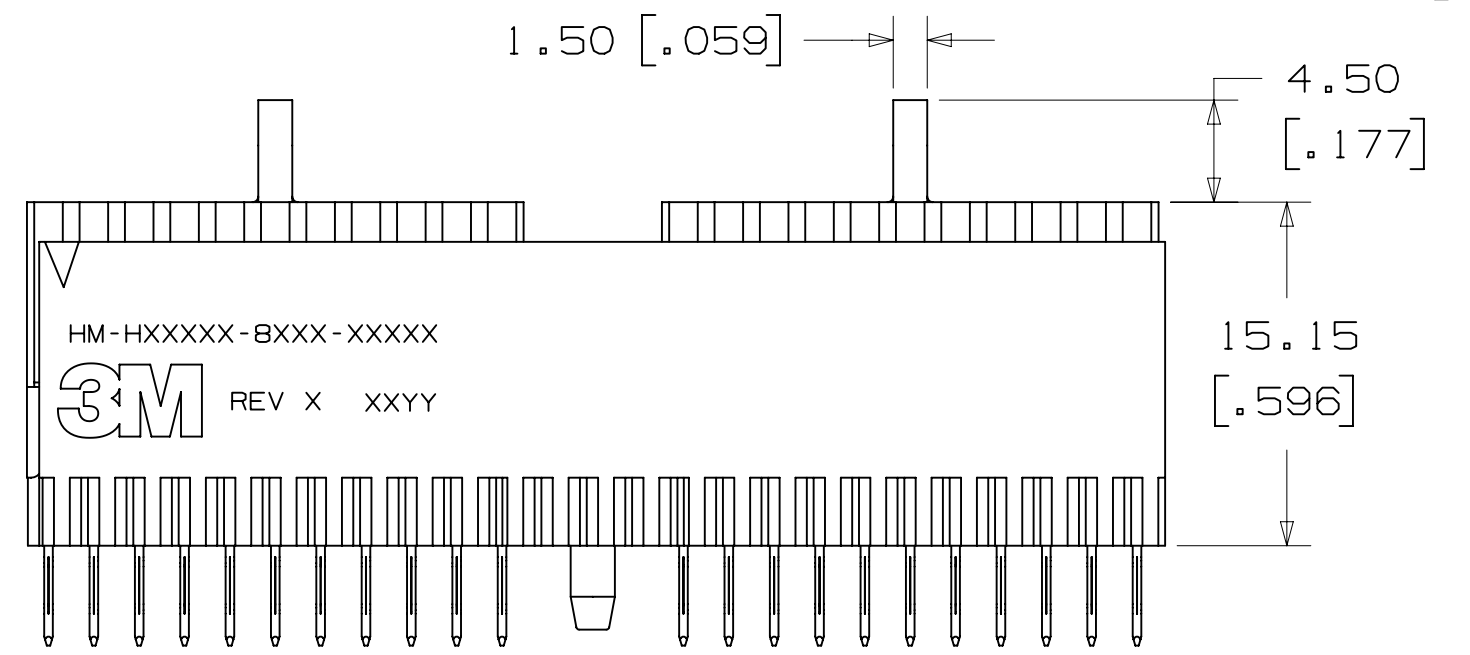
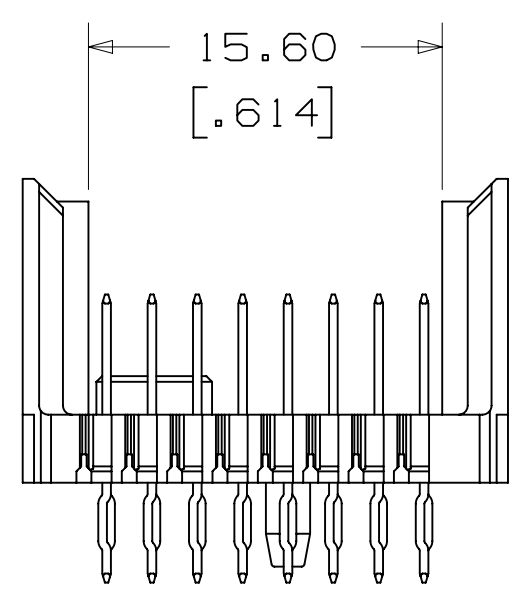
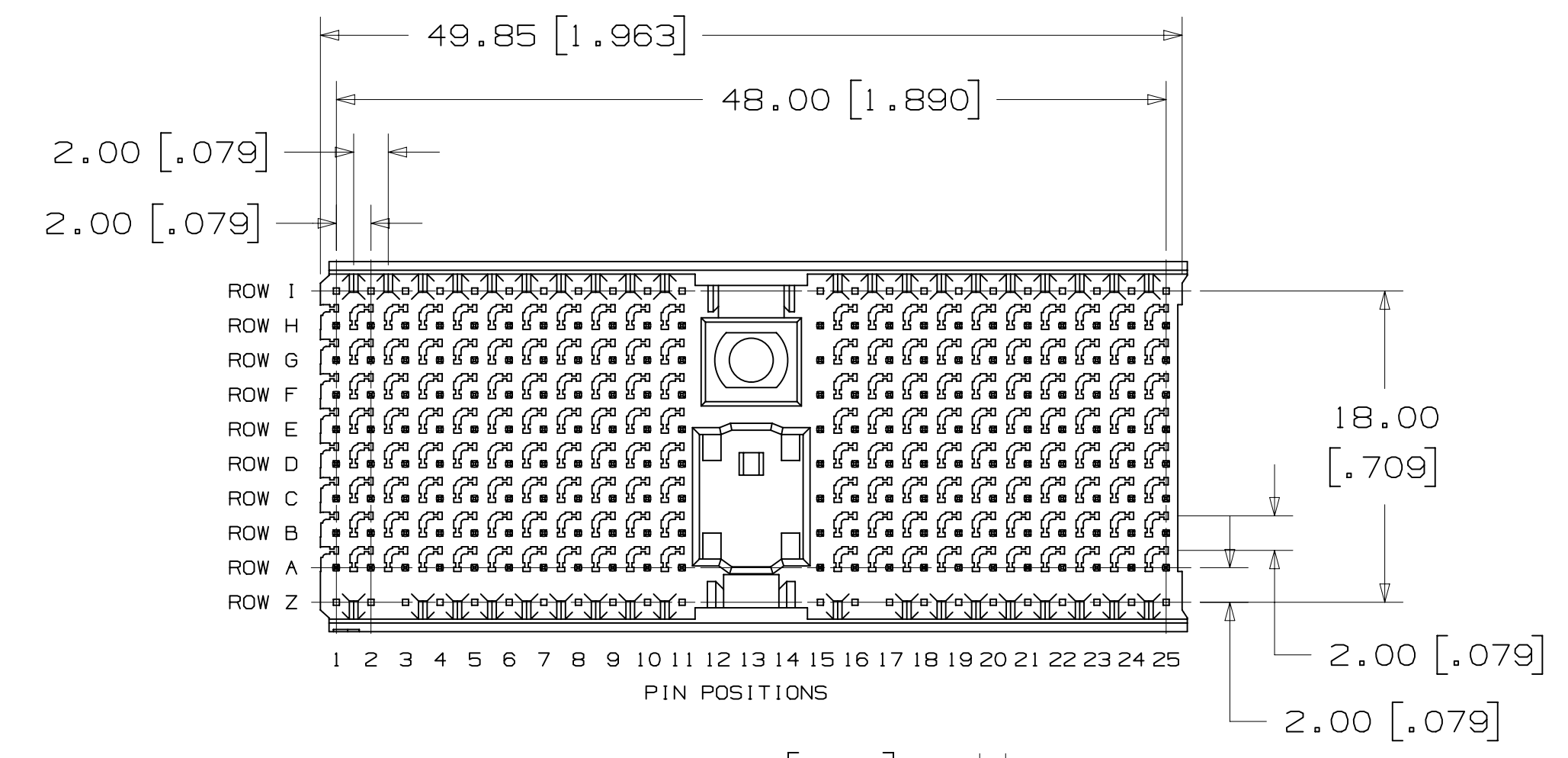

HM-H176D1-8CX1  
HM-H220D2-8BX1

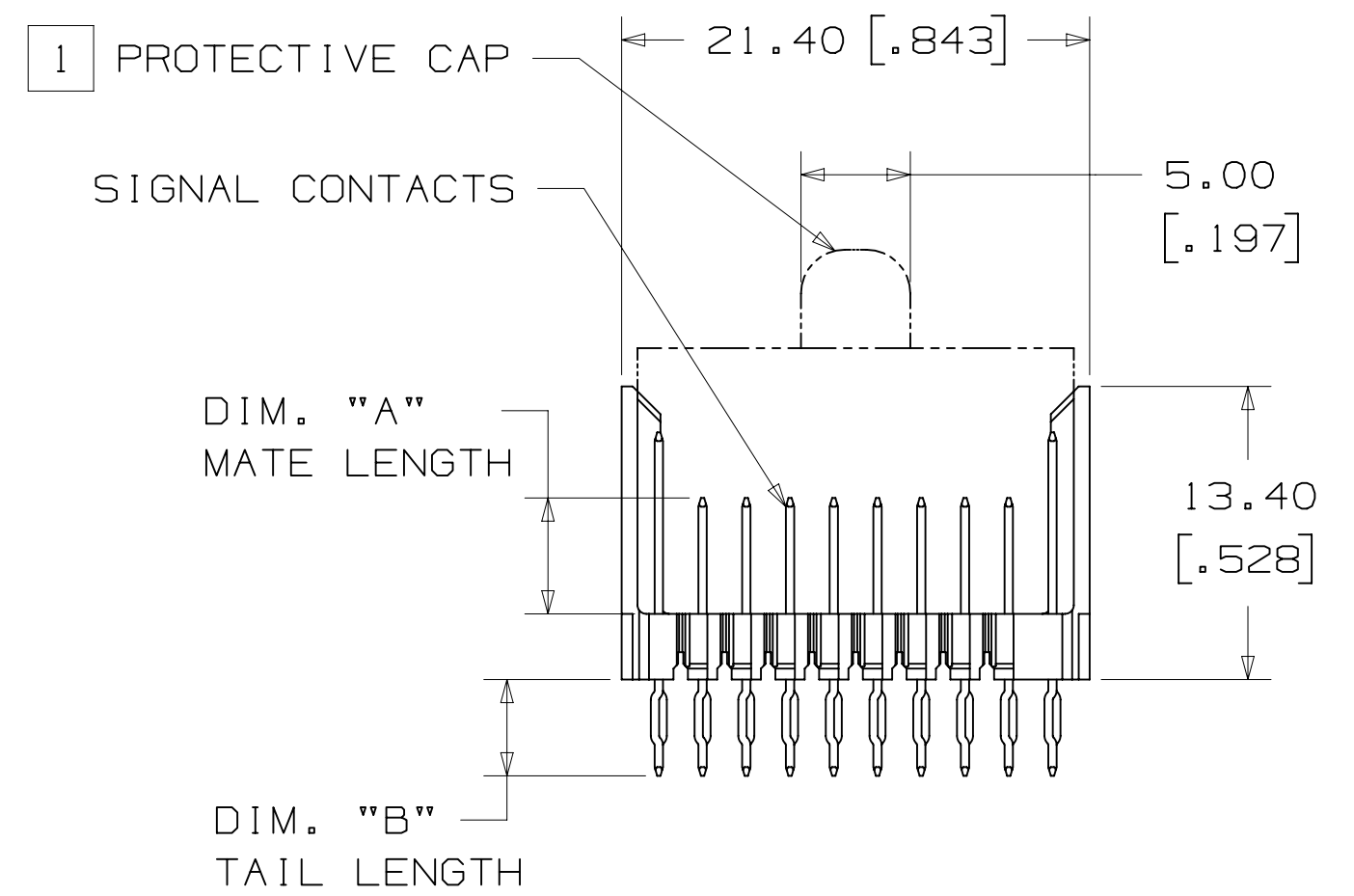

TYPICAL SIDE VIEW DIMENSIONS FOR THE HEADERS ON THIS DRAWING

STANDARD CONFIGURATION  
DIM. "A" 5.3 [.21] FOR ROWS A THRU H  
DIM. "B" 4.4 [.17] EXCEPT AS NOTED

FOR NON-STANDARD CONFIGURATIONS CONTACT A 3M SALES REPRESENTATIVE

DESIGN REFERENCE	NEXT ASSEMBLY	REV	ECO	ISSUE DATE AND DESCRIPTION	DRFT	CHKD
		A	39815	MAR 28, 2012 PRODUCTION RELEASE	JNC	TS
DIVISION		SCALE		TOLERANCES EXCEPT AS NOTED		
Interconnect Solutions		3/1		INCHES		
DO NOT SCALE DRAWING		INTERPRET PER ASME Y14.5 - 1994		MILLIMETERS		TITLE HM PRESS-FIT HEADER, 8-ROW, HM SERIES
THIRD ANGLE PROJECTION		MAX SURFACE ROUGHNESS		MILLIMETERS		
SURFACES MARKED ONLY		SURFACES		MILLIMETERS		CAGE NUMBER D 78-5100-2517-0
		SURFACES		MILLIMETERS		
		SURFACES		MILLIMETERS		MODEL SHT 2 OF 4
		SURFACES		MILLIMETERS		

78-5100-2517-0

3M™ HM PRESS-FIT HEADER, 8-ROW, HM SERIES  
FOR HARD METRIC APPLICATIONS

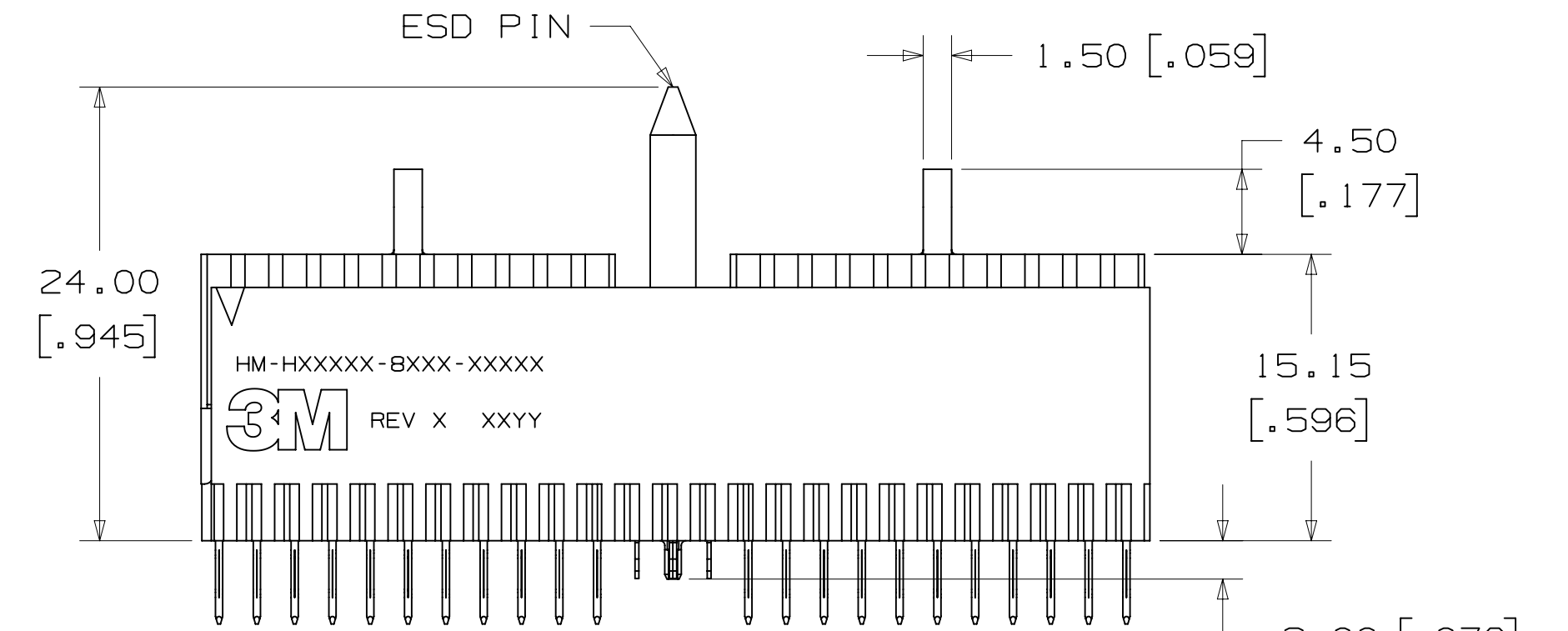
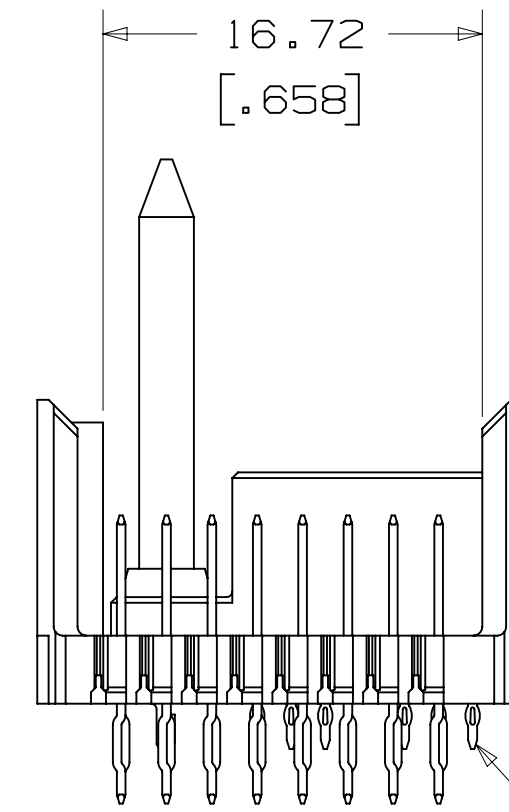
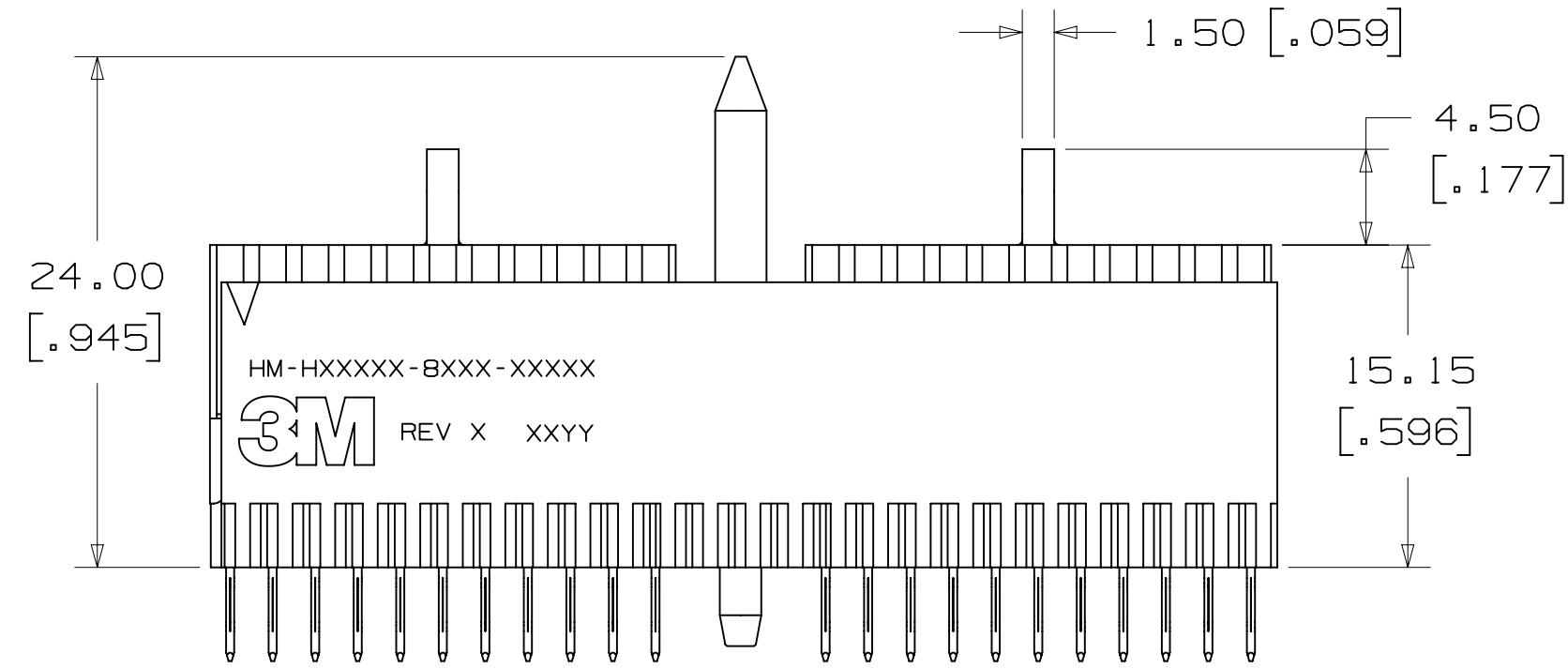
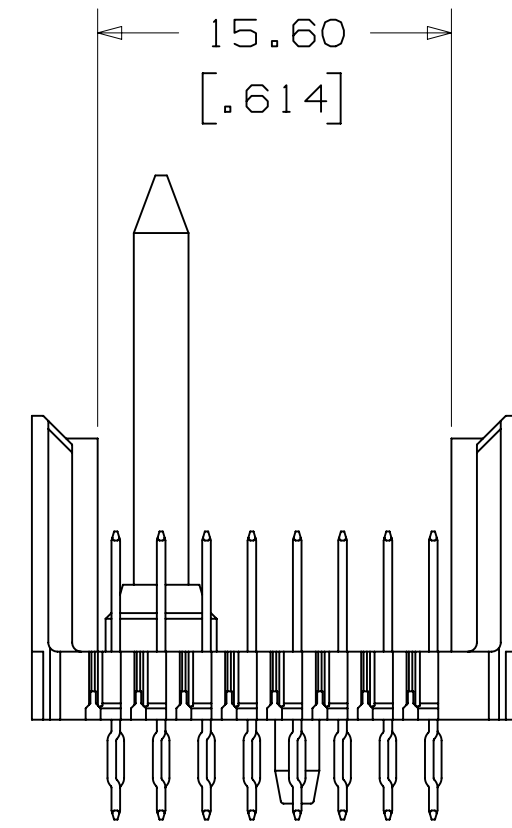
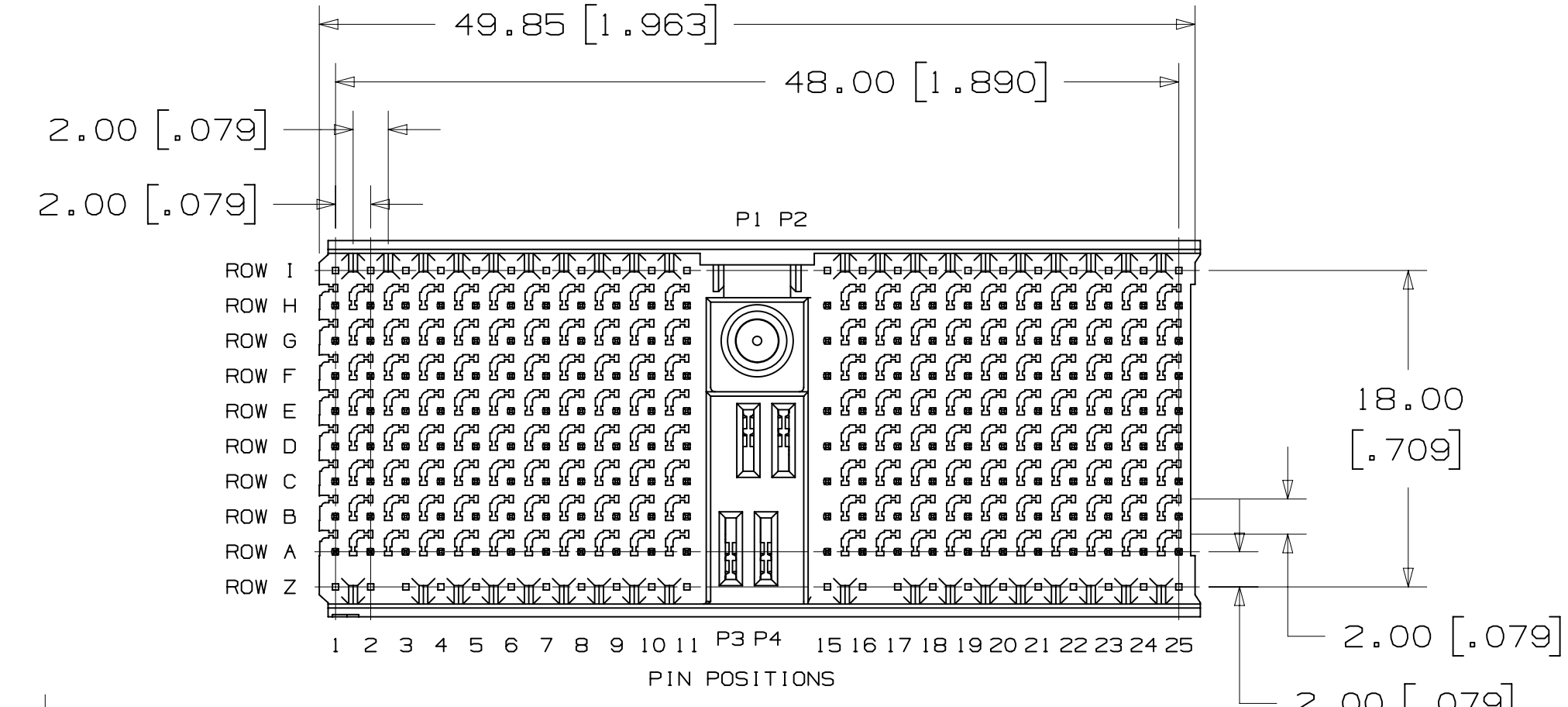
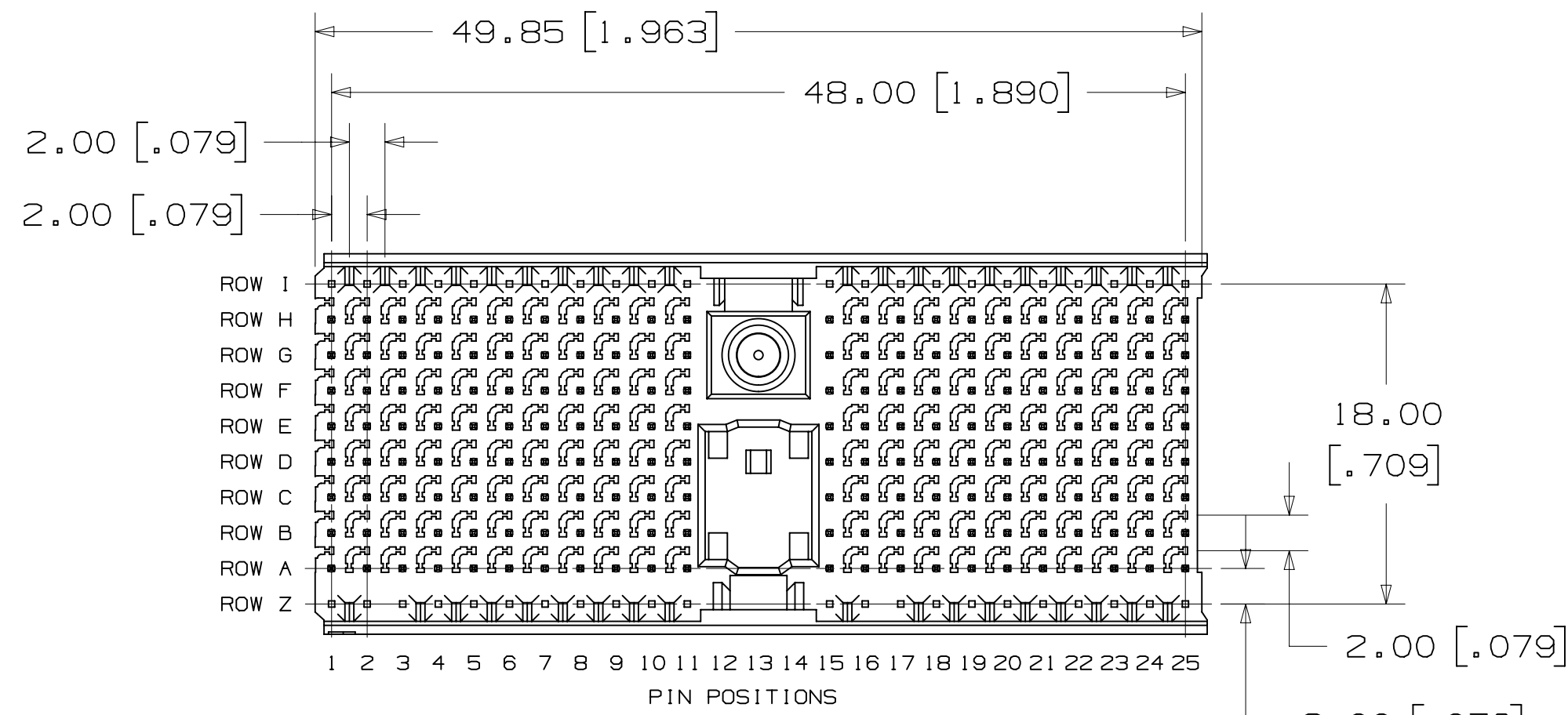

HM-H176DG1-8CX1  
HM-H220DG2-8BX1

POWER TAILS  
(4 CONTACTS,  
12 LEADS)

HM-H176DPWR1-8CXX  
HM-H220DPWR2-8BXX

ESD PIN TAIL  
LENGTH

DIM. "B" TAIL LENGTH  
1 = 4.4 [.17] PIN, 2.0 [.08] POWER  
AND 2.0 [.08] ESD  
2 = 4.4 [.17] PIN, 4.4 [.17] POWER  
AND 2.0 [.08] ESD

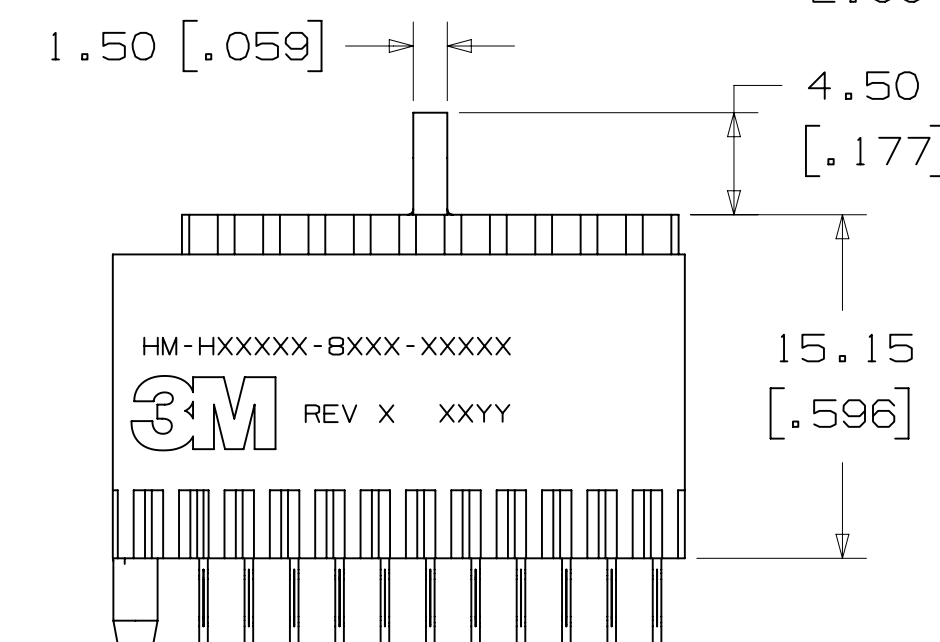
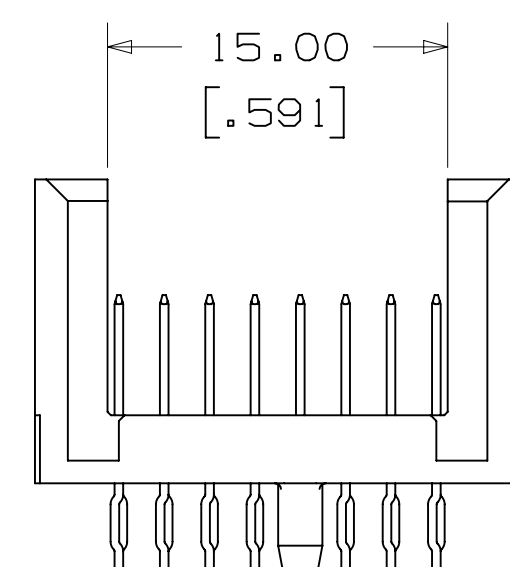
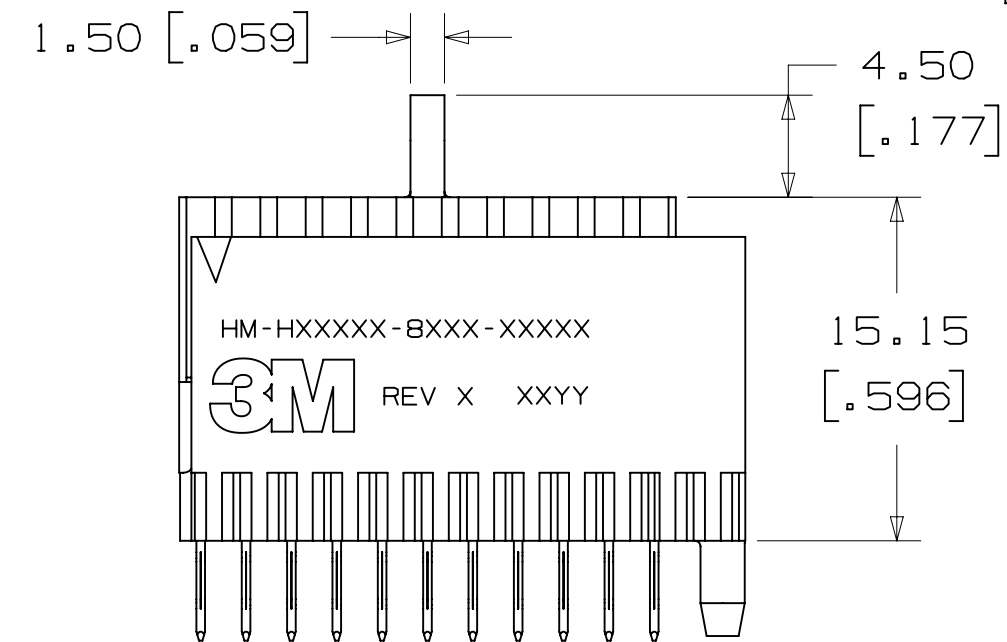
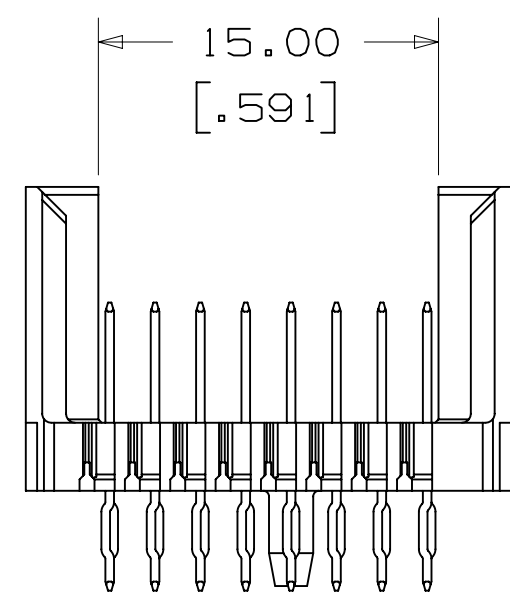
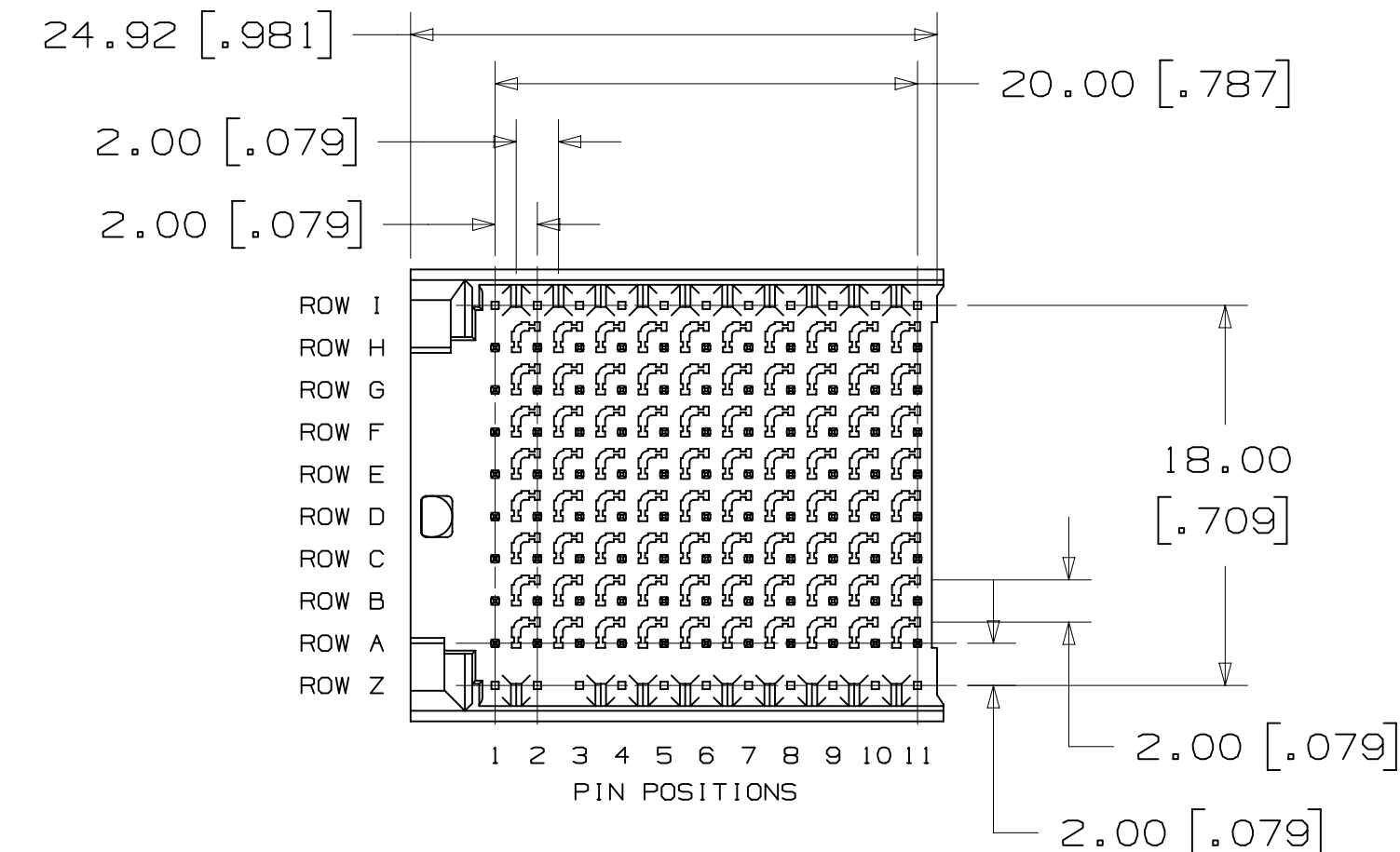
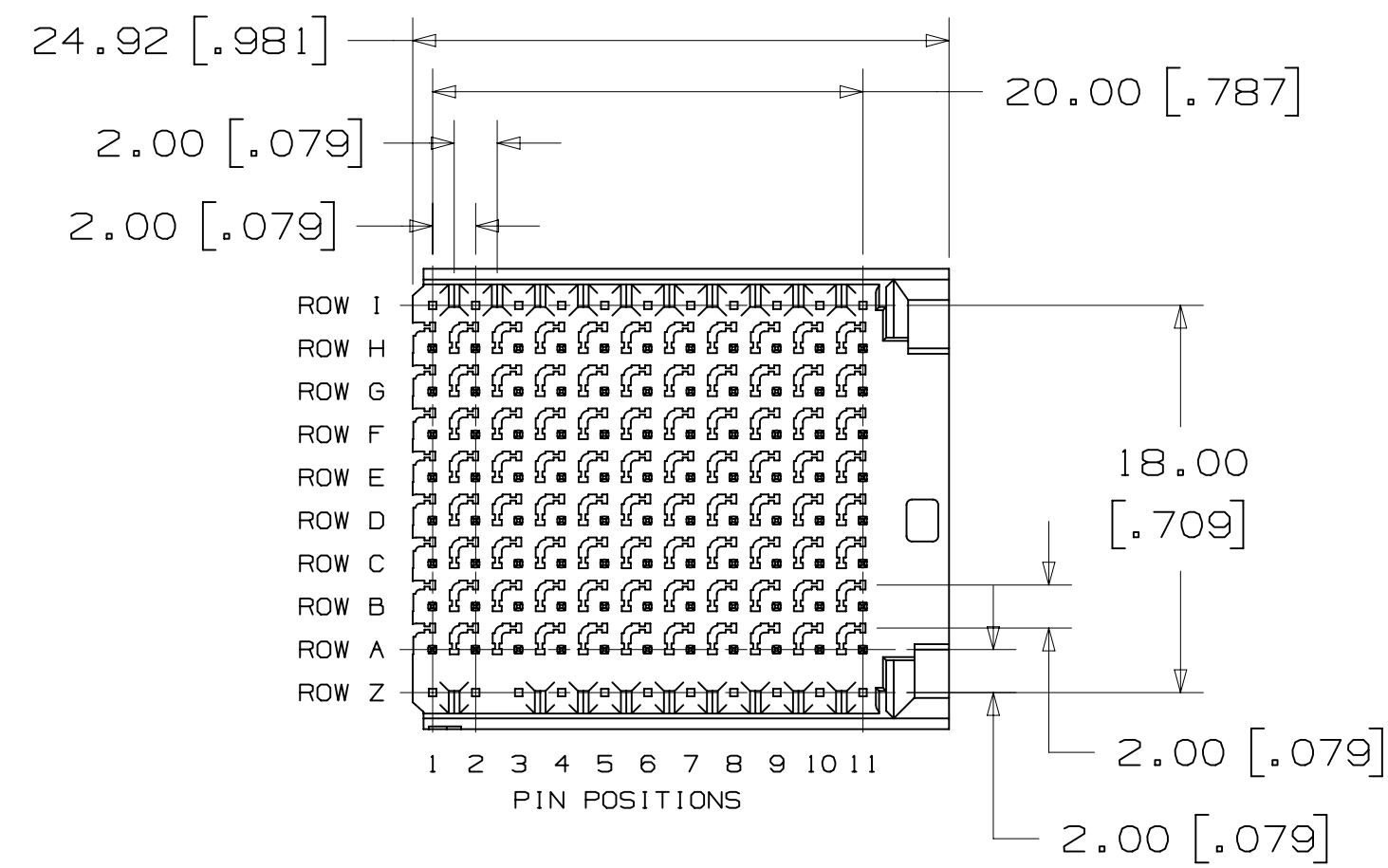

HM-H088FL1-8CX1  
HM-H110FL2-8BX1

HM-H088FR1-8CX1  
HM-H110FR2-8BXX1

DESIGN REFERENCE	NEXT ASSEMBLY	REV	ECO	ISSUE DATE AND DESCRIPTION	DRFT	CHKD
				MAR 28, 2012		
DIVISION		DIVISION CODE		DATE		
Interconnect Solutions		ISD		MAR 28, 2012		
DO NOT SCALE DRAWING		SCALE		TOLERANCES EXCEPT AS NOTED		
		3/1		INCHES		
				MILLIMETERS		
THIRD ANGLE PROJECTION				0 ±		
INTERPRET PER ASME Y14.5 - 1994				0 ± .3		
MAX SURFACE ROUGHNESS				0.00 ± .13		
SURFACES				.000 ±		
MARKED ONLY				ANGLES		
A 39815		MAR 28, 2012		JNC TS		
REV		ECO		ISSUE DATE AND DESCRIPTION		DRFT
				MAR 28, 2012		
DIP		DATE		MFG		DATE
CASTIGLIONE		MAR 28, 2012		T. SUNIGA		MAR 28, 2012
CHKD		DATE		APPR		DATE
3M		3M Center St. Paul, MN 55144		© 3M COPYRIGHT 2012		
TITLE		HM PRESS-FIT HEADER, 8-ROW, HM SERIES				
CAGE NUMBER		SIZE		DRAWING NO.		REV.
D78-5100-2517-0		A		D78-5100-2517-0		A
MODEL		SHT		3 OF 4		

3M™ HM PRESS-FIT HEADER, 8-ROW, HM SERIES  
FOR HARD METRIC APPLICATIONS

HOLE	HOLE PLATING TABLE			
	(FINISHED HOLE)	Cu THICKNESS	SnPb THICKNESS	DRILLED HOLE DIA.
DIM. "B"	.690-.790 [.0270-.0310]	.025-.045 [.0010-.0018]	.008-.018 [.0003-.0007]	.810-.860 [.0320-.0340]
DIM. "D"	.550-.650 [.0217-.0256]	.025-.045 [.0010-.0018]	.008-.018 [.0003-.0007]	.686-.727 [.0270-.0286]

1 ROW 1 AND Z HOLES ARE ONLY USED FOR HM-HXXXX2-8BX1 STYLE HEADER.

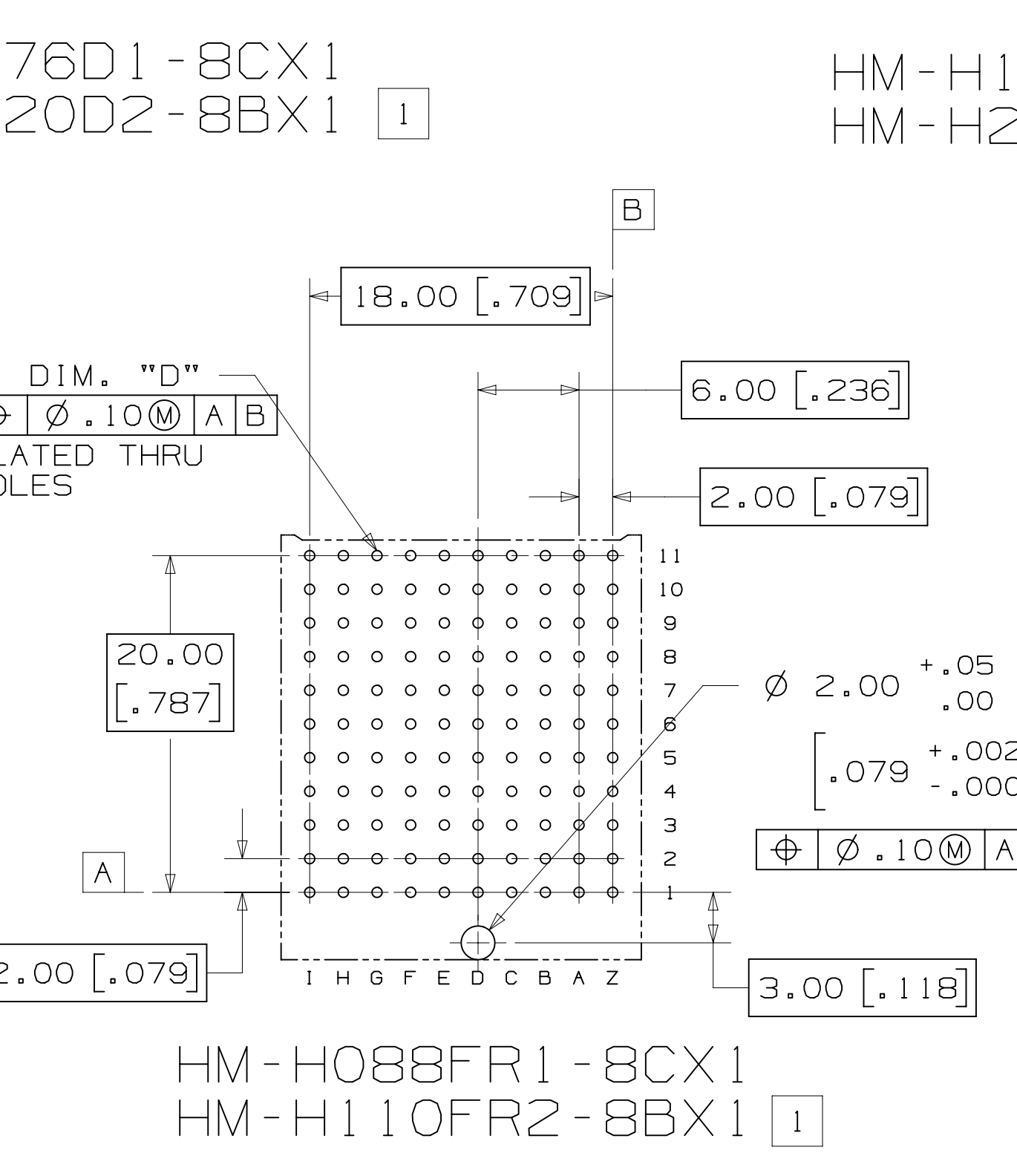
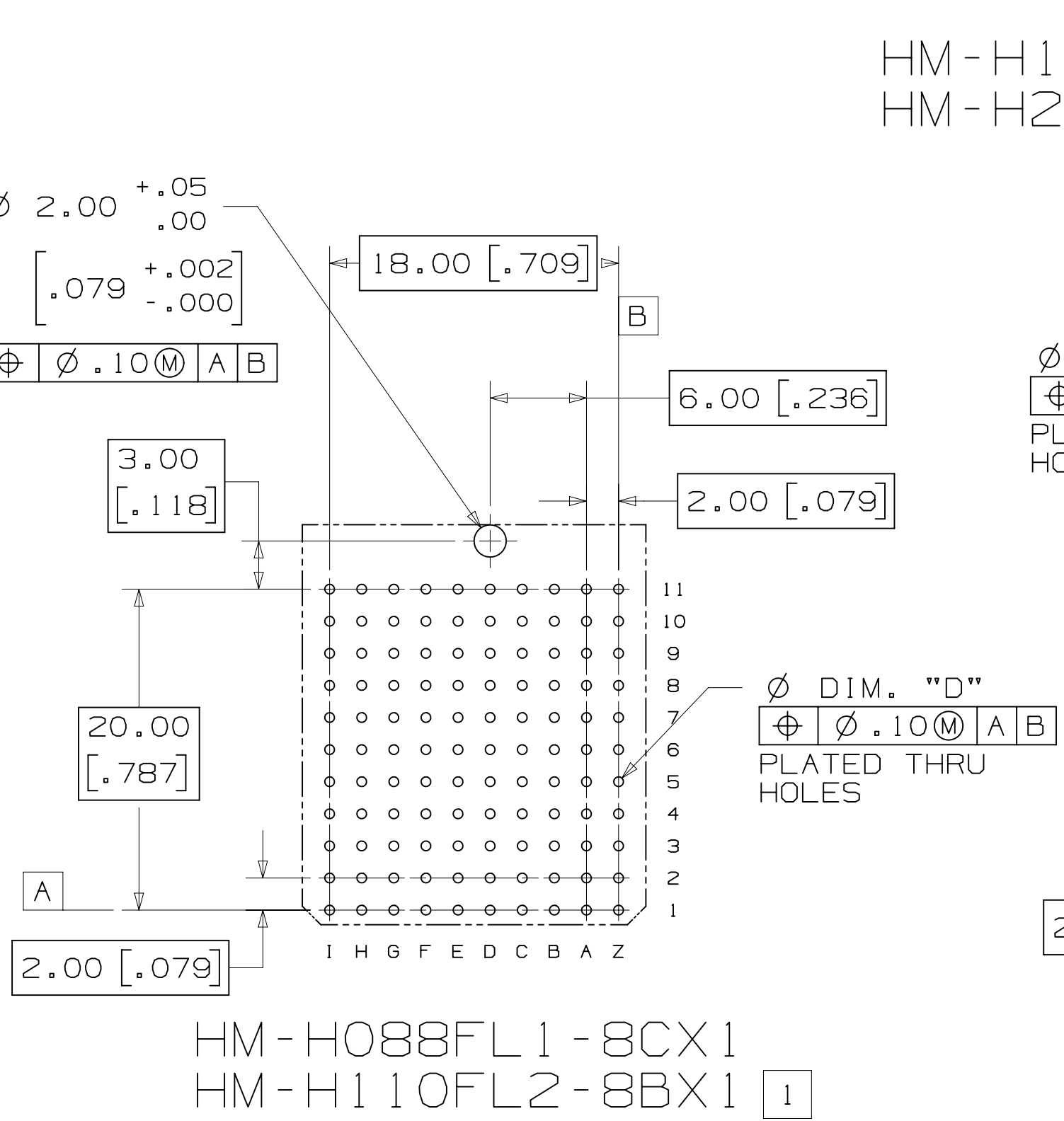
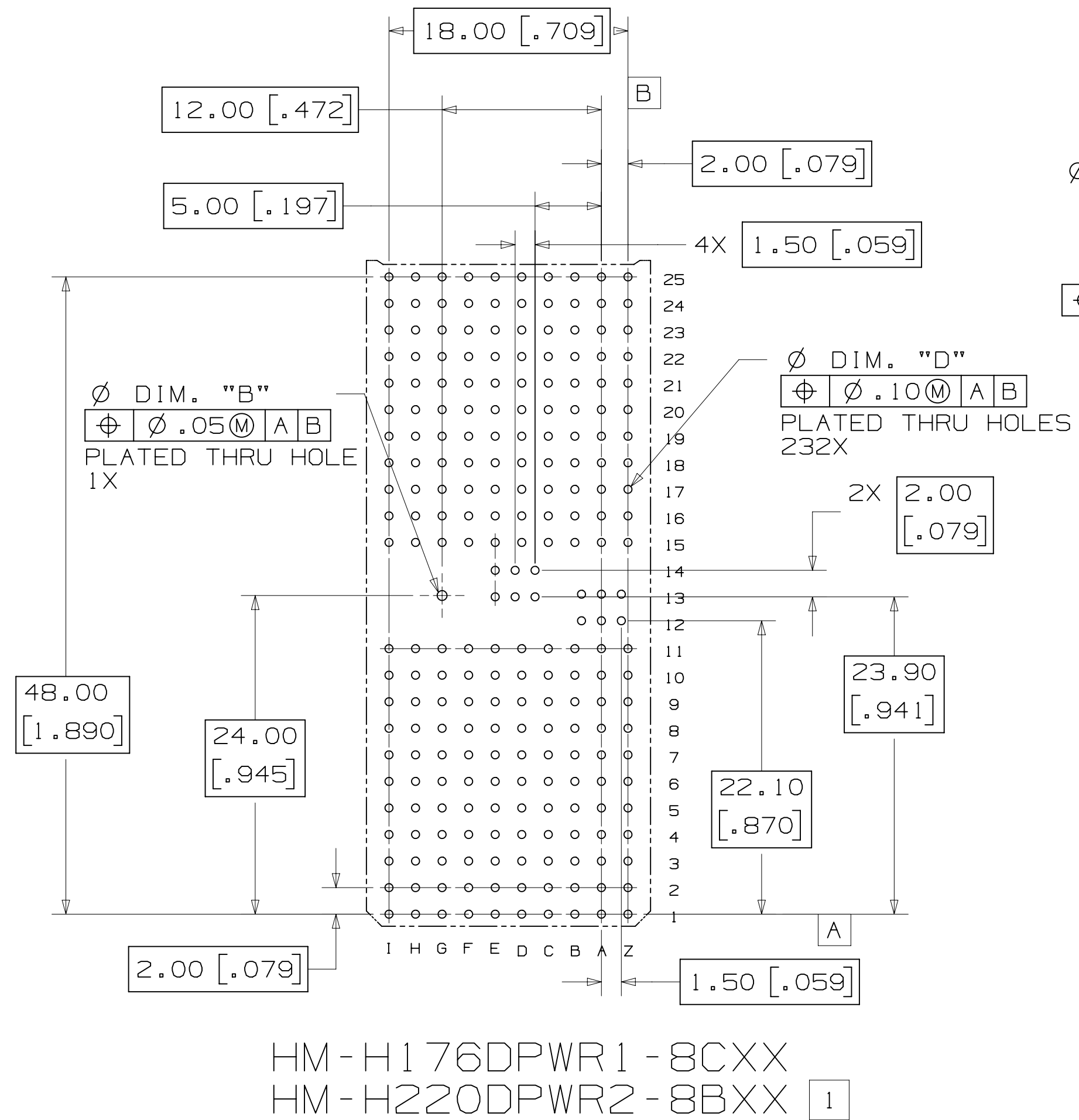
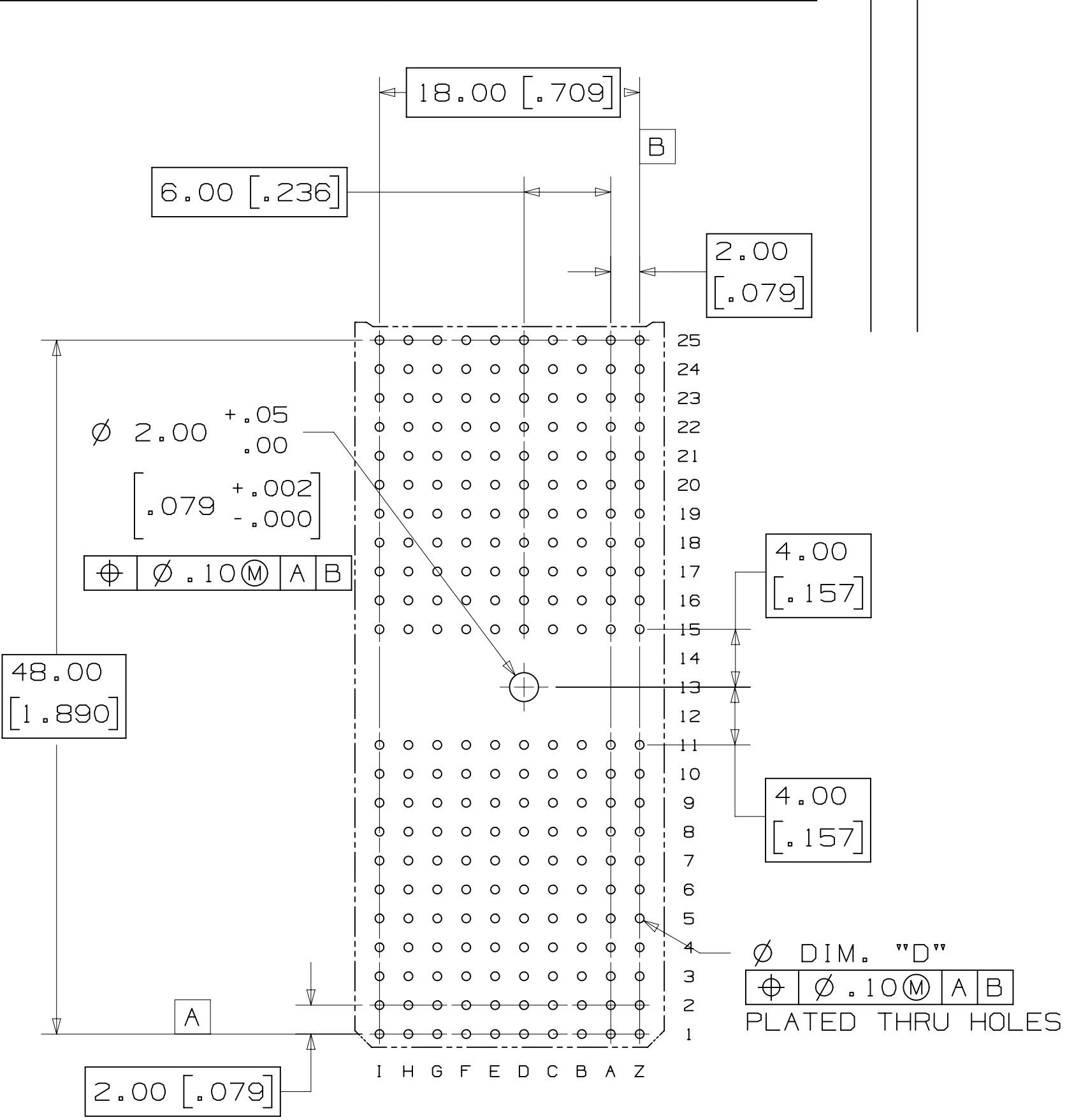
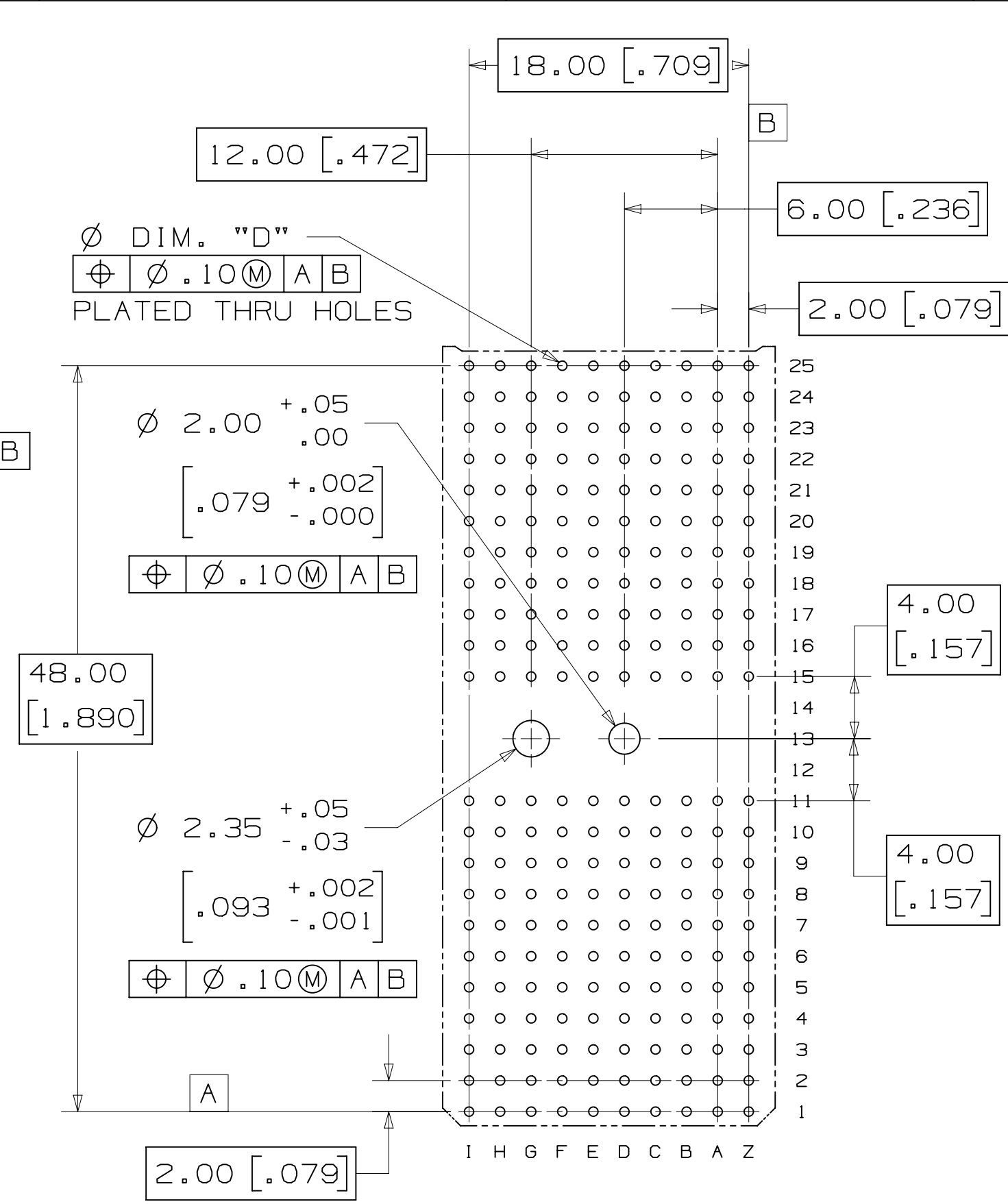
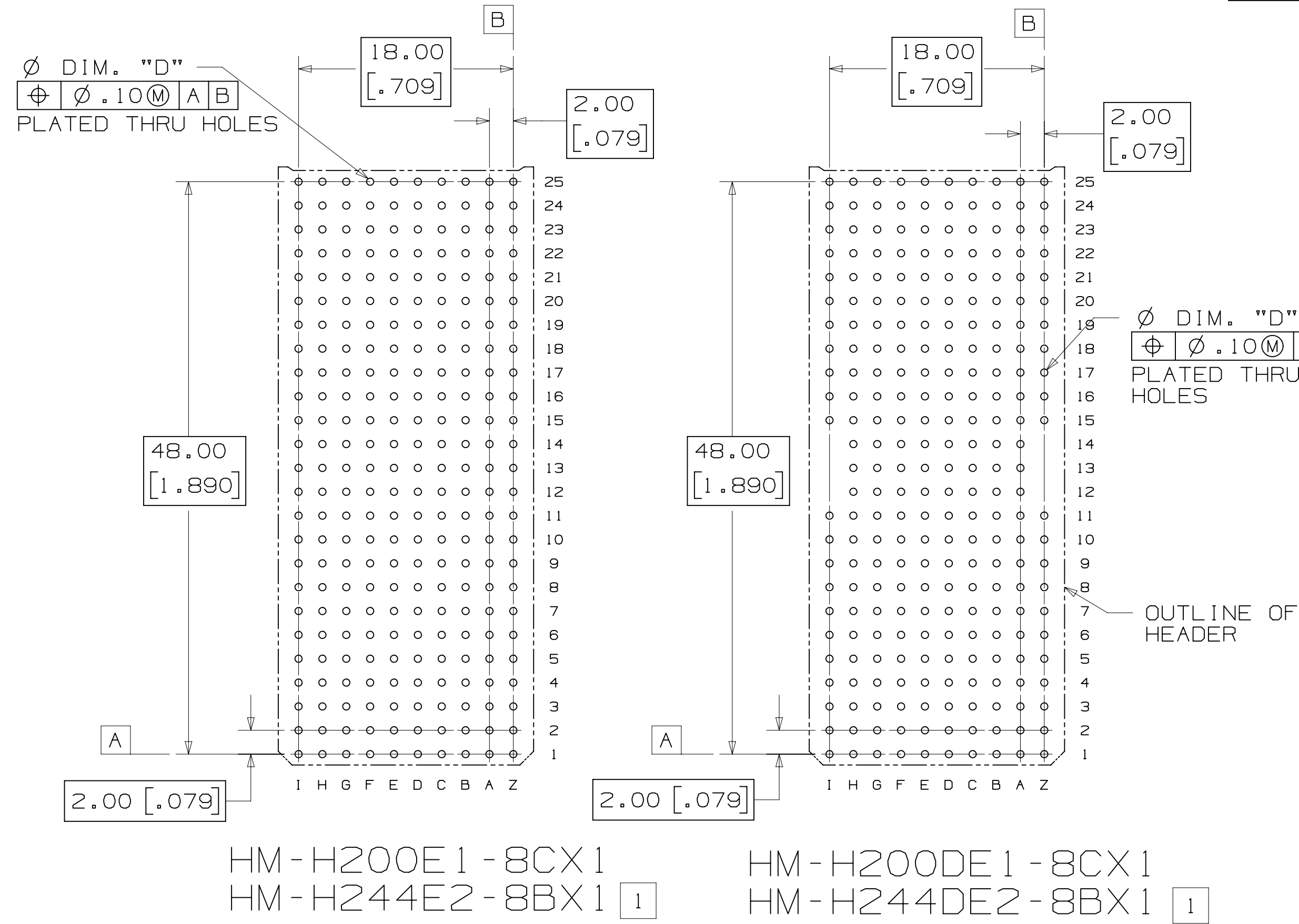

RECOMMENDED PCB MOUNTING HOLE PATTERN  
(VIEWED FROM COMPONENT SIDE)

DESIGN REFERENCE	NEXT ASSEMBLY	REV	ECO	ISSUE DATE AND DESCRIPTION	DRFT	CHKD
		A	39815	MAR 28, 2012	JNC	TS
				PRODUCTION RELEASE		
DATE	DATE	DATE	DATE	DATE	DATE	DATE
CASTIGLIONE	MAR 28, 2012	MFG				
		APPR	T. SUNIGA			
		DATE		MAR 28, 2012		
DIVISION	DIVISION CODE	© 3M COPYRIGHT 2012				
Interconnect Solutions	ISD	This document and the information it contains are 3M property and may not be reproduced or further distributed without 3M permission, or used or disclosed other than for 3M authorized purposes. All rights reserved.				
DO NOT SCALE DRAWING	SCALE 3/1	TOLERANCES EXCEPT AS NOTED	3M			
		INCHES	St. Paul, MN 55144			
		.00 ± .01	TITLE			
		.000 ± .005	HM PRESS-FIT HEADER, 8-ROW, HM SERIES			
		.0000 ±	CAGE NUMBER			
THIRD ANGLE PROJECTION	INTERPRET PER ASME Y14.5 - 1994	MILLIMETERS	D 78-5100-2517-0			
		0	DRAWING NO.			
		.0 ± .3	REV.			
		.00 ± .13	A			
		.000 ±	MODEL			
		ANGLES	SHT 4 OF 4			

78-5100-2517-0

## Данный компонент на территории Российской Федерации

### Вы можете приобрести в компании MosChip.

Для оперативного оформления запроса Вам необходимо перейти по данной ссылке:

<http://moschip.ru/get-element>

Вы можете разместить у нас заказ для любого Вашего проекта, будь то серийное производство или разработка единичного прибора.

В нашем ассортименте представлены ведущие мировые производители активных и пассивных электронных компонентов.

Нашей специализацией является поставка электронной компонентной базы двойного назначения, продукции таких производителей как XILINX, Intel (ex.ALTERA), Vicor, Microchip, Texas Instruments, Analog Devices, Mini-Circuits, Amphenol, Glenair.

Сотрудничество с глобальными дистрибьюторами электронных компонентов, предоставляет возможность заказывать и получать с международных складов практически любой перечень компонентов в оптимальные для Вас сроки.

На всех этапах разработки и производства наши партнеры могут получить квалифицированную поддержку опытных инженеров.

Система менеджмента качества компании отвечает требованиям в соответствии с ГОСТ Р ИСО 9001, ГОСТ РВ 0015-002 и ЭС РД 009

### Офис по работе с юридическими лицами:

105318, г.Москва, ул.Щербаковская д.3, офис 1107, 1118, ДЦ «Щербаковский»

Телефон: +7 495 668-12-70 (многоканальный)

Факс: +7 495 668-12-70 (доб.304)

E-mail: [info@moschip.ru](mailto:info@moschip.ru)

Skype отдела продаж:

moschip.ru

moschip.ru\_4

moschip.ru\_6

moschip.ru\_9