

3M™ HM PRESS-FIT HEADER, 8-ROW, HM SERIES
FOR HARD METRIC APPLICATIONS

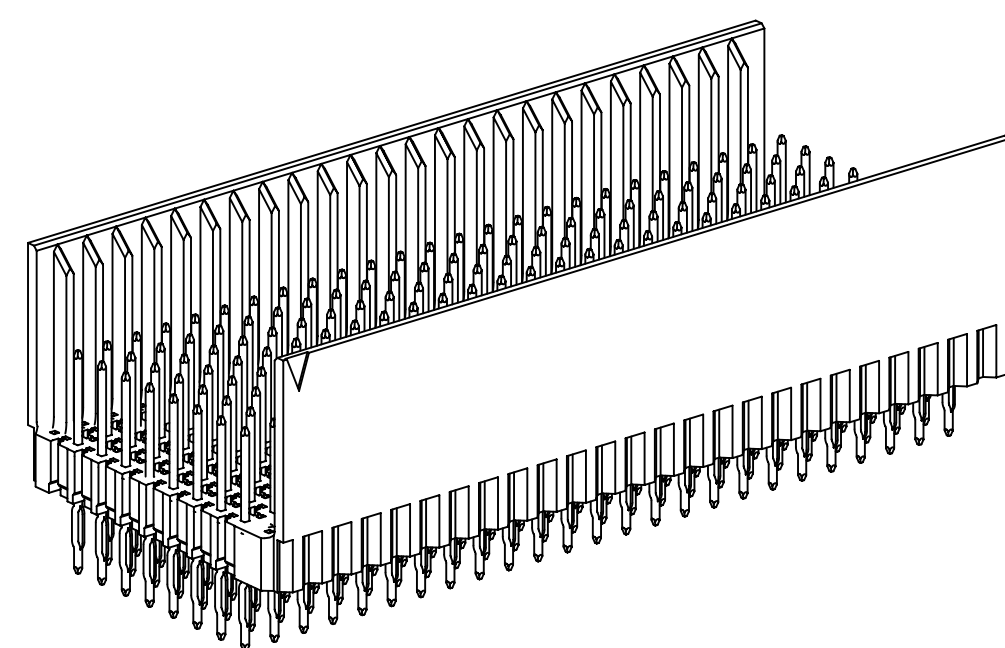

HM-H200E1-8CX1
HM-H244E2-8BX1

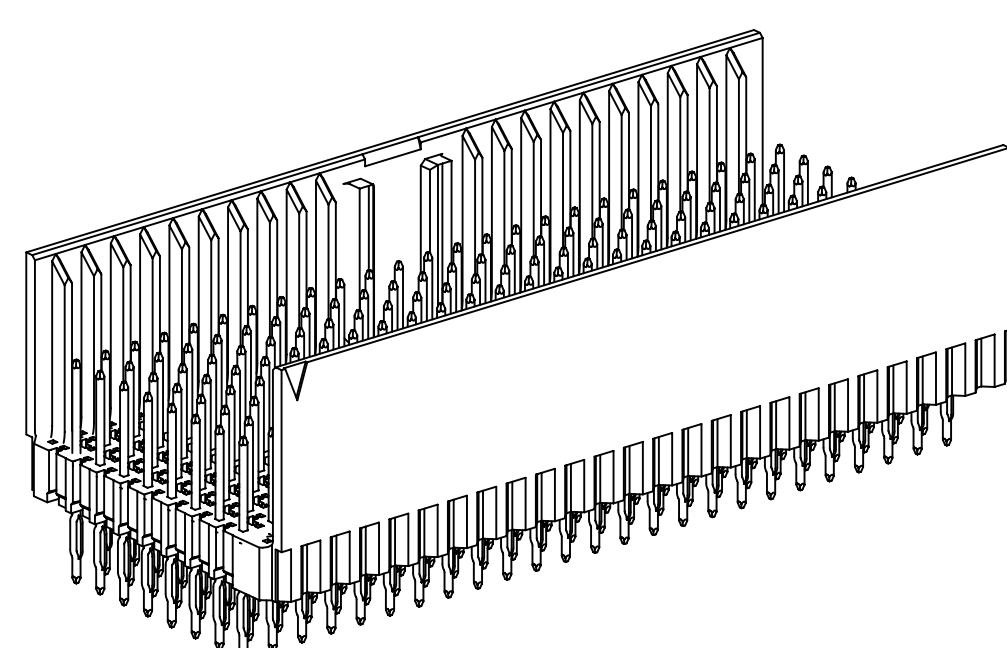

HM-H200DE1-8CX1
HM-H244DE2-8BX1

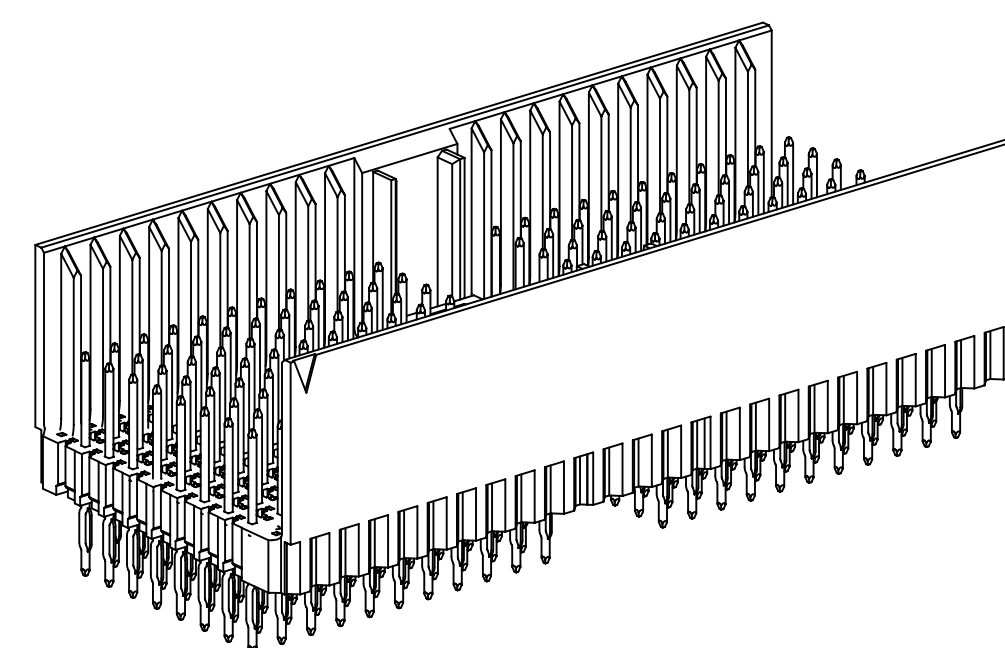

HM-H176D1-8CX1
HM-H220D2-8BX1

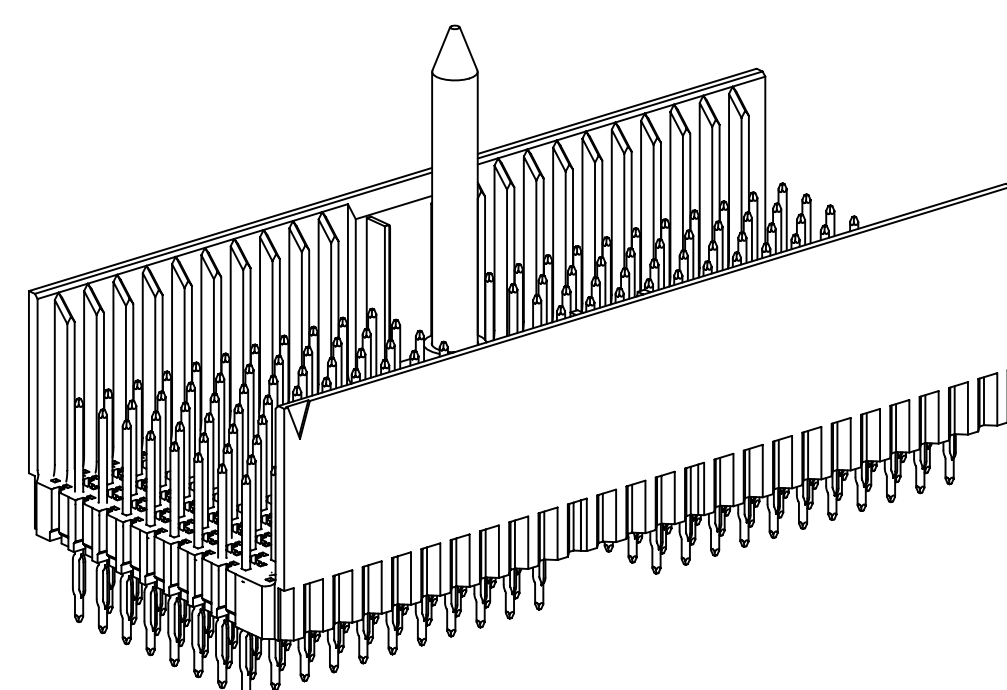

HM-H176DG1-8CX1
HM-H220DG2-8BX1

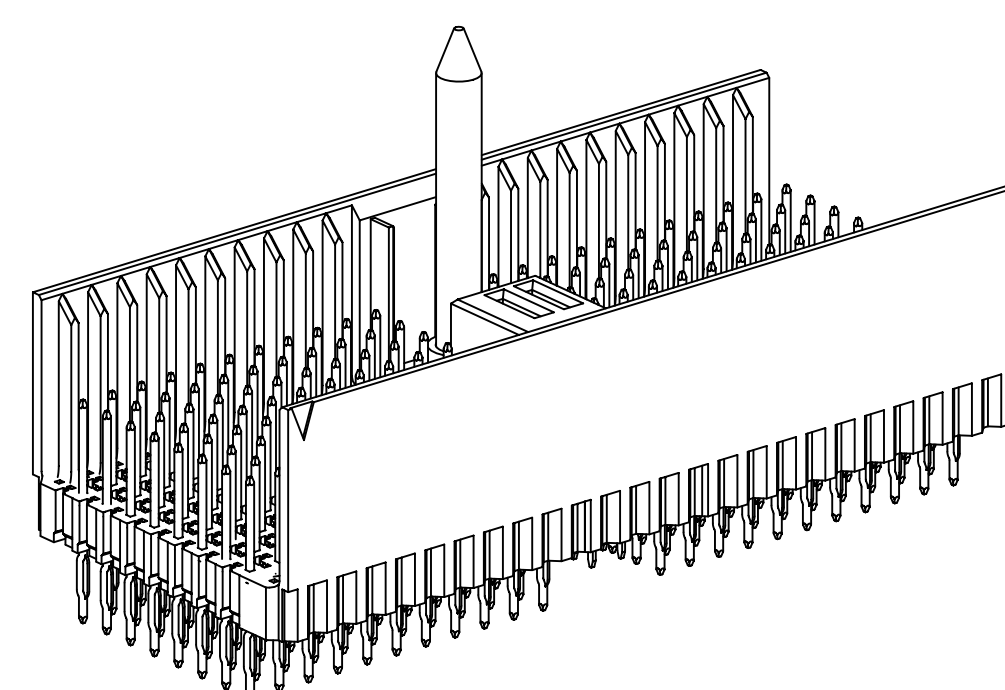

HM-H176DPWR1-8CX1
HM-H220DPWR2-8BX1

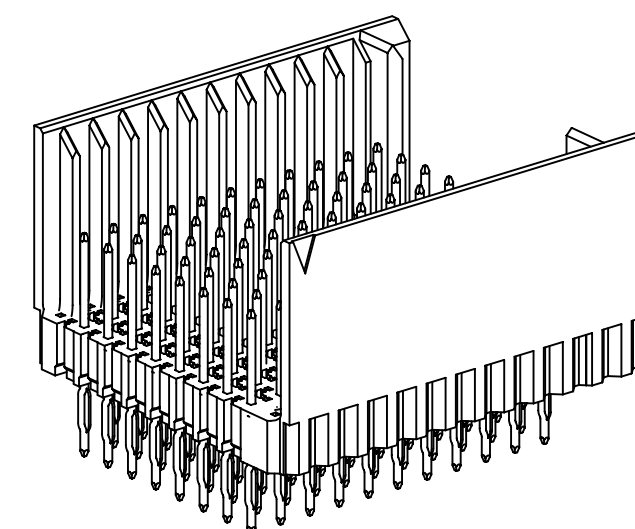

HM-H088FL1-8CX1
HM-H110FL2-8BX1

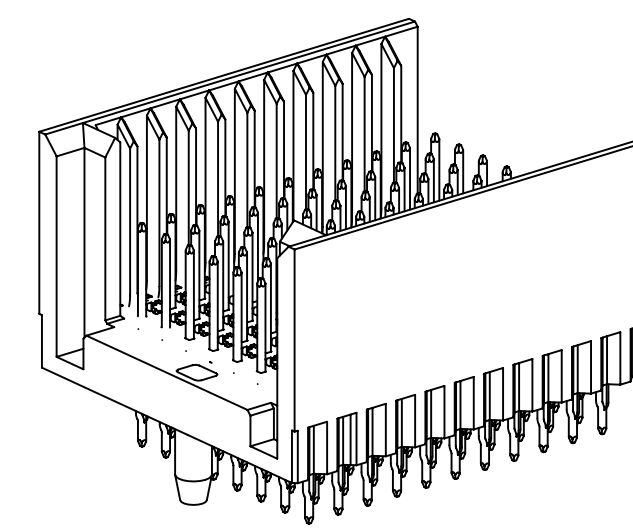

HM-H088FR1-8CX1
HM-H110FR2-8BX1

(UNLESS OTHERWISE SHOWN)
ORDERING INFORMATION
(ROWS I AND Z NOT LOADED)

HM-HXXXXX1-8CX1-XXXXX

HEADER POSITION AND TYPE

TAIL STYLE:
P = PRESS-FIT TAIL
S = SOLDER TAIL

PLATING

(UNLESS OTHERWISE SHOWN)
ORDERING INFORMATION
(ROWS I AND Z LOADED, 8.3MM MATE LENGTH)

HM-HXXXXX2-8BX1-XXXXX

HEADER POSITION AND TYPE

TAIL STYLE:
P = PRESS-FIT TAIL
S = SOLDER TAIL

PLATING

PLATING SPECIFICATIONS:

TG30L = .76µM [30µIN] MIN. GOLD ON CONTACT AREA, LUBRICATED
2.54µM [100µIN] MIN. TIN/LEAD ON TERMINAL AREA (RIA C2 & E2 APPLY)
1.27µM [50µIN] MIN. NICKEL ALL OVER.
TYPICALLY HIGHER MAKE ORDER QUANTITIES AS COMPARED TO TG30.

TG30 = .76µM [30µIN] MIN. GOLD ON CONTACT AREA
2.54µM [100µIN] MIN. TIN/LEAD ON TERMINAL AREA (RIA C2 & E2 APPLY)
1.27µM [50µIN] MIN. NICKEL ALL OVER.
STANDARD OPTION.

TG50 = 1.27µM [50µIN] MIN. GOLD ON CONTACT AREA, LUBRICATED
2.54µM [100µIN] MIN. TIN/LEAD ON TERMINAL AREA (RIA C2 & E2 APPLY)
1.27µM [50µIN] MIN. NICKEL ALL OVER.
NON-STANDARD OPTION (AVAILABLE WITH LONGER LEAD TIMES AND HIGHER MAKE ORDER QUANTITIES, MOQ)

KR = .76µM [30µIN] MIN. GOLD ON CONTACT AREA
2.54µM [100µIN] MIN. MATTE TIN ON TERMINAL AREA (RIA C2 & E2 APPLY)
1.27µM [50µIN] MIN. NICKEL ALL OVER.

- * MODULAR/SCALABLE FORMAT IEC 61076-4-101
- * PRESS-FIT OF SOLDER TAIL VERSION
- * 101 MATED LINES PER INCH
- * SHIPS WITH PROTECTIVE CAP, WHICH ALSO SERVES AS AN INSERTION TOOL
- * END-TO-END STACKABLE WITH 8 ROW 3M™ HM AND HSHM PRODUCTS
- * INTEGRATED GUIDE AND GUIDE PIN
- * MULTI-PURPOSE CENTER (MPC) KEYING AND GUIDANCE
- * FOUR INTEGRATED 8.25 A POWER CONTACTS AND GUIDE PIN

- NOTES
- MATERIAL:
PLASTIC: HIGH TEMP LCP, UL94V-0
PINS: COPPER ALLOY.
 - REGULATORY INFORMATION:
ROHS COMPLIANT. SEE THE REGULATORY INFORMATION APPENDIX (RIA) IN THE "ROHS COMPLIANCE" SECTION OF WWW.3MCONNECTORS.COM FOR COMPLIANCE INFORMATION (RIA E1 & C1 APPLY)
 - IN THE EVENT OF CONFLICT BETWEEN THIS DATA AND THAT CONTAINED IN THE PRODUCT SPECIFICATION, THE PRODUCT SPECIFICATION TAKES PRECEDENT.

MECHANICAL:

NORMAL FORCE (NOMINAL): .57N [58g] SIGNAL
ENGAGEMENT FORCE (NOMINAL): .32N [33g] SIGNAL
SEPARATION FORCE (NOMINAL): .20N [20g] SIGNAL
WIPE (NOMINAL, SHORTEST CONTACT): 2.67 [.105] SIGNAL
MATE/UNMATE CYCLES: 250
APPLICATION: THIS MODULE IS NOT SUITABLE FOR STAND-ALONE USE. (REFER TO IEC-61076-4-101)

ELECTRICAL:

CURRENT RATING (FULLY LOADED): 1A @ 70°C SIGNAL
INSULATION RESISTANCE: 1 X 10⁴ MΩ @ 100 V_{DC}
WITHSTANDING VOLTAGE: 750V_{RMS}

ENVIRONMENTAL:

TEMPERATURE RATING: -55°C TO 125°C
PROCESS RATING: MAX. 260°C (PER J-STD-020C)
WITHSTANDING VOLTAGE: 1 (PER J-STD-020C)

3M™ ELECTRONIC SOLUTIONS DIVISION
INTERCONNECT SOLUTIONS
<http://www.3mconnectors.com>

3M IS A TRADEMARK OF 3M COMPANY.
FOR TECHNICAL, SALES OR ORDERING INFORMATION CALL 800-225-5373

CAUS
UL FILE NO: E68080

DESIGN REFERENCE		NEXT ASSEMBLY	REV	ECO	ISSUE DATE AND DESCRIPTION	DRFT	CHKD
A 39815					MAR 28, 2012	JNC	TS
DIVISION		DIVISION CODE	DATE		DATE		
Interconnect Solutions		ISD	MAR 28, 2012		MAR 28, 2012		
DO NOT SCALE DRAWING		SCALE	TOLERANCES EXCEPT AS NOTED				
THIRD ANGLE PROJECTION		INCHES	MILLIMETERS		TITLE HM PRESS-FIT HEADER, 8-ROW, HM SERIES		
INTERPRET PER ASME Y14.5 - 1994		.00 ± .01 .000 ± .005 .0000 ±	.0 ± .3 .00 ± .13 .000 ±		CAGE NUMBER D 78-5100-2517-0		
MAX SURFACE ROUGHNESS		SURFACES		MODEL		REV.	
MARKED ONLY		ANGLES		SHT 1 OF 4		A	

78-5100-2517-0
DRAWING NUMBER

3M™ HM PRESS-FIT HEADER, 8-ROW, HM SERIES
FOR HARD METRIC APPLICATIONS

NOTES
1 CAPS TO BE REMOVED AFTER PRESS-FIT INSTALLATION PROCESS.

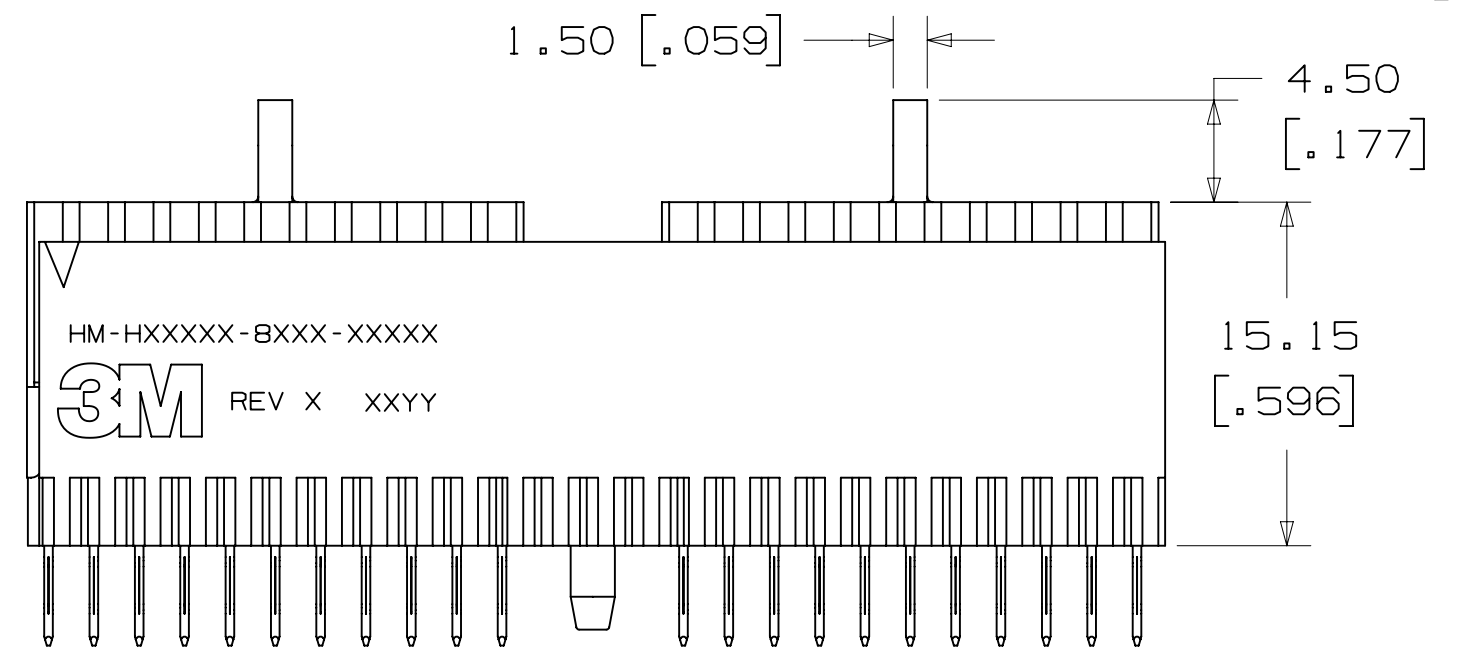
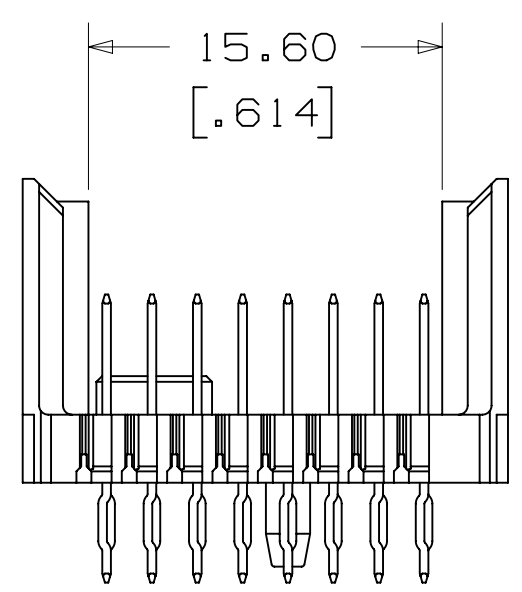
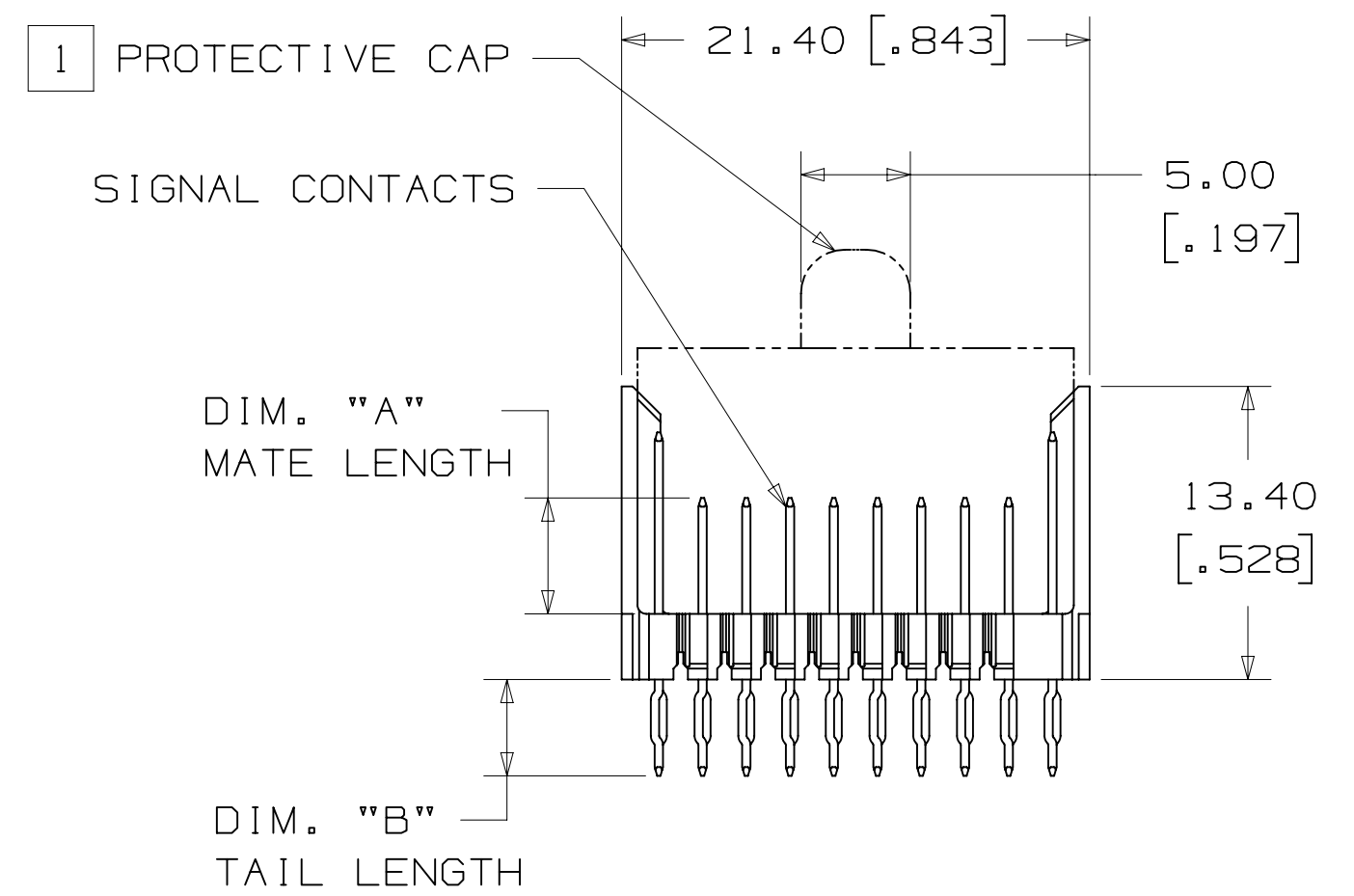
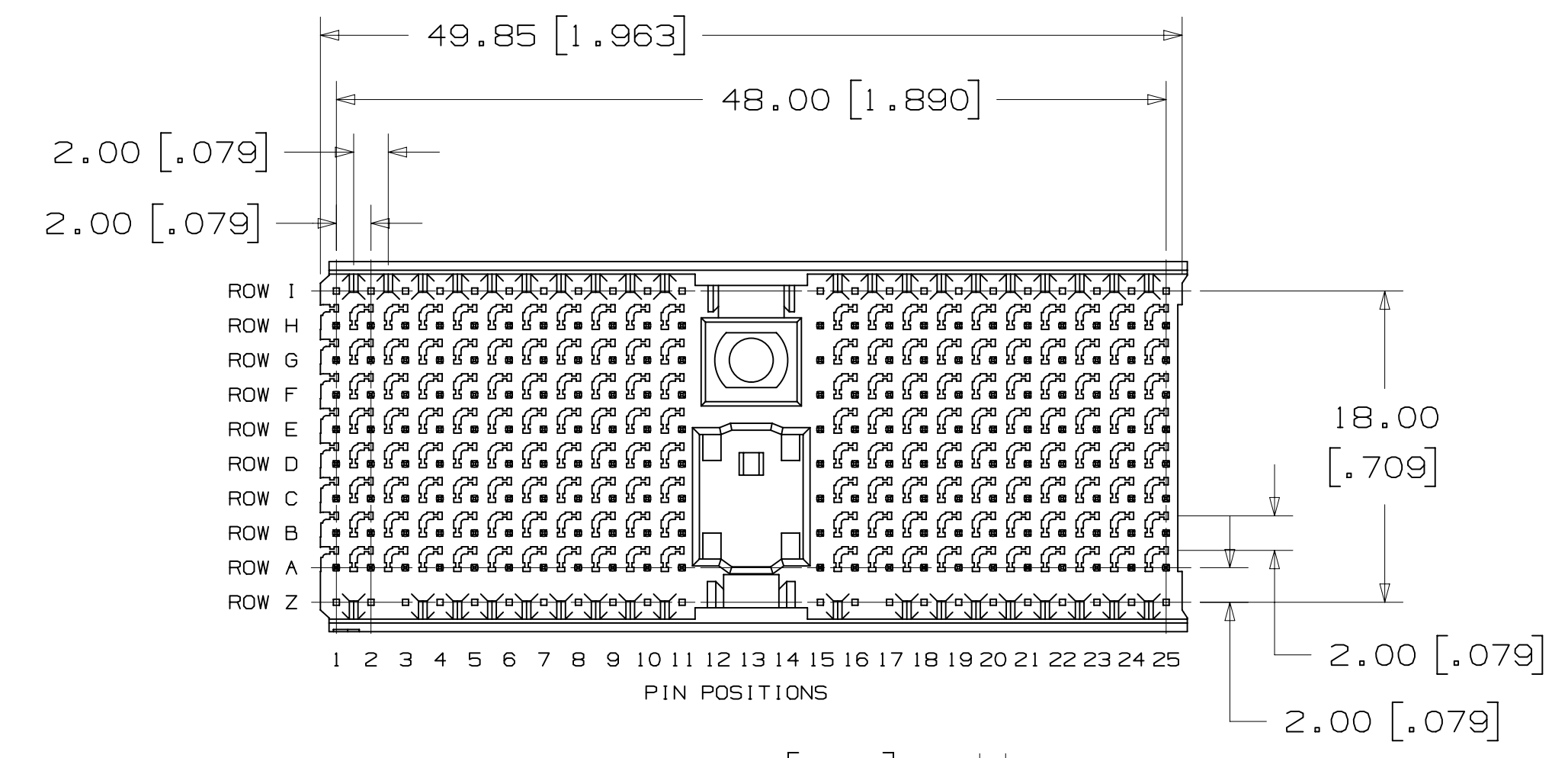
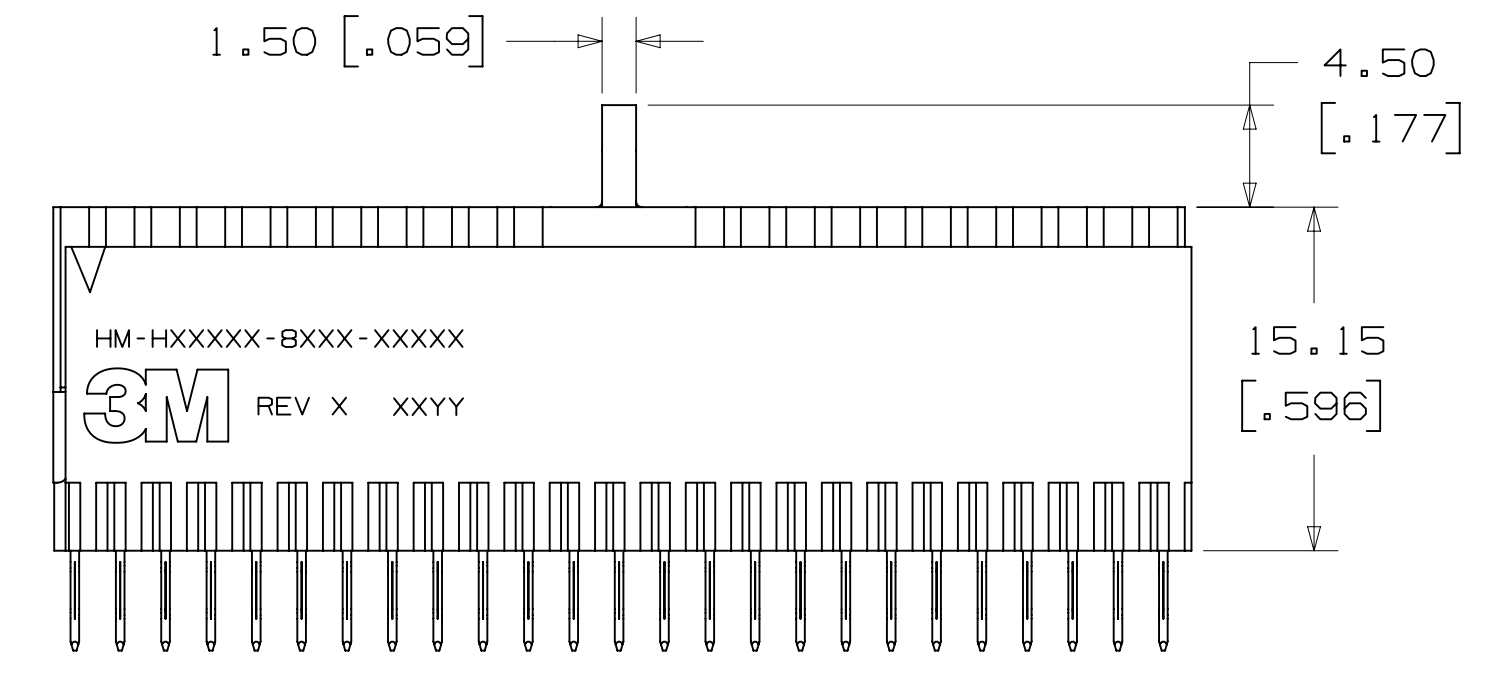
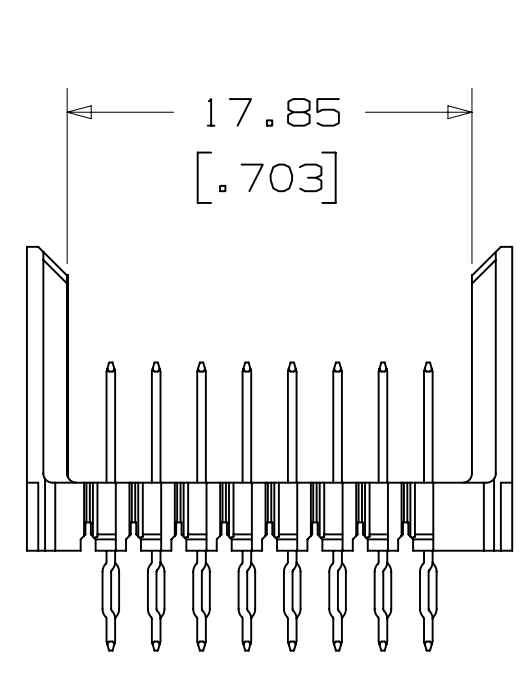
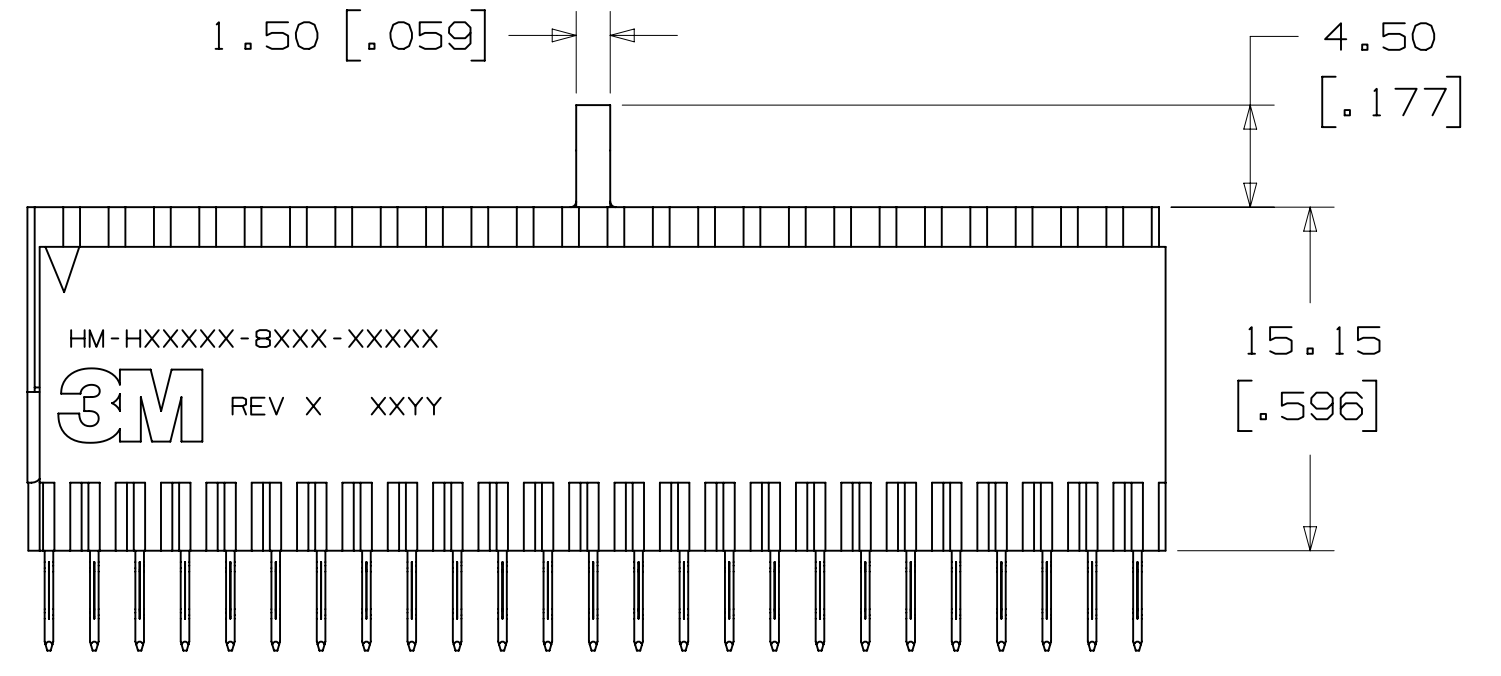
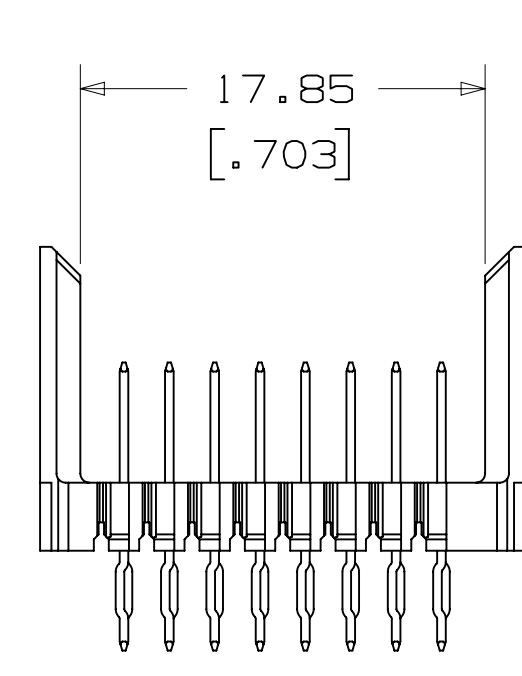
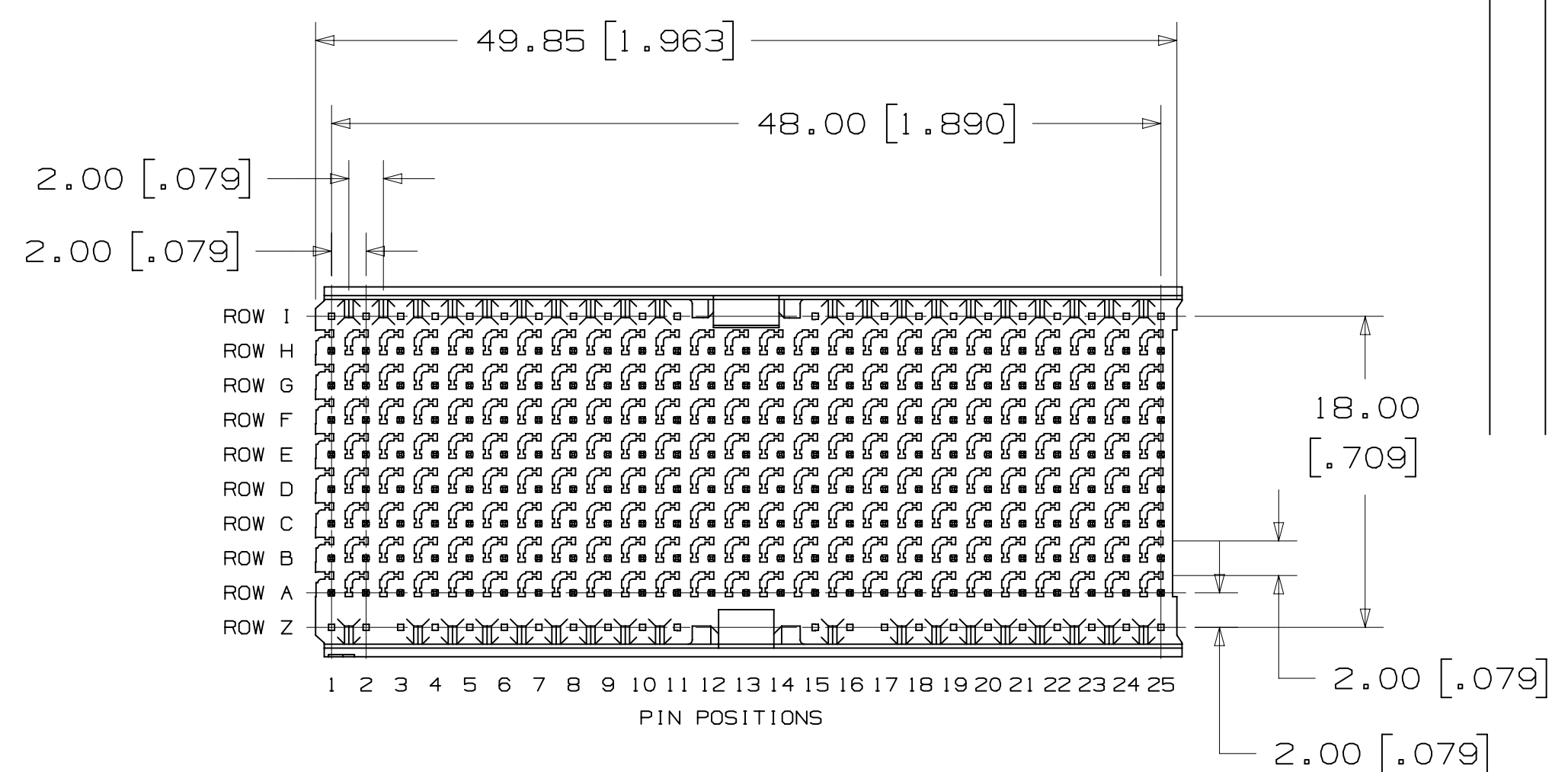
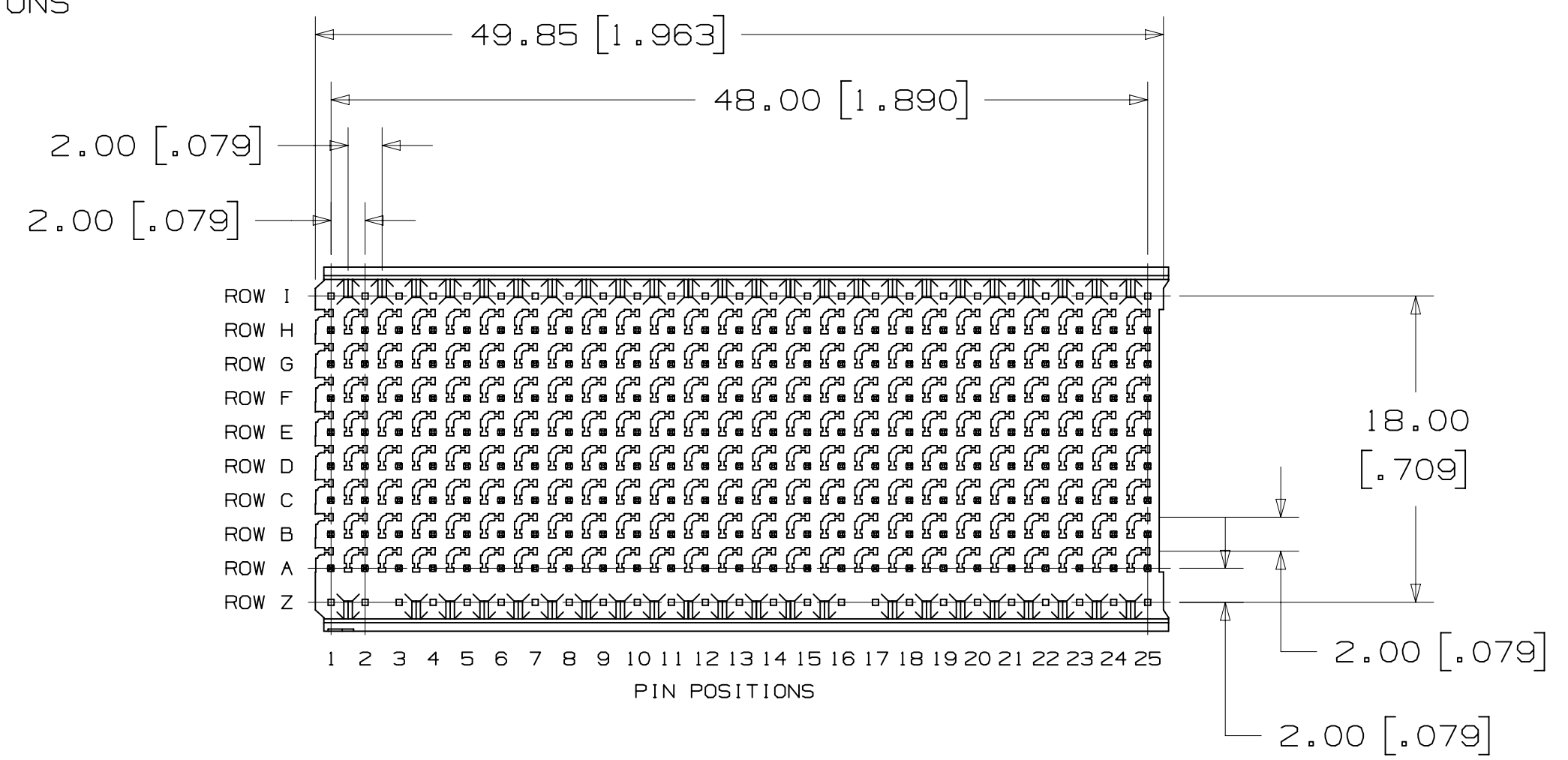

TYPICAL SIDE VIEW DIMENSIONS FOR THE HEADERS ON THIS DRAWING

STANDARD CONFIGURATION
DIM. "A" 5.3 [0.21] FOR ROWS A THRU H
DIM. "B" 4.4 [0.17] EXCEPT AS NOTED
FOR NON-STANDARD CONFIGURATIONS CONTACT A 3M SALES REPRESENTATIVE

DESIGN REFERENCE	NEXT ASSEMBLY	REV	ECO	ISSUE DATE AND DESCRIPTION	DRFT	CHKD
				MFG DATE		
DIVISION		DIVISION CODE		DATE		
Interconnect Solutions		ISD		MFG DATE		
DO NOT SCALE DRAWING	SCALE 3/1	TOLERANCES EXCEPT AS NOTED		DATE		
THIRD ANGLE PROJECTION		INCHES		DATE		
INTERPRET PER ASME Y14.5 - 1994		MILLIMETERS		DATE		
MAX SURFACE ROUGHNESS		SURFACES		DATE		
MARKED ONLY		ANGLES		DATE		
A 39815		MAR 28, 2012		JNC TS		
ECO		PRODUCTION RELEASE		DRFT		CHKD
CASTIGLIONE		MAR 28, 2012		DATE		
APPR		T. SUNIGA		DATE		MAR 28, 2012
3M		© 3M COPYRIGHT 2012		This document and the information it contains are 3M property and may not be reproduced or further distributed without 3M permission, or used or disclosed other than for 3M authorized purposes. All rights reserved.		
TITLE		HM PRESS-FIT HEADER, 8-ROW, HM SERIES				
CAGE NUMBER	SIZE	DRAWING NO.		REV.		
D		78-5100-2517-0		A		
MODEL		ISET		YES NO		SHT 2 OF 4

3M™ HM PRESS-FIT HEADER, 8-ROW, HM SERIES
FOR HARD METRIC APPLICATIONS

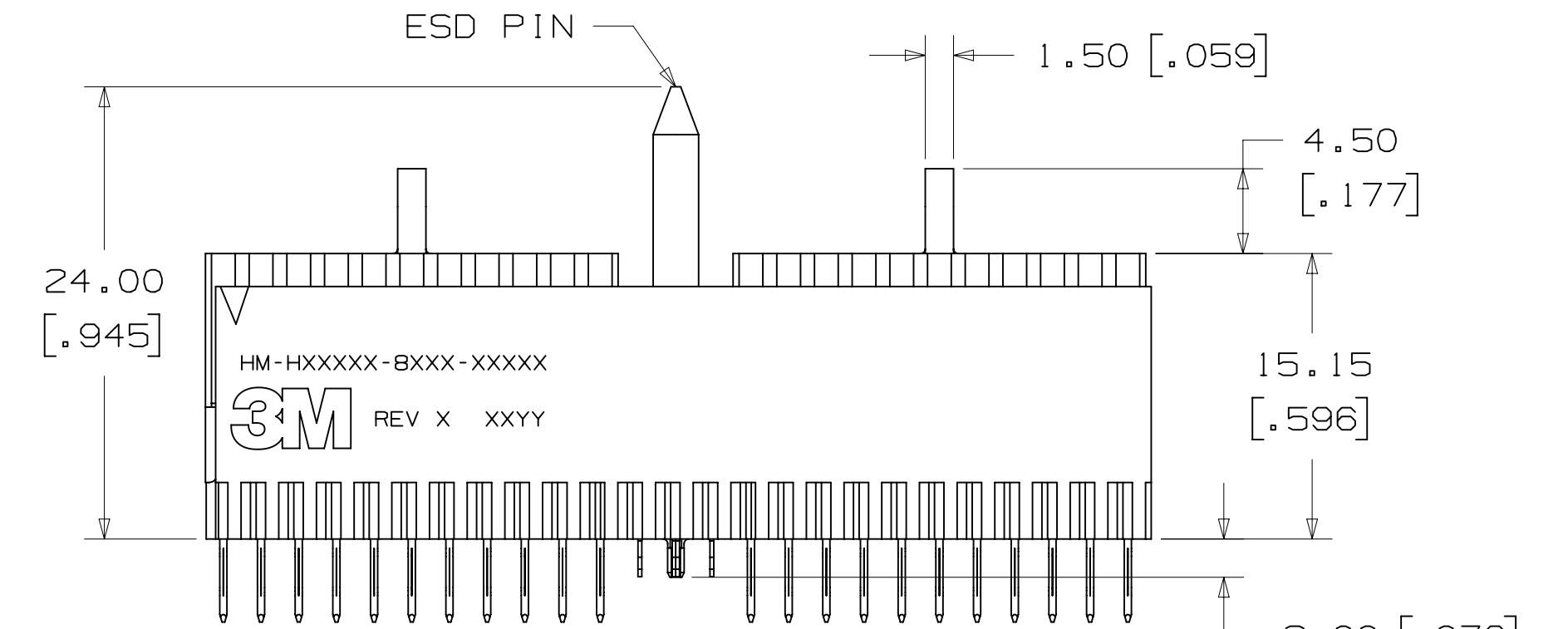
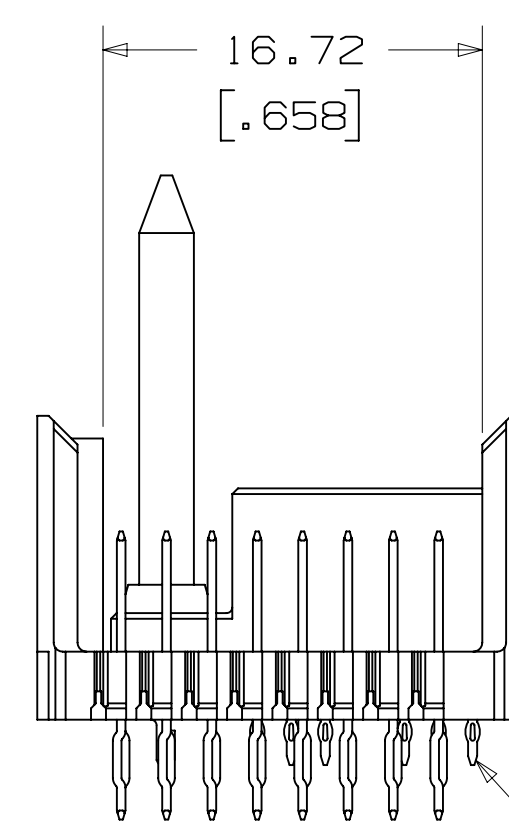
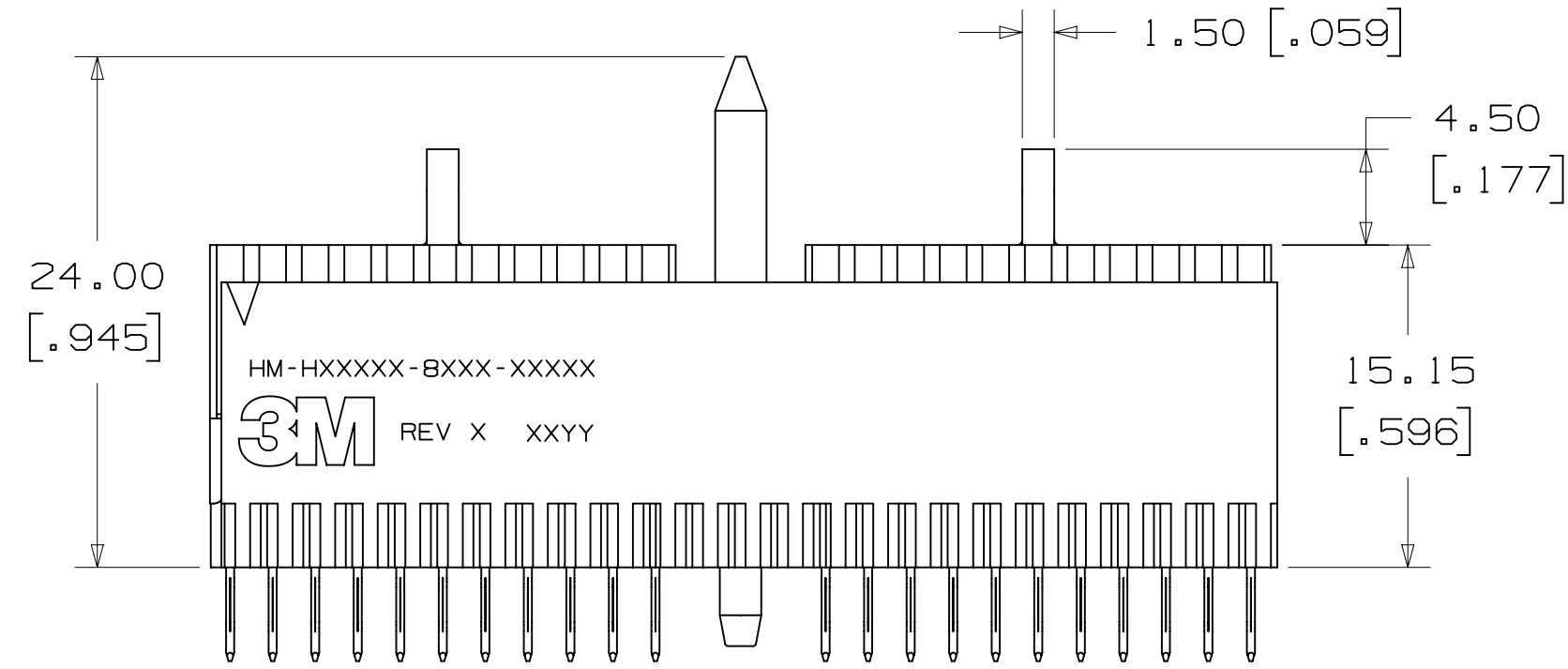
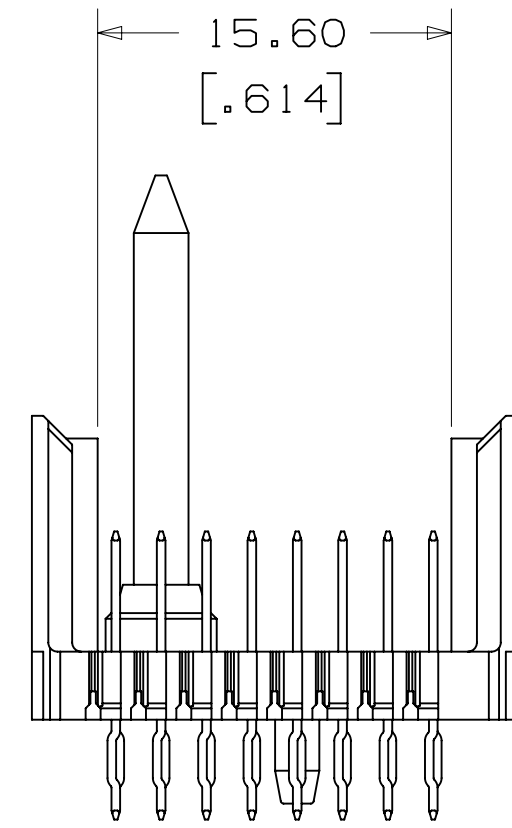
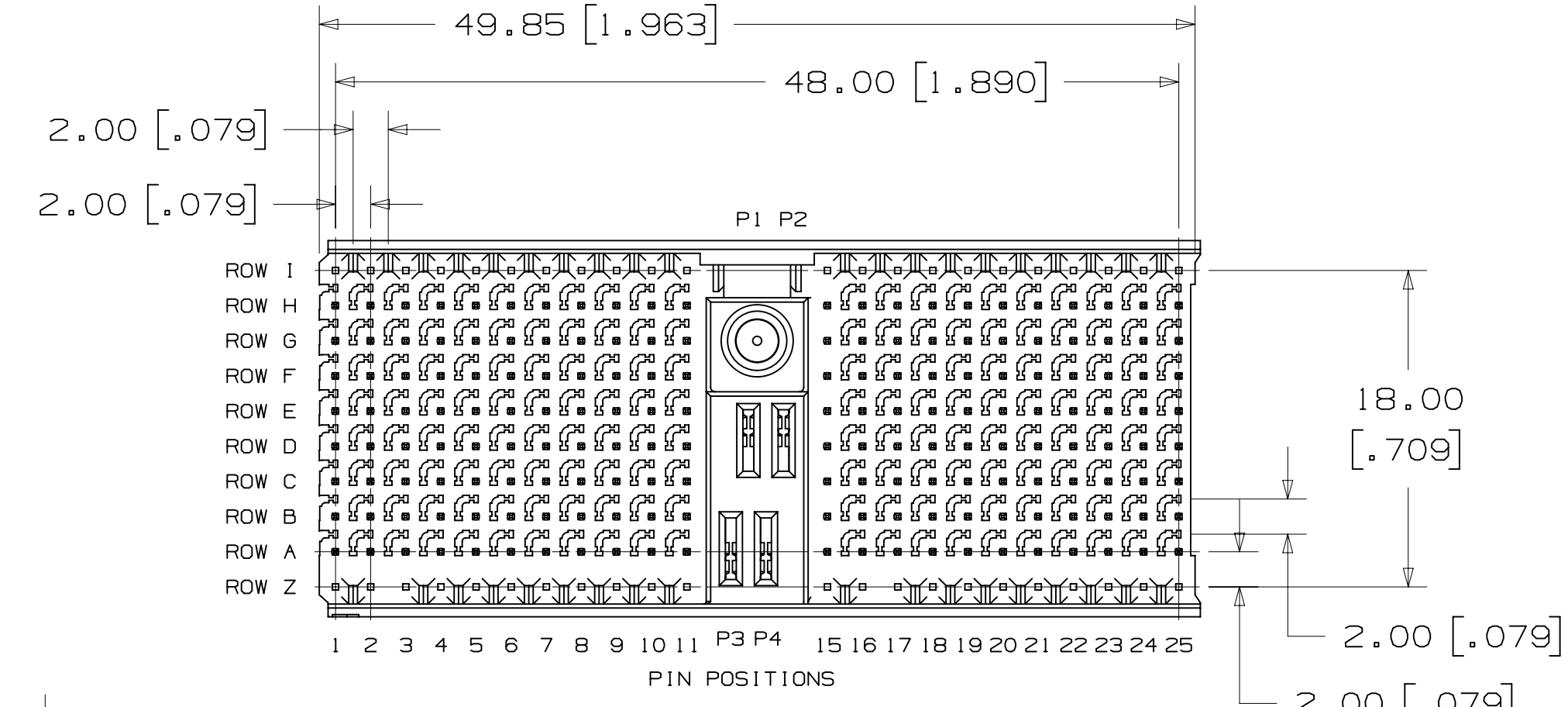
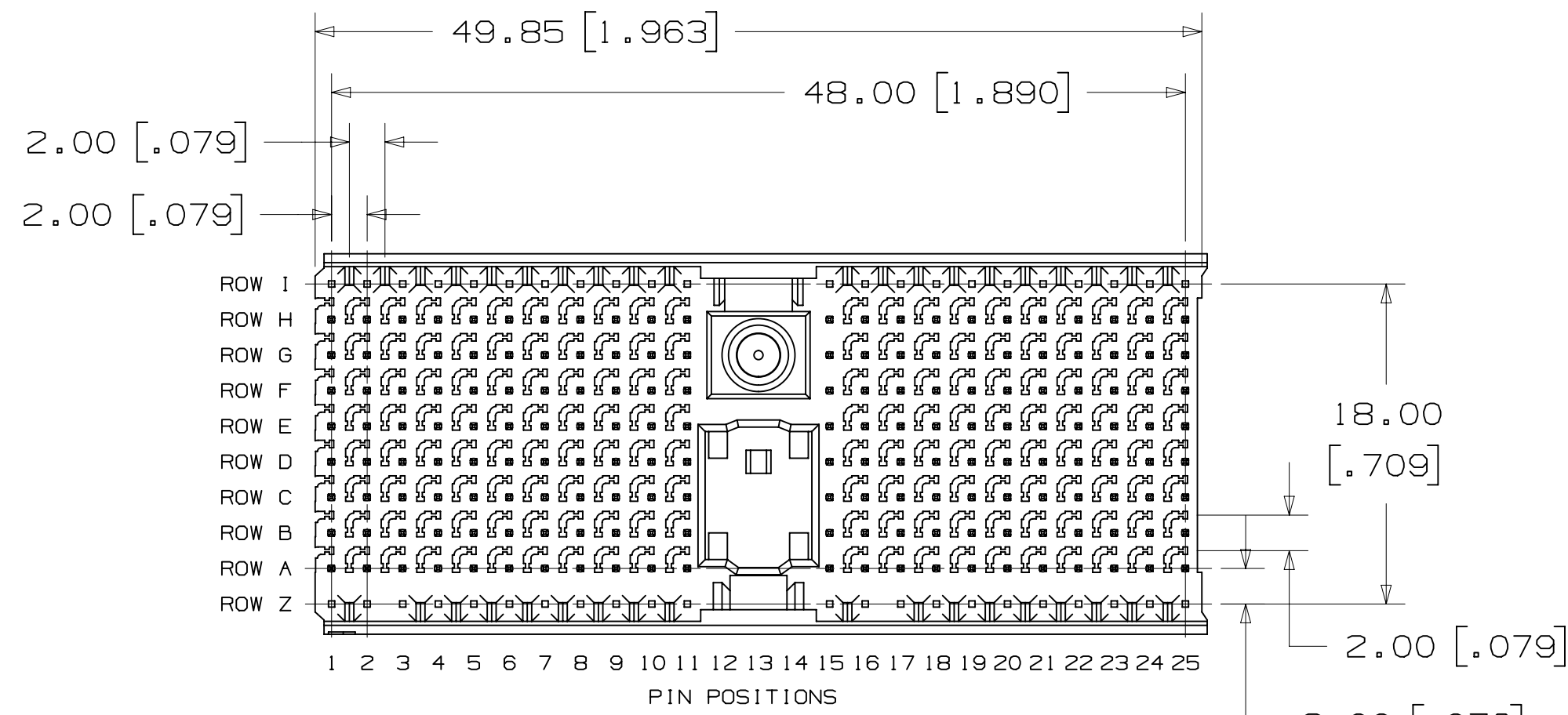

HM-H176DG1-8CX1
HM-H220DG2-8BX1

POWER TAILS
(4 CONTACTS,
12 LEADS)

HM-H176DPWR1-8CXX
HM-H220DPWR2-8BXX

ESD PIN TAIL
LENGTH

DIM. "B" TAIL LENGTH
1 = 4.4 [.17] PIN, 2.0 [.08] POWER
AND 2.0 [.08] ESD
2 = 4.4 [.17] PIN, 4.4 [.17] POWER
AND 2.0 [.08] ESD

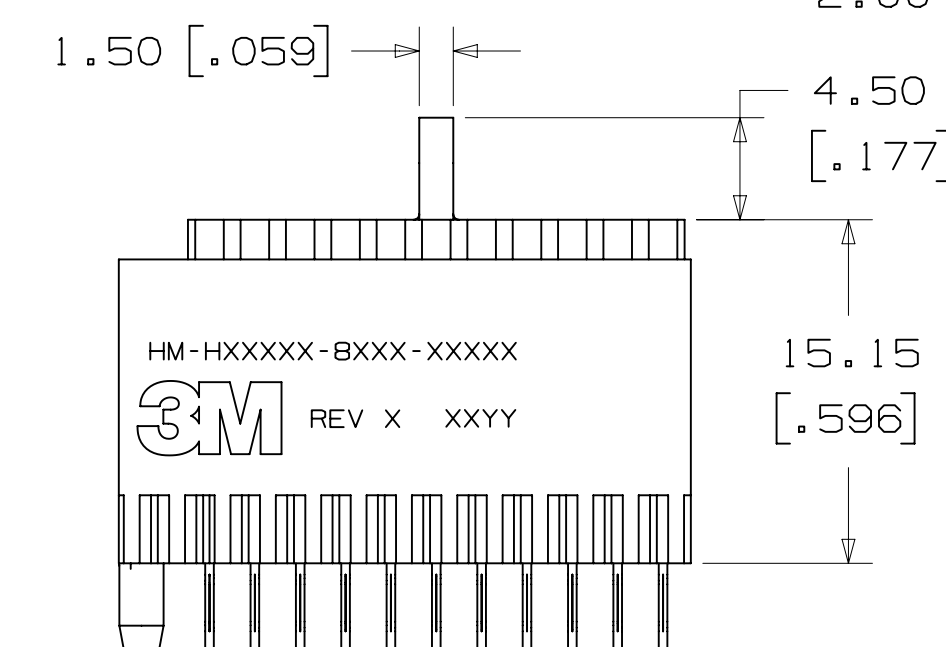
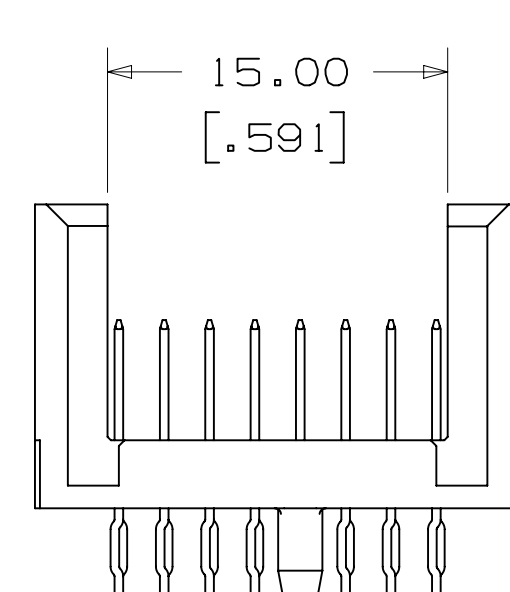
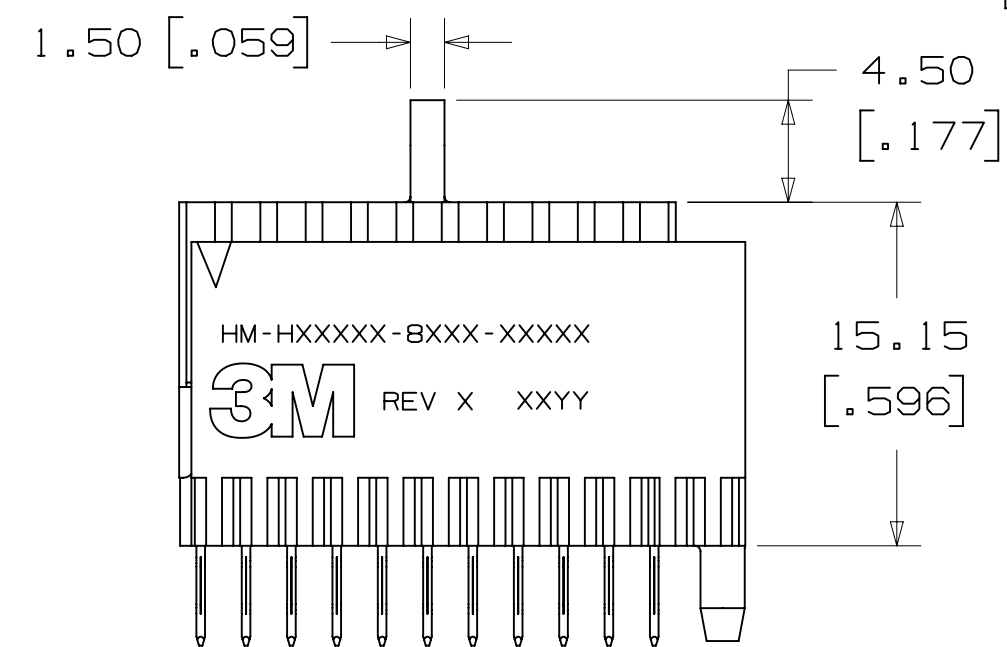
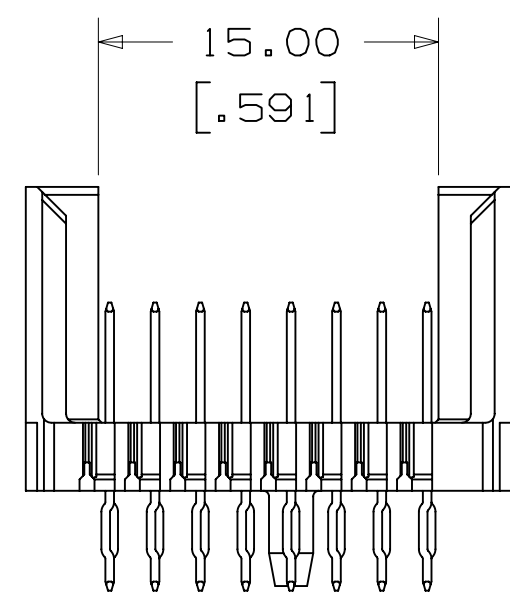
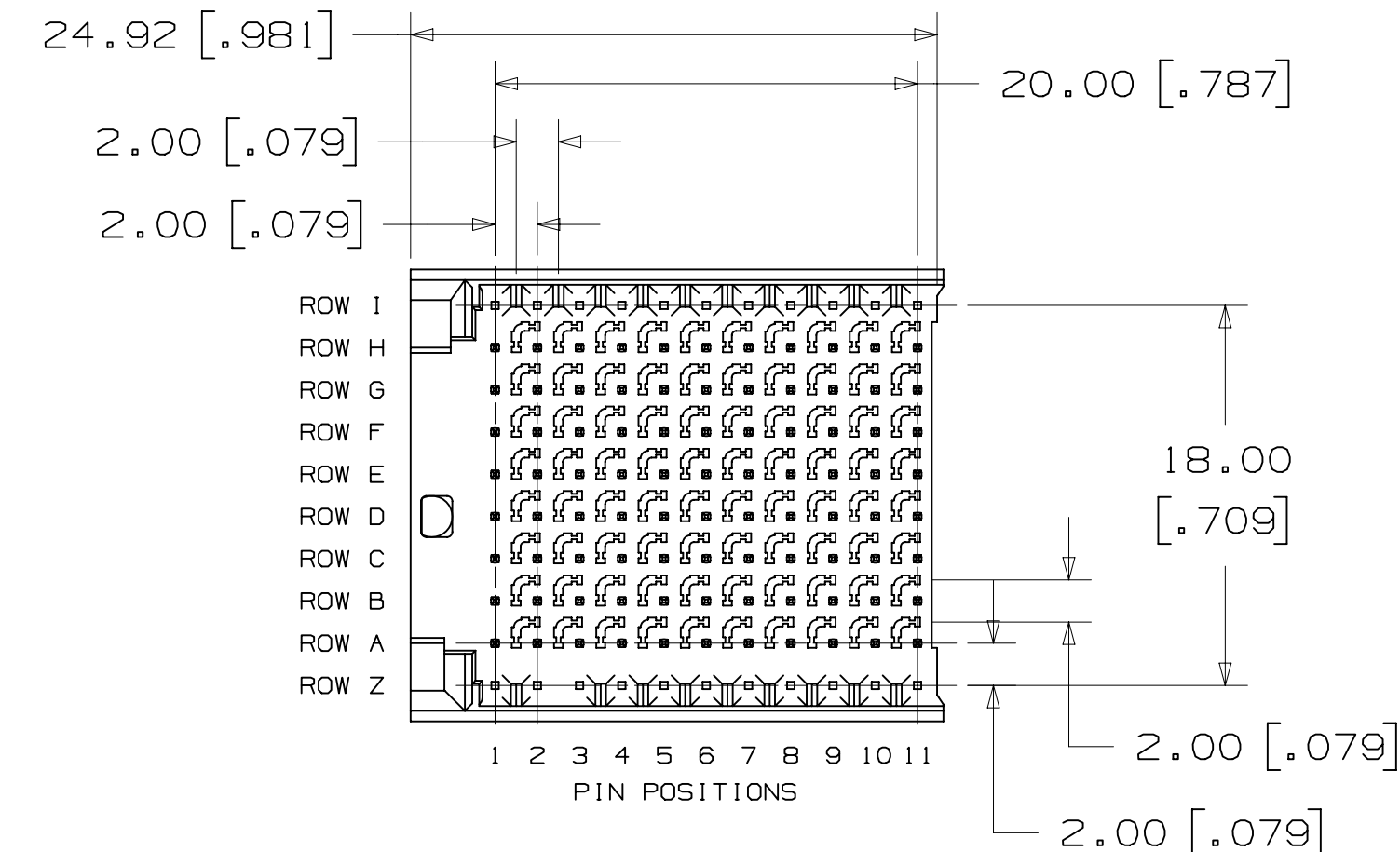
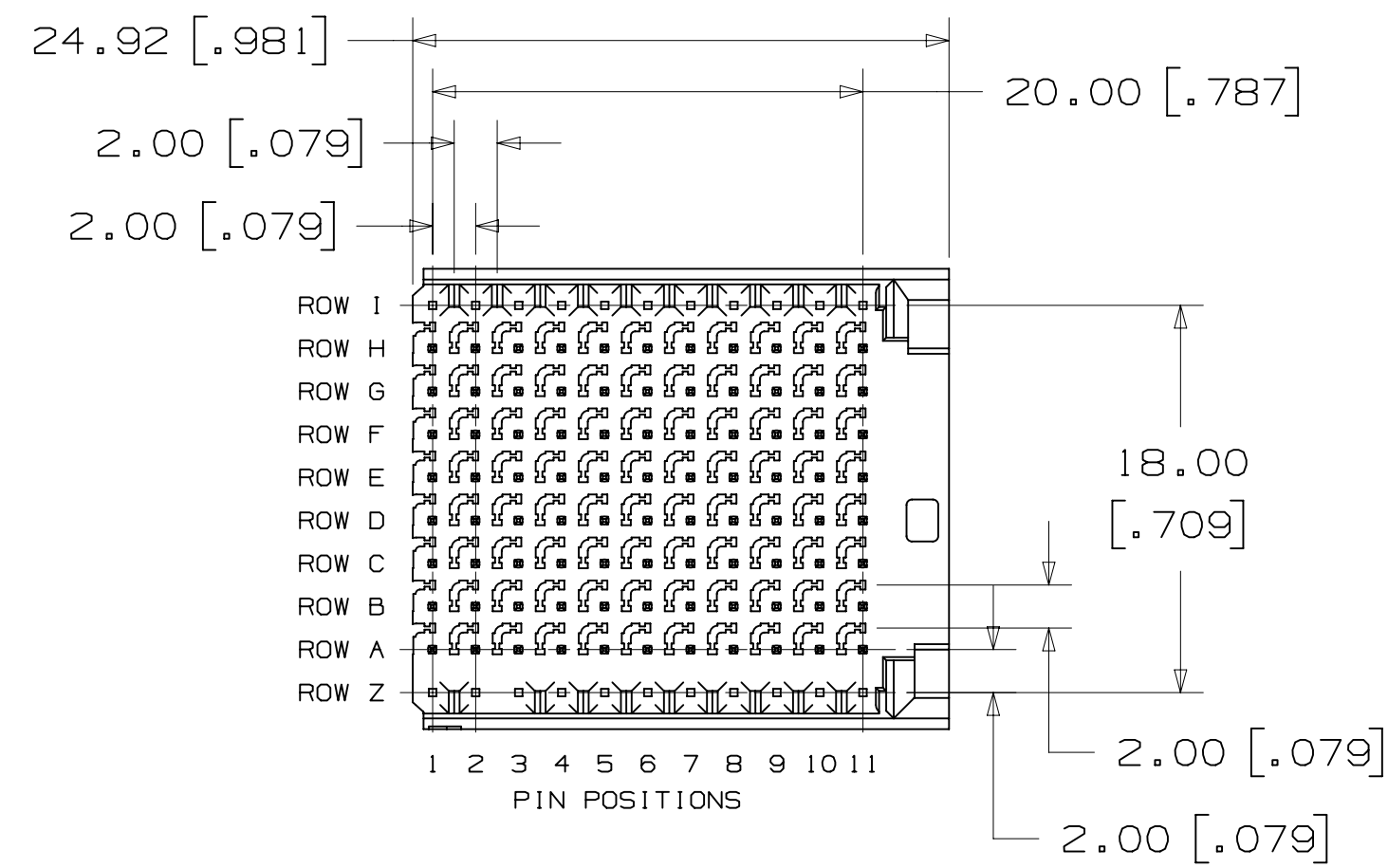

HM-H088FL1-8CX1
HM-H110FL2-8BX1

HM-H088FR1-8CX1
HM-H110FR2-8BXX1

DESIGN REFERENCE	NEXT ASSEMBLY	REV	ECO	ISSUE DATE AND DESCRIPTION	DRFT	CHKD
				MAR 28, 2012		
DIVISION		DIVISION CODE		DATE		
Interconnect Solutions		ISD		MAR 28, 2012		
DO NOT SCALE DRAWING		SCALE		TOLERANCES EXCEPT AS NOTED		
		3/1		INCHES		
				MILLIMETERS		
THIRD ANGLE PROJECTION				0		
INTERPRET PER ASME Y14.5 - 1994				0 ± .3		
MAX SURFACE ROUGHNESS				.00 ± .13		
SURFACES				.000 ±		
MARKED ONLY				ANGLES		
A 39815		MAR 28, 2012		JNC TS		
REV		ECO		ISSUE DATE AND DESCRIPTION		DRFT
CASTIGLIONE		MAR 28, 2012		PRODUCTION RELEASE		
DATE		DATE		DATE		
CHKD		DATE		DATE		
T. SUNIGA		MAR 28, 2012		MAR 28, 2012		
3M		St. Paul, MN 55144		© 3M COPYRIGHT 2012		
TITLE		HM PRESS-FIT HEADER, 8-ROW, HM SERIES				
CAGE NUMBER		SIZE		DRAWING NO.		REV.
D 78-5100-2517-0		A		A		
MODEL		SHT		3 OF 4		

3M™ HM PRESS-FIT HEADER, 8-ROW, HM SERIES
FOR HARD METRIC APPLICATIONS

HOLE	HOLE PLATING TABLE			
	(FINISHED HOLE)	Cu THICKNESS	SnPb THICKNESS	DRILLED HOLE DIA.
DIM. "B"	.690-.790 [.0270-.0310]	.025-.045 [.0010-.0018]	.008-.018 [.0003-.0007]	.810-.860 [.0320-.0340]
DIM. "D"	.550-.650 [.0217-.0256]	.025-.045 [.0010-.0018]	.008-.018 [.0003-.0007]	.686-.727 [.0270-.0286]

1] ROW 1 AND Z HOLES ARE ONLY USED FOR HM-HXXXX2-8BX1 STYLE HEADER.

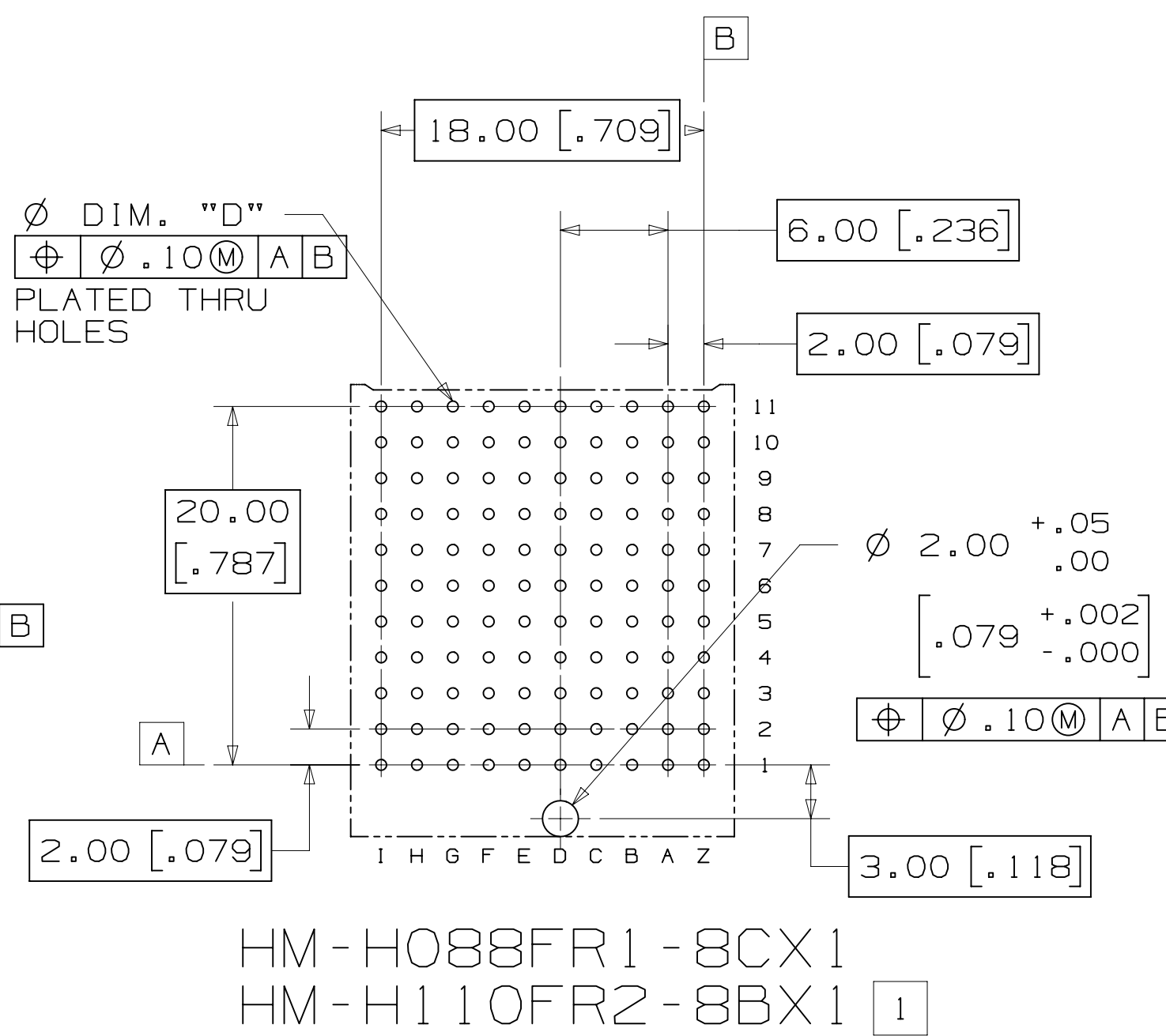
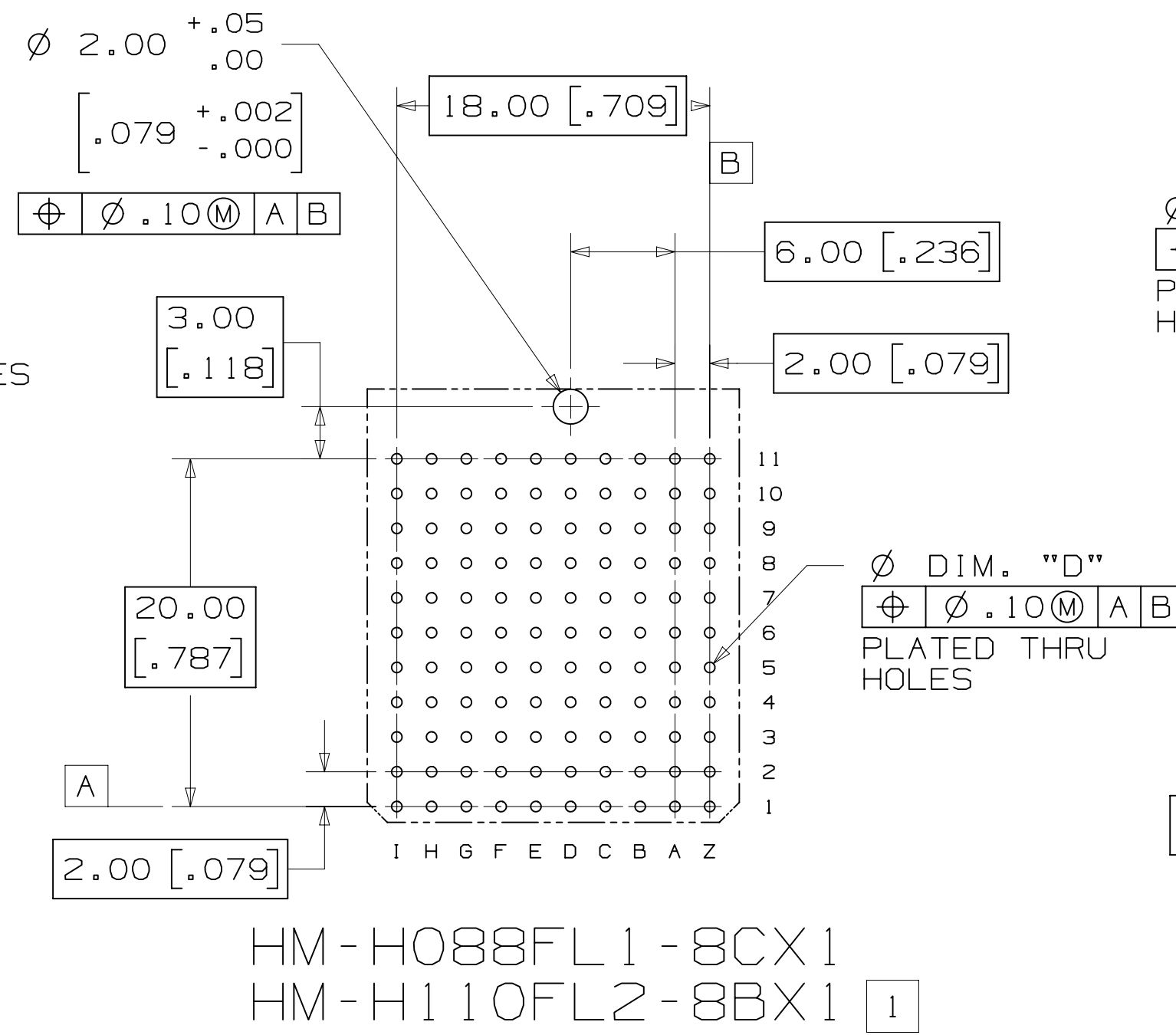
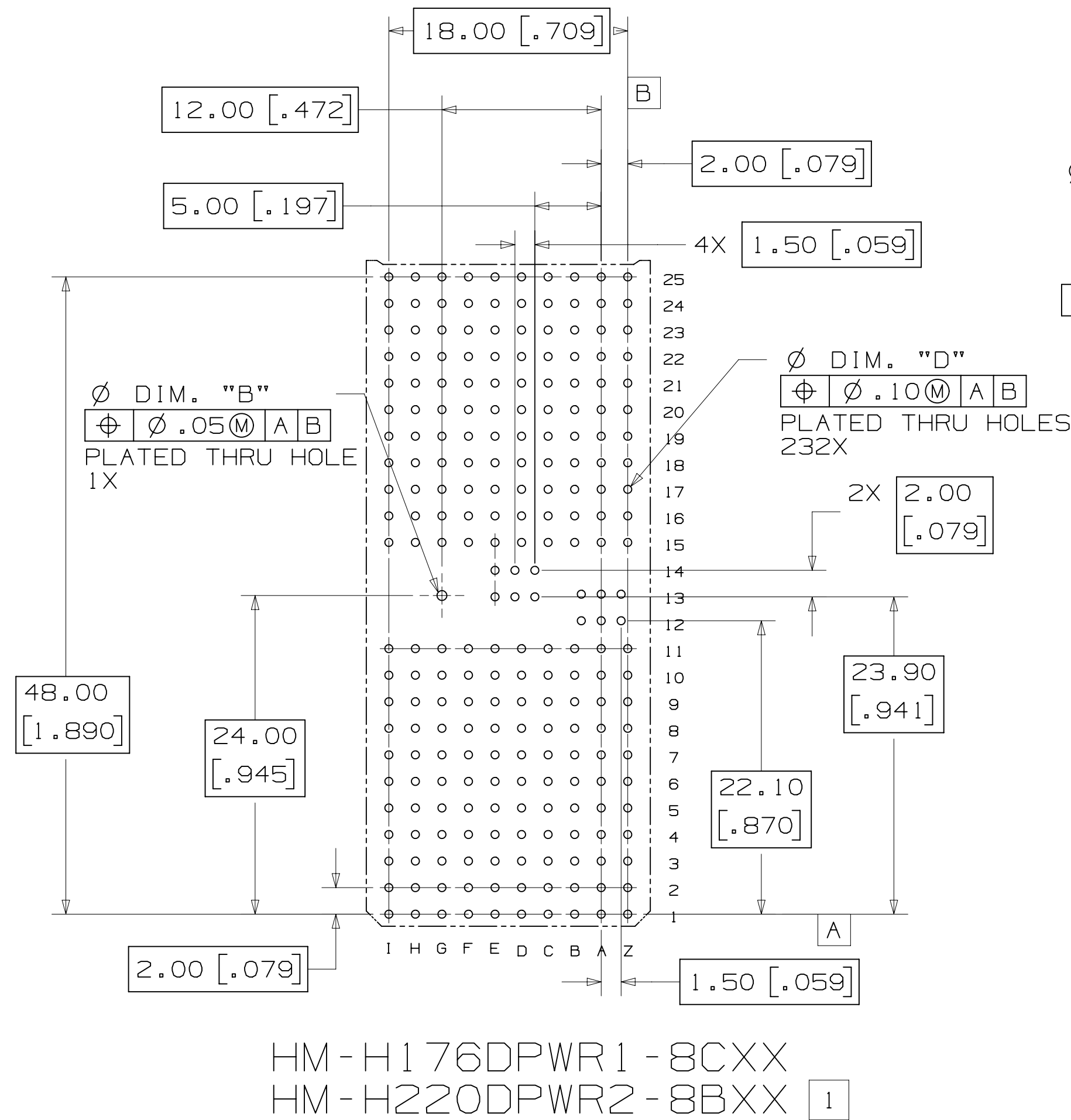
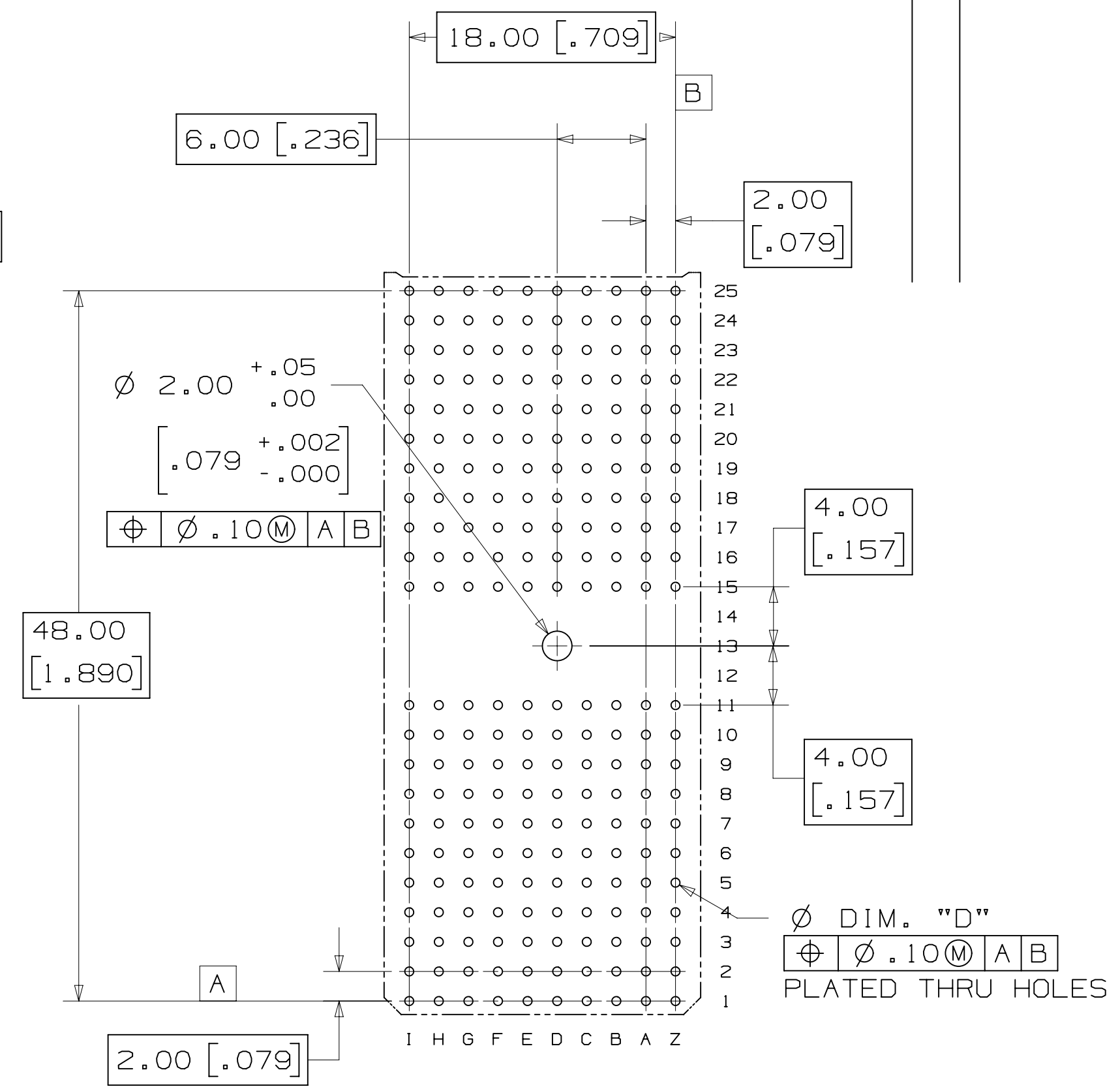
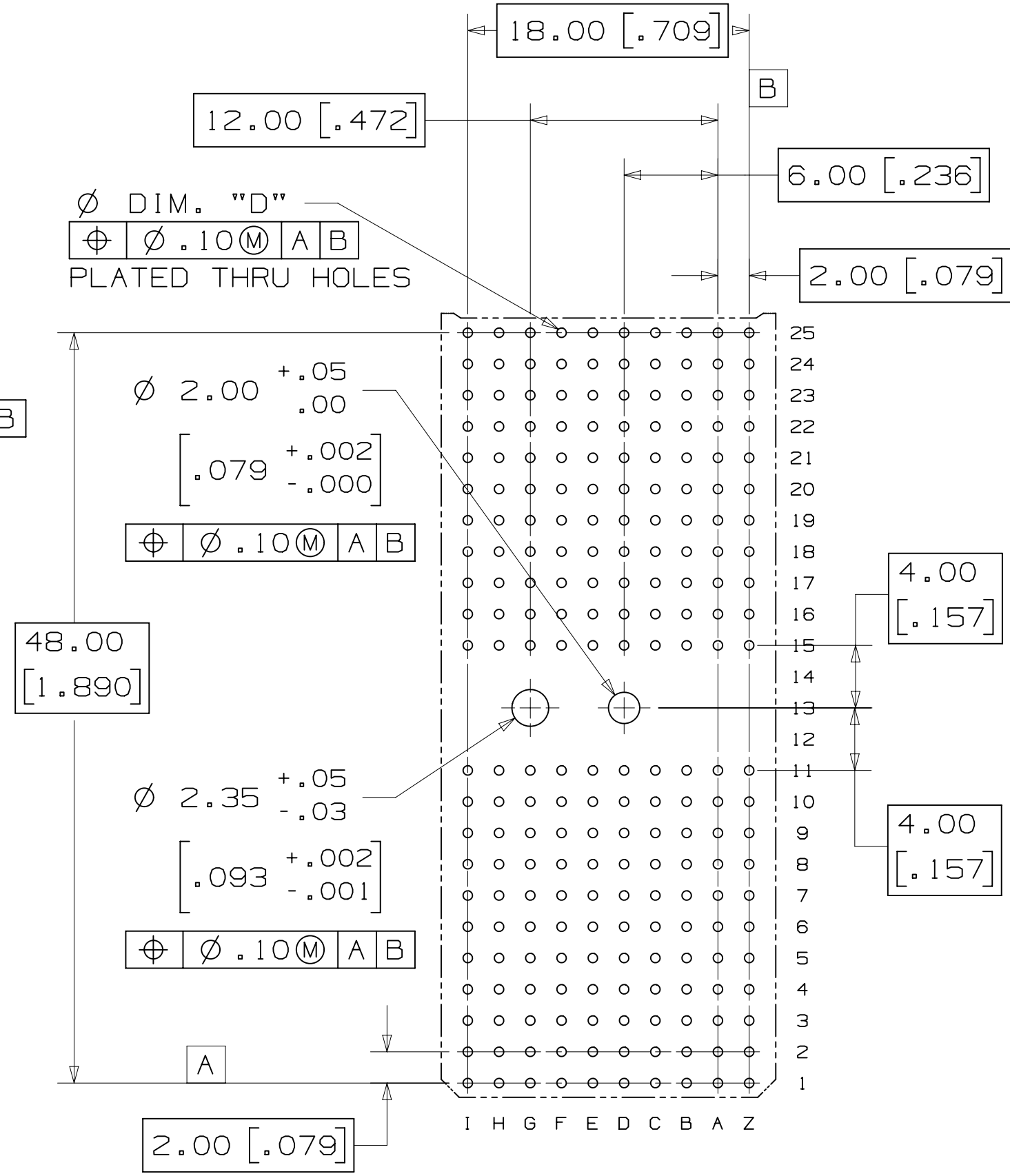
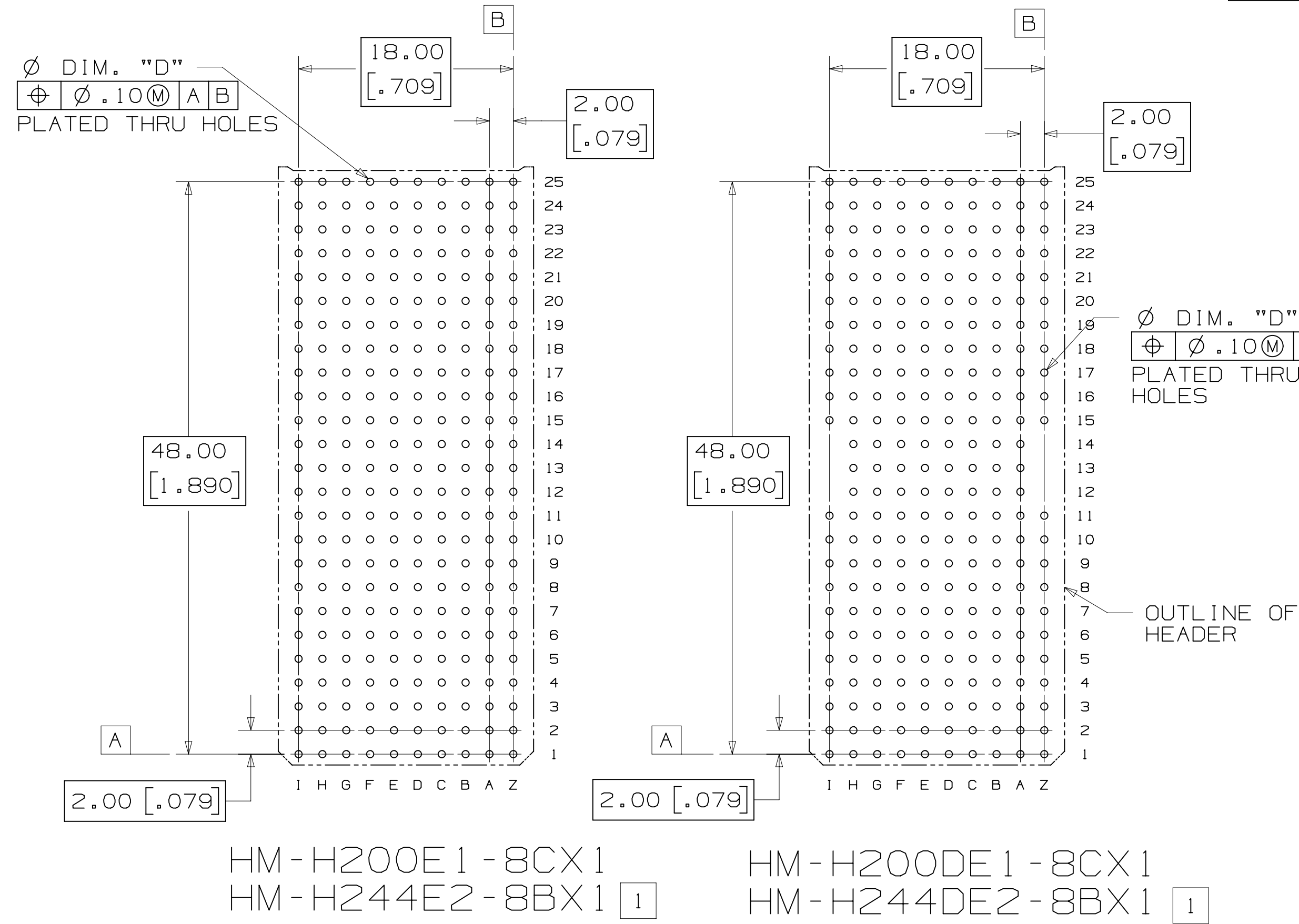

RECOMMENDED PCB MOUNTING HOLE PATTERN
(VIEWED FROM COMPONENT SIDE)

DESIGN REFERENCE	NEXT ASSEMBLY	REV	ECO	ISSUE DATE AND DESCRIPTION	DRFT	CHKD
		A	39815	MAR 28, 2012	JNC	TS
				PRODUCTION RELEASE		
DESIGNER		DATE		MFG DATE		DATE
CASTIGLIONE		MAR 28, 2012				MAR 28, 2012
CHKD		DATE		APPR		DATE
				T. SUNIGA		MAR 28, 2012
DIVISION		DIVISION CODE		DATE		
Interconnect Solutions		ISD				
DO NOT SCALE DRAWING	SCALE 1	TOLERANCES EXCEPT AS NOTED		3M		
THIRD ANGLE PROJECTION		INCHES		© 3M COPYRIGHT 2012		
INTERPRET PER ASME Y14.5 - 1994		MILLIMETERS		This document and the information it contains are 3M property and may not be reproduced or further distributed without 3M permission, or used or disclosed other than for 3M authorized purposes. All rights reserved.		
MAX SURFACE ROUGHNESS		ANGLES		TITLE		
L SURFACES				HM PRESS-FIT HEADER, 8-ROW, HM SERIES		
MARKED ONLY				CAGE NUMBER		
				D 78-5100-2517-0		
				REV. A		
				SHT 4 OF 4		

78-5100-2517-0

Данный компонент на территории Российской Федерации

Вы можете приобрести в компании MosChip.

Для оперативного оформления запроса Вам необходимо перейти по данной ссылке:

<http://moschip.ru/get-element>

Вы можете разместить у нас заказ для любого Вашего проекта, будь то серийное производство или разработка единичного прибора.

В нашем ассортименте представлены ведущие мировые производители активных и пассивных электронных компонентов.

Нашей специализацией является поставка электронной компонентной базы двойного назначения, продукции таких производителей как XILINX, Intel (ex.ALTERA), Vicor, Microchip, Texas Instruments, Analog Devices, Mini-Circuits, Amphenol, Glenair.

Сотрудничество с глобальными дистрибьюторами электронных компонентов, предоставляет возможность заказывать и получать с международных складов практически любой перечень компонентов в оптимальные для Вас сроки.

На всех этапах разработки и производства наши партнеры могут получить квалифицированную поддержку опытных инженеров.

Система менеджмента качества компании отвечает требованиям в соответствии с ГОСТ Р ИСО 9001, ГОСТ РВ 0015-002 и ЭС РД 009

Офис по работе с юридическими лицами:

105318, г.Москва, ул.Щербаковская д.3, офис 1107, 1118, ДЦ «Щербаковский»

Телефон: +7 495 668-12-70 (многоканальный)

Факс: +7 495 668-12-70 (доб.304)

E-mail: info@moschip.ru

Skype отдела продаж:

moschip.ru

moschip.ru_4

moschip.ru_6

moschip.ru_9