



NXP low-power 3D HDMI transmitter TDA19988 in TFBGA64

Deliver 3D full HD in mobile apps with HDMI 1.4a transmitter

This advanced transmitter enhances mobile phones, DSCs, DVCs, and tablet PCs by providing 3D full HD up to 1080p, "x.v.Color", and CEC – at unprecedented power savings, size and cost.

Key features

- ▶ 3D frame packing, side by side, top-bottom, up to 1080p
- ▶ 60 mW power consumption in 720p 50/60 Hz
- ▶ <20 μ W power consumption in standby mode
- ▶ "x.v.Color" support, including Adobe RGB
- ▶ Embedded CEC without external oscillator
- ▶ HDCP 1.4
- ▶ RGB, YCbCr, DDR, ITU656 support
- ▶ Two I²S-bus audio input channels, one SPDIF channel
- ▶ Software drivers
- ▶ TFBGA64 package (4.5 x 4.5 x 0.95 mm, 64 balls)

Key benefits

- ▶ HD ready and Full HD 1080p 3D solution
- ▶ Extremely low power
- ▶ Optimized BoM
- ▶ Flexible design-in for easy system integration
- ▶ Fast time-to-market
- ▶ Smallest available package with full 24-bit RGB interface

Applications

- ▶ Mobile phones
- ▶ Tablet PCs
- ▶ Digital still cameras (DSCs)
- ▶ Digital video cameras (DVCs)
- ▶ Docking stations

This HDMI 1.4a transmitter, optimized for use in mobile applications, is already in mass production with major mobile phone manufacturers, using platforms from Qualcomm, Texas Instruments (OMAP), and Mediatek. Available in a TFBGA package that measures only 4.5 x 4.5 x 0.95 mm, it delivers best-in-class footprint with a full 24-bit RGB interface. For added convenience, it is HDMI, HDCP, and CEC certification compliant.



Development tools

The development kit includes an evaluation board and a standard schematic and layout, as well as Android and standard drivers with example applications.

Authorized Test Center (ATC)

NXP's ATC laboratory, located in Caen, France, qualifies and certifies devices according to HDMI, HDCP, and CEC requirements.

TDA19988xET block diagram

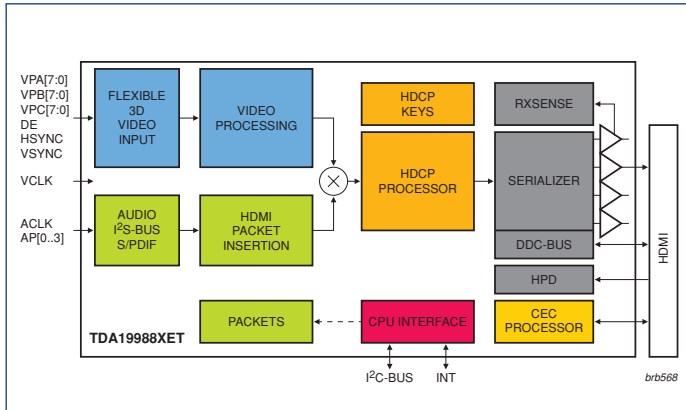

Evaluation tool includes an evaluation board and a standard schematic and layout, as well as Android and standard drivers with example applications

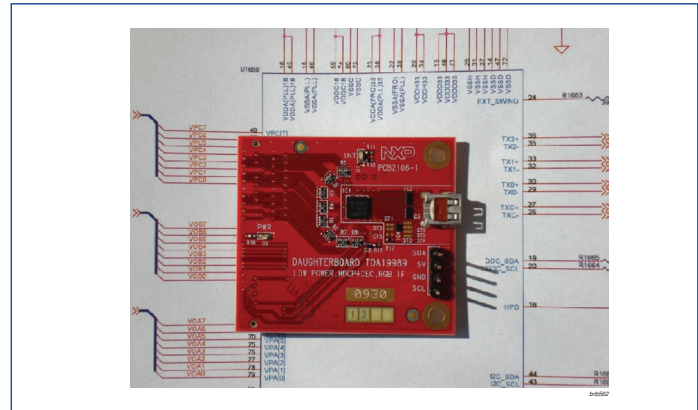

Use cases: smartphone, camcorder, table PC, camera



The TFBGA version is the smallest package available with a full 24-bit RGB interface

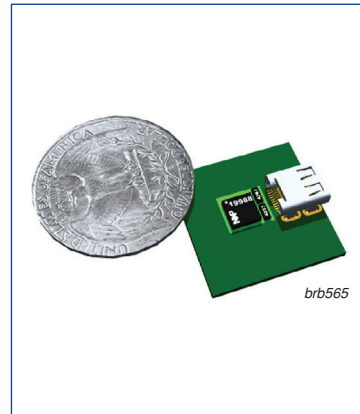

Sample TDA19988xET application

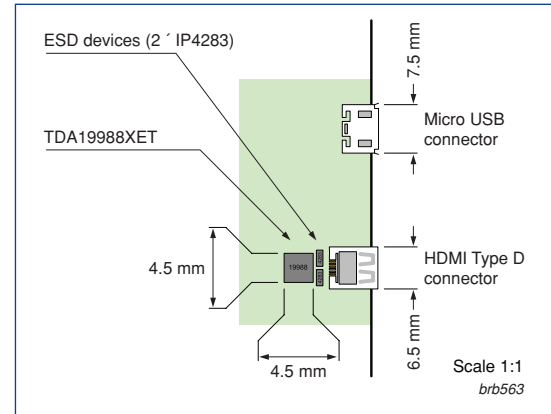

Type number	Description	Package
TDA19988AET	NXP HDMI 1.4a transmitter with HDCP encryption engine	TFBGA64 (4.5 x 4.5 x 0.95 mm, 64 balls)
TDA19988BET	NXP HDMI 1.4a transmitter without HDCP encryption engine	TFBGA64 (4.5 x 4.5 x 0.95 mm, 64 balls)

HDMI

www.nxp.com

© 2011 NXP Semiconductors N.V.

All rights reserved. Reproduction in whole or in part is prohibited without the prior written consent of the copyright owner. The information presented in this document does not form part of any quotation or contract, is believed to be accurate and reliable and may be changed without notice. No liability will be accepted by the publisher for any consequence of its use. Publication thereof does not convey nor imply any license under patent- or other industrial or intellectual property rights.

Date of release: April 2011

Document order number: 9497 750 1717

Printed in the Netherlands

Данный компонент на территории Российской Федерации

Вы можете приобрести в компании MosChip.

Для оперативного оформления запроса Вам необходимо перейти по данной ссылке:

<http://moschip.ru/get-element>

Вы можете разместить у нас заказ для любого Вашего проекта, будь то серийное производство или разработка единичного прибора.

В нашем ассортименте представлены ведущие мировые производители активных и пассивных электронных компонентов.

Нашей специализацией является поставка электронной компонентной базы двойного назначения, продукции таких производителей как XILINX, Intel (ex.ALTERA), Vicor, Microchip, Texas Instruments, Analog Devices, Mini-Circuits, Amphenol, Glenair.

Сотрудничество с глобальными дистрибьюторами электронных компонентов, предоставляет возможность заказывать и получать с международных складов практически любой перечень компонентов в оптимальные для Вас сроки.

На всех этапах разработки и производства наши партнеры могут получить квалифицированную поддержку опытных инженеров.

Система менеджмента качества компании отвечает требованиям в соответствии с ГОСТ Р ИСО 9001, ГОСТ РВ 0015-002 и ЭС РД 009

Офис по работе с юридическими лицами:

105318, г.Москва, ул.Щербаковская д.3, офис 1107, 1118, ДЦ «Щербаковский»

Телефон: +7 495 668-12-70 (многоканальный)

Факс: +7 495 668-12-70 (доб.304)

E-mail: info@moschip.ru

Skype отдела продаж:

moschip.ru

moschip.ru_4

moschip.ru_6

moschip.ru_9