



CM1402

Features

- Functionally and pin compatible with CMD's CSPEMI400
- *OptiGuard* coated for improved reliability at assembly
- Three channels of EMI filtering, each with ESD protection
- Two additional channels of ESD-only protection
- $\pm 10\text{kV}$ ESD protection (IEC 61000-4-2, contact discharge) on all pins
- $\pm 25\text{kV}$ ESD protection (HBM)
- Greater than 30dB of attenuation at 1GHz
- 10-bump, 1.960mm x 1.330mm footprint Chip Scale Package (CSP)
- Chip Scale Package features extremely low lead inductance for optimum filter and ESD performance
- RoHS-compliant, lead-free packaging

Applications

- SIM Card slot in mobile handsets
- I/O port protection for mobile handsets, notebook computers, PDAs, etc.
- EMI filtering for data ports in cell phones, PDAs or notebook computers

Product Description

The CM1402 is an EMI filter array with ESD protection, which integrates three pi filters (C-R-C) and two additional channels of ESD protection. The CM1402 has component values of 20pF-47 Ω -20pF, and 20pF-100 Ω -20pF. The parts include avalanche-type ESD diodes on every pin, which provide a very high level of protection for sensitive electronic components that may be subjected to electrostatic discharge (ESD). The ESD diodes connected to the filter ports are designed and characterized to safely dissipate ESD strikes of $\pm 10\text{kV}$, beyond the maximum requirement of the IEC 61000-4-2 international standard. Using the MIL-STD-883 (Method 3015) specification for Human Body Model (HBM) ESD, the pins are protected for contact discharges at greater than $\pm 25\text{kV}$.

The ESD diodes on pins A4 and C4 ports are designed and characterized to safely dissipate ESD strikes of $\pm 10\text{kV}$, well beyond the maximum requirement of the IEC 61000-4-2 international standard.

This device is particularly well suited for portable electronics (e.g. mobile handsets, PDAs, notebook computers) because of its small package format and easy-to-use pin assignments. In particular, the CM1402 is ideal for EMI filtering and protecting data lines from ESD for the SIM card slot in mobile handsets.

The CM1402 incorporates *OptiGuard* coating which results in improved reliability at assembly. The CM1402 is available in a space-saving, low-profile Chip Scale Package.

Electrical Schematic

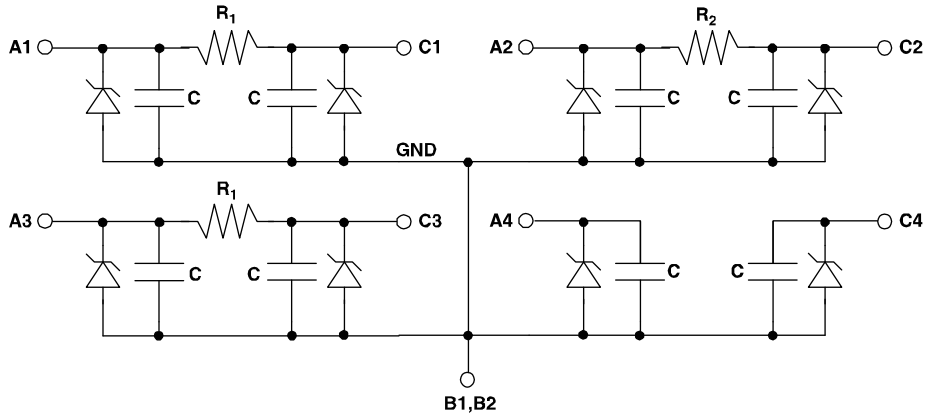

$R_1=100\Omega$
 $R_2=47\Omega$

PACKAGE / PINOUT DIAGRAMS

TOP VIEW
(Bumps Down View)

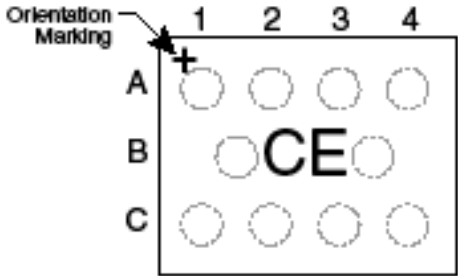

BOTTOM VIEW
(Bumps Up View)

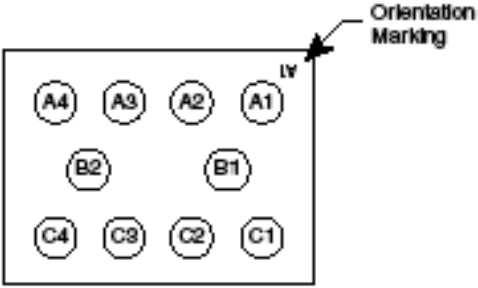

CM1402
 CSP Package with
 OptiGuard Coating

Notes:
 1) These drawings are not to scale.

CM1402

PIN DESCRIPTIONS

TYPE	PIN	DESCRIPTION
EMI Filter	A1	EMI Filter with ESD Protection for RST Signal
	C1	EMI Filter with ESD Protection for RST Signal
EMI Filter	A2	EMI Filter with ESD Protection for CLK Signal
	C2	EMI Filter with ESD Protection for CLK Signal
Device Ground	B1	Device Ground
	B2	Device Ground
EMI Filter	A3	EMI Filter with ESD Protection for DAT Signal
	C3	EMI Filter with ESD Protection for DAT Signal
ESD Channel	A4	ESD Protection Channel - V_{CC} Supply
ESD Channel	C4	ESD Protection Channel

Ordering Information

PART NUMBERING INFORMATION

Bumps	Package	Lead-free Finish	
		Ordering Part Number ¹	Part Marking
10	CSP	CM1402-03CP	CE

Note 1: Parts are shipped in Tape and Reel form unless otherwise specified.

Specifications

ABSOLUTE MAXIMUM RATINGS

PARAMETER	RATING	UNITS
Storage Temperature Range	-65 to +150	°C
DC Power per Resistor	100	mW
DC Package Power Rating	300	mW

STANDARD OPERATING CONDITIONS

PARAMETER	RATING	UNITS
Operating Temperature Range	-40 to +85	°C

ELECTRICAL OPERATING CHARACTERISTICS¹

SYMBOL	PARAMETER	CONDITIONS	MIN	TYP	MAX	UNITS
R_1	Resistance of R_1		80	100	120	Ω
R_2	Resistance of R_2		38	47	56	Ω
C	Capacitance	$V_{IN} = 2.5VDC, 1MHz,$ 30mV ac	16	20	24	pF
$V_{STANDOFF}$	Stand-off Voltage	$I = 10\mu A$		6.0		V
I_{LEAK}	Diode Leakage Current	$V_{BIAS} = 3.3V$		0.1	1.0	μA
V_{SIG}	Signal Voltage Positive Clamp Negative Clamp	$I_{LOAD} = 10mA$ $I_{LOAD} = -10mA$	5.6 -1.5	6.8 -0.8	9.0 -0.4	V V
V_{ESD}	In-system ESD Withstand Voltage	Notes 2 and 4				
	a) Human Body Model, MIL-STD-883, Method 3015 b) Contact Discharge per IEC 61000-4-2		± 25 ± 10			kV kV
V_{CL}	Clamping Voltage during ESD Discharge MIL-STD-883 (Method 3015), 8kV Positive Transients Negative Transients	Notes 2,3, and 4			+12 -7	V V
f_{C1}	Cut-off frequency $Z_{SOURCE} = 50\Omega, Z_{LOAD} = 50\Omega$	$R = 100\Omega, C = 20pF$		77		MHz
f_{C2}	Cut-off frequency $Z_{SOURCE} = 50\Omega, Z_{LOAD} = 50\Omega$	$R = 47\Omega, C = 20pF$		85		MHz

Note 1: $T_A = 25^\circ C$ unless otherwise specified.

Note 2: ESD applied to input and output pins with respect to GND, one at a time.

Note 3: Clamping voltage is measured at the opposite side of the EMI filter to the ESD pin. For example, if ESD is applied to Pin A1, then clamping voltage is measured at Pin C1.

Note 4: Unused pins are left open.

Performance Information

Typical Filter Performance (nominal conditions unless specified otherwise, 50 Ohm Environment)

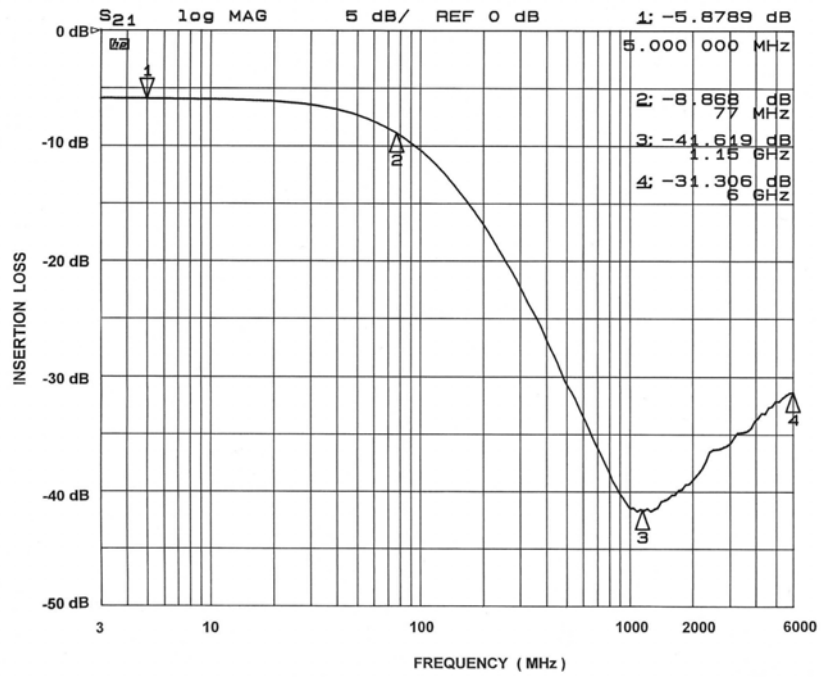

Figure 1. A1-C1 EMI Filter Performance

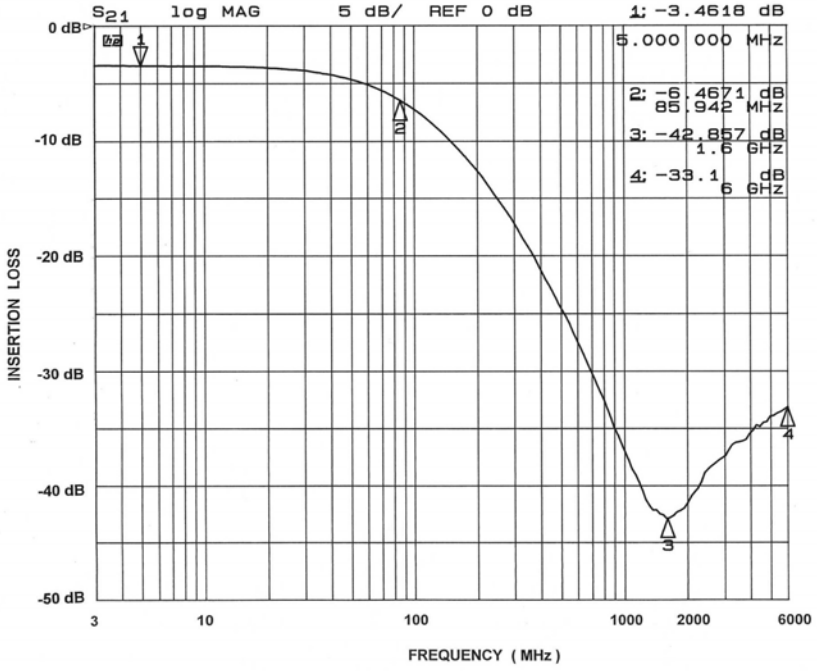

Figure 2. A2-C2 EMI Filter Performance

Performance Information (cont'd)

Typical Filter Performance (nominal conditions unless specified otherwise, 50 Ohm Environment)

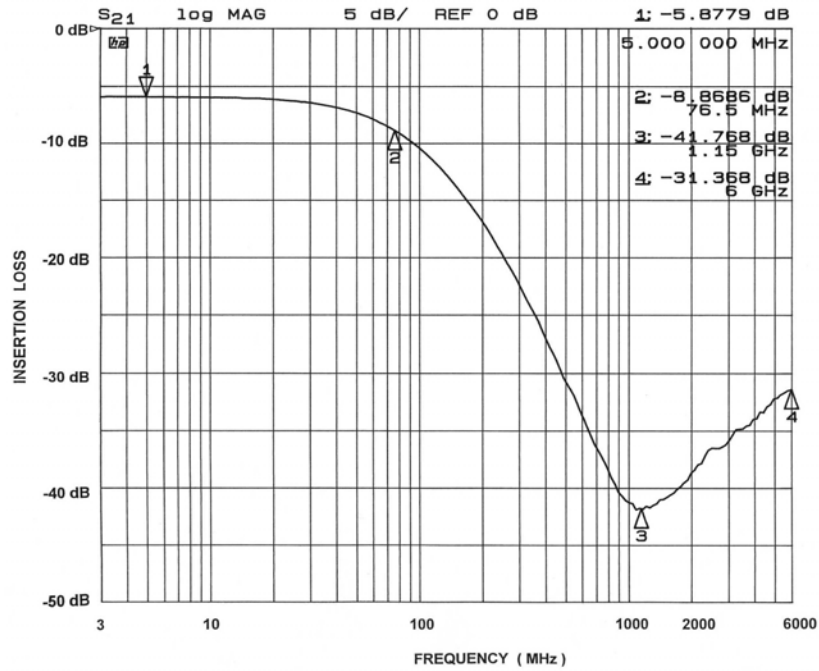

Figure 3. A3-C3 EMI Filter Performance

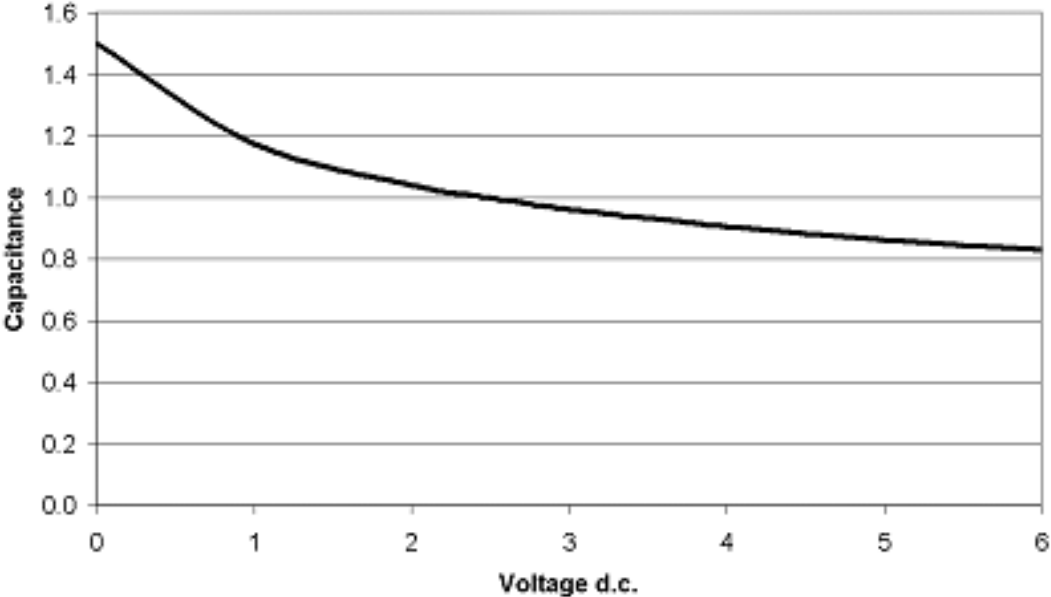
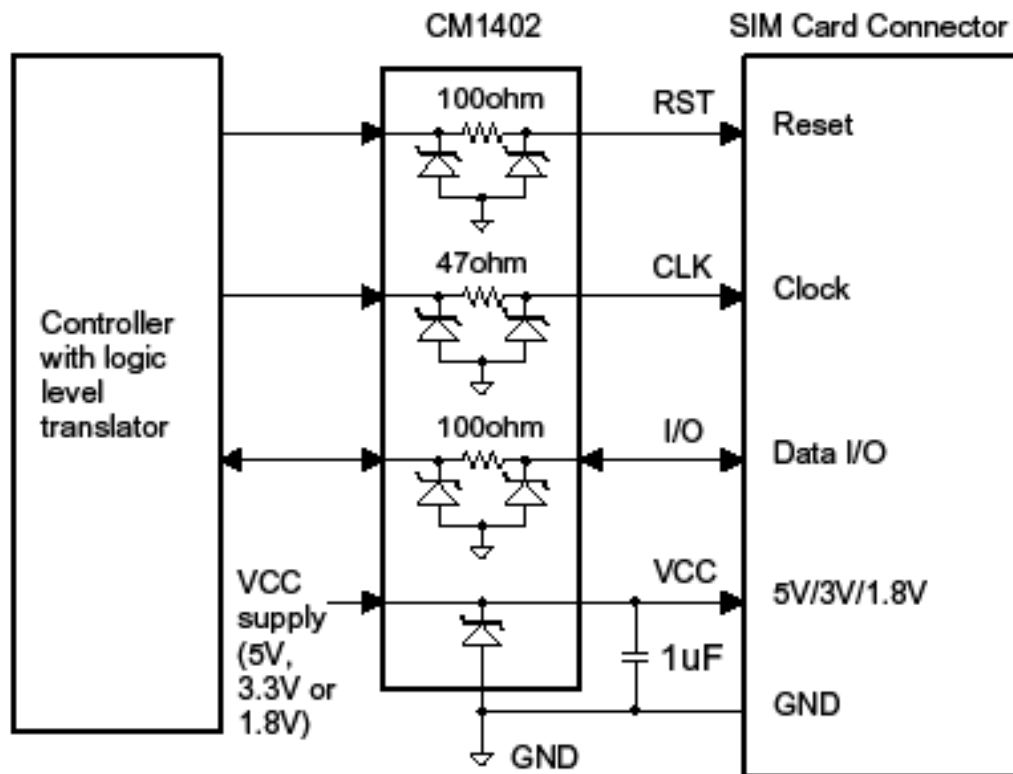

Figure 4. Typical Diode Capacitance vs. Input Voltage (normalized to 2.5VDC)

Application Information

The CM1402 provides a bidirectional filter and protector for all the signals and the power line on the SIM (subscriber identity module) card connector. SIM cards are found in all GSM cellular phones and in some other handheld devices or card readers. The ESD diodes protect the controller against possible ESD strikes that may occur when the connector pins are exposed during direct contact, or during insertion of the SIM card into the card slot. The EMI filter suppresses all high-frequency noise, preventing the unwanted EMI signals from both entering and exiting the main board. The signals that interface with the SIM card are the Reset, the Clock and the bidirectional data I/O, as shown in Typical Application Diagram for the SIM Card Interface.



Note: One channel of the CM1402 with a zener diode is not shown on the diagram.

Figure 5. Typical Application Diagram for the SIM Card Interface

For best filter and ESD performance, both GND bumps (B1, B2) of the CM1402 should be directly connected to the Ground plane. A small capacitor of about 1 μ F is required next to the V_{cc} pin of the SIM connector in order to improve stability of the SIM card supply rail.

Application Information

PARAMETER	VALUE
Pad Size on PCB	0.240mm
Pad Shape	Round
Pad Definition	Non-Solder Mask defined pads
Solder Mask Opening	0.290mm Round
Solder Stencil Thickness	0.125mm - 0.150mm
Solder Stencil Aperture Opening (laser cut, 5% tapered walls)	0.300mm Round
Solder Flux Ratio	50/50 by volume
Solder Paste Type	No Clean
Pad Protective Finish	OSP (Entek Cu Plus 106A)
Tolerance — Edge To Corner Ball	$\pm 50\mu\text{m}$
Solder Ball Side Coplanarity	$\pm 20\mu\text{m}$
Maximum Dwell Time Above Liquidous	60 seconds
Maximum Soldering Temperature for Lead-free Devices using a Lead-free Solder Paste	260°C

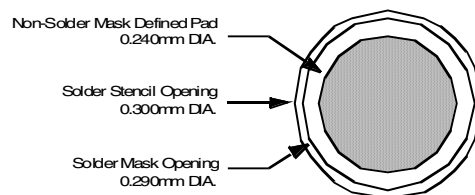

Figure 5. Recommended Non-Solder Mask Defined Pad Illustration

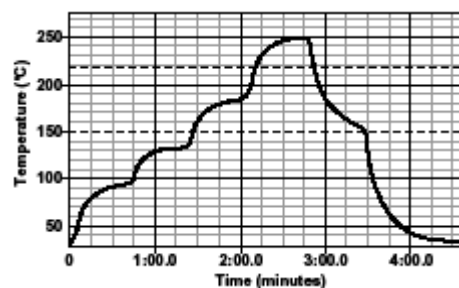

Figure 6. Lead-free (SnAgCu) Solder Ball Reflow Profile

CSP Mechanical Specifications

CM1402 devices are packaged in a custom Chip Scale Package (CSP). Dimensions are presented below. For complete information on CSP packaging, see the California Micro Devices CSP Package Information document.

Controlling dimension: millimeters

PACKAGE DIMENSIONS						
Package	Custom CSP					
Bumps	10					
Dim	Millimeters			Inches		
	Min	Nom	Max	Min	Nom	Max
A1	1.915	1.960	2.005	0.0754	0.0772	0.0789
A2	1.285	1.330	1.375	0.0506	0.0524	0.0541
B1	0.495	0.500	0.505	0.0195	0.0197	0.0199
B2	0.245	0.250	0.255	0.0096	0.0098	0.0100
B3	0.430	0.435	0.440	0.0169	0.0171	0.0173
B4	0.430	0.435	0.440	0.0169	0.0171	0.0173
C1	0.180	0.230	0.280	0.0071	0.0091	0.0110
C2	0.180	0.230	0.280	0.0071	0.0091	0.0110
D1	0.575	0.644	0.714	0.0226	0.0254	0.0281
D2	0.368	0.419	0.470	0.0145	0.0165	0.0185
# per tape and reel	3500 pieces					

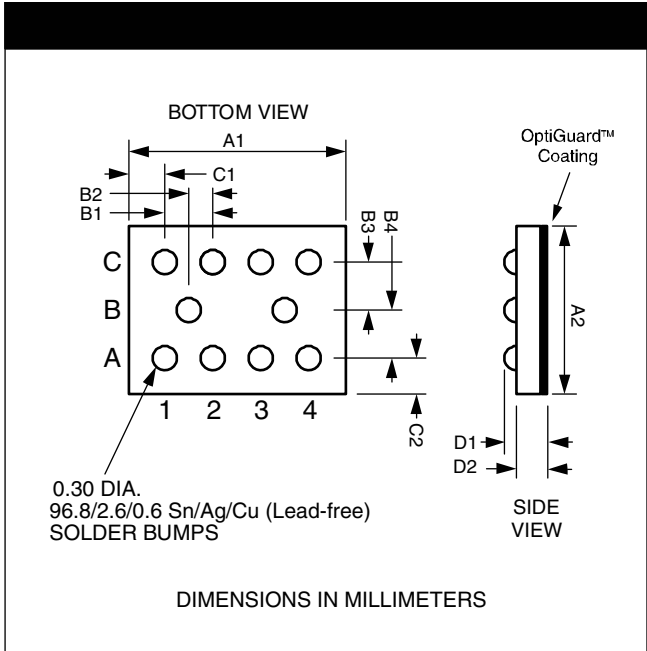

Package Dimensions for CM1402 Chip Scale Package

CSP Tape and Reel Specifications

PART NUMBER	CHIP SIZE (mm)	POCKET SIZE (mm) $B_0 \times A_0 \times K_0$	TAPE WIDTH W	REEL DIAMETER	QTY PER REEL	P_0	P_1
CM1402	1.96 X 1.33 X 0.644	2.08 X 1.45 X 0.711	8mm	178mm (7")	3500	4mm	4mm

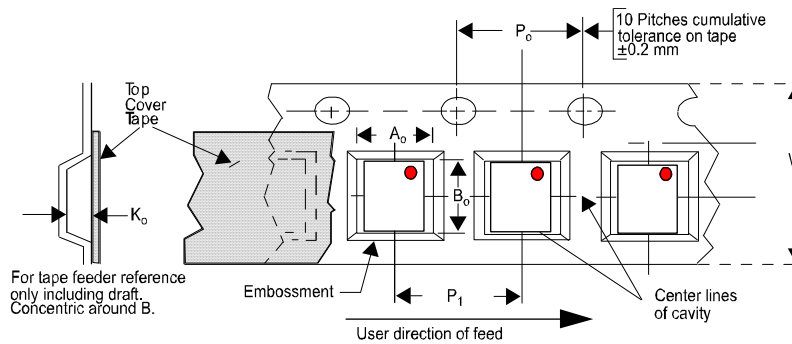



Figure 8. Tape and Reel Mechanical Data

ON Semiconductor and  are registered trademarks of Semiconductor Components Industries, LLC (SCILLC). SCILLC reserves the right to make changes without further notice to any products herein. SCILLC makes no warranty, representation or guarantee regarding the suitability of its products for any particular purpose, nor does SCILLC assume any liability arising out of the application or use of any product or circuit, and specifically disclaims any and all liability, including without limitation special, consequential or incidental damages. "Typical" parameters which may be provided in SCILLC data sheets and/or specifications can and do vary in different applications and actual performance may vary over time. All operating parameters, including "Typicals" must be validated for each customer application by customer's technical experts. SCILLC does not convey any license under its patent rights nor the rights of others. SCILLC products are not designed, intended, or authorized for use as components in systems intended for surgical implant into the body, or other applications intended to support or sustain life, or for any other application in which the failure of the SCILLC product could create a situation where personal injury or death may occur. Should Buyer purchase or use SCILLC products for any such unintended or unauthorized application, Buyer shall indemnify and hold SCILLC and its officers, employees, subsidiaries, affiliates, and distributors harmless against all claims, costs, damages, and expenses, and reasonable attorney fees arising out of, directly or indirectly, any claim of personal injury or death associated with such unintended or unauthorized use, even if such claim alleges that SCILLC was negligent regarding the design or manufacture of the part. SCILLC is an Equal Opportunity/Affirmative Action Employer. This literature is subject to all applicable copyright laws and is not for resale in any manner.

PUBLICATION ORDERING INFORMATION

LITERATURE FULFILLMENT:
Literature Distribution Center for ON Semiconductor
P.O. Box 5163, Denver, Colorado 80217 USA
Phone: 303-675-2175 or 800-344-3860 Toll Free USA/Canada
Fax: 303-675-2176 or 800-344-3867 Toll Free USA/Canada
Email: orderlit@onsemi.com

N. American Technical Support: 800-282-9855
Toll Free USA/Canada
Europe, Middle East and Africa Technical Support:
Phone: 421 33 790 2910
Japan Customer Focus Center
Phone: 81-3-5773-3850

ON Semiconductor Website: www.onsemi.com
Order Literature: <http://www.onsemi.com/orderlit>
For additional information, please contact your local Sales Representative

Данный компонент на территории Российской Федерации

Вы можете приобрести в компании MosChip.

Для оперативного оформления запроса Вам необходимо перейти по данной ссылке:

<http://moschip.ru/get-element>

Вы можете разместить у нас заказ для любого Вашего проекта, будь то серийное производство или разработка единичного прибора.

В нашем ассортименте представлены ведущие мировые производители активных и пассивных электронных компонентов.

Нашей специализацией является поставка электронной компонентной базы двойного назначения, продукции таких производителей как XILINX, Intel (ex.ALTERA), Vicor, Microchip, Texas Instruments, Analog Devices, Mini-Circuits, Amphenol, Glenair.

Сотрудничество с глобальными дистрибьюторами электронных компонентов, предоставляет возможность заказывать и получать с международных складов практически любой перечень компонентов в оптимальные для Вас сроки.

На всех этапах разработки и производства наши партнеры могут получить квалифицированную поддержку опытных инженеров.

Система менеджмента качества компании отвечает требованиям в соответствии с ГОСТ Р ИСО 9001, ГОСТ РВ 0015-002 и ЭС РД 009

Офис по работе с юридическими лицами:

105318, г.Москва, ул.Щербаковская д.3, офис 1107, 1118, ДЦ «Щербаковский»

Телефон: +7 495 668-12-70 (многоканальный)

Факс: +7 495 668-12-70 (доб.304)

E-mail: info@moschip.ru

Skype отдела продаж:

moschip.ru

moschip.ru_4

moschip.ru_6

moschip.ru_9