

## VIDEO ON-SCREEN DISPLAY

### ■ GENERAL DESCRIPTION

The **NJM2214** is a video display convertive integrated circuit. Its function is below.

- Character superimpose.
- 8 color generating function.
- Luminance signal wave shape-up function.
- Video effecter function of painting to background superimposed character or some part of video signal.

### ■ FEATURES

- Operating Voltage (+4.7V to +5.3V)
- Internal 8 Color Generating Circuit.
- Package Outline SDIP22, DMP24
- Bipolar Technology

### ■ RECOMMENDED OPERATING CONDITION

- Operating Voltage 4.7 to 5.3V

### ■ APPLICATION

- VCR, Video Camera

### ■ PACKAGE OUTLINE

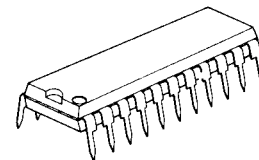

**NJM2214L**

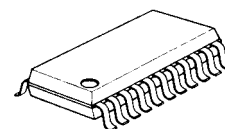

**NJM2214M**

# NJM2214

## ■ ABSOLUTE MAXIMUM RATINGS

( $T_a=25^\circ$ )

PARAMETER	SYMBOL	RATINGS	UNIT
Supply Voltage	$V^+$	10	V
Power Dissipation	$P_D$	(SDIP22) 700 (DMP24) 700	mW
Operating Temperature Range	$T_{opr}$	-20 to +75	$^\circ\text{C}$
Storage Temperature Range	$T_{stg}$	-40 to +125	$^\circ\text{C}$

## ■ ELECTRICAL CHARACTERISTICS

( $T_a=25^\circ$ ,  $V^+=5\text{V}$ )

PARAMETER	SYMBOL	TEST CONDITION	MIN.	TYP.	MAX.	UNIT
Operating Current	$I_{CC}$	No signal, No load	17	25	33	mA
Video Switch Voltage Gain	$G_V$	10, 11, 15, 22 (11, 12, 17) Pin=Low 10STEP Stair wave, 2.2V <sub>P-P</sub> , R1=5K	-1	0	+1	dB
Frequency Characteristics	$G_F$	10, 11, 15, 22 (11, 12, 17) Pin=Low 2V <sub>P-P</sub> , 4MHz, R1=5K	-1	0	+1	dB
Differential Gain	DG	10, 11, 15, 22 (11, 12, 17) Pin=Low 10STEP Stair wave, 2.2V <sub>P-P</sub> , R1=5K	-3	0	+3	%
Differential Phase	DP	10STEP Stair wave, 2.2V <sub>P-P</sub> , R1=5K	-3	0	+3	degree
8 Color Output		15 (17) Pin=High, 10, 11, 22 (11, 12) Pin=Low (Note)				
White	Amplitude	$C_{1A}$	-	0	100	mV <sub>P-P</sub>
	Luminance	$C_{1D}$	1.56	1.66	1.76	V
	Phase	$C_{1P}$	-	-	-	degree
Yellow	Amplitude	$C_{2A}$	810	900	990	mV <sub>P-P</sub>
	Luminance	$C_{2D}$	1.45	1.55	1.65	V
	Phase	$C_{2P}$	Phase : Ref. to Yellow	-10	0	10
Cyan	Amplitude	$C_{3A}$	1160	1290	1420	mV <sub>P-P</sub>
	Luminance	$C_{3D}$	1.26	1.36	1.46	V
	Phase	$C_{3P}$		106	116	126

( ) : DMP

## ■ ELECTRICAL CHARACTERISTICS

( $T_a=25^\circ$ ,  $V^+=5V$ )

PARAMETER		SYMBOL	TEST CONDITION	MIN.	TYP.	MAX.	UNIT
Green	Amplitude	$C_{4A}$		1080	1200	1320	mV <sub>P-P</sub>
	Luminance	$C_{4D}$		1.14	1.24	1.34	V
	Phase	$C_{4P}$		63	73	83	degree
Magenta	Amplitude	$C_{5A}$		1080	1200	1320	mV <sub>P-P</sub>
	Luminance	$C_{5D}$		0.96	1.06	1.16	V
	Phase	$C_{5P}$		243	253	263	degree
Red	Amplitude	$C_{6A}$		1160	1290	1420	mV <sub>P-P</sub>
	Luminance	$C_{6D}$		0.85	0.95	1.05	V
	Phase	$C_{6P}$		286	296	306	degree
Blue	Amplitude	$C_{7A}$		810	900	990	mV <sub>P-P</sub>
	Luminance	$C_{7D}$		0.66	0.76	0.86	V
	Phase	$C_{7P}$		170	180	190	degree
Black	Amplitude	$C_{8A}$		-	0	100	mV <sub>P-P</sub>
	Luminance	$C_{8D}$		0.54	0.64	0.74	V
	Phase	$C_{8P}$		-	-	-	degree
Blanking Pulse Input Threshold Voltage		$V_{TH-19}$	Pin 19 (21)	1.0	1.5	2.0	V
HD		$V_{TH-18}$	Pin 18 (20)	1.0	1.5	2.0	V
Invert		$V_{TH-11}$	Pin 11 (12)	1.0	1.5	2.0	V
2 Value Selection		$V_{TH-10}$	Pin 10 (11)	1.0	1.5	2.0	V
Background ON/OFF		$V_{TH-15}$	Pin 15 (17)	1.0	1.5	2.0	V
Matrix 1		$V_{TH-M1}$	Pin 1 (1)	3.3	3.9	4.5	V
Matrix 2		$V_{TH-M2}$	Pin 2 (2)	3.3	3.9	4.5	V
Matrix 3		$V_{TH-M3}$	Pin 3 (3)	3.3	3.9	4.5	V
Character Input		$V_{TH-21}$	Pin 21 (23)	0.5	1.0	1.5	V
EXT/Character Selection		$V_{TH-20}$	Pin 20 (22)	1.0	1.5	2.0	V

( ) : DMP

(Note) :  $f_{SC1}, f_{SC2}=3.58\text{MHz}$ ,  $300\text{mV}_{PP}$   
 $f_{SC1}$ , =same phase of color burst signal.  
 $f_{SC2}$ , =90 degree phase lag from  $f_{SC1}$ .

# NJM2214

## ■ RELATION BETWEEN 8 COLOR OUTPUT AND MATRIX INPUT

COLOR	MATRIX 1	MATRIX 2	MATRIX 3
White	L	L	L
Yellow	H	L	L
Cyan	L	H	L
Green	H	H	L
Magenta	L	L	H
Red	H	L	H
Blue	L	H	H
Black	H	H	H

L=0V (DC)

H=5V (DC)

## ■ CONTROL SIGNAL AND FUNCTION

15 PIN	10 PIN	11 PIN	20 PIN	
L	L/H	L	L	Character superimposer (White/Black) on video through signal output.
H	L/H	L	L	Character superimposer (White/Black) on background (8 color).
H	L/H	H	L	Character superimposer (color) on background (White/Black).
L	L	H	L	Character superimposer (color) on video through signal.
L	L/H	L	H	Luminance modification. Strong bright point is White/Black.
H	L/H	L	H	Colored except strong bright point.
H	L/H	H	H	Colored at strong bright point and others is White/Black.
L	H	H	H	Colored at strong bright point and others is video through.



# NJM2214

## ■ APPLICATION

This IC requires  $1M\Omega$  resistance between INPUT and GND pin for clamp type input since the minute current causes an unstable pin voltage.

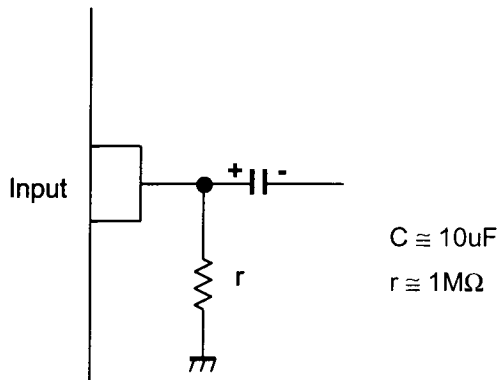

**[CAUTION]**

The specifications on this databook are only given for information, without any guarantee as regards either mistakes or omissions. The application circuits in this databook are described only to show representative usages of the product and not intended for the guarantee or permission of any right including the industrial rights.

# Mouser Electronics

Authorized Distributor

Click to View Pricing, Inventory, Delivery & Lifecycle Information:

[NJR:](#)

[NJM2214M](#) [NJM2214L](#)

## Данный компонент на территории Российской Федерации

### Вы можете приобрести в компании MosChip.

Для оперативного оформления запроса Вам необходимо перейти по данной ссылке:

<http://moschip.ru/get-element>

Вы можете разместить у нас заказ для любого Вашего проекта, будь то серийное производство или разработка единичного прибора.

В нашем ассортименте представлены ведущие мировые производители активных и пассивных электронных компонентов.

Нашей специализацией является поставка электронной компонентной базы двойного назначения, продукции таких производителей как XILINX, Intel (ex.ALTERA), Vicor, Microchip, Texas Instruments, Analog Devices, Mini-Circuits, Amphenol, Glenair.

Сотрудничество с глобальными дистрибьюторами электронных компонентов, предоставляет возможность заказывать и получать с международных складов практически любой перечень компонентов в оптимальные для Вас сроки.

На всех этапах разработки и производства наши партнеры могут получить квалифицированную поддержку опытных инженеров.

Система менеджмента качества компании отвечает требованиям в соответствии с ГОСТ Р ИСО 9001, ГОСТ РВ 0015-002 и ЭС РД 009

### Офис по работе с юридическими лицами:

105318, г.Москва, ул.Щербаковская д.3, офис 1107, 1118, ДЦ «Щербаковский»

Телефон: +7 495 668-12-70 (многоканальный)

Факс: +7 495 668-12-70 (доб.304)

E-mail: [info@moschip.ru](mailto:info@moschip.ru)

Skype отдела продаж:

moschip.ru

moschip.ru\_4

moschip.ru\_6

moschip.ru\_9