

Continuous Rotation Servo (#900-00008)

General Information

The Parallax Continuous Rotation servo is ideal for robotic products that need a geared wheel drive or other projects that require a 360 degree rotation geared motor. The Parallax Continuous Rotation servo output gear shaft is a standard Futaba configuration. The servo can be adjusted with a small Phillips screw driver if the unit becomes out adjustment on its center set point. Servo is custom manufactured for Parallax by Futaba.



Technical Specifications

- > Power 6vdc max
- > Average Speed 60 rpm
Note: with 5vdc and no torque
- > Weight 45.0 grams/1.59oz
- > Torque 3.40 kg-cm/47oz-in
- > Size mm (L x W x H)
40.5x20.0x38.0
- > Size in (L x W x H)
1.60x.79x1.50
- > Manual adjustment port

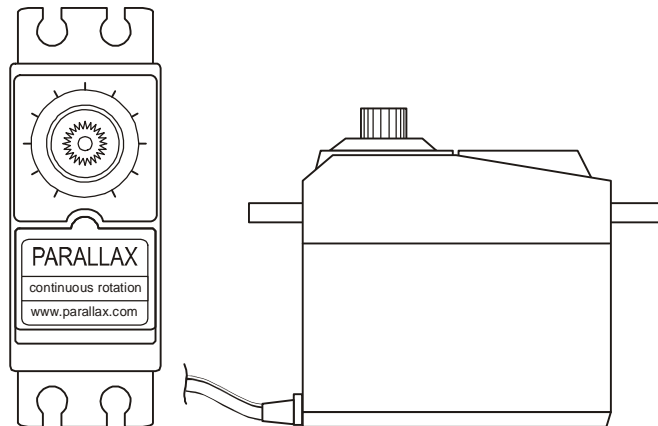

Adjusting the set point for the servo

Using a Parallax screwdriver or an (0x40) size Phillips screw driver. Program the BASIC Stamp® microcontroller you are using with one of the following codes or setup your pulse generator to 1.5 ms at 20ms intervals. Once the pulses are generated and the servo is powered and connected. Insert the Phillips side of your screw driver in to the adjustment port. Once inserted you should be able to turn the internal potentiometer to the left and right. You should see the servo change direction also to the left and right. If not make sure you are making contact with the potentiometer. **Warning: do not press too hard you may do permanent damage to the servo.** To adjust the potentiometer turn to the left/right until the servo stops turning. Be sure to adjust the potentiometer slowly to in sure you do not pass the set point. If you do pass it the servo will change direction.

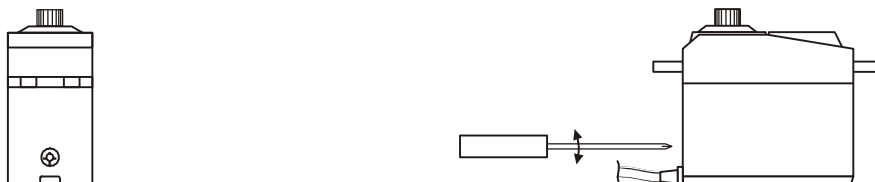

BASIC Stamp 1 code

```
SYMBOL Servo_pin = 0  
  
Start:  
  PULSOUT Servo_pin,150  
  PAUSE 20  
GOTO Start
```

BASIC Stamp 2,2e,2ep code

```
Servo_pin CON 0  
  
Start:  
  PULSOUT Servo_pin,750  
  PAUSE 20  
goto Start
```

BASIC Stamp 2sx,2p24,2p40 code

```
Servo_pin CON 0  
Start:  
  PULSOUT Servo_pin,1875  
  PAUSE 20  
GOTO Start
```

Servo Control from a BASIC Stamp microcontroller

Parallax (www.parallax.com) publishes many circuits and examples to control servos. Most of these examples are available for download from our web site. On www.parallax.com type in "servo" and you'll find example codes below.

Wiring setup

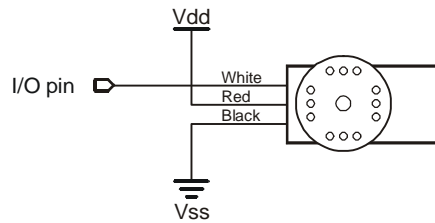

The servo is controlled by pulsing of its signal line. If you are using a Basic Stamp® microcontroller this is done with the 'pulsout' command. Below is PBASIC code that will help you with basic control of a servo. The code below will show center and then rotate the servo to the left and to the right then stop.

Basic Stamp 1 code

```

SYMBOL Temp = W0           'Work space for FOR NEXT
SYMBOL Servo_pin = 0       'I/O pin that is connected to servo

FOR temp = 0 TO 200 '
PULSOUT Servo_pin,150
PAUSE 20
NEXT

FOR temp = 0 TO 200
PULSOUT Servo_pin,180
PAUSE 20
NEXT

FOR temp = 0 TO 200
PULSOUT Servo_pin,120
PAUSE 20
NEXT
Stop

```

BASIC Stamp 2, 2e,2pe code

```

Temp      VAR      Word  'Work space for FOR NEXT
Servo_pin CON      0     'I/O pin that is connected to servo

FOR temp = 0 TO 200
PULSOUT servo_pin,750
PAUSE 20
NEXT

FOR temp = 0 TO 200
PULSOUT servo_pin,900
PAUSE 20
NEXT

FOR temp = 0 TO 200
PULSOUT servo_pin,600
PAUSE 20
NEXT
STOP

```

BASIC Stamp 2sx,2p24/40 code

```

Temp      VAR      Word  'Work space for FOR NEXT
Servo_pin CON      0     'I/O pin that is connected to servo

for temp = 0 to 200
pulsout Servo_pin,1875
pause 20
next

for temp = 0 to 200
pulsout Servo_pin,2250
pause 20
next

for temp = 0 to 200
pulsout Servo_pin,1500
pause 20
next
STOP

```

Данный компонент на территории Российской Федерации

Вы можете приобрести в компании MosChip.

Для оперативного оформления запроса Вам необходимо перейти по данной ссылке:

<http://moschip.ru/get-element>

Вы можете разместить у нас заказ для любого Вашего проекта, будь то серийное производство или разработка единичного прибора.

В нашем ассортименте представлены ведущие мировые производители активных и пассивных электронных компонентов.

Нашей специализацией является поставка электронной компонентной базы двойного назначения, продукции таких производителей как XILINX, Intel (ex.ALTERA), Vicor, Microchip, Texas Instruments, Analog Devices, Mini-Circuits, Amphenol, Glenair.

Сотрудничество с глобальными дистрибьюторами электронных компонентов, предоставляет возможность заказывать и получать с международных складов практически любой перечень компонентов в оптимальные для Вас сроки.

На всех этапах разработки и производства наши партнеры могут получить квалифицированную поддержку опытных инженеров.

Система менеджмента качества компании отвечает требованиям в соответствии с ГОСТ Р ИСО 9001, ГОСТ РВ 0015-002 и ЭС РД 009

Офис по работе с юридическими лицами:

105318, г.Москва, ул.Щербаковская д.3, офис 1107, 1118, ДЦ «Щербаковский»

Телефон: +7 495 668-12-70 (многоканальный)

Факс: +7 495 668-12-70 (доб.304)

E-mail: info@moschip.ru

Skype отдела продаж:

moschip.ru

moschip.ru_4

moschip.ru_6

moschip.ru_9