

# D-sub Connectors XM3/XM2S

## The D-sub Connector are Ideal for Office Automation Interfacing

- Shielded against EMI.
- Multi-hole, ferrite-core Connectors (XM3B-F) offers space-saving design and superior noise protection at high frequency.
- Rugged, compact, metallized plastic hood (XM2S) provides excellent noise protection.
- Conforms to UL standards. (No. E103202) (XM2S hoods and other models not included.)
- Available with many kinds of standard Anchors and grounding fixtures.
- RoHS Compliant.

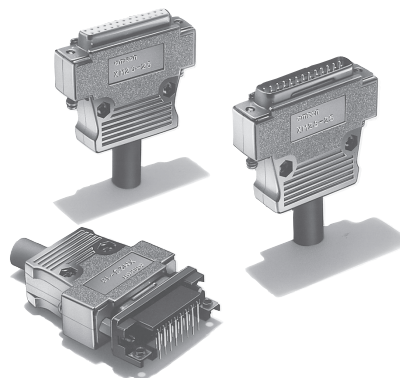

## Connectors and Hoods

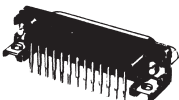
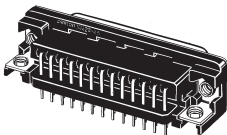
Model	XM3B	XM3B-F
Type	Sockets with Right-angle DIP Terminals	Sockets with Right-angle DIP Terminals and ferrite core
Appearance		

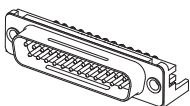
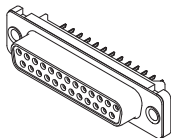
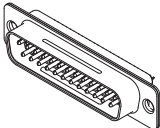
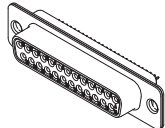
Model	XM3C	XM3F	XM3A	XM3D
Type	Plugs with Right-angle DIP Terminals	Sockets with Straight DIP Terminals	Plugs with Solder Cup Terminals	Sockets with Solder Cup Terminals
Appearance				

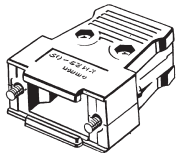
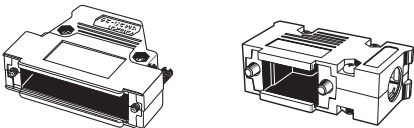
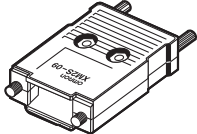
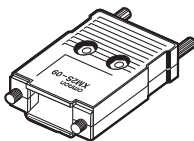
Model	XM2S		XM2S-E
Type	Straight Cable Connection Metallized Plastic	Right Angle Cable Connection Metallized Plastic for 9 and 25 terminal models	Straight Cable Connection, with ESD Production for 9 terminal models
Appearance		 	

## ■ Ratings and Characteristics

	XM3A, XM3B, XM3B-F, XM3C (except 37 terminal models), XM3D, XM3F	XM3C - 37 terminal models	XM2S, XM2S-E (Hoods)
Rated current	5 A	3 A	---
Rated voltage	300 VAC		
Contact resistance	15 mΩ max. (at 20 mV, 100 mA max.)		
Insulation resistance	1,000 MΩ min. (at 500 VDC)		
Dielectric strength	1,000 VAC for 1 min. (leakage current: 1 mA max.)		
Total insertion force	Number of terminals x 3.33 N max.		
Removal force	0.29 N min. (for gauge diameter of 0.99 mm)		
Insertion Durability	200 times		
Ambient operating temperature	-55°C to 105°C (with no icing)		-25°C to 85°C
Shield performance	Mounted in panel: 25 dB min. (30 to 900 MHz) Mounted on board: 20 dB min. (30 to 900 MHz)		---

## ■ Materials and Finish

### Connectors

	XM3B	XM3B-F	XM3C	XM3F	XM3A	XM3D
Housing	Fiber-glass reinforced PBT resin (UL94V-0)/black				Fiber-glass reinforced PBT resin (UL94V-0)/Milky white	
Contacts	Mating End	Phosphor Bronze / Nickel base, gold plated (0.4 μm)			Bronze / Nickel base, gold plated (0.4 μm)	Phosphor Bronze / Nickel base, gold plated (0.4 μm)
	Terminals	Phosphor Bronze / Nickel base, tin plated (2 μm)	Phosphor Bronze / Nickel base, tin plated (3 μm)		Bronze / Nickel base, tin plated (3 μm)	Phosphor Bronze / Nickel base, tin plated (3 μm)
Shell	Steel. Nickel plated					

### Hoods

	XM2S		XM2S-E
	Straight Connecting Cable	Right-angle Connecting Cable	Straight Connecting Cable with ESD Protection
Housing	ABS resin / nickel plated		ABS resin
Cable clamp	Steel / nickel plated		
Lock screw (Driver type)	Steel / nickel plated	---	---
Lock screw (Jackscrew)	Brass / nickel plated (See note)	Brass / nickel plated	Fiber-glass reinforced polyamide (UL94V-0)/black

**Note:** Jackscrews (thumbscrews) for the straight, non-ESD version of the XM2S hood are sold separately. See "Accessories" section of this datasheet.

## ■ Applicable Wires

The applicable wires for solder cup terminals are AWG 22 to 28 (solid or stranded).

# XM3B Sockets with Right-angle DIP Terminals

## Dimensions

XM3B-□□22-□□□

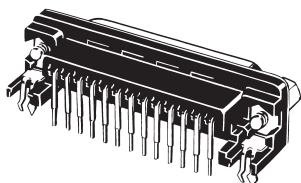

25-contact model shown above.  
(With anchor 2, Lock Pin, Grounding Fixtures)

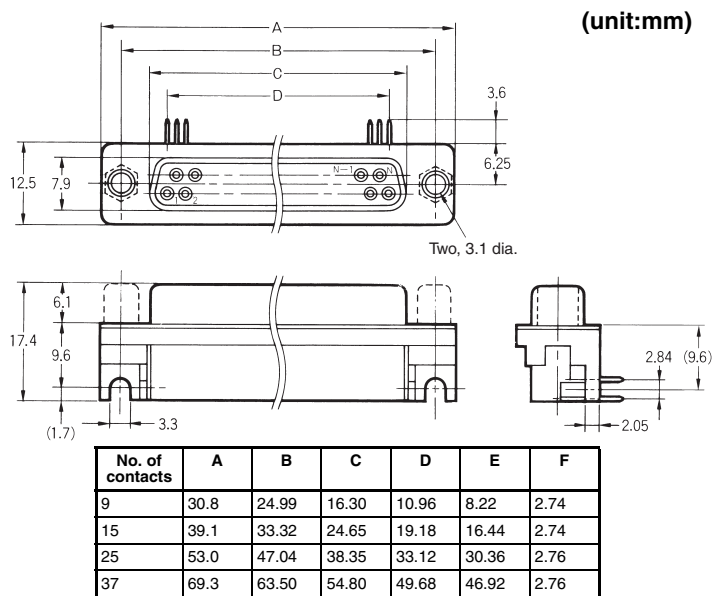
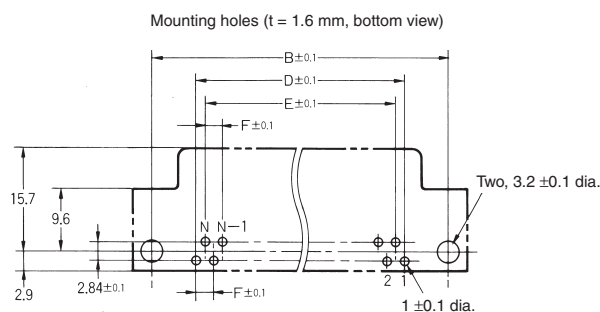

**Note:** XM3B Sockets were manufactured in accordance with JIS X 5101. Terminal pitches are a mixed arrangement of 2.77 and 2.74 mm contacts on 25 and 37 contact models as specified in the JIS standard. A pitch of 2.76 mm is recommended for the mounting holes because of the more advanced numerical control available today. This is sufficient to avoid any problems.

## Ordering Information

Appearance				
	Tap Hole Grounding Fixture		Lock Pin Grounding Fixture	
Accessories	XM2Z-0011 Anchor 2 (M2.6 x 0.45 metric screws)	XM2Z-0013 Anchor 2 (#4-40 UNC inch screws)	XM2Z-0011 Anchor 2 (M2.6 x 0.45 metric screws)	XM2Z-0013 Anchor 2 (#4-40 UNC inch screws)
No. of contacts	XM2Z-0061 Tap Hole Grounding Fixtures		XM2Z-0062 Lock Pin Grounding Fixtures	
9	XM3B-0922-111	XM3B-0922-131	XM3B-0922-112	XM3B-0922-132
15	XM3B-1522-111	XM3B-1522-131	XM3B-1522-112	XM3B-1522-132
25	XM3B-2522-111	XM3B-2522-131	XM3B-2522-112	XM3B-2522-132
37	XM3B-3722-111	XM3B-3722-131	XM3B-3722-112	XM3B-3722-132

Appearance			
	Tap Hole Grounding Fixture		
Accessories	Lock Pin Grounding Fixture		
No. of contacts	No anchors		
	---	XM2Z-0061 Tap Hole Grounding Fixtures	XM2Z-0062 Lock Pin Grounding Fixtures
9	XM3B-0922	XM3B-0922-501	XM3B-0922-502
15	XM3B-1522	XM3B-1522-501	XM3B-1522-502
25	XM3B-2522	XM3B-2522-501	XM3B-2522-502
37	XM3B-3722	XM3B-3722-501	XM3B-3722-502

**Note:** 1. Use the XM3B-□□22 (No anchors or grounding fixtures) in combination with suitable Anchors and Grounding Fixtures.  
2. Two M3 x 0.5 Tap Hole Grounding Fixtures and an M3 x 0.5 Lock Pin Grounding Fixture for the Anchor Side are provided.

# XM3B-F Sockets with Right-angle DIP Terminals and Ferrite Cores

## Dimensions

XM3B-□□22-501F

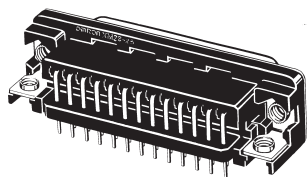

25-contact model shown above.  
(With Tap Hole Grounding Fixtures)

(unit:mm)

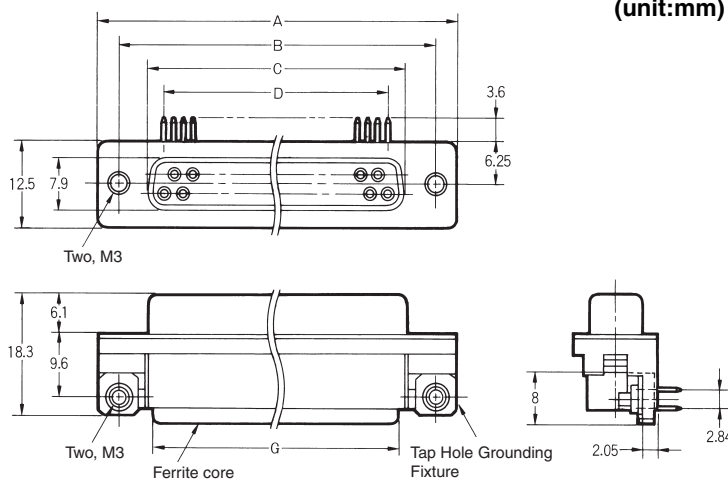

Mounting holes (t = 1.6 mm, bottom view)

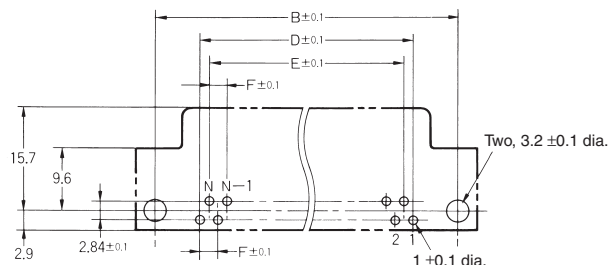

No. of contacts	A	B	C	D	E	F	G
9	30.8	24.99	16.30	10.96	8.22	2.74	14.3
15	39.1	33.32	24.65	19.18	16.44	2.74	22.0
25	53.0	47.04	38.35	33.12	30.36	2.76	36.5
37	69.3	63.50	54.80	49.68	46.92	2.76	53.3

**Note:** XM3B Sockets were manufactured in accordance with JIS X 5101. Terminal pitches are a mixed arrangement of 2.77 and 2.74 mm contacts on 25 and 37 contact models as specified in the JIS standard. A pitch of 2.76 mm is recommended for the mounting holes because of the more advanced numerical control available today. This is sufficient to avoid any problems.

## Ordering Information

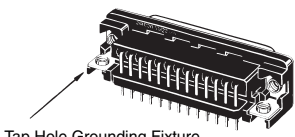
Appearance	
	Tap Hole Grounding Fixture
Accessories	XM2Z-0061 Tap Hole Grounding Fixtures
No. of contacts	
9	XM3B-0922-501F
15	XM3B-1522-501F
25	XM3B-2522-501F
37	XM3B-3722-501F

# XM3C Plugs with Right-angle DIP Terminals

## Dimensions

XM3C-□□22-□□□

(unit:mm)

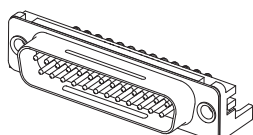

25-contact model shown above.  
(No Anchor or Grounding Fixtures)

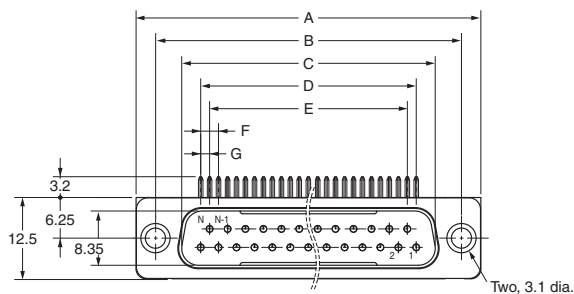

Two, 3.1 dia.

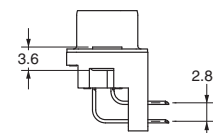
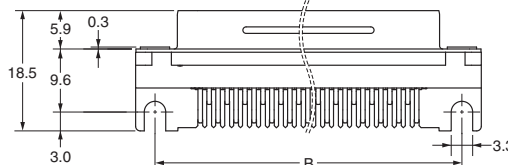
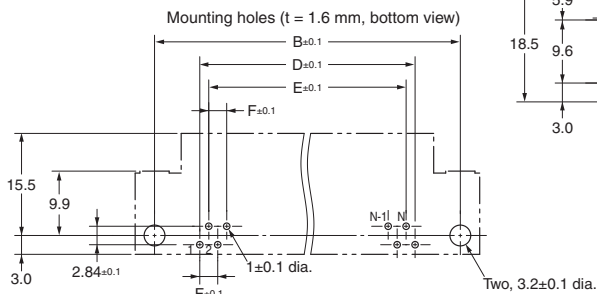

No. of contacts	A	B	C	D	E	F	G
9	30.8	24.99	16.91	10.96	8.22	2.74	1.37
15	39.1	33.32	25.25	19.18	16.44	2.74	1.37
25	53.0	47.04	38.96	33.12	30.36	2.76	1.38
37	69.3	63.50	55.42	49.68	46.92	2.76	1.38

**Note:** XM3C Sockets were manufactured in accordance with JIS X 5101. Terminal pitches are a mixed arrangement of 2.77 and 2.74 mm contacts on 25 and 37 contact models as specified in the JIS standard. A pitch of 2.76 mm is recommended for the mounting holes because of the more advanced numerical control available today. This is sufficient to avoid any problems.

## Ordering Information

Appearance		
Accessories	<b>XM2Z-0011 Anchor 2 (M2.6 × 0.45 metric screws)</b>	
No. of contacts	Tap Hole Grounding Fixtures	Lock Pin Grounding Fixtures
9	XM3C-0922-111	XM3C-0922-112
15	XM3C-1522-111	XM3C-1522-112
25	XM3C-2522-111	XM3C-2522-112
37	XM3C-3722-111	XM3C-3722-112

Appearance			
Accessories	<b>No anchors</b>		
No. of contacts	---	Tap Hole Grounding Fixtures	Lock Pin Grounding Fixtures
9	XM3C-0922	XM3C-0922-501	XM3C-0922-502
15	XM3C-1522	XM3C-1522-501	XM3C-1522-502
25	XM3C-2522	XM3C-2522-501	XM3C-2522-502
37	XM3C-3722	XM3C-3722-501	XM3C-3722-502

**Note:** 1. Use the XM3C-□□22 (No anchors or grounding fixtures) in combination with suitable Anchors and Grounding Fixtures.  
 2. Two M3 x 0.5 Tap Hole Grounding Fixtures and an M3 x 0.5 Lock Pin Grounding Fixture for the Anchor Side are provided.  
 3. XM3C-□□22-□3□ versions with Inch Screws are also available.

# XM3F Sockets with Straight DIP Terminals

## Dimensions

XM3F-□□20

XM3F-□□20-112

(unit:mm)

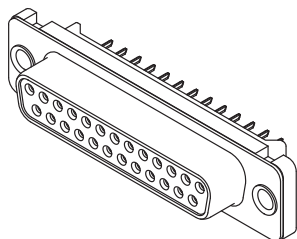

25-contact model shown on the left.  
(No anchors or grounding fixtures)

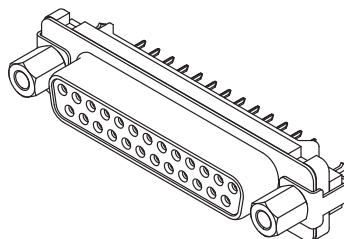

25-contact model shown on the left.  
(With Anchors and Grounding Fixtures)

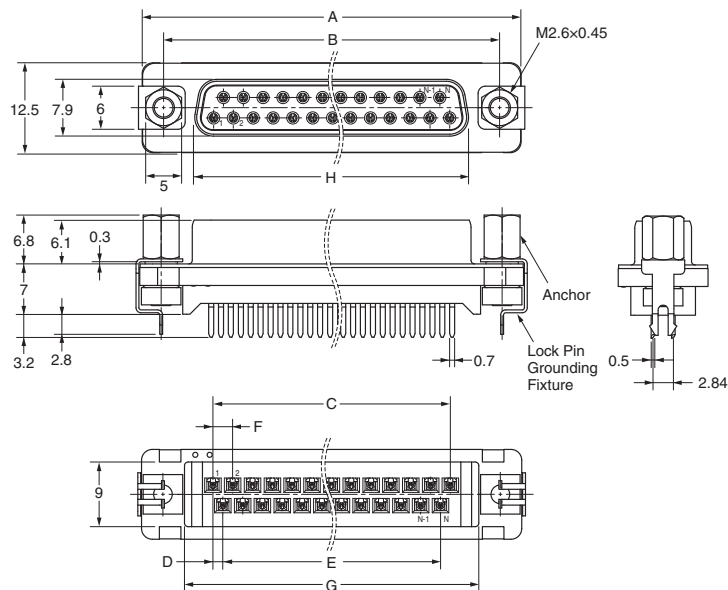
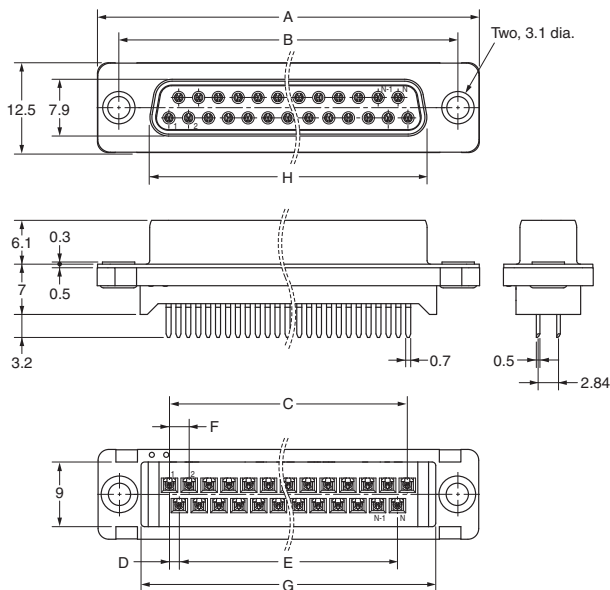

Mounting holes (t = 1.6 mm, bottom view)

No. of contacts	A	B	C	D	E	F	G	H
9	30.7	24.99	10.98	1.37	8.22	2.74	19.00	16.33
15	39.0	33.32	19.20	1.37	16.44	2.74	27.12	24.66
25	52.9	47.04	33.12	1.38	30.36	2.76	41.04	38.38
37	69.2	63.50	49.68	1.38	46.92	2.76	57.60	54.84

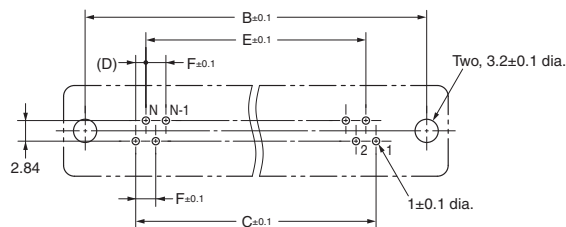

## Ordering Information

No. of contacts	Appearance	
	No anchors or Grounding Fixtures	Anchors and Lock Pin Grounding Fixtures
9	XM3F-0920	XM3F-0920-112
15	XM3F-1520	XM3F-1520-112
25	XM3F-2520	XM3F-2520-112
37	XM3F-3720	XM3F-3720-112

# XM3A Plugs with Solder-cup Terminals

# XM3D Sockets with Solder-cup Terminals

## Dimensions

XM3A-□□21

(unit:mm)

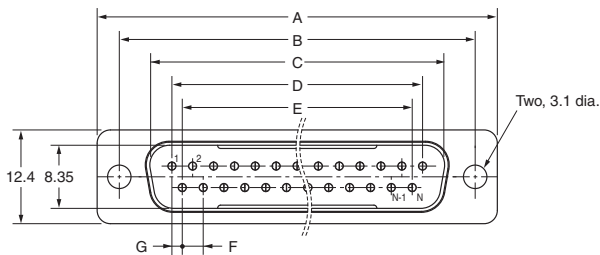
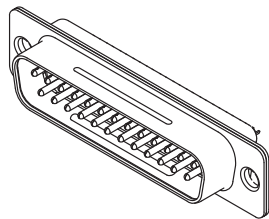

Note: 25-contact model shown above.

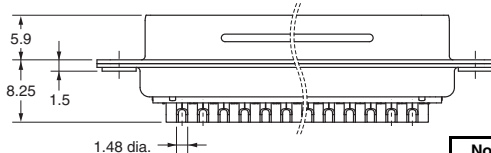

No. of contacts	A	B	C	D	E	F	G
9	30.7	24.99	16.91	10.96	8.22	2.74	1.37
15	39.0	33.32	25.25	19.18	16.44	2.74	1.37
25	52.9	47.04	38.96	33.12	30.36	2.76	1.38
37	69.2	63.50	55.42	49.68	46.92	2.76	1.38

XM3D-□□21

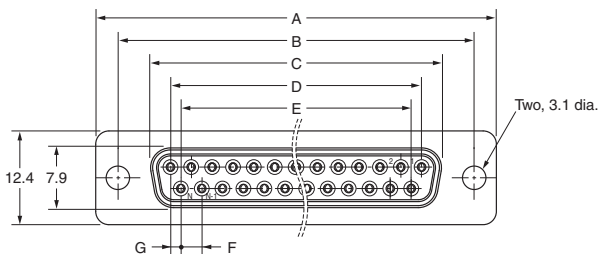
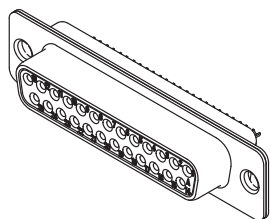

Note: 25-contact model shown above.

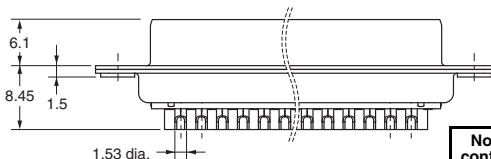

No. of contacts	A	B	C	D	E	F	G
9	30.7	24.99	16.33	10.96	8.22	2.74	1.37
15	39.0	33.32	24.66	19.18	16.44	2.74	1.37
25	52.9	47.04	38.38	33.12	30.36	2.76	1.38
37	69.2	63.50	54.84	49.68	46.92	2.76	1.38

## Ordering Information

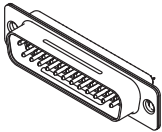
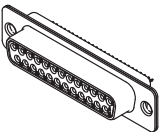
Appearance	Plugs	Sockets
		
No. of contacts		
9	XM3A-0921	XM3D-0921
15	XM3A-1521	XM3D-1521
25	XM3A-2521	XM3D-2521
37	XM3A-3721	XM3D-3721

# XM2S / XM2S-E Straight and Right Angle Hoods

## Dimensions

9-contact Hood  
with Straight Connecting Cable  
XM2S-091□

(unit:mm)

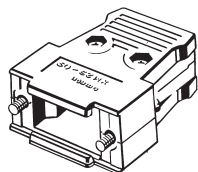

9-contact Hood

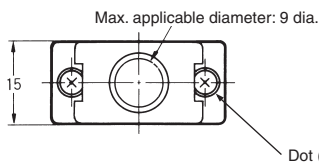

15, 25 and 37-Contact Hoods

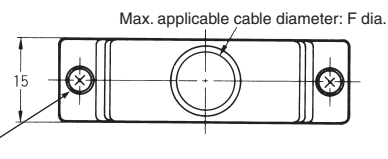

15, 25 and 37-contact Hood  
with Straight Connecting Cable  
XM2S-□□1□

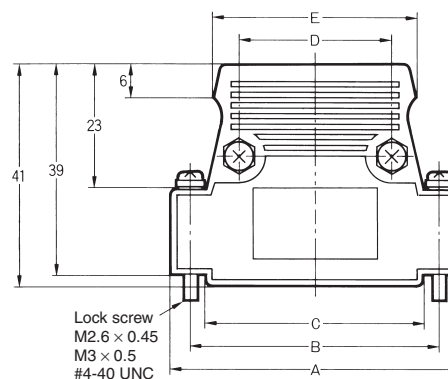
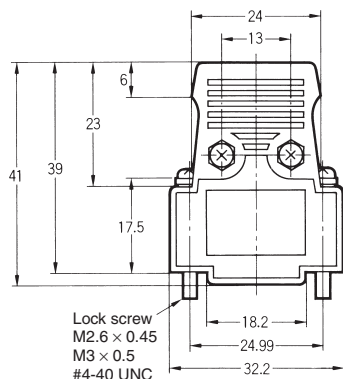
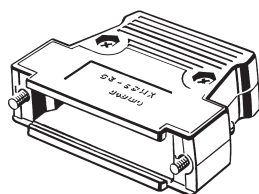

Dot Shape		
No dot	1 dot	2 dots

No. of contacts	A	B	C	D	E	F
15	40.5	33.32	26.5	19	30	10
25	54.0	47.04	40	29	38	11
37	70.5	63.50	57	42	50	13

9-contact Hood with  
Right-angle Connecting Cable  
XM2S-092□

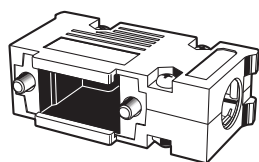

(unit:mm)

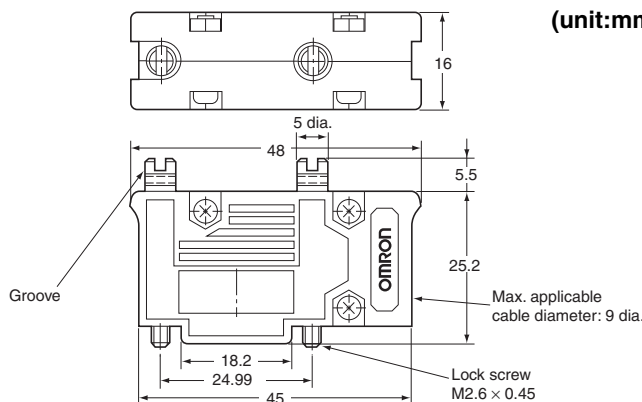

25-contact Hood with  
Right-angle Connecting Cable  
XM2S-252□

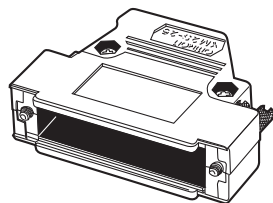

**Note:** The maximum applicable cable diameter for the 25-contact right-angle hood is 9 dia if the cable clamp supplied is mounted facing the rear.  
Do not use a cable bushing in this case.

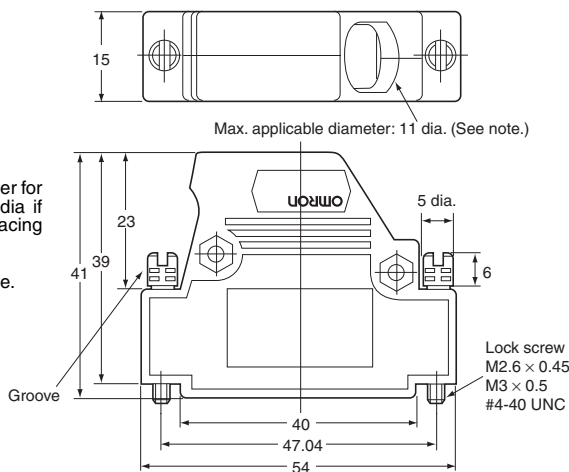

Groove Shape		
No Groove	1 Groove	2 Grooves



**9-contact Hood with Straight Connecting Cable and ESD Protection XM2S-0911-E**

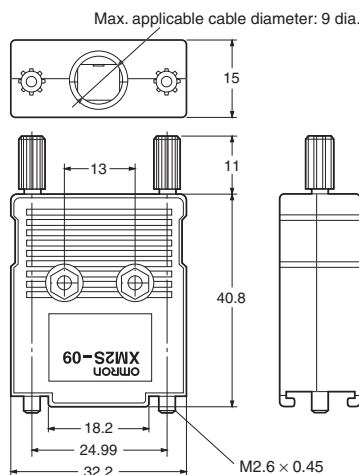
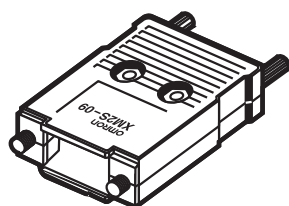

(unit:mm)

**Note:** Jackscrews (thumbscrews) for the straight, non-ESD version of the XM2S hood are sold separately. See “Accessories” section of this datasheet.

**Ordering Information**  
**Straight hoods**

		Lock screw	M2.6 x 0.45 metric screws (No dot)	M3 x 0.5 metric screws (1 dot)	#4-40 UNC inch screws (2 dots)
Applicable Anchors	Anchor 1		XM2Z-0001	XM2Z-0002	XM2Z-0003
	Anchor 2		XM2Z-0011	XM2Z-0012	XM2Z-0013
	Anchor 3		XM2Z-0021	XM2Z-0022	XM2Z-0023
No. of contacts					
9			XM2S-0911	XM2S-0912	XM2S-0913
15			XM2S-1511	XM2S-1512	XM2S-1513
25			XM2S-2511	XM2S-2512	XM2S-2513
37			XM2S-3711	XM2S-3712	XM2S-3713

\*Jackscrews(thumbscrews) for the straight hoods without ESD protection are sold separately. See XM2Z-007□ (Anchor 5) in the Accessories section of this datasheet.

**Right-angle hoods**

		Lock screw	M2.6 x 0.45 metric screws (No groove)	M3 x 0.5 metric screws (1 groove)	#4-40 UNC inch screws (2 groove)
Applicable Anchors	Anchor 1 (See Note 3)		XM2Z-0001	XM2Z-0002	XM2Z-0003
	Anchor 2		XM2Z-0011	XM2Z-0012	XM2Z-0013
	Anchor 3		XM2Z-0021	XM2Z-0022	XM2Z-0023
No. of contacts					
9			XM2S-0921	XM2S-0922	XM2S-0923
25			XM2S-2521	XM2S-2522	XM2S-2523

\*Jackscrews (thumbscrews) for the right-angle hoods are standard, supplied with the hoods.

**Straight hood with ESD Protection**

		Lock screw	M2.6 x 0.45 metric screws (No groove)
Applicable Anchors	Anchor 1		XM2Z-0001
	Anchor 2		XM2Z-0011
	Anchor 3		XM2Z-0021
No. of contacts			
9			XM2S-0911-E

\*Overmolded Jackscrews (thumbscrews) for the straight hoods with ESD protection are standard, supplied with the hoods.

- Note:**
1. The cable bushing, cable clamp, shielded tape and assorted screws are supplied with all hoods
  2. Lock screws are attached to the Hood. Select D-sub Connectors with Anchors or Grounding Fixtures that fit the lock screw of the hood.
  3. Anchor 1 cannot be used with the 9 Contact Right-angle Hoods.

# Accessories for XM3 (Sold Separately)

## ■ XM2T Dust Covers for Sockets

With Retaining Ring  
XM2T-□□01

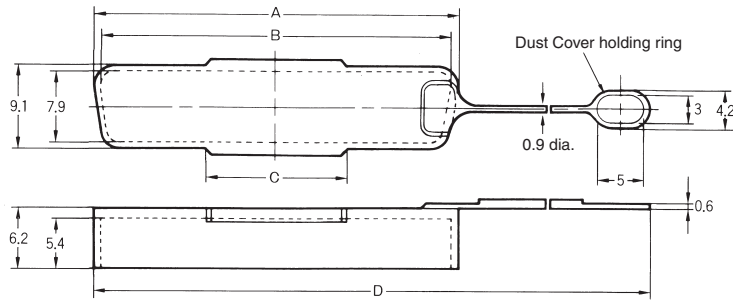
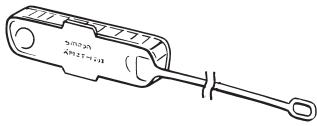

No. of contacts	A	B	C	D	Model
9	17.7	16.3	8	68	XM2T-0901
15	26.1	24.7	10	77	XM2T-1501
25	39.8	38.4	15	120	XM2T-2501
37	56.2	54.8	18	135	XM2T-3701

Without Retaining Ring  
XM2T-□□01-0

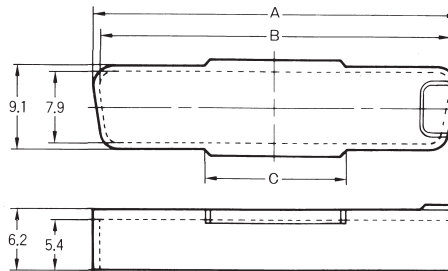
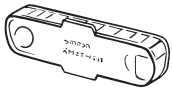

No. of contacts	A	B	C	Model
9	17.7	16.3	8	XM2T-0901-0
15	26.1	24.7	10	XM2T-1501-0
25	39.8	38.4	15	XM2T-2501-0
37	56.2	54.8	18	XM2T-3701-0

XM2T Rating and Material	
Operating Temperature	-25°C to 85°C
Material	Polyamide resin

## ■ XM2Z Anchors

Anchor 1 (Rectangular)  
XM2Z-000□

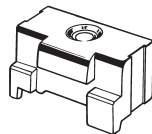

Materials and Finish  
Zinc die-cast/nickel plated

Thread Type	Model
M2.6 x 0.45 metric screw	XM2Z-0001
M3 x 0.5 metric screws	XM2Z-0002
#4-40 UNC inch screws	XM2Z-0003

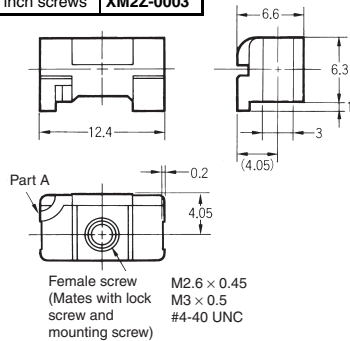

Note: When using a Dust Cover, secure the holding ring at part A.

Anchor 2 (Hexagonal)  
XM2Z-001□



Materials and Finish  
Iron/nickel plated

Thread Type	Model
M2.6 x 0.45 metric screw	XM2Z-0011
M3 x 0.5 metric screws	XM2Z-0012
#4-40 UNC inch screws	XM2Z-0013

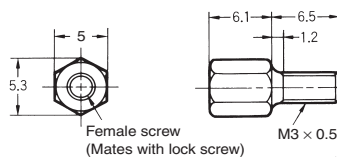

Anchor 3 (Hexagonal)  
XM2Z-002□



Materials and Finish  
Iron/nickel plated

Thread Type	Model
M2.6 x 0.45 metric screw	XM2Z-0021
M3 x 0.5 metric screws	XM2Z-0022
#4-40 UNC inch screws	XM2Z-0023

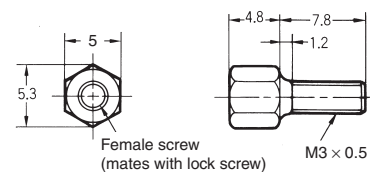

Note: Anchor 3 is used for panel mounting connectors. Applicable cable panel thickness is 0.6 to 1.3 mm.

Note: 2 anchors are necessary per connector. Anchors are not packaged in pairs.

**Anchor 5**  
**XM2Z-007**

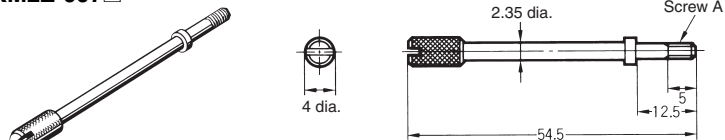

Materials and Finish  
Brass/nickel plated

**Note:** Anchor 5 is for use only with the Straight Connecting XM2S hoods, to provide a Thumbscrew feature. 2 anchors are necessary per connector. Anchors are not packaged in pairs.

Thread Type (A)	Number of Grooves	Groove Shape	Model
M2.6 x 0.45 metric screw	None		XM2Z-0071
M3 x 0.5 metric screws	1		XM2Z-0072
#4-40 UNC inch screws	2		XM2Z-0073

**XM2Z Grounding Fixtures for XM3B**

**Tap Hole Grounding Fixtures**  
**XM2Z-006**

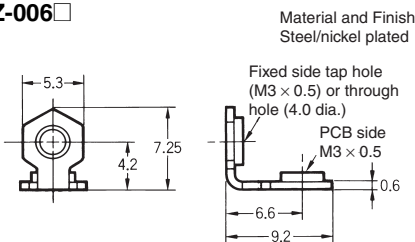

**Lock Pin Grounding Fixtures**  
**XM2Z-006**

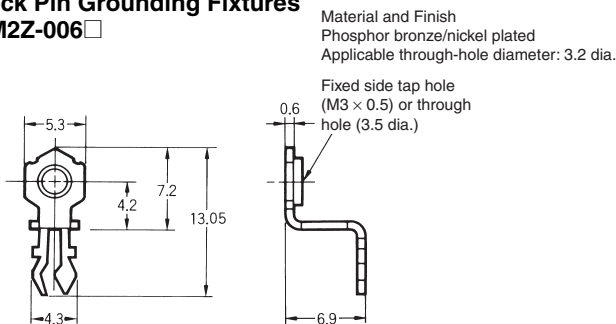

Thread Type	Tap Hole Grounding Fixtures	Lock Pin Grounding Fixtures
Fixed-side tap holes	XM2Z-0061	XM2Z-0062
Fixed-side through holes	XM2Z-0063	XM2Z-0064

**Note:** 2 Grounding Fixtures are necessary per connector. Grounding Fixtures are not packaged in pairs.

**Assembly Information**

**Anchors and Grounding Fixtures**

<p>Anchor 2 and 3</p> <p><b>Note:</b> Use Grounding Fixtures XM2Z-0061 or XM2Z-0062.</p>	<p>Anchor 1</p> <p><b>Note:</b> 1. Use Grounding Fixtures XM2Z-0063 or XM2Z-0064. 2. Use a 6-mm screw that mates with the male screw on Anchor 1.</p>	<p>Without Anchor</p> <p><b>Note:</b> Always use a screw without an Anchor. A grounding Fixture (fixed-side tap) can be used in place of the hexagonal nut.</p>
--	---	---

**Combination of Hexagonal Anchors for each connector (in post installation)**

Type	Model	Without Panel Insertion	With Panel Insertion	Commercially available nut
DIP L type socket	XM3B-□□22	XM2Z-001□	XM2Z-002□	Necessary
	XM3B-□□22-501□			Not Necessary
	XM3B-□□22-502			
DIP L type plug	XM3C-□□22	XM2Z-001□	XM2Z-002□	Necessary
	XM3C-□□22-501			Not Necessary
	XM3C-□□22-502			
DIP straight socket	XM3F-□□20	XM2Z-001□	XM2Z-002□	Necessary

# Combination Examples

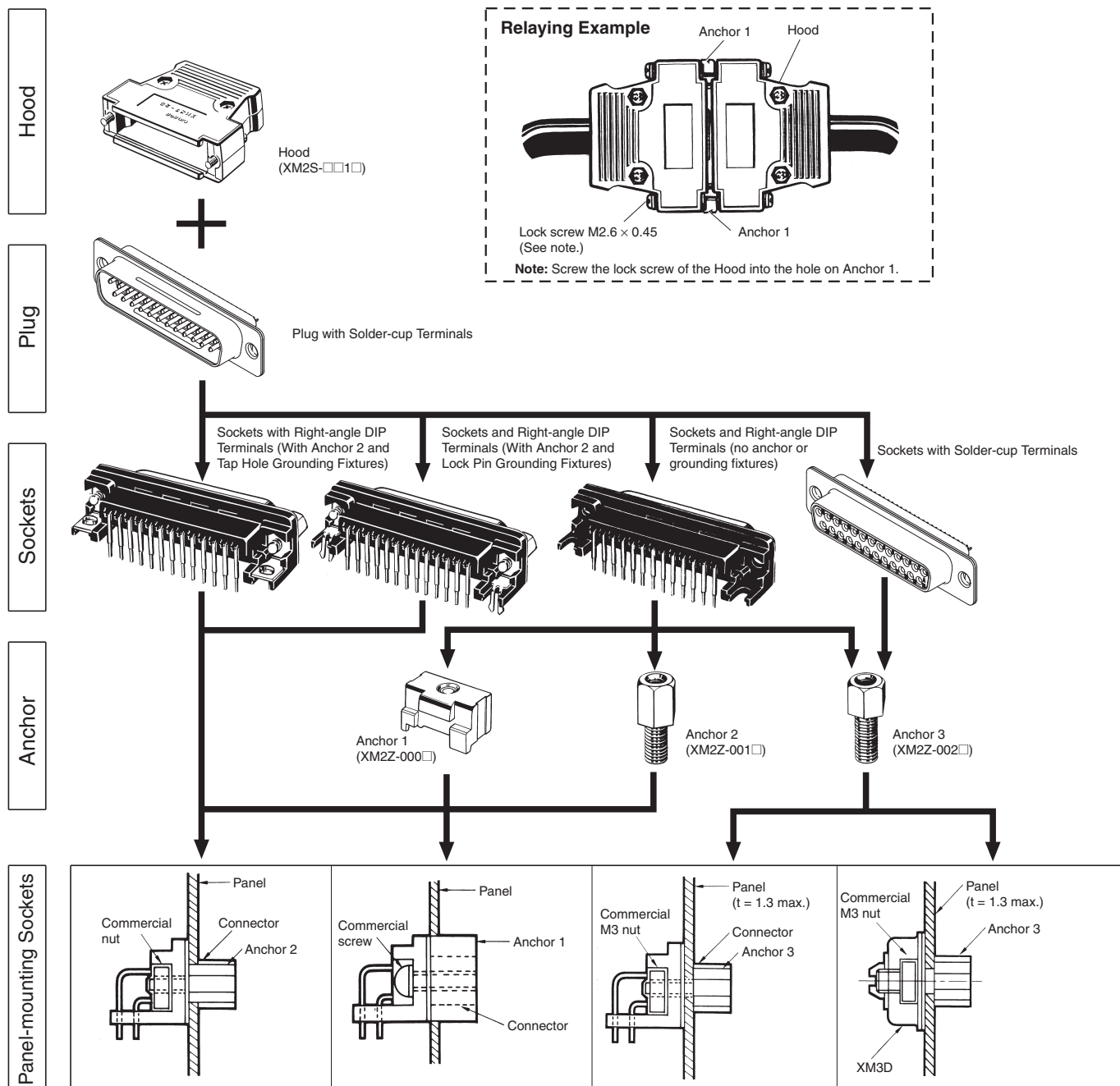

Panel mounting procedure	Not secured to the panel		Secured to the panel																																					
	Anchor 2	Anchor 1	Anchor 3 or M3 screws																																					
Applicable anchors	Anchor 2	Anchor 1	Anchor 3 or M3 screws																																					
Panel dimensions																																								
	Two, R3.2      Four, R2.5		Four, R1		Four, R3.4																																			
	<table border="1"> <thead> <tr> <th>No. of contacts</th> <th>A (mm)</th> </tr> </thead> <tbody> <tr> <td>9</td> <td>31.0</td> </tr> <tr> <td>15</td> <td>39.4</td> </tr> <tr> <td>25</td> <td>53.3</td> </tr> <tr> <td>37</td> <td>69.6</td> </tr> </tbody> </table>		No. of contacts	A (mm)	9	31.0	15	39.4	25	53.3	37	69.6	<table border="1"> <thead> <tr> <th>No. of contacts</th> <th>A (mm)</th> </tr> </thead> <tbody> <tr> <td>9</td> <td>34.1</td> </tr> <tr> <td>15</td> <td>42.4</td> </tr> <tr> <td>25</td> <td>56.1</td> </tr> <tr> <td>37</td> <td>72.6</td> </tr> </tbody> </table>		No. of contacts	A (mm)	9	34.1	15	42.4	25	56.1	37	72.6	<table border="1"> <thead> <tr> <th>No. of contacts</th> <th>A (mm)</th> <th>B (mm)</th> </tr> </thead> <tbody> <tr> <td>9</td> <td>24.99</td> <td>20.5</td> </tr> <tr> <td>15</td> <td>33.32</td> <td>28.8</td> </tr> <tr> <td>25</td> <td>47.04</td> <td>42.5</td> </tr> <tr> <td>37</td> <td>63.50</td> <td>59.1</td> </tr> </tbody> </table>	No. of contacts	A (mm)	B (mm)	9	24.99	20.5	15	33.32	28.8	25	47.04	42.5	37	63.50	59.1
	No. of contacts	A (mm)																																						
9	31.0																																							
15	39.4																																							
25	53.3																																							
37	69.6																																							
No. of contacts	A (mm)																																							
9	34.1																																							
15	42.4																																							
25	56.1																																							
37	72.6																																							
No. of contacts	A (mm)	B (mm)																																						
9	24.99	20.5																																						
15	33.32	28.8																																						
25	47.04	42.5																																						
37	63.50	59.1																																						

**Note:** 1. 2 Anchors are required per connector. Anchors are not packaged in pairs  
 2. Applicable panel thickness is 1.3 mm max.

# Precautions

## Correct Use

### Grounding

To ground, create copper foil around the connector attachment hole on the board, assemble the connector and grounding fixture, and dip in solder as shown below.

#### Tap Hole Grounding Fixtures

Insert the connector into the PCB, tighten the screws, and then dip-solder the connector terminals to the board.

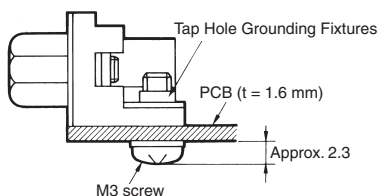

#### Lock Pin Grounding Fixtures

Insert the connector into the PCB and then simultaneously dip-solder the connector terminals and lock pin to the board.

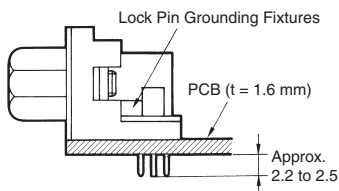

### Attaching the Dust Cover

To attach the cord to the connector, use Anchor 1 and secure it as shown below.

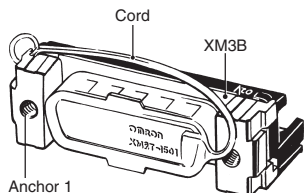

To attach the cord to a panel, drill an M3 hole in the panel and secure the cord to it with an M3 screw. If the cord is not required, cut it off. Use a commercially available M3 screw.

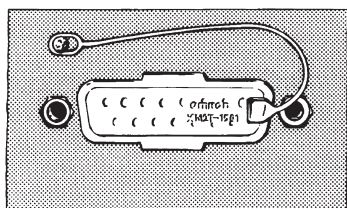

### Tightening Clamp Screws

Use the following torques when tightening cable clamp to hood.

#### Terminal Screw Tightening Torque (N·m)

9 Contacts	15 Contacts	25 Contacts	37 Contacts
0.25	0.44	0.49	

### Shielded Cable Preparation

Refer to the following diagram when soldering shielded cable to the connector when using a hood.

No. of Contacts	L (mm)
9	25
15	35
25	40
37	45

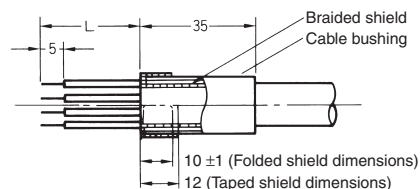

1. Fold the unravelled braided shield back over the cable bushing
2. Wrap tape around the folded shield.

### Shield Effects

When connecting the braided cable shield to a connector hood, use the cable clamp to clamp all the braids at once through the shielded tape.

Mate the lock screw washer and spring washer outside the connector when assembling the hood.

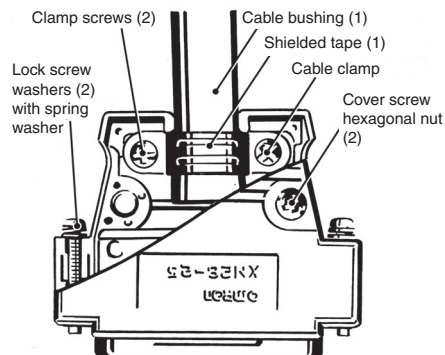

Keep the shell flange of the connector as far away from the metal panel as possible to maximize the shield effect with a connector mounted to a panel.

The ground wire for the connector will fall into the shell (external metal covering) with solder-cup terminals, so connect the ground wire to the panel or to ground on the board.

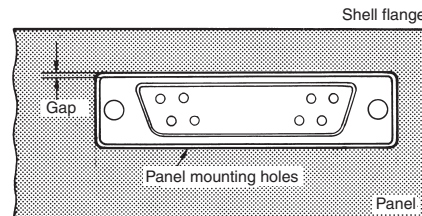

### XM3A/XM3D Connector Insertion and Removal

Grasp the connector or the hood cover when inserting and removing the connector. Never try to remove the connector by pulling the cable.

### Soldering - Automated Soldering Conditions. (Jet Flow) (XM3B, XM3C and XM3F)

1. Soldering temperature: 250 ±5°C
2. Continuous soldering time: Within 5 s

All sales are subject to Omron Electronic Components LLC standard terms and conditions of sale, which can be found at [http://www.components.omron.com/components/web/webfiles.nsf/sales\\_terms.html](http://www.components.omron.com/components/web/webfiles.nsf/sales_terms.html)

**ALL DIMENSIONS SHOWN ARE IN MILLIMETERS.**  
To convert millimeters into inches, multiply by 0.03937. To convert grams into ounces, multiply by 0.03527.

---

**OMRON**<sup>®</sup>

**OMRON ELECTRONIC  
COMPONENTS LLC**

55 E. Commerce Drive, Suite B  
Schaumburg, IL 60173

**847-882-2288**

**OMRON ON-LINE**

Global - <http://www.omron.com>

USA - <http://www.components.omron.com>

Cat. No. G057-E-1a

01/13

Specifications subject to change without notice

Printed in USA

## Данный компонент на территории Российской Федерации

### Вы можете приобрести в компании MosChip.

Для оперативного оформления запроса Вам необходимо перейти по данной ссылке:

<http://moschip.ru/get-element>

Вы можете разместить у нас заказ для любого Вашего проекта, будь то серийное производство или разработка единичного прибора.

В нашем ассортименте представлены ведущие мировые производители активных и пассивных электронных компонентов.

Нашей специализацией является поставка электронной компонентной базы двойного назначения, продукции таких производителей как XILINX, Intel (ex.ALTERA), Vicor, Microchip, Texas Instruments, Analog Devices, Mini-Circuits, Amphenol, Glenair.

Сотрудничество с глобальными дистрибьюторами электронных компонентов, предоставляет возможность заказывать и получать с международных складов практически любой перечень компонентов в оптимальные для Вас сроки.

На всех этапах разработки и производства наши партнеры могут получить квалифицированную поддержку опытных инженеров.

Система менеджмента качества компании отвечает требованиям в соответствии с ГОСТ Р ИСО 9001, ГОСТ РВ 0015-002 и ЭС РД 009

### Офис по работе с юридическими лицами:

105318, г.Москва, ул.Щербаковская д.3, офис 1107, 1118, ДЦ «Щербаковский»

Телефон: +7 495 668-12-70 (многоканальный)

Факс: +7 495 668-12-70 (доб.304)

E-mail: [info@moschip.ru](mailto:info@moschip.ru)

Skype отдела продаж:

moschip.ru

moschip.ru\_4

moschip.ru\_6

moschip.ru\_9