

## LUMAWISE LED Holders

### Type Z50 LED holder for CREE CXA Arrays

The TE Solderless LED Holder, Type Z50, is a circular LED holder that provides a quick and easy solderless connection to the CREE CXA arrays. TE's Type Z50 holder allows the direct attachment of CREE CXA LEDs to a heat sink using standard screws, which enables designs to be easier to use, and faster to market. The Type Z50 reduces assembly costs and provides a quality solderless power connection, secure mechanical attachment, proper thermal hold down forces, and a landing zone with attachment features for additional secondary optics.

#### KEY FEATURES

- Snap-in LED retention feature simplifies installation by securing the LED to the holder before mounting
- Poke-in wire connection eliminates time consuming soldering to the LED
- Enables constant thermal down force to minimize influence by thermal plastic deformation at high temperature
- Makes easy and clean thermal paste application possible with built-in excess paste overflow feature
- Provides a specified and stable landing area for additional secondary optics
- Optional alternate mechanical optic attachment accessory
- Minimalistic aesthetic design with clear polarity indication to aid assembly
- Mechanically strong and robust design with negligible light interference
- Available optics from Carclo and LEDIL

#### APPLICATIONS

- Spotlights
- Down Lights
- Stage lights
- Wall washers
- Architectural lighting

#### MECHANICAL

- Operating temperature range -40 to 105°C
- Utilize a screw size of #4 or M3 for attachment
- Poke-in style electrical contacts supporting 18-22 AWG (0.35 - 0.75mm<sup>2</sup>) solid, fused and stranded wire
- Z50 w/ optics attach: 50mm diameter by 6mm high
- Z50 low profile: 44 mm by 3.4 mm high
- Enables compliancy to Zhaga book 3 standard

#### ELECTRICAL

- Current rating: 5A
- Voltage rating: 300 VDC
- UL1977 and CSA recognized component (cUR)
- IEC 60838-2-2 (up to 60VDC max)

#### MATERIALS

- High mechanical strength
- High heat resistance
- Good electrical properties
- UL94V-0 flammability rating

#### PRODUCT OFFERING

| <u>Holder Style</u>                                   | <u>CXA18xx</u>   | <u>CXA25xx</u>   |
|---|------------------|------------------|
| Z50 low profile holder:                               | <b>2213401-1</b> | <b>2213407-1</b> |
| Z50 with optic attachment:                            | <b>2213401-2</b> | <b>2213407-2</b> |
| <u>Optional Z50 Reflector Optics Retaining Clips:</u> |                  |                  |
| Model 1 for LEDIL optics:                             | <b>2213194-1</b> |                  |
| Model 2 for Khatod optics :                           | <b>2213349-1</b> |                  |

#### APPLICATIONS AND SPECIFICATIONS

- Application Specification #: **114-32048**
- Product Specification #: **108-133008**
- Product Qualification Report #: **501-19197**



INTELLIGENT BUILDINGS

PRODUCT DIMENSIONS

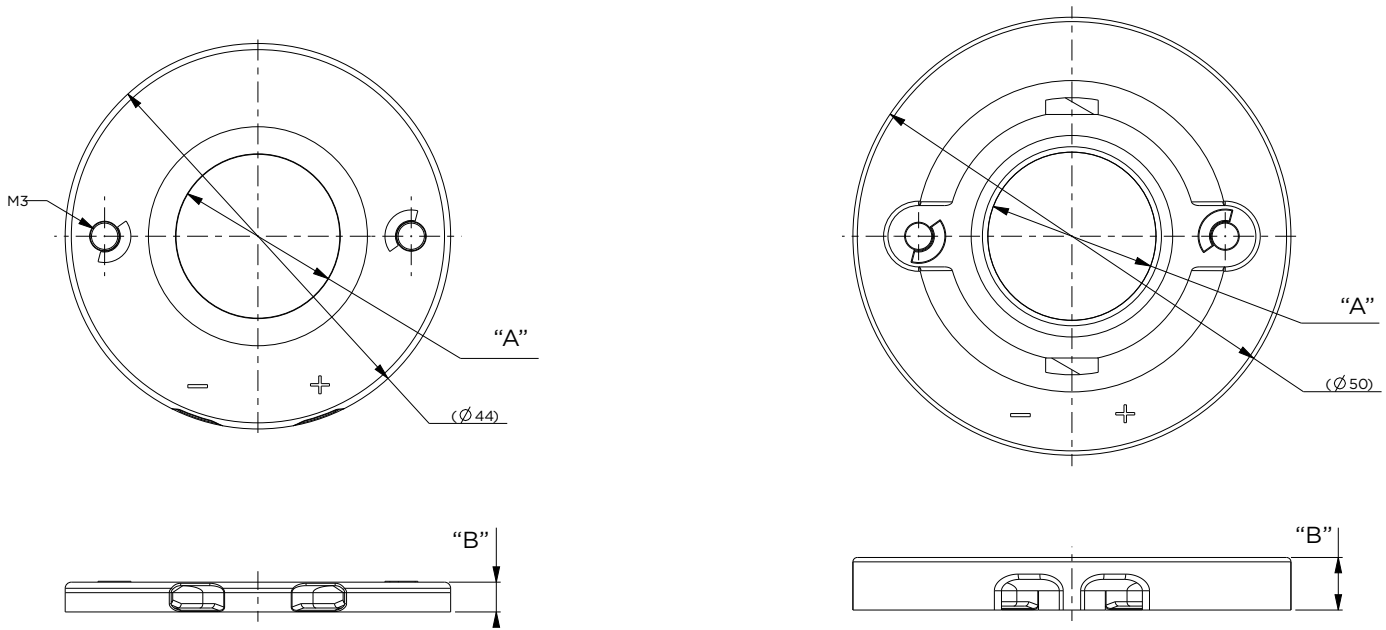

Z50 Low Profile

Z50 with optic attachment features

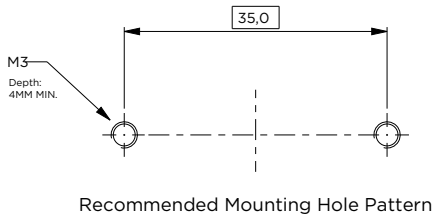

| For COB LED | Profile       | "A"   | "B"    | TE Part No. |
|-------------|---------------|-------|--------|-------------|
| CXA18xx     | Low Profile   | 13 mm | 3.4 mm | 2213401-1   |
|             | Optics Attach | 13 mm | 6 mm   | 2213401-2   |
| CXA25xx     | Low Profile   | 19 mm | 3.4 mm | 2213407-1   |
|             | Optics Attach | 19 mm | 6 mm   | 2213407-2   |

Available Optics

| TE Holder              | Optics Partner | Product                               | Website               | TE Attachment Accessory Required                              |
|------------------------|----------------|---------------------------------------|-----------------------|---|
| 2213401-2<br>2213407-2 |                | NEWTON Series Reflectors              | www.carclo-optics.com | None  |
| 2213401-2<br>2213407-2 |                | ANGELA and ANGELINA Series Reflectors | www.ledil.com         | 2213194-1<br><i>(Reflector Optics Retaining Clip Model 1)</i> |
| 2213401-2<br>2213407-2 |                | LYRA series reflectors                | www.khatod.com        | 2213349-1<br><i>(Reflector Optics Retaining Clip Model 2)</i> |

Dimensions are shown for reference purposes only. Specifications subject to change. Customer drawing should be used for all design activity.



INTELLIGENT BUILDINGS

## Данный компонент на территории Российской Федерации

### Вы можете приобрести в компании MosChip.

Для оперативного оформления запроса Вам необходимо перейти по данной ссылке:

<http://moschip.ru/get-element>

Вы можете разместить у нас заказ для любого Вашего проекта, будь то серийное производство или разработка единичного прибора.

В нашем ассортименте представлены ведущие мировые производители активных и пассивных электронных компонентов.

Нашей специализацией является поставка электронной компонентной базы двойного назначения, продукции таких производителей как XILINX, Intel (ex.ALTERA), Vicor, Microchip, Texas Instruments, Analog Devices, Mini-Circuits, Amphenol, Glenair.

Сотрудничество с глобальными дистрибьюторами электронных компонентов, предоставляет возможность заказывать и получать с международных складов практически любой перечень компонентов в оптимальные для Вас сроки.

На всех этапах разработки и производства наши партнеры могут получить квалифицированную поддержку опытных инженеров.

Система менеджмента качества компании отвечает требованиям в соответствии с ГОСТ Р ИСО 9001, ГОСТ РВ 0015-002 и ЭС РД 009

### Офис по работе с юридическими лицами:

105318, г.Москва, ул.Щербаковская д.3, офис 1107, 1118, ДЦ «Щербаковский»

Телефон: +7 495 668-12-70 (многоканальный)

Факс: +7 495 668-12-70 (доб.304)

E-mail: [info@moschip.ru](mailto:info@moschip.ru)

Skype отдела продаж:

moschip.ru

moschip.ru\_4

moschip.ru\_6

moschip.ru\_9