

D-SUB bus connector - SUBCON-PLUS-F2 - 2799490

Please be informed that the data shown in this PDF Document is generated from our Online Catalog. Please find the complete data in the user's documentation. Our General Terms of Use for Downloads are valid (<http://download.phoenixcontact.com>)



D-SUB connector, 9-pos. female connector, two cable entries < 35°, bus system: CAN, SUCONET K1, K2 (MOELLER), S-BUS (Saia), J-BUS (Merlin Gerin), pin assignment: 2, 3, 4, 5, 7, 9 to two screw connection terminal blocks

The illustration shows version SUBCON-PLUS M 2

Why buy this product

- Separate terminal blocks for each cable
- Easy assembly thanks to knurled screws
- For universal use
- Assembly under field conditions
- High level of EMC
- Flexibility in terms of cable entry selection
- High transmission speed



RS-485



Key commercial data

Packing unit	1
Minimum order quantity	1
Catalog page	Page 574 (IF-2011)
GTIN	 4 017918 156305
Custom tariff number	85366990
Country of origin	GERMANY

Technical data

General data

Nominal voltage U_N	50 V
Nominal current I_N	100 mA
Bus system	CAN, SUCONET K1, K2 (Moeller), S-BUS (Saia), J-BUS (Merlin Gerin)
Insertion/withdrawal cycles	> 200
Max. cable diameter	10 mm
Min. cable diameter	6 mm
SUBCON fixing screws	4-40 UNC

D-SUB bus connector - SUBCON-PLUS-F2 - 2799490

Technical data

General data

Tightening torque	0.4 Nm
Ambient temperature (operation)	-20 °C ... 75 °C
Altitude	5000 m (For restrictions see manufacturer's declaration)
Housing material	ABS, metal-plated
Pin assignment	2,3,4,5,7,9 on two terminal blocks
Width	16 mm
Height	44 mm
Length	60 mm

Connection data

Connection	D-SUB connection
Number of positions	9
Connection method	D-SUB socket
Tightening torque	0.4 Nm
Connection	PCB connection
Connection method	Screw connection
Conductor cross section stranded min.	0.14 mm ²
Conductor cross section stranded max.	1 mm ²
Conductor cross section solid min.	0.14 mm ²
Conductor cross section solid max.	1.5 mm ²
Min. AWG conductor cross section, stranded	26
Max. AWG conductor cross section, stranded	18
Conductor cross section AWG/kcmil min.	26
Conductor cross section AWG/kcmil max	16
Stripping length	5 mm
Tightening torque	0.4 Nm

Classifications

ETIM

ETIM 2.0	EC001132
ETIM 3.0	EC001132
ETIM 4.0	EC001132
ETIM 5.0	EC001132

UNSPSC

UNSPSC 11	39121402
UNSPSC 12.01	39121402
UNSPSC 13.2	39121402
UNSPSC 6.01	30211802
UNSPSC 7.0901	39121402

D-SUB bus connector - SUBCON-PLUS-F2 - 2799490

Classifications

eCl@ss

eCl@ss 4.0	27140816
eCl@ss 4.1	27140816
eCl@ss 5.0	27143424
eCl@ss 5.1	27143424
eCl@ss 6.0	27143424
eCl@ss 7.0	27440209

Approvals

Approvals

Approvals

UL Recognized / cUL Recognized / GOST / cULus Recognized

Ex Approvals

Approvals submitted

Approval details

UL Recognized

cUL Recognized

GOST

cULus Recognized

Accessories

Accessories

Assembly

D-SUB bus connector - SUBCON-PLUS-F2 - 2799490

Accessories

Screw - SUBCON-SHORT-SCREW - 2799694



Optional mounting screw, without knurl for narrow installation conditions, slotted head, length: 40 mm, UNC 4-40 thread

Tools

Screwdriver - SZF 0-0,4X2,5 - 1204504



Actuation tool, for ST terminal blocks, also suitable for use as a bladed screwdriver, size: 0.4 x 2.5 x 75 mm, 2-component grip, with non-slip grip

D-SUB gender changer - VS-09-GC-ST/ST - 1652651



D-SUB contact insert, shell size 1, with nine signal contacts, contact type pin, gender changer, fixing with 4-40 UNC thread

Drawings

Dimensioned drawing

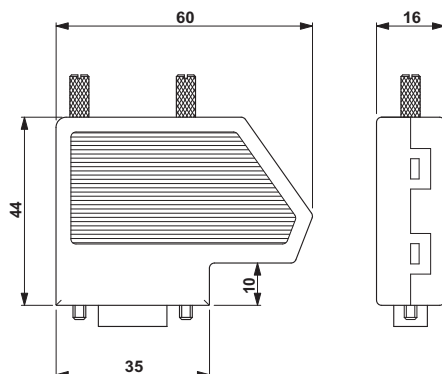

Данный компонент на территории Российской Федерации

Вы можете приобрести в компании MosChip.

Для оперативного оформления запроса Вам необходимо перейти по данной ссылке:

<http://moschip.ru/get-element>

Вы можете разместить у нас заказ для любого Вашего проекта, будь то серийное производство или разработка единичного прибора.

В нашем ассортименте представлены ведущие мировые производители активных и пассивных электронных компонентов.

Нашей специализацией является поставка электронной компонентной базы двойного назначения, продукции таких производителей как XILINX, Intel (ex.ALTERA), Vicor, Microchip, Texas Instruments, Analog Devices, Mini-Circuits, Amphenol, Glenair.

Сотрудничество с глобальными дистрибьюторами электронных компонентов, предоставляет возможность заказывать и получать с международных складов практически любой перечень компонентов в оптимальные для Вас сроки.

На всех этапах разработки и производства наши партнеры могут получить квалифицированную поддержку опытных инженеров.

Система менеджмента качества компании отвечает требованиям в соответствии с ГОСТ Р ИСО 9001, ГОСТ РВ 0015-002 и ЭС РД 009

Офис по работе с юридическими лицами:

105318, г.Москва, ул.Щербаковская д.3, офис 1107, 1118, ДЦ «Щербаковский»

Телефон: +7 495 668-12-70 (многоканальный)

Факс: +7 495 668-12-70 (доб.304)

E-mail: info@moschip.ru

Skype отдела продаж:

moschip.ru

moschip.ru_4

moschip.ru_6

moschip.ru_9