

## SHT1x click™

### 1. Introduction

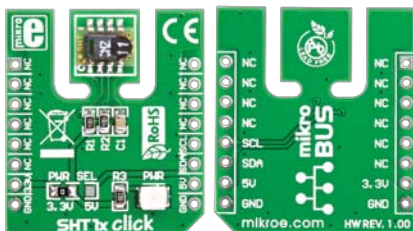

Front and back side appearance of the SHT1x click Board

SHT1x Click is an accessory board in **mikroBus™** form factor. It includes a digital humidity and temperature sensor **SHT11**. A unique capacitive sensor element is used to measure relative humidity while the temperature is measured by a band-gap sensor. Serial I<sup>2</sup>C interface and factory calibration, allow easy and fast system integration. Board is set to use 3.3V power supply by default. Solder **PWR SEL** SMD jumper to 5V position if used with 5V systems.

### 2. Soldering the headers

Before using your click board, make sure to solder the provided 1x8 male headers to both sides of the board. Two 1x8 male headers are included with the board in the package.

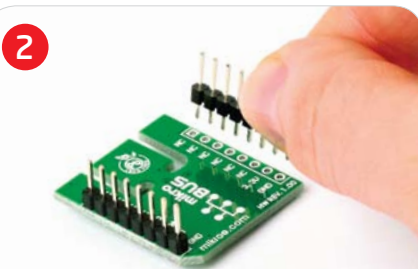

Turn the board upside down, so that bottom side is facing you upwards. Place shorter parts of the header pins in the both soldering pad locations.

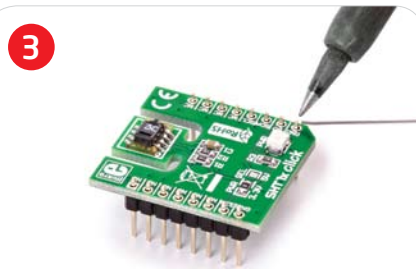

Turn the board upward again. Make sure to align the headers so that they are perpendicular to the board, then solder the pins carefully.

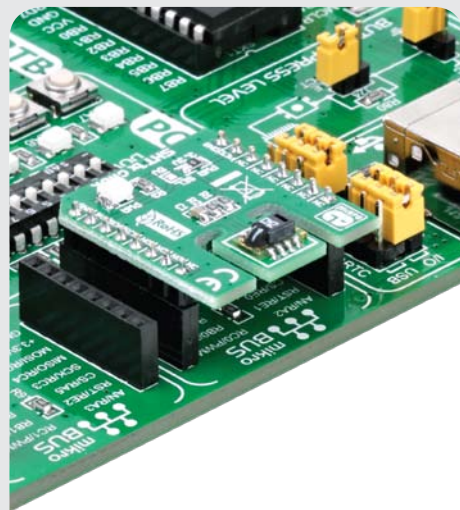

### 4. Getting The Data

Communication with the SHT11 sensor is done using I<sup>2</sup>C interface. Temperature can be represented in 12-bit or 14-bit format in operating range from -40 to +100°C with accuracy of  $\pm 0.5^\circ\text{C}$  at room temperature. Humidity can be represented in 8-bit or 12-bit resolution with  $\pm 3\%$  accuracy.

### 3. Plugging the board in

Once you have soldered the headers your board is ready to be placed into desired mikroBUS™ socket. Make sure to align the cut in the lower-right part of the board with the markings on the silkscreen at the mikroBUS™ socket. If all the pins are aligned correctly, push the board all the way into the socket.

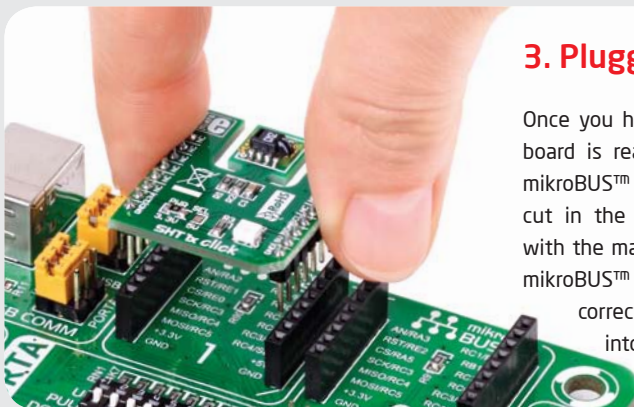

click™  
BOARD  
[www.mikroe.com](http://www.mikroe.com)

SHT11 click Manual  
ver. 1.00



## 5. SHT1x click Board Schematics

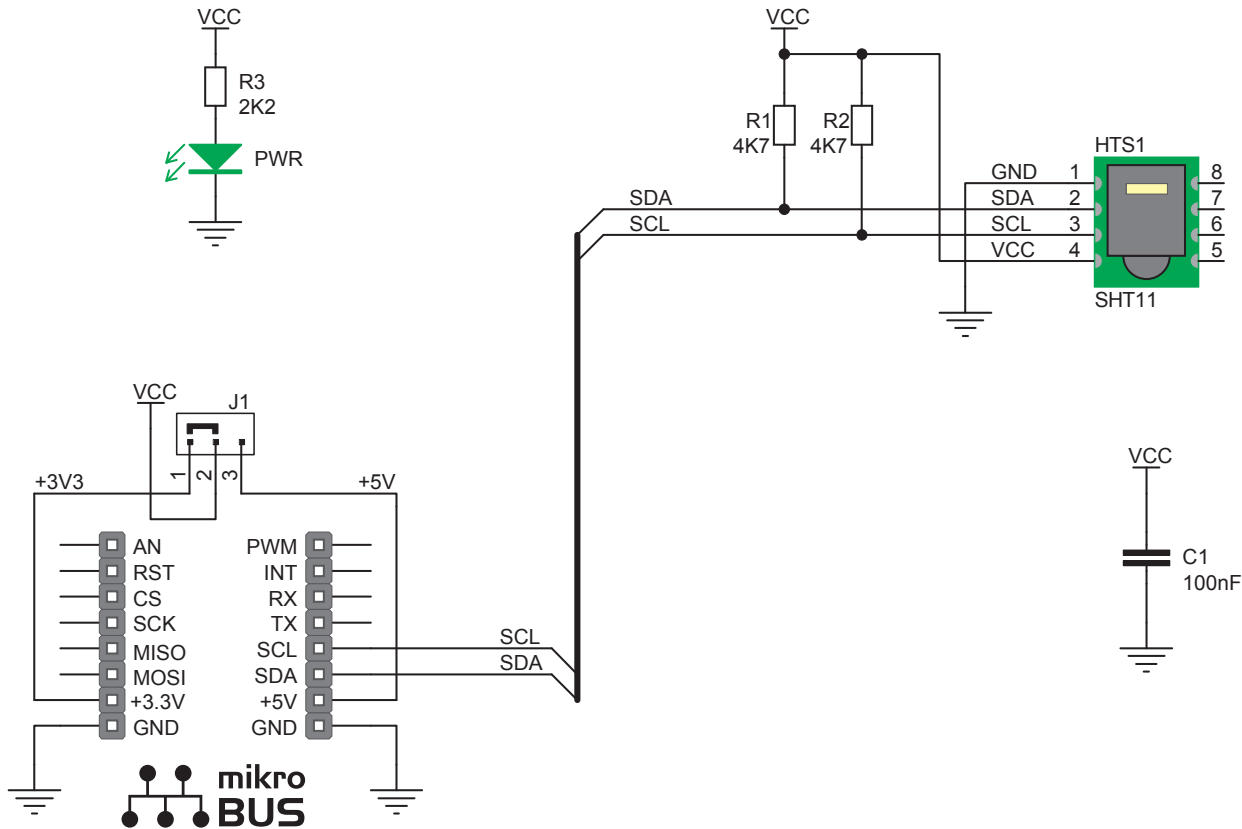

## 6. Power supply selection



On-board **PWR SEL** zero-ohm resistor (SMD jumper) is used to determine whether 5V or 3.3V power supply is used. This resistor is provided in 3.3V position by default. In order to use SHT1x click with 5V development system, it is necessary to resolder this jumper to 5V position.

## 7. Code Examples

Once you have done all the necessary preparations, it's time to get your click board up and running. We have provided the examples for mikroC, mikroBasic and mikroPascal compilers on our **Libstock** website. Just download them and you are ready to start.



## 8. Support

MikroElektronika offers **Free Tech Support** ([www.mikroe.com/esupport](http://www.mikroe.com/esupport)) until the end of product lifetime, so if something goes wrong, we are ready and willing to help!

## Данный компонент на территории Российской Федерации

### Вы можете приобрести в компании MosChip.

Для оперативного оформления запроса Вам необходимо перейти по данной ссылке:

<http://moschip.ru/get-element>

Вы можете разместить у нас заказ для любого Вашего проекта, будь то серийное производство или разработка единичного прибора.

В нашем ассортименте представлены ведущие мировые производители активных и пассивных электронных компонентов.

Нашей специализацией является поставка электронной компонентной базы двойного назначения, продукции таких производителей как XILINX, Intel (ex.ALTERA), Vicor, Microchip, Texas Instruments, Analog Devices, Mini-Circuits, Amphenol, Glenair.

Сотрудничество с глобальными дистрибьюторами электронных компонентов, предоставляет возможность заказывать и получать с международных складов практически любой перечень компонентов в оптимальные для Вас сроки.

На всех этапах разработки и производства наши партнеры могут получить квалифицированную поддержку опытных инженеров.

Система менеджмента качества компании отвечает требованиям в соответствии с ГОСТ Р ИСО 9001, ГОСТ РВ 0015-002 и ЭС РД 009

### Офис по работе с юридическими лицами:

105318, г.Москва, ул.Щербаковская д.3, офис 1107, 1118, ДЦ «Щербаковский»

Телефон: +7 495 668-12-70 (многоканальный)

Факс: +7 495 668-12-70 (доб.304)

E-mail: [info@moschip.ru](mailto:info@moschip.ru)

Skype отдела продаж:

moschip.ru

moschip.ru\_4

moschip.ru\_6

moschip.ru\_9