

Low Power, High Sensitivity, I²C Ambient Light Sensor

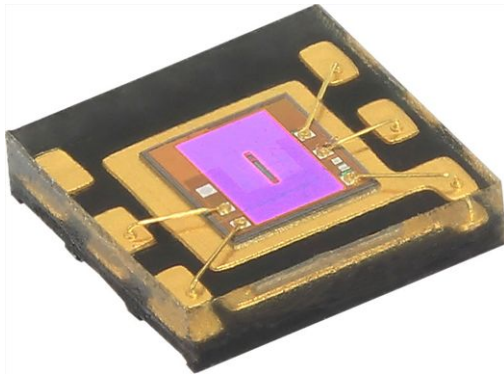

DESCRIPTION

VEML6035 is a 16-bit low power, high sensitivity CMOS ambient light sensor operated via a simple I²C command. The sensor offers an active interruption feature that is triggered outside of the threshold window settings eliminating loading on the host. Active average power consumption is around 300 μ W.

VEML6035 incorporates a photodiode, amplifiers, and analog / digital circuits in a single chip. Vishay's patented Filtron™ technology, a wafer level optical filter, provides the best spectral sensitivity to match human eye responses. The sensor has excellent temperature compensation to maintain output stability under changing temperature and its refresh rate setting does not need an external RC low pass filter. There is a programmable shutdown mode which reduces current consumption to 0.5 μ A. Operating voltage ranges from 1.7 V to 3.6 V.

FEATURES

- Package type: surface-mount
- Dimensions (L x W x H in mm): 2.0 x 2.0 x 0.4
- Integrated modules: ambient light sensor (ALS)
- Supply voltage range V_{DD}: 1.7 V to 3.6 V
- Communication via I²C interface
- I²C bus H-level range: 1.7 V to 3.6 V
- Floor life: 168 h, MSL 3, according to J-STD-020
- Low stand by current consumption: typ. 0.5 μ A
- Material categorization: for definitions of compliance please see www.vishay.com/doc?99912



APPLICATIONS

- Ambient light sensor for mobile devices (e.g. smart phones, touch phones, PDA, GPS) for backlight dimming even under tinted glass
- Ambient light sensor for industrial on- / off-lighting operation
- Optical switch for consumer, computing, and industrial devices and displays

AMBIENT LIGHT FUNCTION

- ALS output tolerance \leq 10 %
- High ALS sensitivity with minimum detectable intensity of 0.0004 lux/bit supports low transmittance lens design
- 100 Hz and 120 Hz flicker noise rejection
- Excellent temperature compensation
- High dynamic detection resolution

INTERRUPT FEATURE (INT) SUPPORT

Programmable interrupt function with upper and lower thresholds. Adjustable persistence to prevent false triggers.

PRODUCT SUMMARY						
PART NUMBER	OPERATING VOLTAGE RANGE (V)	I ² C BUS VOLTAGE RANGE (V)	AMBIENT LIGHT RANGE (lx)	AMBIENT LIGHT RESOLUTION (lx)	OUTPUT CODE	ADC RESOLUTION PROXIMITY / AMBIENT LIGHT
VEML6035	1.7 to 3.6	1.7 to 3.6	6710	0.0004	16 bit, I ² C	- / 0.0004

ORDERING INFORMATION			
ORDERING CODE	PACKAGING	VOLUME ⁽¹⁾	REMARKS
VEML6035	Tape and reel	MOQ: 2500	2.0 mm x 2.0 mm x 0.4 mm

Note

⁽¹⁾ MOQ: minimum order quantity

ABSOLUTE MAXIMUM RATINGS ($T_{amb} = 25\text{ }^{\circ}\text{C}$, unless otherwise specified)					
PARAMETER	TEST CONDITION	SYMBOL	MIN.	MAX.	UNIT
Supply voltage		V_{DD}	0	4	V
Operation temperature range		T_{amb}	-25	+85	$^{\circ}\text{C}$
Storage temperature range		T_{stg}	-25	+85	$^{\circ}\text{C}$
Total power dissipation	$T_{amb} \leq 25\text{ }^{\circ}\text{C}$	P_{tot}	-	50	mW
Junction temperature		T_j	-	85	$^{\circ}\text{C}$

BASIC CHARACTERISTICS ($T_{amb} = 25\text{ }^{\circ}\text{C}$, unless otherwise specified)						
PARAMETER	TEST CONDITION	SYMBOL	MIN.	TYP.	MAX.	UNIT
Supply voltage		V_{DD}	1.7	1.8	3.6	V
Shut down current ⁽²⁾	$V_{DD} = 1.8\text{ V}$	I_{sd}	-	0.5	-	μA
Operation mode current ⁽¹⁾	$V_{DD} = 1.8\text{ V}$, CHANNEL_EN = 0 (ALS only)	I_{DD}	-	170	-	μA
	$V_{DD} = 1.8\text{ V}$, CHANNEL_EN = 1 (ALS and WHITE)	I_{DD}	-	225	-	μA
I ² C clock rate range		f_{SCL}	10	-	400	kHz
I ² C bus input H-level range	$V_{DD} = 1.8\text{ V}$	V_{ih}	1.2	-	V_{DD}	V
I ² C bus input L-level range	$V_{DD} = 1.8\text{ V}$	V_{il}	0	-	0.4	V
Output low voltage SDA	3 mA sink current	V_{ol}	0	-	0.4	V
Digital resolution (LSB count)	With GAIN = 1, DG = 1, SENS = 0		-	0.0004	-	lx/step
Detectable minimum illuminance ⁽³⁾	With GAIN = 1, DG = 1, SENS = 0	$E_{V\ min.}$	-	0.004	-	lx
Detectable maximum illuminance	With GAIN = 0, DG = 0, SENS = 1	$E_{V\ max.}$	-	6710	-	lx
Dark offset ⁽⁴⁾	With GAIN = 1, DG = 1, SENS = 0		-	-	5	step

Notes

- (1) Light source: white LED
- (2) Light conditions: dark
- (3) The part has a typical zero offset of 10 counts at the set max. resolution of 0.0004lx/step, so the first valid measurement will be at an illuminance of 0.004lx (typ.)
- (4) The dark offset can be above or below 0

CIRCUIT BLOCK DIAGRAM

Fig. 1 - Block Diagram

I²C TIMING CHARACTERISTICS ($T_{amb} = 25\text{ }^{\circ}\text{C}$, unless otherwise specified)						
PARAMETER	SYMBOL	STANDARD MODE ⁽¹⁾		FAST MODE ⁽¹⁾		UNIT
		MIN.	MAX.	MIN.	MAX.	
Clock frequency	$f_{(SMBCLK)}$	10	100	10	400	kHz
Bus free time between start and stop condition	$t_{(BUF)}$	4.7	-	1.3	-	μs
Hold time after (repeated) start condition; after this period, the first clock is generated	$t_{(HDSTA)}$	4.0	-	0.6	-	μs
Repeated start condition setup time	$t_{(SUSTA)}$	4.7	-	0.6	-	μs
Stop condition setup time	$t_{(SUSTO)}$	4.0	-	0.6	-	μs
Data hold time	$t_{(HDDAT)}$	0	3450	0	900	ns
Data setup time	$t_{(SUDAT)}$	250	-	100	-	ns
I ² C clock (SCK) low period	$t_{(LOW)}$	4.7	-	1.3	-	μs
I ² C clock (SCK) high period	$t_{(HIGH)}$	4.0	-	0.6	-	μs
Detect clock / data low timeout	$t_{(TIMEOUT)}$	25	35	-	-	ms
Clock / data fall time	$t_{(F)}$	-	300	-	300	ns
Clock / data rise time	$t_{(R)}$	-	1000	-	300	ns

Note

(1) Data based on standard I²C protocol requirement, not tested in production

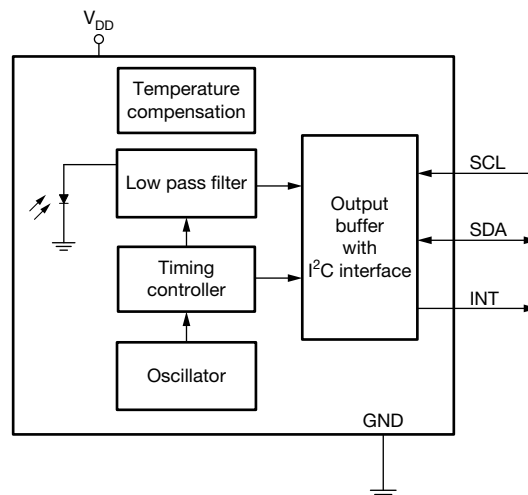
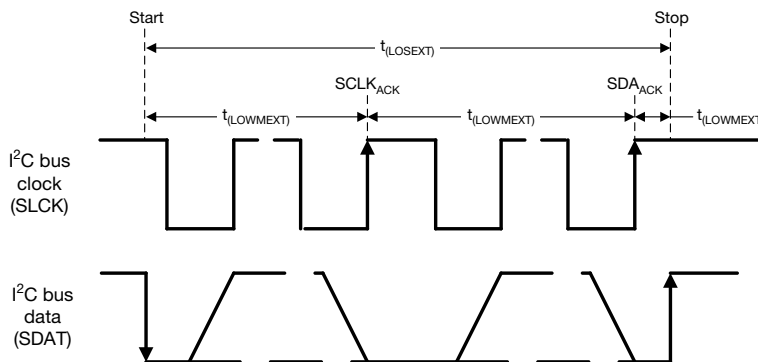
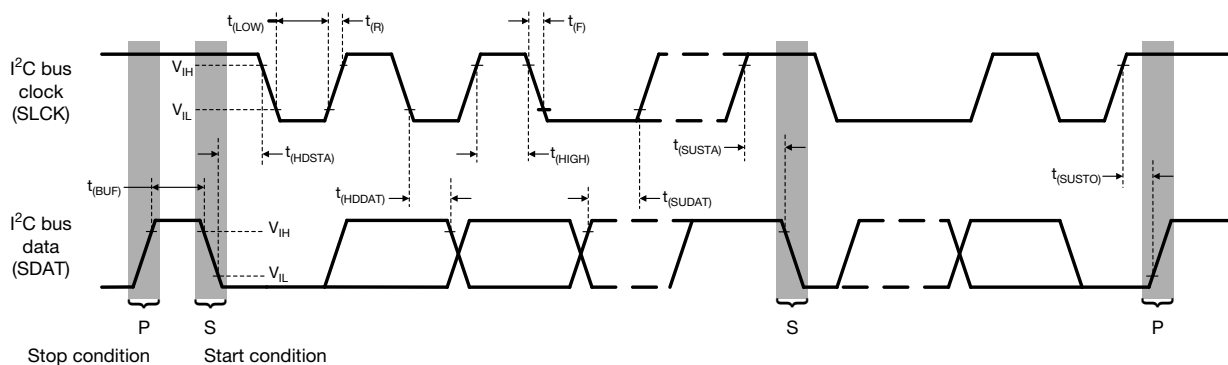

Fig. 2 - I²C Timing Diagram

PARAMETER TIMING INFORMATION

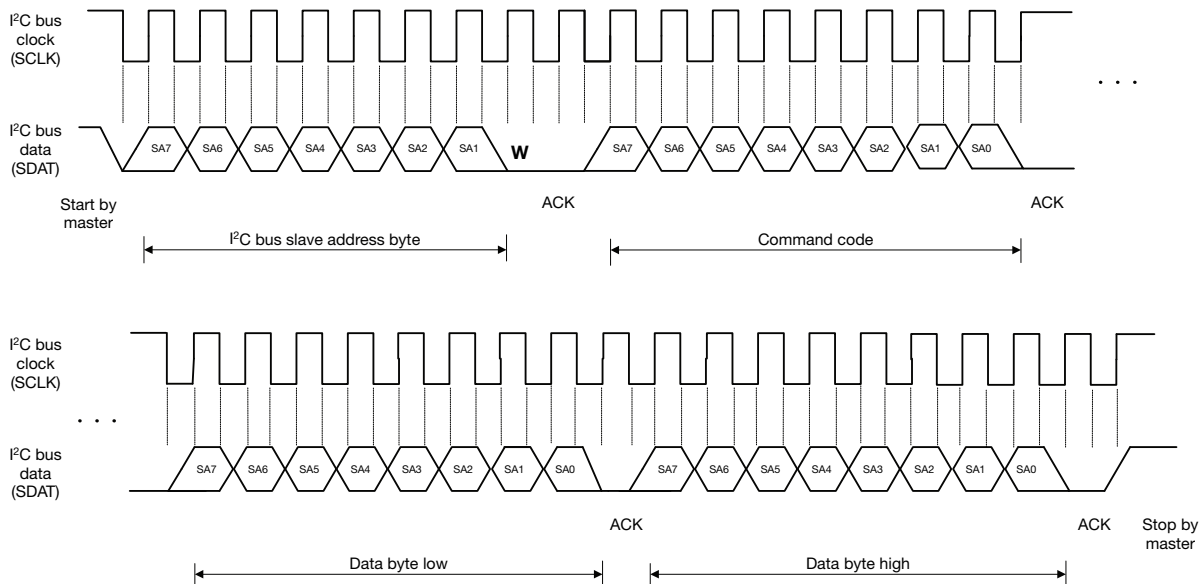

Fig. 3 - I²C Bus Timing for Sending Word Command Format

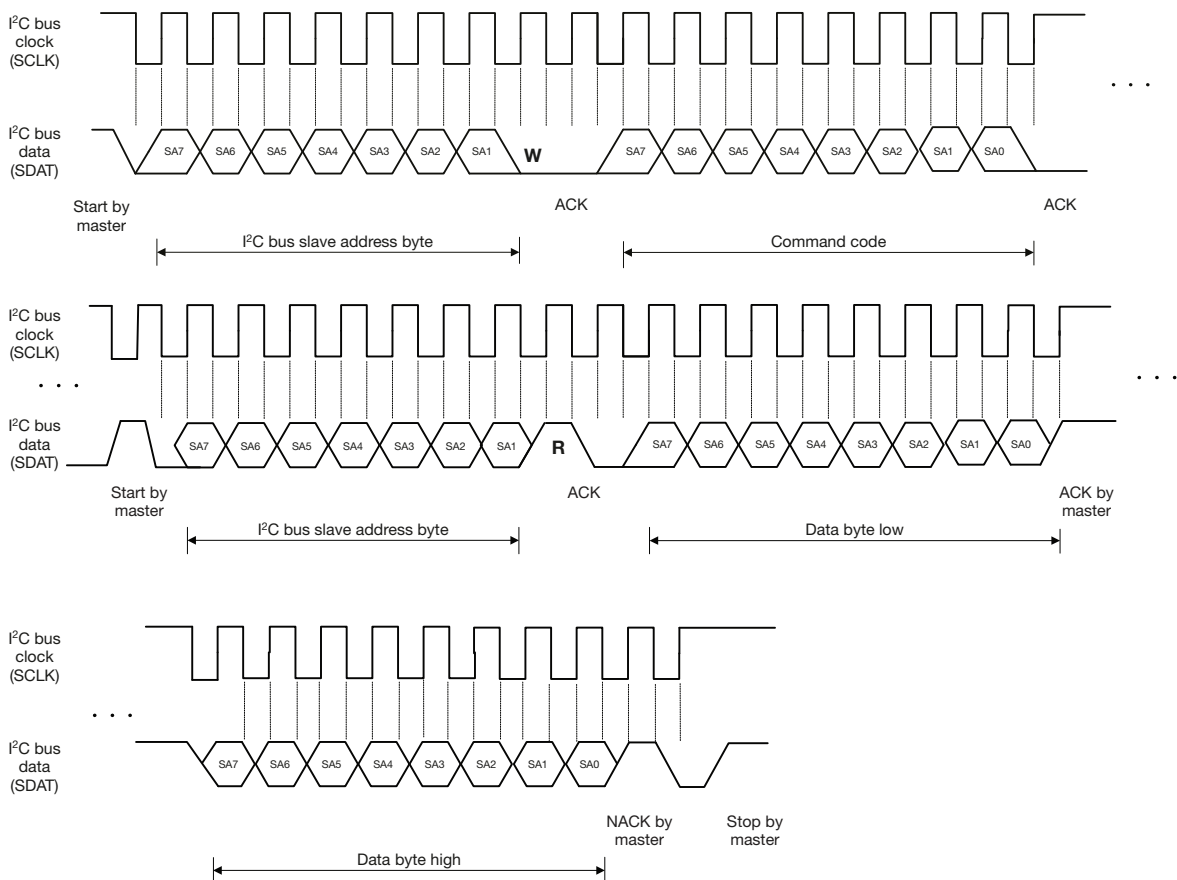

Fig. 4 - I²C Bus Timing for Receive Word Command Format

BASIC CHARACTERISTICS ($T_{amb} = 25\text{ }^{\circ}\text{C}$, unless otherwise specified)

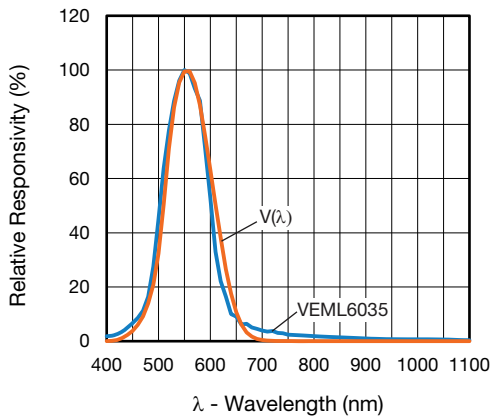

Fig. 5 - Normalized ALS Channel Spectral Response

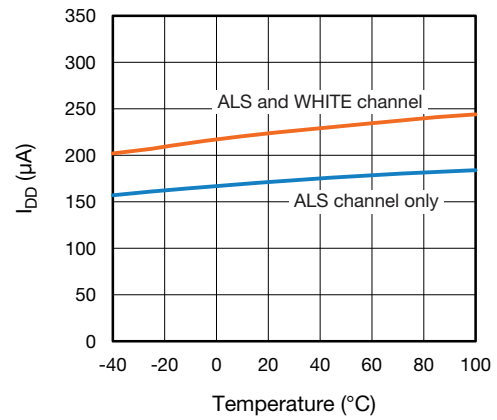

Fig. 8 - I_{DD} vs. Temperature Characteristics

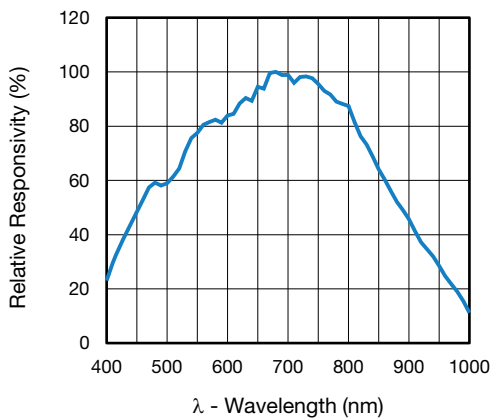

Fig. 6 - Normalized WHITE Channel Spectral Response

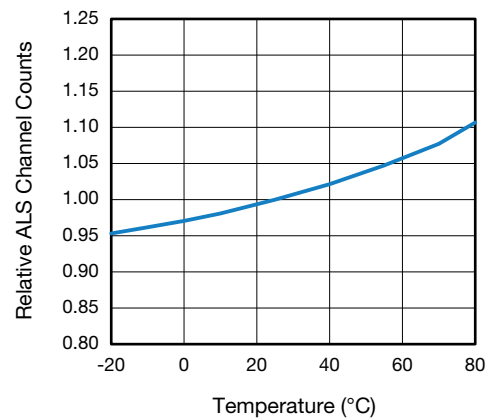

Fig. 9 - Normalized ALS Counts vs. Temperature

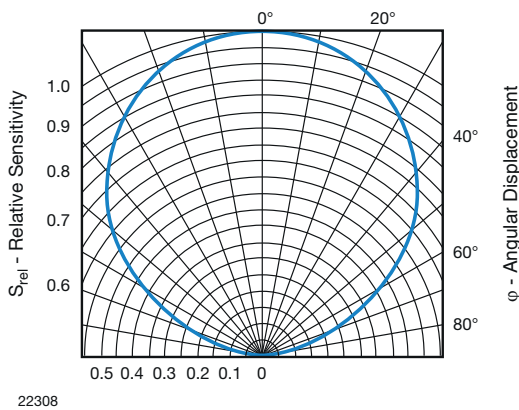

Fig. 7 - View Angle

APPLICATION INFORMATION

VEML6035 is a cost effective solution of ambient light sensor with I²C bus interface. The standard serial digital interface is easy to access “Ambient Light Signal” without complex calculation and programming by external controller. Beside the digital output also a flexible programmable interrupt pin is available.

1. Application Circuit

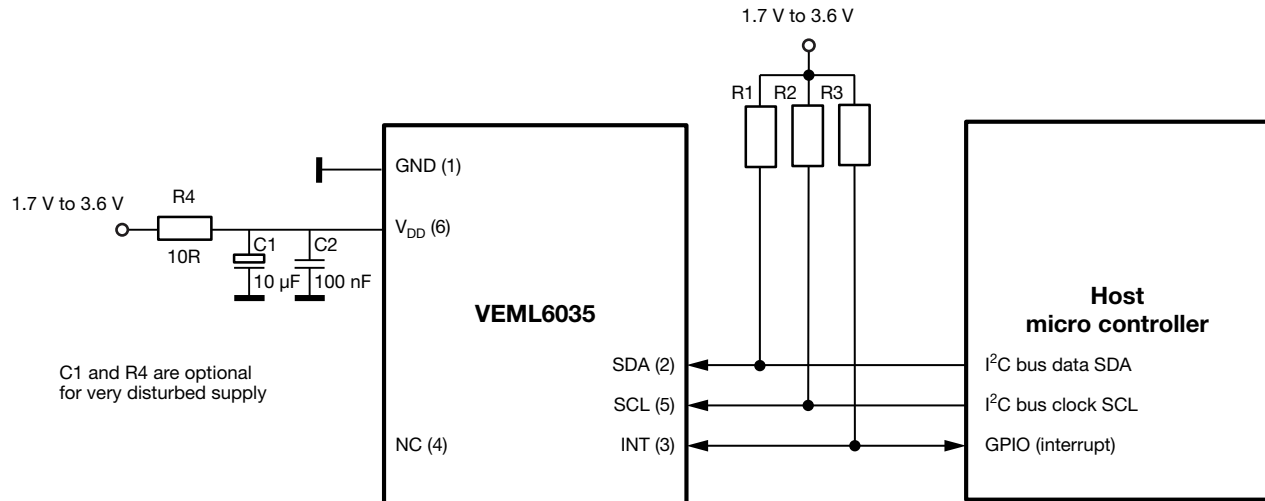

Fig. 10 - Application Circuit
(x) = Pin Number

Note

- The interrupt pin is an open drain output. Proposed values for the pull-up resistors should be > 1 kΩ, e.g. 2.2 kΩ to 4.7 kΩ for the R1 and R2 (at SDA and SCL) and 10 kΩ to 100 kΩ for R3 (at interrupt). Normally just one decoupling capacitor is needed. This should be ≥ 100 nF and placed close to the V_{DD} pin. For detailed description about set-up and use of the interrupt as well as more application related information see application note: “Designing VEML6035 Into an Application” (www.vishay.com/doc?84944)

2. I²C Interface

The VEML6035 contains actual six 16 bit command codes for operation control, parameter setup, and result buffering. All registers are accessible via I²C communication. Fig. 7 shows the basic I²C communication with VEML6035. The built in I²C interface is compatible with I²C modes “standard” and “fast”: 10 kHz to 400 kHz. I²C H-level range = 1.3 V to 3.6 V. Please refer to the I²C specification from NXP for details.

Write protocol → write command to VEML6035

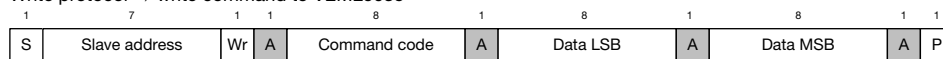

Read protocol → read data from VEML6035

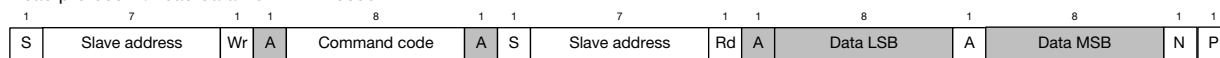

- S = start condition
- P = stop condition
- A = acknowledge
- N = no acknowledge
- Host action
- VEML6035 response

Fig. 11 - VEML6035 Command Protocol

Device Address

The VEML6035 has one fix slave address for the host programming and accessing selection. The predefined 7 bit I²C bus address is set to 0101001 = 0x29. The least significant bit (LSB) defines read or write mode. Accordingly the bus address is set to 0101 0010 = 52h for write and 0101 0011 = 53h for read.

Auto-Memorization

VEML6035 can memorize the last ambient data before shutdown and keep this data before waking up. When VEML6035 is in shutdown mode, the host can freely read this data via read command directly. When VEML6035 wakes up, the data will be refreshed by new detection.

**Command Register Format**

There are 6 command codes provided by VEML6035. Formats of these command code and registers' definition explanations are shown in below table.

COMMAND REGISTER FORMAT				
COMMAND CODE	REGISTER NAME	BIT	FUNCTION / DESCRIPTION	R / W
00	ALS_CONF 0	15 : 0	ALS gain, integration time, interrupt, and shut down	W
01	WH	15 : 8	High threshold window setting (MSB)	W
	WH	7 : 0	High threshold window setting (LSB)	W
02	WL	15 : 8	Low threshold window setting (MSB)	W
	WL	7 : 0	Low threshold window setting (LSB)	W
03	Reserved	15 : 0	Reserved	W
04	ALS	15 : 8	MSB 8 bits data of whole ALS 16 bits	R
	ALS	7 : 0	LSB 8 bits data of whole ALS 16 bits	R
05	WHITE	15 : 8	MSB 8 bits data of whole WHITE 16 bits	R
	WHITE	7 : 0	LSB 8 bits data of whole WHITE 16 bits	R
06	IF_L	15	Crossing low threshold INT trigger event	R
	IF_H	14	Crossing high threshold INT trigger event	R
	Reserved	13 : 0	Reserved	R

TABLE 1 - CONFIGURATION REGISTER 00 (HEX)		
REGISTER NAME	BIT	FUNCTION / DESCRIPTION
Reserved	15 : 13	Reserved
SENS	12	0 = high sensitivity, 1 = low sensitivity (1/8)
DG	11	0 = normal, 1 = double
GAIN	10	0 = normal sensitivity, 1 = double sensitivity
ALS_IT ⁽¹⁾	9 : 6	ALS integration time setting which represents how long ALS can update the readout value. 1100 = 25 ms 1000 = 50 ms 0000 = 100 ms 0001 = 200 ms 0010 = 400 ms 0011 = 800 ms
ALS_PERS	5 : 4	ALS interrupt persistence setting. The interrupt pin is triggered while sensor reading is out of threshold windows after consecutive number of measurement cycle 00 = 1 01 = 2 10 = 4 11 = 8
INT_CHANNEL	3	Selection for which channel the interrupt should trigger 0 = ALS CH interrupt 1 = WHITE CH interrupt
CHANNEL_EN	2	Channel enable function 0 = ALS CH enable only 1 = ALS and WHITE CH enable
INT_EN	1	Interrupt enable setting 0 = INT disable 1 = INT enable
SD	0	Shut down setting 0 = power on 1 = shutdown

Note

⁽¹⁾ Integration times have a tolerance of $\pm 30\%$

**TABLE 2 - HIGH THRESHOLD WINDOWS SETTING 01 (HEX)**

REGISTER NAME	BIT	FUNCTION / DESCRIPTION
01	15 : 8	High threshold window setting (MSB)
	7 : 0	High threshold window setting (LSB)

Note

- INT function must be enabled to trigger on this high threshold

TABLE 3 - LOW THRESHOLD WINDOWS SETTING 02 (HEX)

REGISTER NAME	BIT	FUNCTION / DESCRIPTION
02	15 : 8	Low threshold window setting (MSB)
	7 : 0	Low threshold window setting (LSB)

Note

- INT function must be enabled to trigger on this low threshold

TABLE 4 - ALS HIGH RESOLUTION OUTPUT DATA 04 (HEX)

REGISTER NAME	BIT	FUNCTION / DESCRIPTION
04	15 : 8	MSB 8 bits data of whole 16 bits
	7 : 0	LSB 8 bits data of whole 16 bits

TABLE 5 - WHITE CHANNEL OUTPUT DATA 05 (HEX)

REGISTER NAME	BIT	FUNCTION / DESCRIPTION
05	15 : 8	MSB 8 bits data of whole 16 bits
	7 : 0	LSB 8 bits data of whole 16 bits

TABLE 6 - INTERRUPT STATUS 06 (HEX)

REGISTER NAME	BIT	FUNCTION / DESCRIPTION
06	15	Low threshold interrupt flag 0 = interrupt not triggered 1 = interrupt occurred
	14	High threshold interrupt flag 0 = interrupt not triggered 1 = interrupt occurred

CALCULATING THE LUX LEVEL

Command code 04 contains the results of the ALS measurement. This 16-bit code needs to be converted to a decimal value to determine the corresponding lux value. The calculation of the corresponding lux level is dependent on the programmed gain setting and the chosen integration time.

The component is most sensitive with GAIN = 1, DG = 1, SENS = 0 and an integration time of 800 ms, specified to 0.0004 lx/step. Every time the integration time is halved, the resolution is halved, the lx/cnt value is doubled.

The same principle is valid for the gain and sensitivity settings. For GAIN = 0 it is doubled and also for DG = 1 it is again doubled. For SENS = 1 the sensitivity is programmed to just 1/8, to allow for higher illuminations up to about 6.7 klx.



The tables below shows these dependencies:

RESOLUTION AND MAXIMUM DETECTION RANGE AT DG = 1									
	GAIN = 1, SENS = 0	GAIN = 0, SENS = 0	GAIN = 1, SENS = 1	GAIN = 0, SENS = 1		GAIN = 1, SENS = 0	GAIN = 0, SENS = 0	GAIN = 1, SENS = 1	GAIN = 0, SENS = 1
IT (ms)	TYPICAL RESOLUTION (lx/cnt)					MAXIMUM POSSIBLE ILLUMINATION (lx)			
800	0.0004	0.0008	0.0032	0.0064		26	52	210	419
400	0.0008	0.0016	0.0064	0.0128		52	105	419	839
200	0.0016	0.0032	0.0128	0.0256		105	210	839	1678
100	0.0032	0.0064	0.0256	0.0512		210	419	1678	3355
50	0.0064	0.0128	0.0512	0.1024		(-) ⁽¹⁾	(-) ⁽¹⁾	(-) ⁽¹⁾	(-) ⁽¹⁾
25	0.0128	0.0256	0.1024	0.2048		(-) ⁽¹⁾	(-) ⁽¹⁾	(-) ⁽¹⁾	(-) ⁽¹⁾

RESOLUTION AND MAXIMUM DETECTION RANGE AT DG = 0									
	GAIN = 1, SENS = 0	GAIN = 0, SENS = 0	GAIN = 1, SENS = 1	GAIN = 0, SENS = 1		GAIN = 1, SENS = 0	GAIN = 0, SENS = 0	GAIN = 1, SENS = 1	GAIN = 0, SENS = 1
IT (ms)	TYPICAL RESOLUTION (lx/cnt)					MAXIMUM POSSIBLE ILLUMINATION (lx)			
800	0.0008	0.0016	0.0064	0.0128		52	105	419	839
400	0.0016	0.0032	0.0128	0.0256		105	210	839	1678
200	0.0032	0.0064	0.0256	0.0512		210	419	1678	3355
100	0.0064	0.0128	0.0512	0.1024		419	839	3355	6711
50	0.0128	0.0256	0.1024	0.2048		(-) ⁽¹⁾	(-) ⁽¹⁾	(-) ⁽¹⁾	(-) ⁽¹⁾
25	0.0256	0.0512	0.2048	0.4096		(-) ⁽¹⁾	(-) ⁽¹⁾	(-) ⁽¹⁾	(-) ⁽¹⁾

Note

(1) For integration times lower than 100 ms, the maximum count level is no longer 16 bit so half the integration time no longer leads to double the max. lux level

Example:

If the 16-bit word of the ALS data shows: 0000 0101 1100 1000 = 1480 (dec.), the programmed GAIN = 1, DG = 1, SENS = 1 and the integration time is 100 ms, the corresponding lux level is: light level [lx] = 1480 x 0.0256 = 37.888 lx.

PACKAGE DIMENSIONS in millimeters

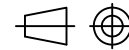
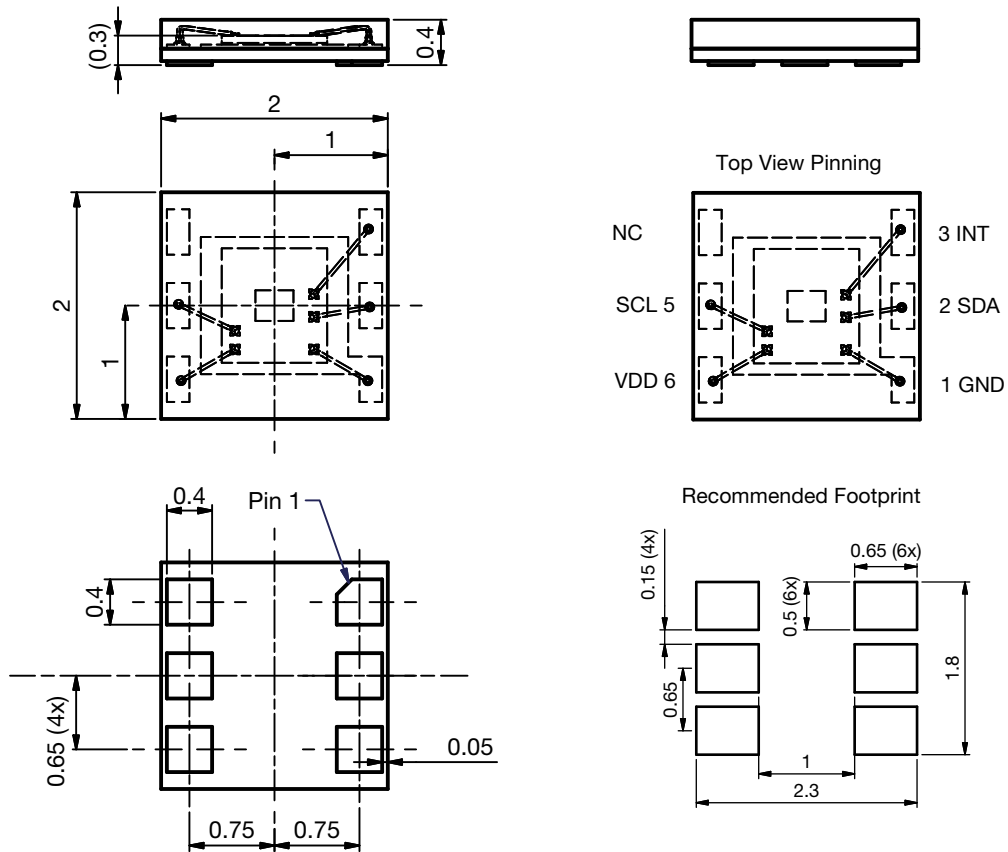

Technical drawings according to DIN specification

Drawing No.: 6.550-5359.01-4
Issue: preliminary 1; 13.02.2019

Not indicated tolerances ± 0.1

TAPE AND REEL DIMENSIONS in millimeters

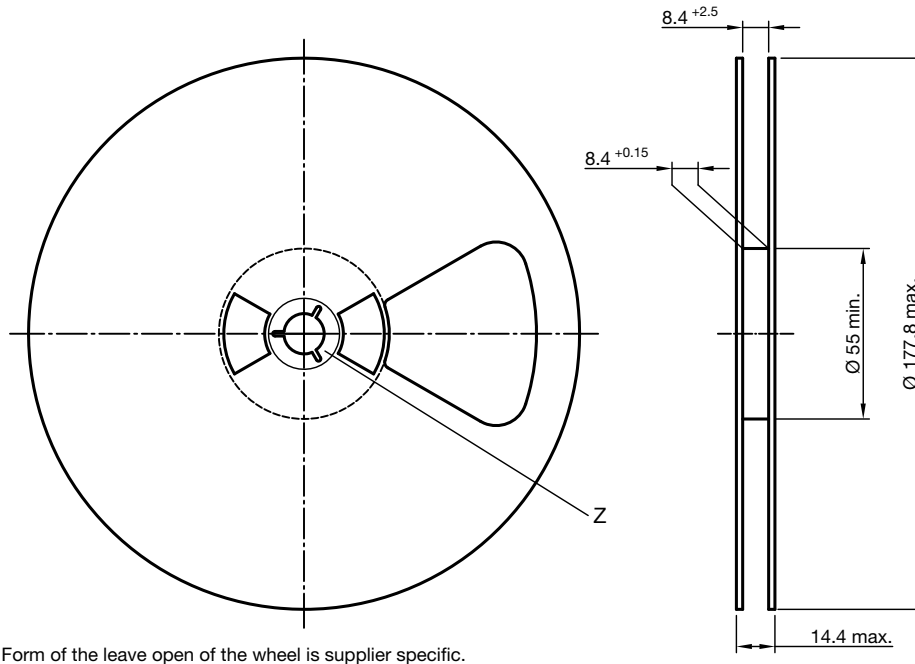

Form of the leave open of the wheel is supplier specific.

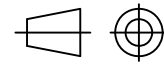
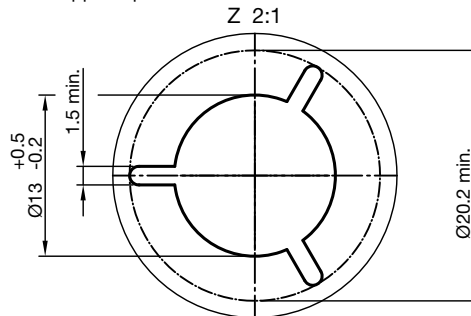

Technical drawings according to DIN specification.

Drawing-No.: 9.800-5096.01-4
Issue: 5; 20.12.2016

Fig. 12 - 7" Reel, 3000 Pieces

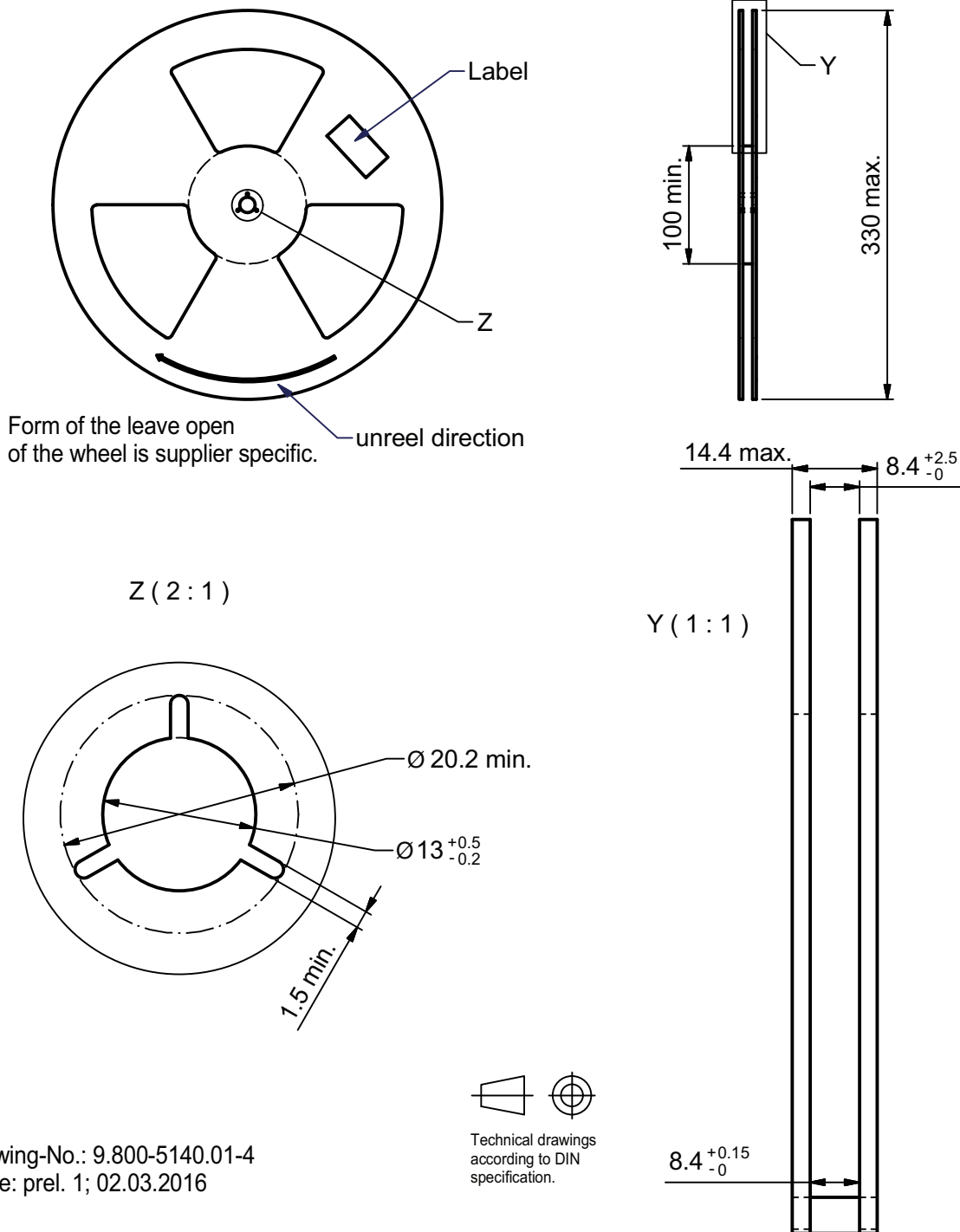

Drawing-No.: 9.800-5140.01-4
Issue: prel. 1; 02.03.2016

Fig. 13 - 13" Reel, 10 000 Pieces

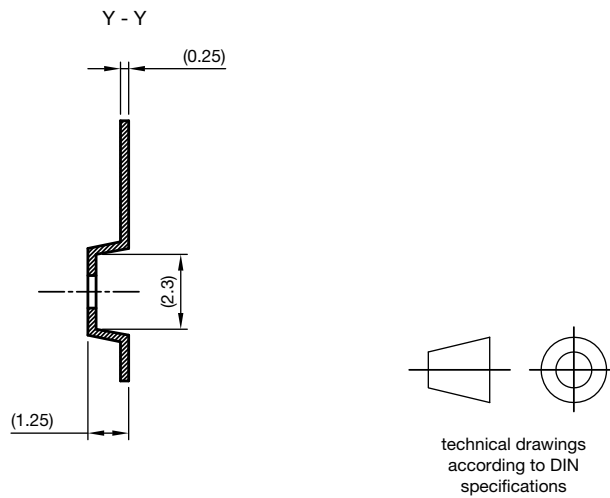
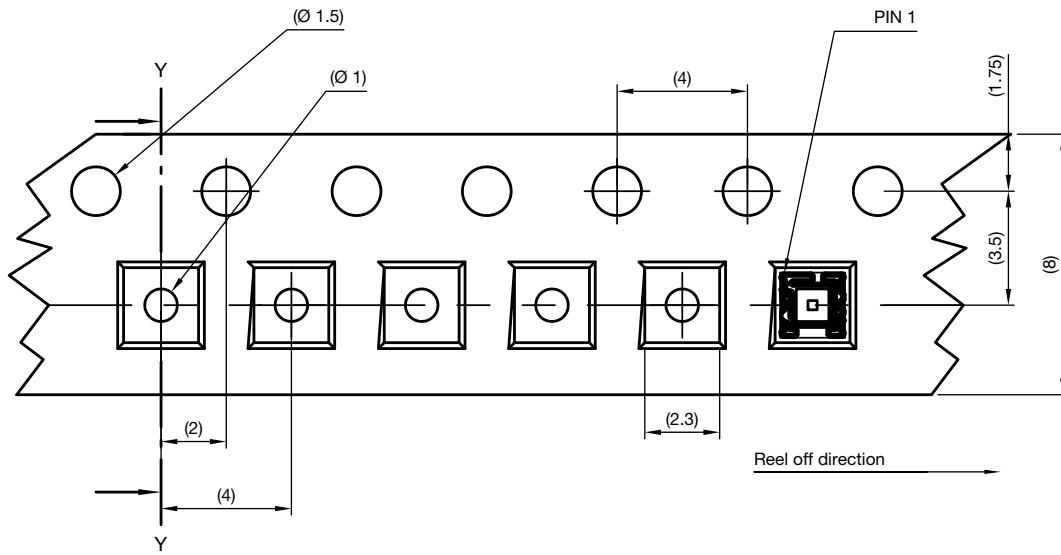

Drawing-No.: 9.700-5397.01-4
Issue: 1; 19.02.16

Fig. 14 - Taping

RECOMMENDED STORAGE AND REBAKING CONDITIONS				
PARAMETER	CONDITIONS	MIN.	MAX.	UNIT
Storage temperature		5	50	°C
Relative humidity		-	60	%
Open time		-	72	h
Total time	From the date code on the aluminized envelope (unopened)	-	6	months
Rebaking	Tape and reel: 60 °C	-	22	h
	Tube: 60 °C	-	22	h

RECOMMENDED INFRARED REFLOW

Soldering conditions which are based on J-STD-020 C

IR REFLOW PROFILE CONDITION			
PARAMETER	CONDITIONS	TEMPERATURE	TIME
Peak temperature		255 °C + 0 °C / - 5 °C (max.: 260 °C)	10 s
Preheat temperature range and timing		150 °C to 200 °C	60 s to 180 s
Timing within 5 °C to peak temperature		-	10 s to 30 s
Timing maintained above temperature / time		217 °C	60 s to 150 s
Timing from 25 °C to peak temperature		-	8 min (max.)
Ramp-up rate		3 °C/s (max.)	-
Ramp-down rate		6 °C/s (max.)	-

Recommend Normal Solder Reflow is 235 °C to 255 °C

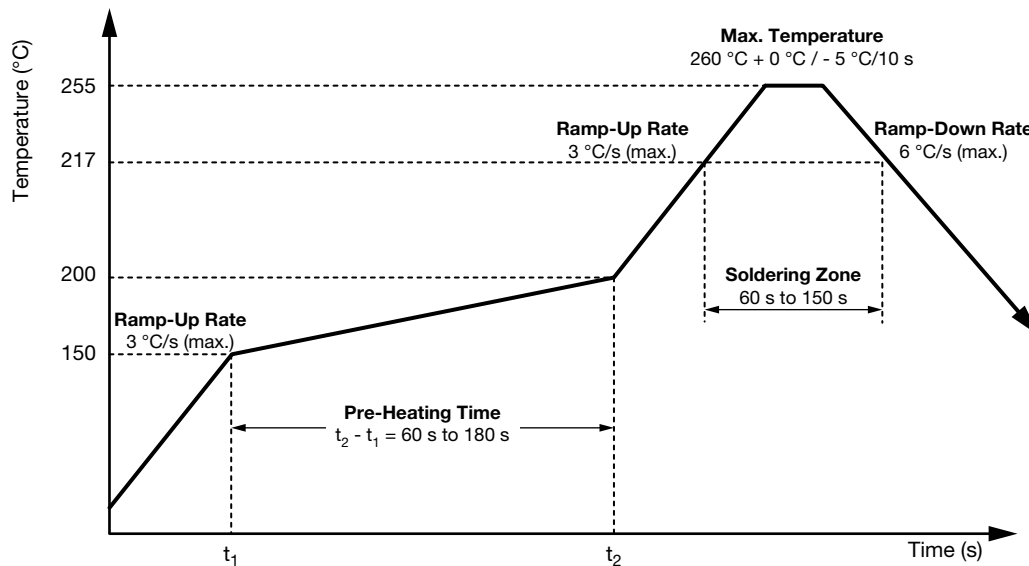

Fig. 15 - VEML6035 Solder Reflow Profile Chart

DRYPACK

Devices are packed in moisture barrier bags (MBB) to prevent the products from moisture absorption during transportation and storage. Each bag contains a desiccant.

FLOOR LIFE

Floor life (time between soldering and removing from MBB) must not exceed the time indicated on MBB label:

Floor life: 168 h

 Conditions: $T_{amb} < 30\text{ °C}$, $RH < 60\%$

Moisture sensitivity level 3, according to J-STD-020.

DRYING

In case of moisture absorption devices should be baked before soldering. Conditions see J-STD-020 or label. Devices taped on reel dry using recommended conditions 192 h at 40 °C (+ 5 °C), $RH < 5\%$.



Disclaimer

ALL PRODUCT, PRODUCT SPECIFICATIONS AND DATA ARE SUBJECT TO CHANGE WITHOUT NOTICE TO IMPROVE RELIABILITY, FUNCTION OR DESIGN OR OTHERWISE.

Vishay Intertechnology, Inc., its affiliates, agents, and employees, and all persons acting on its or their behalf (collectively, "Vishay"), disclaim any and all liability for any errors, inaccuracies or incompleteness contained in any datasheet or in any other disclosure relating to any product.

Vishay makes no warranty, representation or guarantee regarding the suitability of the products for any particular purpose or the continuing production of any product. To the maximum extent permitted by applicable law, Vishay disclaims (i) any and all liability arising out of the application or use of any product, (ii) any and all liability, including without limitation special, consequential or incidental damages, and (iii) any and all implied warranties, including warranties of fitness for particular purpose, non-infringement and merchantability.

Statements regarding the suitability of products for certain types of applications are based on Vishay's knowledge of typical requirements that are often placed on Vishay products in generic applications. Such statements are not binding statements about the suitability of products for a particular application. It is the customer's responsibility to validate that a particular product with the properties described in the product specification is suitable for use in a particular application. Parameters provided in datasheets and / or specifications may vary in different applications and performance may vary over time. All operating parameters, including typical parameters, must be validated for each customer application by the customer's technical experts. Product specifications do not expand or otherwise modify Vishay's terms and conditions of purchase, including but not limited to the warranty expressed therein.

Except as expressly indicated in writing, Vishay products are not designed for use in medical, life-saving, or life-sustaining applications or for any other application in which the failure of the Vishay product could result in personal injury or death. Customers using or selling Vishay products not expressly indicated for use in such applications do so at their own risk. Please contact authorized Vishay personnel to obtain written terms and conditions regarding products designed for such applications.

No license, express or implied, by estoppel or otherwise, to any intellectual property rights is granted by this document or by any conduct of Vishay. Product names and markings noted herein may be trademarks of their respective owners.

Данный компонент на территории Российской Федерации

Вы можете приобрести в компании MosChip.

Для оперативного оформления запроса Вам необходимо перейти по данной ссылке:

<http://moschip.ru/get-element>

Вы можете разместить у нас заказ для любого Вашего проекта, будь то серийное производство или разработка единичного прибора.

В нашем ассортименте представлены ведущие мировые производители активных и пассивных электронных компонентов.

Нашей специализацией является поставка электронной компонентной базы двойного назначения, продукции таких производителей как XILINX, Intel (ex.ALTERA), Vicor, Microchip, Texas Instruments, Analog Devices, Mini-Circuits, Amphenol, Glenair.

Сотрудничество с глобальными дистрибьюторами электронных компонентов, предоставляет возможность заказывать и получать с международных складов практически любой перечень компонентов в оптимальные для Вас сроки.

На всех этапах разработки и производства наши партнеры могут получить квалифицированную поддержку опытных инженеров.

Система менеджмента качества компании отвечает требованиям в соответствии с ГОСТ Р ИСО 9001, ГОСТ РВ 0015-002 и ЭС РД 009

Офис по работе с юридическими лицами:

105318, г.Москва, ул.Щербаковская д.3, офис 1107, 1118, ДЦ «Щербаковский»

Телефон: +7 495 668-12-70 (многоканальный)

Факс: +7 495 668-12-70 (доб.304)

E-mail: info@moschip.ru

Skype отдела продаж:

moschip.ru

moschip.ru_4

moschip.ru_6

moschip.ru_9